

Mechanical stress relaxation in hetero-modulus, hetero-viscous complex ceramic materials

LÁSZLÓ A. GÖMZE ■ Department of Ceramics and Silicate Engineering, University of Miskolc
 ■ femgomze@uni-miskolc.hu

LUDMILA N. GÖMZE ■ IGREX Engineering Service Ltd. ■ igrex@freemail.hu

Received: 22.11.2010. ■ Érkezett: 2010.11.22.

Hetero-modulus, hetero-viscous complex materials have several advantages in accordance to mechanical and thermal properties comparing with the traditional ceramics and ceramic matrix composites. In this paper the authors examined in details the high speed collision processes between flying metallic objects and ceramics, such as α -Si₃N₄, β -Si₃N₄, Si₂ON₂, SiAlON, AlN and 3Al₂O₃SiO₂ reinforced alumina matrix hybrid materials, as well as their rheo-mechanical structures and properties. Understanding the high speed collision process, material structures, rheological properties of such a complex hybrid material, the authors in this paper mathematically describe the mechanical shear stress and its relaxation during and after high speed collisions in α -Si₃N₄, β -Si₃N₄, Si₂ON₂, SiAlON, AlN and 3Al₂O₃SiO₂ reinforced alumina matrix composites. The dynamic strength of the developed and examined corundum matrix complex materials was tested through collision with high density metallic flying bodies, with speed higher than 900 m/sec and described in works [27, 29, 42]. Analytical methods applied in this research were scanning electron microscopy, X-ray diffraction and energy dispersive spectrometry. Digital image analysis was applied to microscopy results, to enhance the results of transformation.

Keywords: ceramics, CMC, elasticity, hybrid materials, plasticity, stress relaxation, viscosity

1. Introduction

In the last 15–20 years scientists, engineers and experts working in laboratories of universities and research institutes or in ceramic manufactory plants have been engaged in development of more efficient ceramic materials and items for different industrial purposes [1–4]. The sophisticated industry and technology [5–7] require higher and higher assumption against to mechanical properties, such as hardness [8–13], strength [14–20], wear resistance [21–24], toughness [25, 26] and dynamic strength [27–29]. Till today several types of ceramic materials and ceramic matrix composites (CMC) are develop with excellent mechanical properties, with high values of mechanical strength and hardness, but most of these materials have microstructures with relatively large crystals, having high rigidness and strong inclination to nick, pitting and rigid fractures. Generally materials with these kind of crystal structures do not have required dynamic strength, and they are not suitable for collisions with other materials and bodies under high speeds. Because of this substantial research has been done in ceramic industry to reduce grain size [30–34] aiming to increase the above favourable mechanical properties. However to increase mechanical properties the authors often use a simultaneous pressure during sintering applying hot isostatic pressing sintering [20, 33, 35] or spark plasma sintering [36, 37], as presence of pore in the ceramic structure results a significant decrease in its mechanical strength. To obtain high density alumina-zirconia ceramics Wang, Huang and Wu [38] used two-step sintering process, and by Hernández, Torre and R. Rangel [39] Al₂O₃ matrix cermets were produced from mechanically mixed powders containing Al, Fe and Ti metals as reinforcements.

László A. GÖMZE

is head of Department of Ceramics and Silicate Engineering in the University of Miskolc since 1999. He has got scientific degree „Candidate of Technical and Engineering Sciences” at Moscow University M. I. S. I. in 1985, and has a wide range of experiments both in engineering and research works at different companies and in teaching of students at universities. Finishing the Civil Engineering University of Moscow (Russia) in 1973, L. A. Gómze started his working activity as structural engineering at the design department in Hungarian firm Building Ceramics (Épületkerámia) in Budapest. In 1986 he was already the managing director of the famous Hungarian porcelain manufactory HOLLÓHÁZA. Leaving Hollóháza in 1990 he used to work as associated professor at University of Miskolc. Laszlo A. Gómze is member of several Hungarian and international organization in fields of ceramics, material sciences and chemistry. He is member of „Kerpely Antal Doctoral School” of material sciences and technologies. Since 1996 he has successfully supervised several PhD students in fields of ceramics and ceramic matrix composites.

Ludmila N. GÖMZE

is the managing director of engineering service firm IGREX Ltd. Finishing the Civil Engineering University of Moscow (Russia) in 1974 she started her working activity as structural engineer at Hungarian design institution VIZITERV in Budapest. Further she continued her job as designer engineer at firm KEVITERV in city Miskolc. In her working experiments she met with the problems of productions and technologies of ceramic items at the porcelain manufactory HOLLÓHÁZA in 1987. Since then she has a wide range experiments in examination, research and development of new material compositions and technologies both of traditional and high-tech structural ceramics as well as of ceramic matrix composites. The research works of Ludmilla N. Gómze are presented in several research reports, conference publications and 5 scientific articles in different German and Hungarian journals.

Examining the material structure and excellent mechanical properties of SiAlON ceramic composites the advantages of hetero-modulus materials first was described by German scientist Dr. Hasselman and his co-authors [40] in early of 1980's. The values of Young's modulus and melting temperatures of advance materials, metal alloys and ceramics (Fig. 1.) was introduced by Igor Shabalin [41] as CE6 Session chair in Symposium ceramics and Engineering of XIVth International Clay Conference (14 ICC).

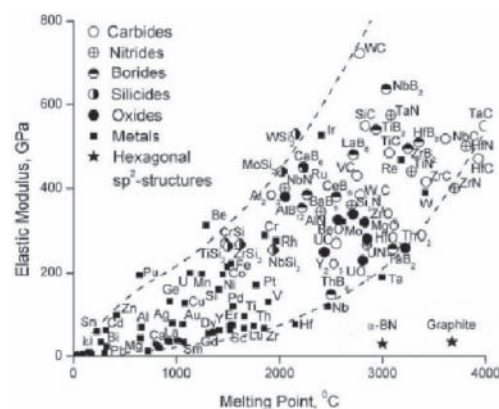

Fig. 1. Melting points and elastic modulus of advanced technical materials (Taken from Igor Shabalin, 14-icc, Session CE6)

1. ábra Korszerű műszaki anyagok olvadáspontja és rugalmassági modulusa

From Fig.1. it is obvious that most of ceramics, borides, nitrides and carbides have both high values of Young's elastic modulus and melting points. Constructing a new material structure from particles – components – having different Young's modulus and melting temperatures a new hybrid material could be create with the following valuable advantages:

- high damage tolerance,
- ability to absorb and dissipate the elastic energy during crack propagation,
- good thermal shock resistance.

Understanding the advantages of hetero-modulus materials new corundum matrix ceramic composites reinforced with Si_3N_4 , $\beta\text{-Si}_3\text{N}_4$, Si_2ON_2 , SiAlON , AlN and $3\text{Al}_2\text{O}_3\text{SiO}_2$ particles were successfully developed by the authors [27, 29, 42]. In this work our aims are the following:

- understand the mechanical behaviour and properties of hetero-modulus, hetero-viscous complex materials and create their rheo-mechanical model,
- describe mathematically the mechanical stress development and relaxation during and after high speed collision in this kind of complex materials.

2. Materials and experimental procedures

The high speed collision process and energy engorgement through fractures of traditional and hetero-modulus ceramics were already described in details by authors in works [27, 32, 42]. The thermic part of collision energy also was described in the above works and in [29], but there is no works in accordance to high speed collision behaviour of hetero-modulus and hetero-viscous complex and hybrid materials in spite of their following advantages are obvious:

- high damage tolerance,
- higher deformation tolerance,
- ability to absorb and dissipate the collision energy,
- relax by time mechanical stress developed in body during high speed collisions.

The mechanical model of complex material structures completed from particles having different values of elastic modulus and viscosity could be modelled by Fig. 2.

To achieve this kind of mechanical model with several Young's modulus, plasticity and viscosity, our high purity Al_2O_3 powder was polluted and mixed with submicron particles of SiO_2 , Si_3N_4 , SiAlON , AlN , Ti_2O_3 and other oxides and elements. This new material composition was milled in planetary-ball mill through several hours, and finally a powder mix containing 92 m% of Al_2O_3 was got. This powder mix were compacted uni-axially, using high speed flying punches with high kinetic energy by principle as shown in Fig. 3.

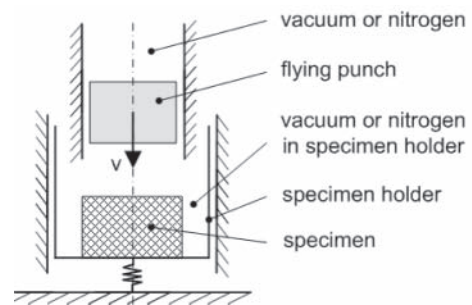

Fig. 3. Principle of compacting specimens under high speed flying punches with high kinetic energy

3. ábra A nagy kinetikai energiájú sajtolás elve nagy sebességű repülő prés-szerszámmal

There are several methods are used to develop SiAlON particles and transform $\alpha\text{-Si}_3\text{N}_4$ into $\beta\text{-Si}_3\text{N}_4$, but all of them used sintering temperatures much about 1700 °C or hot pressing at 1800 °C under pressure of 23 MPa or more [43–47]. In our case we used multi-steps sintering technology processes in which the compacted specimens first were pre-sintered in nitrogen (N_2) atmosphere under special firing curves. Due to phase transformation and recrystallization occurred during the following steps of sintering a new hetero-modulus and hetero-viscous corundum matrix composite (CMC) was developed reinforced with micron and submicron whiskers, nano-particles and viscous glass-like phases as it is shown in Fig. 4.

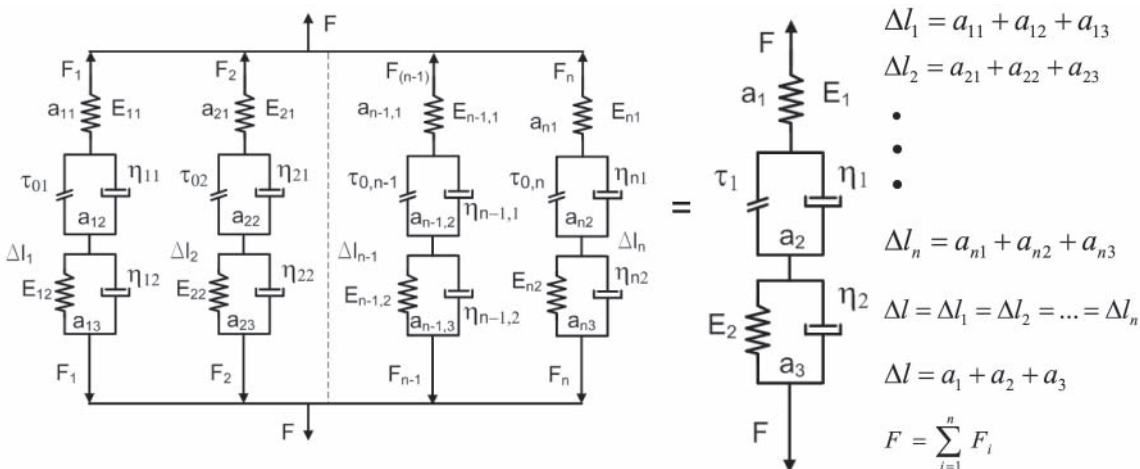

Fig. 2. Mechanical model of hetero-modulus, hetero-viscous complex materials

$a_{11} \dots a_{n1}$ – deformations of elastic particles; $a_{12} \dots a_{n2}$ – deformation of viscous-plastic particles; $a_{13} \dots a_{n3}$ – deformation of viscous-elastic particles; $E_{11} \dots E_{n1}$ – Young's modulus of Hooke particles; $E_{12} \dots E_{n2}$ – Young's modulus of viscous-elastic particles; $F_1 \dots F_n$ – forces on material particles; $\eta_{11} \dots \eta_{n1}$ – viscosity of viscous-plastic particles; $\eta_{12} \dots \eta_{n2}$ – viscosity of viscous-elastic particles; $\tau_{01} \dots \tau_{0n}$ – static yield stress in viscous-plastic particles; $\Delta l_1 \dots \Delta l_n$ – total deformation of particles

2. ábra A hetero-modulusú és hetero-viszkozitású komplex anyagok mechanikai anyagmodellje

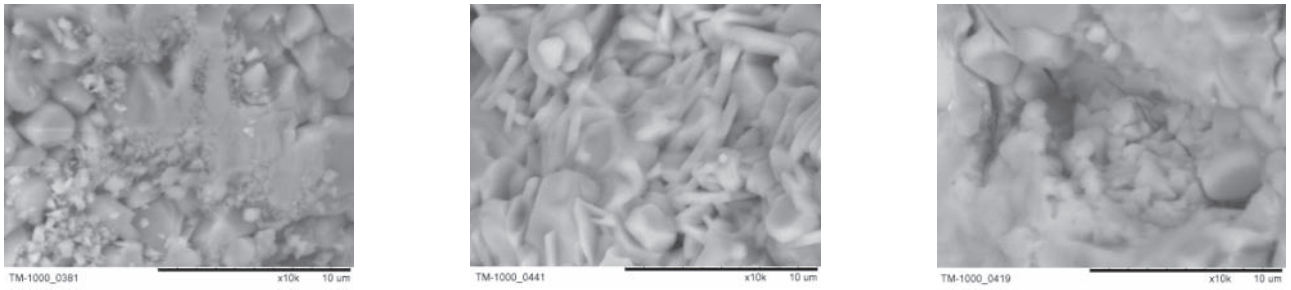

Fig. 4. Achieved microstructures after sintering
4. ábra A szinterelés során előállított hibridanyagok mikroszerkezete

3. Results and discussion

The shear stresses developing during high speed collisions in the above introduced (Fig. 4.) hetero-modulus and hetero-viscous hybrid materials could be described by Eq. 1.

$$\tau_0 - \tau \left[\frac{\eta_1}{\eta_e} + 1 + n_\tau - n_\gamma \left(1 + \frac{\eta_1}{\eta_2} \right) \right] + \frac{\eta_1 n_\gamma}{\eta_e} \dot{\tau} - n_\tau n_\gamma \ddot{\tau} = 0 \quad (1)$$

where:

- η_1, η_2 and η_e : viscosities of elastic-viscous-plastic, elastic-viscous parts and effective viscosity of the hybrid hetero-modulus and hetero-viscous body,
- τ_0 and τ : static yield point of body and shear stress developed during deformation and destruction in the material,
- n_τ and n_γ : stress relaxation time and delay time of elastic deformation,
- $\dot{\tau}$ and $\ddot{\tau}$: first and second derivatives of shear stresses developed in hetero-modulus and hetero-viscous ceramic and CMC bodies during high speed collision with flying objects.

The effective viscosity of the hetero-modulus and hetero-viscous complex materials could be determined by Eq. 2. as the following:

$$\eta_e = \frac{\tau_0 + \eta_1 \dot{\gamma} + \eta_1 n_\gamma \ddot{\gamma}}{\dot{\gamma} + n_\tau + n_\gamma \ddot{\gamma} + \dot{\gamma} \left[n_\tau - n_\gamma \left(1 + \frac{\eta_1}{\eta_2} \right) \right]} \quad (2)$$

where:

- $\dot{\gamma}, \ddot{\gamma}$ and $\ddot{\gamma}$: the first, second and third derivatives of deformation-speed gradients.

Involving the following new symbols:

$$A = -n_\tau n_\gamma, \quad (3.1)$$

$$B = \frac{\eta_1 n_\gamma}{\eta_e}, \quad (3.2)$$

$$C = - \left[\frac{\eta_1}{\eta_2} + 1 + n_\tau - n_\gamma \left(1 + \frac{\eta_1}{\eta_2} \right) \right], \quad (3.3)$$

$$D = \tau_0, \quad (3.4)$$

$$x = \tau, \quad (3.5)$$

the Eq. 1. could be rewrite to the following well known form:

$$A\ddot{x} + B\dot{x} + Cx + D = 0. \quad (4)$$

During the high speed collision ($u \geq 1000$ m/s) there is no plastic deformation in materials, so $D=0$ and Eq. 4 could be rewrite as:

$$A\ddot{x} + B\dot{x} + Cx = 0 \quad (5)$$

The Eq. 5. is well-known as the mathematical equation of damped harmonic oscillation, the solutions of which are the followings:

$$\bar{x} = C_1 e^{\lambda_1 t} + C_2 e^{\lambda_2 t} \quad (6.1)$$

$$\lambda_{1,2} = -\frac{B}{2A} \pm \sqrt{\frac{B^2}{4A^2} - \frac{C}{A}} \quad (6.2)$$

$$X^* = -\frac{D}{C}, \quad (6.3)$$

where :

- C_1 and C_2 are the constants of integration.

Substitute the above expressions the general equation of shear stress relaxation in hybrid hetero-modulus and hetero-viscous ceramics and CMC after high speed collision could be described as:

$$\tau = C_1 e^{\left(-\frac{B}{2A} + \sqrt{\frac{B^2}{4A^2} - \frac{C}{A}} \right) t} + C_2 e^{\left(-\frac{B}{2A} - \sqrt{\frac{B^2}{4A^2} - \frac{C}{A}} \right) t} - \frac{D}{C} \quad (7)$$

Substitute the A, B, C and D with the original material constants the value of the mechanical shear stress developed in hetero-viscous and hetero-modulus particles reinforced corundum matrix composite material during high speed collision and its relaxation mathematically could be described as the following:

$$\tau = C_1 e^{\left(-\frac{\eta_1}{2\eta_e n_\tau} + \sqrt{\frac{\eta_1^0}{4\eta_e^2 n_\tau^2} - \frac{\frac{\eta_1}{\eta_2} + 1 + n_\tau - n_\gamma \left(1 + \frac{\eta_1}{\eta_2} \right)}{n_\tau n_\gamma}} \right) t} + C_2 e^{\left(-\frac{\eta_1}{2\eta_e n_\tau} - \sqrt{\frac{\eta_1^0}{4\eta_e^2 n_\tau^2} - \frac{\frac{\eta_1}{\eta_2} + 1 + n_\tau - n_\gamma \left(1 + \frac{\eta_1}{\eta_2} \right)}{n_\tau n_\gamma}} \right) t} + \frac{\tau_0}{\frac{\eta_1}{\eta_2} + 1 + n_\tau - n_\gamma \left(1 + \frac{\eta_1}{\eta_2} \right)} \quad (8)$$

4. Conclusion

Understanding the high damage and deformation tolerance and ability to observe and dissipate the collision energy of hetero-modulus and hetero-viscous submicron and nano-

particle reinforced corundum matrix hybrid ceramics and CMCs, the authors successfully created a rheo-mechanical model (Fig. 2.) and mathematical equation (Eq. 8.) to mechanically characterize such a complex material structures of ceramics and composites.

This kind of mechanical model and mathematical equation can help in development high damage and deformation tolerance complex materials like α - Si_3N_4 , β - Si_3N_4 , Si_2ON_2 , SiAlON , AlN , $3\text{Al}_2\text{O}_3\cdot 2\text{SiO}_2$ submicron and nano-particle and liquid phase particle (glass) reinforced alumina matrix hybrid materials.

Acknowledgement

The authors acknowledge to Igrey Ltd. for the technical support of our research for several years and to young teaching staff and PhD students of Department of Ceramic and Silicate Engineering at the University of Miskolc (Hungary) for laboratory tests and assistance.

References

- S. Matsumoto – N. Miyoshi – T. Kanazawa – M. Kimura – M. Ozawa – S. Yoshida – N. Tabezawa – T. Ono: (Eds.) *Catalysis science and technology* 1, 335 (1991)
- Morikawa – T. Suzuki – K. Kikuta – A. Suda – H. Shinjo: *Epitoanyag*, Vol. 61, pp. 2. (2009)
- E. S. Lukin – N. A. Makarov – A. I. Kozlov – N. A. Popova – E. V. Anufrieva – M. A. Vartanyan – I. U. A. Kozlov – M. N. Safina – D. O. Lemeshev: *Steklo i Keramika*, No. 10, pp. 27 (2008)
- C. B. Carter – M. G. Norton: *Ceramic materials, science and Engineering* (2007)
- K. Katahira – Y. Watanabe – H. Ohmori – T. Kato: *Int. Journal of Machine Tools & Manufacture*, Vol. 42, pp. 1307 (2002)
- L. Shabalin – V. M. Vishnyakov – D. J. Bull – S. G. Keens – L. F. Yamshchikov – L. I. Shabalin: *J. Alloys and Compounds*, Vol. 472, p. 373 (2009)
- E. Rocha-Rangel – D. Hernández-Silva – E. Terrés-Rojas – E. Martínez-Franco – S. Díaz-De La Torre: *Epitoanyag*, Vol. 62, pp. 75 (2010)
- S. D. Skrovaneck – R. C. Bradt: *J. Am. Ceram. Soc.*, Vol. 62 (3–4), pp. 215 (1979)
- N. I. Ershova – I. Yu. Kelina: *Epitoanyag*, Vol. 61, pp. 34 (2009)
- R. W. Rice – C. C. Wu – F. Borchelt: *J. Am. Ceram. Soc.*, Vol. 77 (10), pp. 2539 (1994)
- Krell – P. Blank: *J. Am. Ceram. Soc.*, Vol. 78 (4), pp. 1118 (1995)
- B. Venkataraman – G. Sundarajan: *Acta Materialica*, Vol. 44. No. 2. pp. 451. (1996)
- S. N. Kulkov – N. L. Savchenko: *Epitoanyag*, Vol. 61. No. 3. pp. 62. (2008)
- P. Chantikul – S. J. Bannison – B. R. Lawn: *J. Am. Ceram. Soc.*, Vol. 73 (8), pp. 2419 (1990)
- J. Seidel – N. Claussen – J. Rödel: *J. Eur. Ceram. Soc.*, Vol. 15, pp. 395 (1995)
- J. B. Wachtman: *Mechanical properties of ceramics*, Wiley-Interscience Publication (1996)
- R. W. Rice: *J. Mater. Sci.*, Vol. 32, pp. 1673 (1997)
- J. Csányi – L. A. Gömze: *Epitoanyag*, Vol. 53, pp. 66 (2001)
- A. G. Tkachev – O. N. Tkacheva: *Steklo i Keramika*, No. 2, p. 15. (2009)
- Y. T. O – J. B. Koo – K. J. Hong – J. S. Park – D. C. Shin: *Mater. Sci. Eng. A*, Vol. 374, pp. 191 (2004)
- T. Senda – E. Yasuda – M. Kaji – R. C. Bradt: *J. Am. Ceram. Soc.*, Vol. 82 (6), pp. 1505 (1999)
- R. S. Roy – H. Guchhait – A. Chanda – D. Basu – M. K. Mitra: *J. Eur. Ceram. Soc.*, Vol. 27, pp. 4737 (2007)
- S. N. Kulkov – N. I. Savchenko: *Epitoanyag*, Vol. 60, pp. 62 (2008)
- J. Csányi – L. A. Gömze: *Epitoanyag*, Vol. 60, pp. 2 (2008)
- Zer – R. Riedel – T. Sekine – J. E. Lowther – W. Y. Ching – I. Tanaka: *Advanced Materials (FRG)*, Vol. 18, pp. 2933 (2006)
- Muchtar – L. C. Lim: *Acta Mater.*, Vol. 46 (5), pp. 1683 (1998)
- L. A. Gömze – L. N. Gömze: *Epitoanyag*, Vol. 61, pp. 38 (2009)
- V. V. Yakushev – A. V. Utkin – A. N. Zhukov: *Proceedings of Int. Conf. XI Khariton's Readings, Extreme States of Substance*, pp. 204 (2009)
- L. A. Gömze – L. N. Gömze: *Proceedings of Int. Conf. XI Khariton's Readings, Extreme States of Substance*, pp. 324 (2009)
- M. C. Santos – A. R. A. Nogueira – J. A. Nogueira: *Journal of the Brazilian Chemical Society*, Vol. 16, pp. 108 (2005)
- F. Dellisanti – G. Valdre: *International Journal of Mineral Processing*, Vol. 88, pp. 94 (2008)
- L. A. Gömze: *Mat. Sci. Forum*, Vol. 659, pp. 19 (2010)
- R. Apetz – M. P. B. Bruggen: *J. Am. Ceram. Soc.*, Vol. 86, pp. 480 (2003)
- S. N. Kulkov – M. V. Grigoriev: *Epitoanyag*, Vol. 62, pp. 66 (2010)
- Krell – P. Blank – H. Ma – T. Hutzler – M. Nebelung: *Am. Ceram. Soc.*, Vol. 86 (4), pp. 546 (2003)
- Z. Shen – M. Johnson – Z. Zhao – M. Nygren: *J. Am. Ceram. Soc.*, Vol. 85, pp. 1921 (2002)
- B. N. Kim – K. Hiraga – K. Morita – H. Yoshida: *Scripta Mater.*, Vol. 57 (7), pp. 607 (2007)
- J. Wang – C. Y. Huang – Y. C. Wu: *Ceramics International*, Vol. 35, pp. 1467 (2009)
- J. G. Miranda-Hernández – E. Rocha-Rangel – S. Díaz De La Torre: *Epitoanyag* Vol. 62, pp. 2 (2010)
- D. P. H. Hasselman – P. F. Becher – K. S. Mazdiyasi: *Zeitschrift Werkstofftech*, Vol. 11, No. 3, pp. 82 (1980)
- I. Shabalin: *International Clay Conference*, Book of Abstracts Vol. 1. pp. 93. (2009)
- L. A. Gömze – L. N. Gömze: *Mat. Sci. Forum*, Vol. 659, pp. 165. (2010)
- S. Hampshire – H. K. Park – D. P. Thompson – K. H. Jack: *Nature Vol. 274*, pp. 880 (1978)
- G. G. Deeley – J. M. Herbert – N. C. Moore: *Powder Metallurgy* Vol. 8 pp. 145 (1961)
- F. L. Riley: *J. Am. Ceram. Soc.*, Vol. 83, pp. 245 (2000)
- Tsuge – K. Nishida: *Am. Ceram. Soc. Bull.*, Vol. 57, pp. 424 (1978)
- F. F. Laange: *J. Ceram. Soc. Japan*, Vol. 114, pp. 873 (2006)

Mechanikai feszültségek relaxációja a hetero-modulusú és hetero-viszkózusú komplex kerámiákban

Mechanikai és termikus tulajdonságukat tekintve a hetero-modulusú és hetero-viszkózusú komplex anyagok számos előnnyel rendelkeznek a hagyományos kerámiákkal és kerámia mátrixú kerámiákkal szemben. Jelen publikációban a szerzők részletesen vizsgálták a nagy sebességgel repülő fémek és kerámiatestek közötti ütközés folyamatát, különösen a α - Si_3N_4 , β - Si_3N_4 , Si_2ON_2 , SiAlON és $3\text{Al}_2\text{O}_3\cdot 2\text{SiO}_2$ szubmikron és nanoszemcsékkel erősített alumínium mátrixú hibrid anyagokra és azok reo-mechanikai szerkezetére és tulajdonságaira. Megértve a nagy sebességű ütközések folyamatát, valamint az ilyen hibrid anyagok anyagszerkezete és reológiai tulajdonságai közötti kapcsolatokat, jelen munkában a szerzők leírják az α - Si_3N_4 , β - Si_3N_4 , Si_2ON_2 , SiAlON és $3\text{Al}_2\text{O}_3\cdot 2\text{SiO}_2$ erősített alumínium-oxid mátrixú kerámia-kompozitokban nagy sebességű ütközések során ébredő mechanikai nyírófeszültségek egyenletét és azok ütközés utáni relaxációját. A vizsgált korund mátrixú komplex anyagok nagy sebességgel történő ütközését és annak energiaelnyerését a szerzők a [27, 29, 42] munkákban is már ismertették részletesen. Jelen vizsgálatok során a szerzők Scanning elektronmikroszkópot, röntgendiffrakciós készüléket és energiadiszperz spektrométert alkalmaztak. Az eredmények feldolgozásához és kiértékeléséhez a digitális képelemzés módszerét használták. Kulcsszavak: feszültség-relaxáció, hibrid anyagok, képlékenység, kerámiák, kompozitok, rugalmasság, viszkozitás

Ref.:

László A. Gömze – Ludmilla N. Gömze: *Mechanical stress relaxation in hetero-modulus, hetero-viscous complex ceramic materials.* Építőanyag, 62. évf. 4. szám (2010), 98–101. p.