

A Complex Comparatrive Study of Two Dissimilar Engine Valve Constructions, for the In-Cylinder Flow Behaviour of a High Speed, IC Engine

László Kovács, Betti Bolló, Szilárd Szabó

University of Miskolc, Institute of Energy Engineering and Chemical Machinery,
Miskolc-Egyetemváros, 3515 Miskolc, Hungary, aramkola@uni-miskolc.hu,
beti.bollo@uni-miskolc.hu, szilard.szabo@uni-miskolc.hu

Abstract: In our research we investigated the possibility of offering a viable alternative for internal combustion engines' poppet valves. After examining in-cylinder flow characterization methods, we derived a computer model of the base concept and a special swinging valve arrangement. The flow characterization of both arrangements has been completed using numerical fluid dynamics software. To minimize numerical errors different mesh scenarios were investigated and evaluated. From our research activity a clear picture has been drawn on the qualities of the proposed system. The swinging valve arrangement improves the efficiency of the gas exchange process. Also, the flow during the intake process is more structured and has less local vorticity. The results have also shown a very favourable charge movement pattern that is ideal for GDI engines. All of these findings produce an appropriate platform for a stratified charging, extra lean burning engine concept. The construction concept lends itself to be flawlessly integrated in a throttle-less engine control environment as well. With these qualities the new valve arrangement may be the ideal solution to produce fuel efficient, high specific output engines, for those transportation systems that will still need to rely on fossil fuels in the future.

Keywords: IC engine; swinging valve; poppet valve; flow test; 0D/1D engine simulation

1 Introduction

In the case of gasoline, diesel or gas-powered internal combustion engines currently in series production, almost without exception, a straight-line valve located in the cylinder head is used. In valve timing systems with alternating movement, it is a difficult task to reduce the energy required for its operation (reduction of mechanical losses), provide good gas exchange process and design a reliable, less service-demanding construction. The volumetric efficiency an engine can achieve with traditional poppet valves is limited. The valve heads block the

flow of gases and their choking effect decreases the efficiency of the gas exchange process. This present research concentrates on the examination of the possibilities of a novel design of a valve using swaying motion to better utilize the possibilities in engine downsizing, as shown in [1].

1.1 Introducing the Novel Valve Concept

In engines equipped with poppet valves, the incoming fresh mixture needs to get around the valve head which can be seen in Figure 1. This hinders flow capabilities of the intake port. Mass flow is reduced that in turn limits the power delivery in general. On the exhaust side, the situation is about the same. In this case, the spent gases face a flow condition that delays the emptying of the cylinder that results in greater pumping loss and fuel consumption.

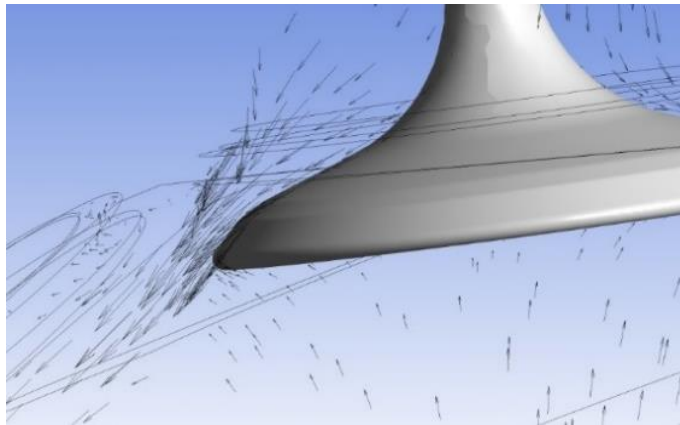

Figure 1

Flow vectors around the valve head

The devised solution uses a pivoting valve element for both the intake and exhaust ports to quickly open large cross-sections for the flowing gases, without making them to change direction. The familiar valves, cams, rockers, valve springs, etc. from the previously used control systems are eliminated. An important aspect of the construction is that the parts could be manufactured using known and widespread technology, so that the production problems and costs are as small as possible. The layout of the swinging valve system is shown in Figure 2, and the details of the valve system are discussed in [1] [3].

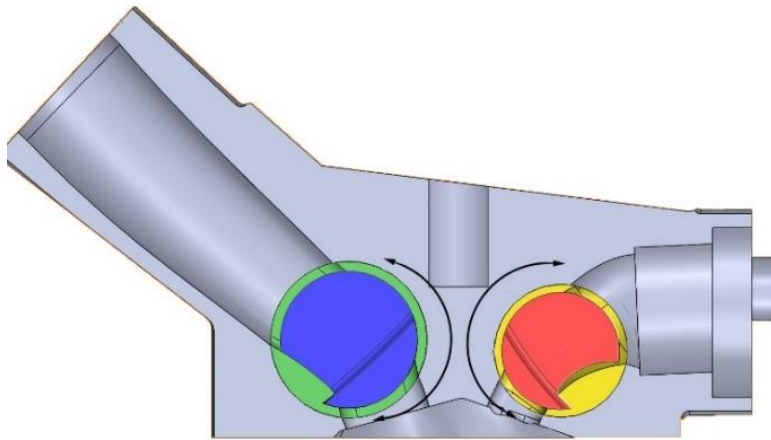

Figure 2
Swinging valve arrangement

2 Objectives of the Project

Thermodynamically the poppet valve engines must make a compromise between efficient combustion chamber shape and suitably sized valves with adequate flow capability. To reach a given performance level, the four-valve arrangement is the best compromise but the space required by the valves in the cylinder head reduces the squish area. Increasing squish area would otherwise improve combustion efficiency and fuel consumption but on the contrary, valve size or in worst case the number of valves should be decreased. With the new swinging valve design high compression ratio can be reached and the squish area can be maximized to increase the speed of combustion and decrease the danger of detonation. In comparison to poppet valve designs an engine equipped with the new valve system may have the following features:

- Reduced flow losses
- Reduced power requirement to operate valves and valve gear
- The value of the force to open the exhaust valve is independent of the combustion chamber pressure
- A more complete purging of combustion chamber
- Possibility to apply greater ports
- Improved volumetric efficiency
- Better power, ideally over a wider range of engine speeds
- Higher possible maximum engine rpm

- Greater squish area
- Piston face without valve pockets to improve combustion efficiency and reduce the formation of HC emission
- Higher possible compression ratio because of the absence of the hot exhaust valve heads
- Better burning characteristics and lower emissions due to improved combustion
- Higher tumble ratio due to the positioning and flow pattern of the valve
- Higher combustion speed due to increased squish and tumbling action
- Due to increased tumble, burn rates are improved therefore less pre-ignition is required
- Enhanced stratified combustion
- With electronic valve drive Miller and Atkinson cycles can be applied in different speed regimes of the engine
- Better power-to-weight ratio due to the improved volumetric efficiency and lighter valve system

3 Literature Review: Historical Background of Non-Conventional Engine Valves

As described in [4], the most important development from the early days of motor industry until the era just after WW II. Lot of detail information can be gathered from [5] and [6] as well. The common feature of all is that they rotate continuously at a speed directly proportional to the crankshaft rotation speed. These can be divided into four groups:

Mixed (radial/axial) flow rotary valves:

In these designs there is a single valve that contains both the intake and exhaust passages. The flow must have an approximately 90 degrees change of direction within the valve body. Most recent practical development was the Bishop Rotary Valve designed and tested to operate in a Formula 1 engine [7] [8].

Side ported valves:

There may be a single common valve for both the intake and exhaust flow control. The flow path is formed by the cutaways machined into the side of the valves. Constructors have been using this solution since the 19th Century and this kind of assembly even reached Formula 1 beside other car applications [8] [9].

Radial cross flow rotary valves:

The cutaway breaks through the valve body forming a symmetrical part. The flow of gases passes through the valve body. Due to the constant rotation, there are strong vortexes at the opening and closing edges limiting its flow capability. Information on examples can be found in [10], though a working sample of this principle was created in Obuda University in 2002 by Z. Boruzs.

Rotating cylinder head type valves:

In these systems the cylinder head had one or two channels that lined up with their respective ports during its rotation. The timing of the rotation exactly matched the requirements of the four-stroke working principle. This concept was proved to be successful earlier in a torpedo engine and in a world speed record motorcycle. [5] [6].

4 Materials and Methods

4.1 Research Completed so far

In previous stages of our research a cylinder head fitted with the novel pivoting valves had been designed and manufactured to establish its flow parameters. The information gathered had been compared to the relevant data obtained from the same engine's original cylinder head that used poppet valves. The engine data used for the research can be found in Table 1.

Table 1
Parameters of the base engine

Configuration:	4-stroke, 4 valve, 90-degree V2,
Bore x Stroke:	81 x 62.6 mm
Swept volume:	0.645 litre
Maximum Power:	60.5 kW / 9000 rpm
Maximum Torque:	68.2 Nm/ 7500 rpm
Highest engine speed:	11000 rpm

The previously mentioned flow test had been carried out using a Superflow SF600 flow test bench. Swinging valves produced better flow rates: 14.5% improvement for the intake valve and 11.36% improvement for the exhaust valve over the poppet valves with the same flow cross sectional areas. Description of the flow test and the equipment used can be found in [11]. The results were then further processed in a 0D/1D engine modelling environment where both engines were recreated and the base engine had been validated against performance measurements obtained using a dynamometer (Figure 3).



Figure 3

Dynamometer test of the base engine

Results from the engine simulation exposed engine performance improvements beyond expectation. This is best illustrated by the performance curve shown in Figure 4 in [12].

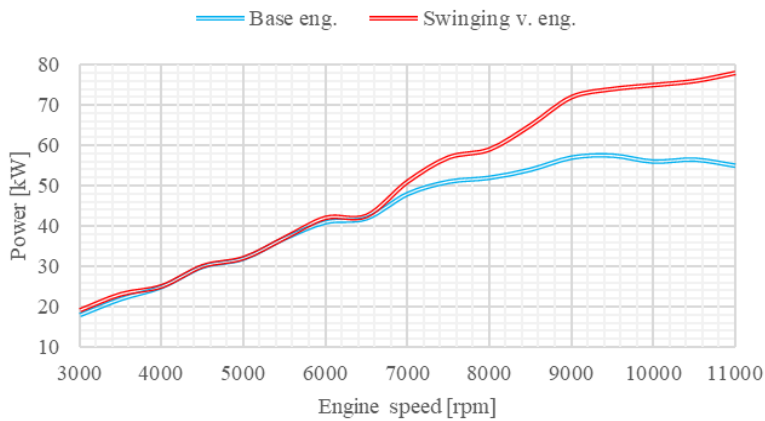

Figure 4

Comparison of simulated engine power obtained using pivoting valve system and the poppet valve base engine

4.2 Core Idea behind the Research: Stratified Charging and the Swinging Valve

Before combustion is started by the spark plug a suitable air-fuel mixture has to be produced in the combustion chamber. In the past carburetors served this purpose but with advancements in technology Direct Fuel Injection (DFI) has been developed. In this latter case the fuel injector is placed in the cylinder and injects fuel during the compression stroke where it evaporates. The specific position of the injector and the in-cylinder air movement prevents the formation of a homogenous cylinder charge and assists that most of the injected fuel reaches the spark gap by the end of compression stroke. By the time ignition takes place a cloud of easily ignitable fuel rich mixture surrounds the spark plug. The remaining combustion chamber volume consist much less, if any, fuel. The average fuel content across the combustion chamber is far from stoichiometric, resulting in lambda values in the range of 1.6-2. This improves fuel efficiency and decreases CO₂ emission. To facilitate the uneven distribution of fuel in the combustion chamber, the tumbling motion of the fresh mixture within the cylinder needs to be improved. Tumble is a rotational motion of the fresh charge around the axis that is perpendicular to the cylinder symmetry plane and normally parallel with the crank shaft (Figure 5). It is also enhanced by the inclination of the intake port. In poppet valve engines shallower port angles, produce greater tumble effect but sacrifice volumetric efficiency.

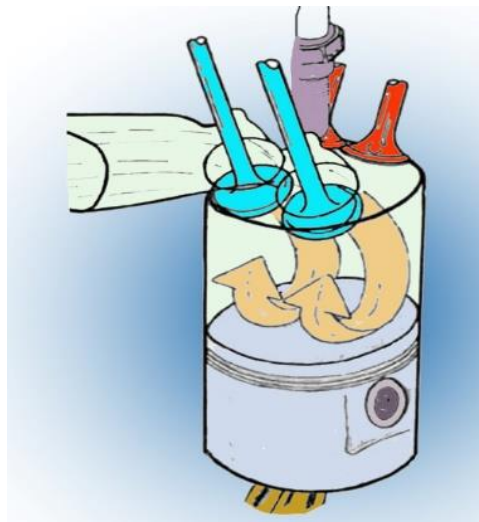

Figure 5

Formation of in-cylinder tumble vortex flow

The swaying valve, that our research is focused on addresses this problem since it directs the incoming intake flow in a path that enhances tumble while keeping volumetric efficiency high. So far, vortices required for tumble have been

generated by intake port flow deflectors. As is stated in [13] these devices constrain engine efficiency and add to structural complexity that in turn increases system failure possibility.

5 Numerical Simulation

Since the intake process has a substantial effect on the complete working cycle of the engine, we made a comparative test regarding the original and the newly devised valve systems. To follow the process with dedicated measuring equipment would have required an apparatus that is very difficult to obtain and is beyond our technical possibilities. Hence, we used CFD technique for the examination of the delicate flow structures within the cylinder of a working engine. This solution yielded more accurate results than could have been achieved by measurements. In the current phase of preliminary design, the CFD simulation proved to be of suitable accuracy to pinpoint the significant differences between engines equipped with swinging valves and poppet valves while also appropriately identifies the strengths of our construction even without validation. Certainly, it is going to be inevitable to use high tech measuring techniques in the upcoming phases of development.

5.1 Creating the Flow Space

Therefore, the purpose of the numerical model was to simulate the intake flow entering the cylinder in the case of both valve systems therefore, a CAD model of the poppet valve cylinder head was generated. In order to get the exact shape of the ducts to be modelled in the cylinder head, moulds of the intake and exhaust ports were modelled in a two-component silicone rubber. The detailed description of the process can be found in [14].

5.2 Model Refinement and Meshing

Using the above methods, the CAD model was transferred to the Ansys SpaceClaim software, where it was prepared for the flow simulation. This included eliminating any model errors in the created 3D geometry that arise due to data transfer irregularities between the two program packages. These errors are not visible to the naked eye and cause "leakage" of the model and fail to create the closed flow space required for numerical simulation. This task was completed with a built-in function of the software.

In order to simplify the geometry small surface elements, that are difficult to mesh, were eliminated and a vertical plane of symmetry was created. This way the size of the model was halved, and the time required for the simulation was also

significantly reduced, although it still took several days. It is important that the model was not only simplified by using the plane of symmetry, but was divided into suitable volumes in preparation for meshing. This was necessary due to the flow modelling [14].

From the refined poppet valve model, volumes consisting of tetrahedral and hexahedral cells were created. The yellow-coloured part in Figure 6 must consist of hexagonal elements, because this is the only way to properly model the piston movement. Since the cylinder, the combustion chamber and the intake pipe can be considered static, we used the traditional tetrahedral mesh in these volumes.

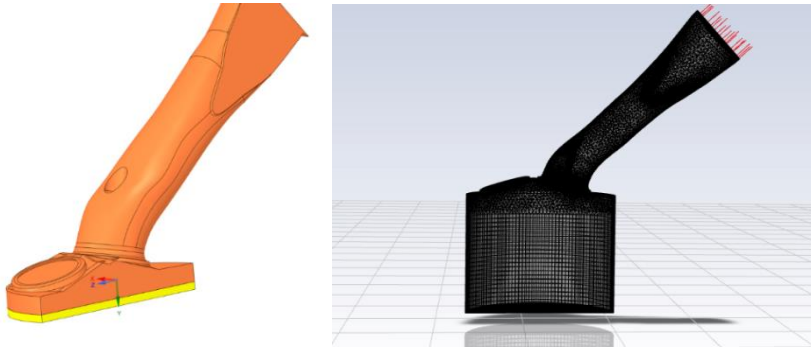

Figure 6

Poppet valve flow space divided into sub-volumes for simulation (left) and the resulting grid (right)

The same procedure was utilised with the swinging valve cylinder head. The flow volume was divided into several separate parts, in which the most suitable method could be used for the calculations (Figure 7). Tetragonal mesh was applied in the intake pipe and valve body, while predominantly hexagonal mesh in the combustion chamber, and swept hexagonal mesh in the cylinder. Near the piston only swept cells, could be used as only this solution enables the piston to be simulated as a moving wall.

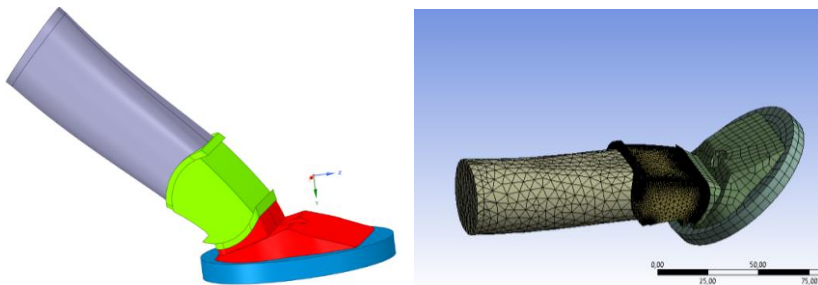

Figure 7

Sub-volumes created for the swinging valve simulation (left) and the resulting grid (right)

5.3 Grid Independence Test

Finding the right grid spacing presented the greatest challenge: it took considerable time to achieve a stable simulation. The difficulty was caused by the edges of the poppet valves that prevented a uniform cell size to be formed on the moving face symbolizing the piston. Based on data found in [16], the quality of meshing has a significant impact on the results obtained, therefore several cell sizes were tested during meshing. For this purpose, we used the swinging valve 3D model. By refining the mesh beyond the cell size absolutely necessary for the stability of the calculation, the flow values changed only in the vicinity of the walls and only the location of the stagnant gas mass changed. It was observed that the cell size needed to be smaller than a critical value to avoid the distorting effect of the valve edges, and enable stable simulation. Further reducing the mesh cell size over the necessary minimum dimension resulted in unchanged flow values (Figure 8). Based on this observation, the poppet valve cylinder head model was created using 0.5 mm cell size. On the grounds of keeping every possible detail identical between the different models, the same mesh sizing had been adopted for the simulation of the swinging valve system. The meshing parameters, as well as the time characteristics of calculations for different mesh densities, are included in Table 2.

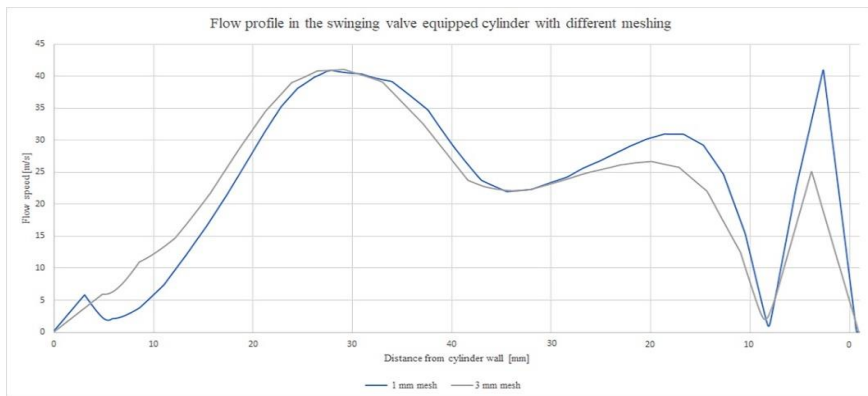

Figure 8

Flow results obtained using different mesh sizes

Table 2

The main characteristics of the mesh types used in different valve arrangements

Cell size on the piston surface	Number of nodes	Number of cells	Calculation time:	Number of time steps:	Length of time steps:
3 mm (swinging valve)	169580	563825	4.85 h	500	1.33×10^{-5} sec

1 mm (swinging valve)	602538	2224769	20.21 h	500	1.33×10^{-5} sec
0.5 mm (poppet valve/swinging valve)	473182/ 415367	1517665/ 1460337	64.7 h	1000	6.66×10^{-6} sec

6 Results

6.1 Simulation Set up

The calculations were targeted at an engine speed of 7000 rpm. The choice of this specific engine speed was made using the results presented in [3], [12] where it was demonstrated, using extensive OD/1D simulation, that this was the speed that corresponded to the highest delivery ratio. Parameters used for the calculations can be found in Table 3.

Table 3
Parameters used in the OD/1D engine simulation

Engine speed of the greatest delivery ratio	7000 rpm
Crank angle for the greatest piston speed	75 ATDC
Value of greatest piston speed	23.5 m/s

Ansys Fluent was utilized to complete the simulation. Dynamic meshing was exploited and user defined functions (UDF) were created for both valve systems to model the poppet valve and swinging valve motions. The only opening to the atmosphere was a pressure outlet where flow direction was kept undefined. This way in-cylinder pressure variations could determine the actual particle movement, while in the same time, a more robust solution stability could be achieved. The piston movement was replicated by implementing the layering technique. All moving boundaries were treated as “rigid bodies” and remeshing technique was used around the valves, plus surfaces adjacent to the pivoting valve body were treated as “deforming walls”. The simulation was set-up as transient with details already mentioned in Table 2. Turbulence was modelled by using shear stress transport (SST) using the $k-\omega$ scenario that is able to capture wall turbulence as well as flow phenomenon in the free stream [15]. Second Order Upwind solver was used whereas relaxation factors needed to be decreased appr. 20% to achieve converging results during subsequent time steps.

6.2 Calculation Results

To analyse the results of the calculation, it was necessary to display the rotating gas masses. This could be done by representing the flow vectors and the unidirectionally moving surfaces together (Figure 14). This image shows that by the end of the induction stroke, several centres of rotation have formed in the flow space. Their location is chaotic, which does not help directing the fuel in such a way that it is focused in the vicinity of the spark plug at the end of the compression stroke.

To get numerical values on the degree of vorticity in the poppet valve equipped cylinder head, a plane passing through the axis of the valve was created. With the combined use of vector and contour representation, the rotating gas masses and the stationary portions could be identified. As can be clearly seen in Figure 9, despite the closing valve and the piston stopping at the bottom dead centre, the inflow into the cylinder takes place at a speed of 0.5M. Using a graphical representation of the obtained results, it could be deduced that the flow with the traditional valve is chaotic. The centres of rotation producing the most intense vorticity were selected to lay measuring lines across them. Using 1000 measurement points per line numerical results were obtained, which were represented in a diagram shown in Figure 10.

The same procedure was repeated using the swinging valve system. From the graphical results a more coherent flow structure emerged. In contrary to the chaotic streams of the poppet valve, a very orderly flow pattern was observed, which resembled a curved torus. The direction of the swirl pointed towards the spark plug, which would be ideal for a stratified charge engine to be developed in the future. The rotating ring of air is directed towards the cylinder head which is really beneficial in the context of stratified charging, lean burning engines (Figure 11).

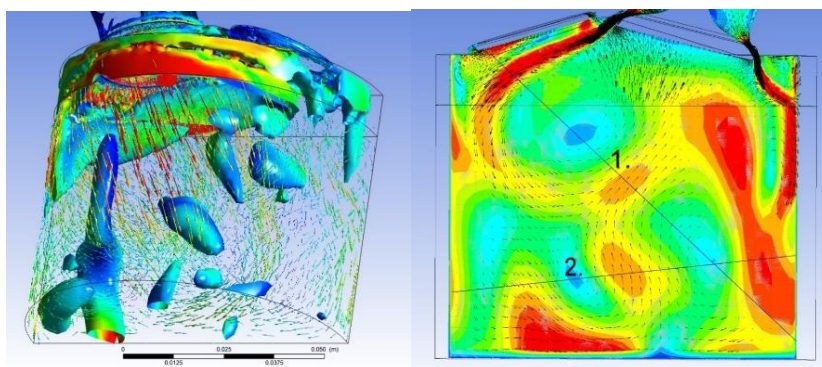

Figure 9

Representation of chaotic flow structures (left) and the measuring lines used to determine numerical values in the plane of the valve stem (right)

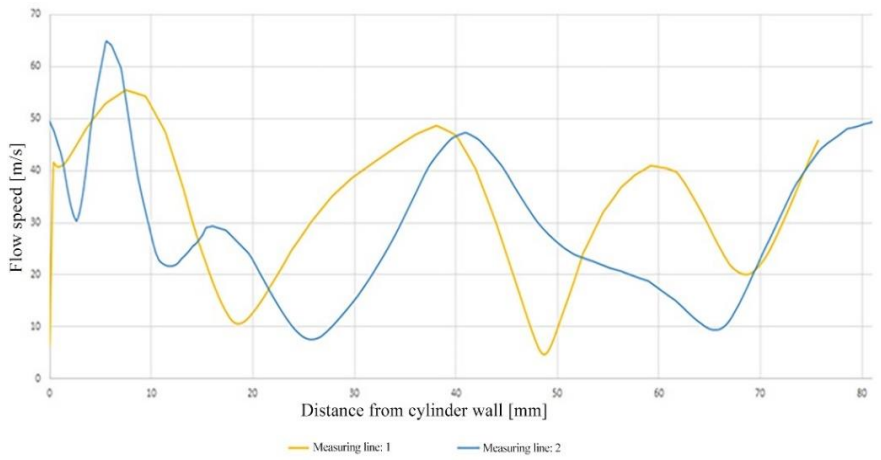

Figure 10

Flow profiles along different measuring lines in the poppet valves equipped cylinder model

In order to extract numerical results from the swinging valve model, a display plane was created that coincided with the symmetry plane of the cylinder (Figure 11). Then, as was shown at the poppet valve system, a measuring line consisting of 1000 data points, was laid across the centers of the vortices that, in this case, could be easily identified. The results were displayed in a graph showing a distinctly different flow distribution than the one obtained in the poppet valve model (Figure 12).

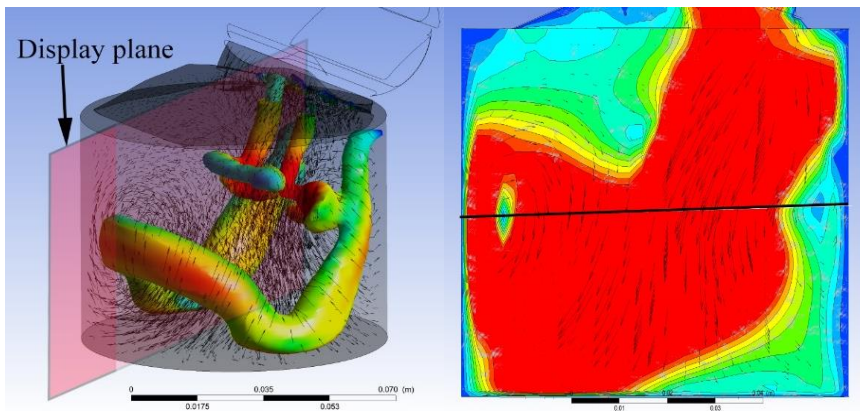

Figure 11

Torus like flow structure is formed in the swinging valve equipped cylinder model (left) and the measuring line used to determine numerical values in the display plane (right)

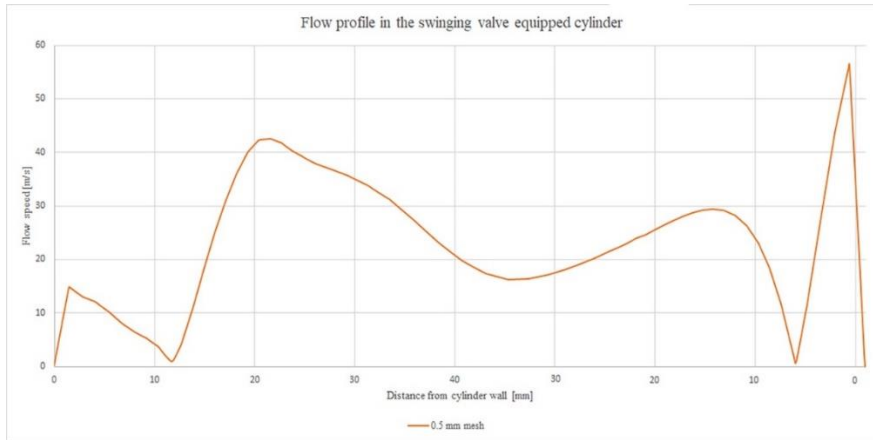

Figure 12

Flow profile along in the display plane along the measuring line in the swinging valve equipped cylinder model with 0.5 mm mesh size

7 Discussion

As can be found in [17], the flow field in the cylinder can be examined as a rotating solid body which centre of rotation is the stationary mass in the centre of the vortex. Using this reasoning, the rotation speed of the vortices can be determined according to the well-known calculation:

$$n_{TR} = \frac{30v}{r\pi} \quad (1)$$

Where:

n_{TR} : tumble rotational speed [rpm]

v : vortex peripheral speed [m/s]

r : vortex radius [m]

With the help of equation No. 1, the Tumble Ratio (TR) can be determined in relation to the engine speed according to [18][1]:

$$TR = \frac{n_{TR}}{n_{ck}} \quad (2)$$

Where:

TR: Tumble Ratio

n_{TR} : Tumble rotational speed [rpm]

n_{ck} : Engine crank shaft rotational speed [rpm]

As is stated in [1], tumble is defined by the tangential component of the incoming charge. Since all possible steps were taken to keep the swaying valve parameters identical to the poppet valve specifications both valve systems share the same inclination angle of 12 degrees measured from the symmetry axis of the cylinder. Therefore, the calculation methods presented in the aforementioned literature would not produce meaningful results in our case.

Since the primary goal of our research is to determine the differences between the traditional valve system and the rocker valve system, we have therefore introduced the Relative Tumble Rate, with which we could get information not only about the ratio of the vortex spaces and the crankshaft speed, but also about the size of the gas mass involved in the movement:

$$RTR = \frac{TR}{R_{RF}} \quad (3)$$

Where:

RTR : Relative Tumble Rate

R_{RF} : Relative Flow Radius

The relative flow radius can be expressed as the ratio between the instantaneous tumble radius and a characteristic size of the cylinder space, which in this case is ideally the radius of the bore. The instantaneous radius can be calculated from the graphical analysis of the numerical data (Figure 8), while the radius of the cylinder is obvious.

$$R_{RF} = \frac{R_{instl}}{R_H} \quad (4)$$

Where:

R_{instl} : Instantaneous Tumble Radius [m]

R_H : Radius of cylinder bore [m]

Using the above relationships, we determined the Relative Tumble Rate for both valve systems. The calculations showed that in the swinging valve cylinder head, the Relative Tumble Rate is 36.69% higher on the side above the exhaust valve, and 10.45% on the side closer to the cylinder wall. The detailed results of the calculations are summarized in Tables 5 and 6.

Table 5
Flow parameters of poppet valve equipped cylinder head

Parameter	Tumble direction: right	Tumble direction: left
R_{inst} [mm]	6.288	9.759
v [m/s]	114.114	134.191
n_{TR} [rpm]	173283.5	131304.7
RTR	3.751	4.411

Table 6
Flow parameters of swinging valve equipped cylinder head

Parameter	Tumble direction: right	Tumble direction: left
R_{inst} [mm]	51.047	19.192
v [m/s]	155.991	148.25
n_{TR} [rpm]	29180.857	73766
RTR	5.127	4.873

Conclusions

From the outcomes of our research, it is obvious that the swinging valve concept provides more favorable tumble properties, that may be ideal for stratified mixture formation, in GDI engines. The slower rotating greater mass of fresh gas, that revolves opposite to the crank shaft rotation, creates a situation where the fuel being injected, will not be broken up by the fast spinning vortices, shed off from the valve edges. Therefore, fuel can be concentrated around the spark plug with more ease and that may assist the production of more sophisticated lean burn engines. It has been demonstrated that engines employing valves performing swaying motions, surpass poppet valve cylinder head equipped engines. Swinging valves offer simpler solutions, to achieve the required performance characteristics, with a reduced engine displacement, thus, perfectly fitting into current engine downsizing concepts.

References

- [1] Kovacs, L., Szabo, Sz.: Challenges of Engine Downsizing, The Publications of the XXVII. microCAD International Scientific Conference, University of Miskolc, 21-22 March, 2013, Miskolc
- [2] Kovacs, L.: Analytical examination of the valve control system of a high-speed internal combustion engine, GÉP 2014/1, 2014, LXV. évfolyam, pp. 28-33
- [3] Kovacs, L., Szabo, Sz.: Comparative study on the improvement of the gas exchange process efficiency of a high-speed IC engine using swinging valve. *Analecta Technica Szegedinensia*, 2019, 13(2), pp. 28-37

-
- [4] Hunter, M. C. I.: Rotary Valve Engines, London, UK, Hutchinson's Scientific and Technical Publications, 1946
- [5] Douglas, S.: Museum of Retro Technology: Power Generation, Unusual Internal Combustion Engines: Rotary Valve IC Engines, Available at: <http://www.douglas-self.com/MUSEUM/POWER/unusualICeng/RotaryValveIC/RotaryValveIC.htm>, Accessed on: 24.01.2023
- [6] Wood, J.: Aspin Rotary Valve Engines, Available at: <http://www.aspin.info>, Accessed on: 09.01.2023
- [7] Wallis, T.: The Bishop Rotary Valve, AutoTechnology, Motorsport Technology Special 2007, pp. 2-5, FISITA, 2007
- [8] Horrocks, G.: A Numerical Study of Rotary Valve Internal Combustion Engine, Unpublished PhD Dissertation, The University of Technology, Sydney, 2001
- [9] Grimonprez, D.: The story of Guy Nègre and MDI, Available at: <https://sites.google.com/site/rijdenopperslucht/home/menu-en/mdi-en/mdi-bedrijf-en/guy-negre-en?tmpl=%2Fsystem%2Fapp%2Ftemplates%2Fprint%2F&showPrintDialog=1>, Accessed on 11.01.2023
- [10] Coates International, Ltd. The Coates Spherical Rotary Valve (CSRV) System, Available at: <http://www.coatesengine.com>, Accessed on: 09.04.2023
- [11] Kovacs, L., Szabo, Sz.: Improving the power characteristics of an Internal Combustion Engine with the help of a 0D/1D engine model, ANNALS of Faculty Engineering Hunedoara– International Journal of Engineering, 2015, Tome XIII – Fascicule 2, 83-88
- [12] Kovacs, L., Szabo, Sz.: Test validated 0D/1D engine model of a Swinging Valve internal combustion engine, Multidisciplinary sciences, Vol. 11, 2021, 4 sz, pp. 266-277
- [13] Kaplan, M.: Influence of swirl, tumble and squish flows on combustion characteristics and emissions in internal combustion engine-review, Amasya University Technology Faculty, Mechanical Engineering Department, Published by Editorial Board Members of IJAET, 2019, e-ISSN: 2146-9067
- [14] Kovacs, L., Szabo, Sz.: Examination of tumble rate with two dissimilar engine valve systems, GÉP (0016-8572): LXXIII 2 pp. 5-10, 2022
- [15] Andrych-Zalewska, M.: Simulation tests of selected gas flow parameters through combustion engine valves, Combustion Engines, 183(4), pp. 21-28, 2020, <https://doi.org/10.19206/CE-2020-404>

- [16] Hamid, M. F., Idroas, M. Y., Sa'ad, S., Teoh Yew Heng, T. Y., Mat, S. C., Alimuddin, Z., Shamsuddin, K. A., Shuib., R. K., and Abdullah, M. K.: Numerical Investigation of Fluid Flow and In-Cylinder Air low Characteristics for Higher Viscosity Fuel Applications Processes 2020, 8, 439; doi:10.3390/pr8040439, ISSN 2227-9717
- [17] Falfari, S., Brusiani, F., Pelloni, P.: 3D CFD analysis of the influence of some geometrical engine parameters on small PFI engine performances – the effects on the tumble motion and the mean turbulent intensity distribution, 68th Conference of the Italian Thermal Machines Engineering Association, ATI2013, 11-13 September 2013, Bologna, Italy, 2014, Energy Procedia 45, 701-710
- [18] Bozza, R., De Bellis, V., Fantoni, S. and Colangelo, D.: CFD 3D Analysis of Charge Motion and Combustion in a Spark-Ignition Internal Combustion Engine under Close-to-Idle Condition, E3S Web of Conferences 197, 75° National ATI Congress – #7 Clean Energy for all (ATI 2020) 2020, Rome, Italy, September 15-16, 2020
- [19] Falfari, S., Brusiani, F., Bianchi, G. M.: Numerical analysis of in-cylinder tumble flow structures –parametric 0D model development, 68th Conference of the Italian Thermal Machines Engineering Association, ATI2013, 2014, Energy Procedia 45, 987-996