

THE MAIN TYPES OF KARREN DEVELOPMENT OF LIMESTONE SURFACES WITHOUT SOIL COVERING

MÁRTON VERESS

„Berzsenyi Dániel” College, Department of Geography
9700 Szombathely, Károlyi G. tér 4.

Abstract: Mostly based on examples studied in the Austrian Totes Gebirge limestone surfaces without soil covering can be identified into categories regarding where the karren development took place, what is the position and shape of the developed karstic surface. Sub-types of karren, variation of karren and processes of solution within these are differentiated in the karren types. Forms originated by solution are categorized and suggestions are offered for the nomenclature of hitherto unspecified processes and forms.

1. Introduction

The morphological specification of karren has been already completed (MONROE, W-WATSON, H., 1972, BÖGLI, A. 1976, FORD D. C.-WILLIAMS, P. W. 1989, BALÁZS, D. 1990). The latest surveys analyze the factors that influence karstification. MOTTERSHEAD, D. N. (1996) analyzed the relation between certain karst forms and gradient of slope, GLEW, J. R.-FORD, D. C. (1980) between the length of rillen and gradient of slope. CROWTHER, J. (1996) analyzed the roughness of karren forms.

The specification of the phenomena of karstification and the genetic explanation of the forms can happen with the consideration of the kind of geometrical shapes generated on the interface of the solvent and the dissolved rock surface. (VERESS, M.-PÉNTEK, K. 1992, VERESS, M.-PÉNTEK, K. 1994). In this paper with respect to this principle those solution processes are classified - mostly using Totes Gebirge, Dachstein and Julians Alps examples - that are responsible for the development of karren types and their constituent morphological elements. The basis of the classification is the location (on the ground surface or in the rock) extension and position of the interface of the solvent and the dissolved rock (the location of the solution). Within the classification suggestions will be offered for the extension of the nomenclature of the karren. There have been attempts for classification observing this principle (VERESS M. 1995), but then only the types of solution and the processes of solution were specified. The types of solution (sub-types in this paper) were not classified into the karren types.

Karren development may occur on surfaces with or without soil covering. In this paper three types karren development, the surface-, the vertical- and the subsurface karren development will be specified and their forms analyzed.

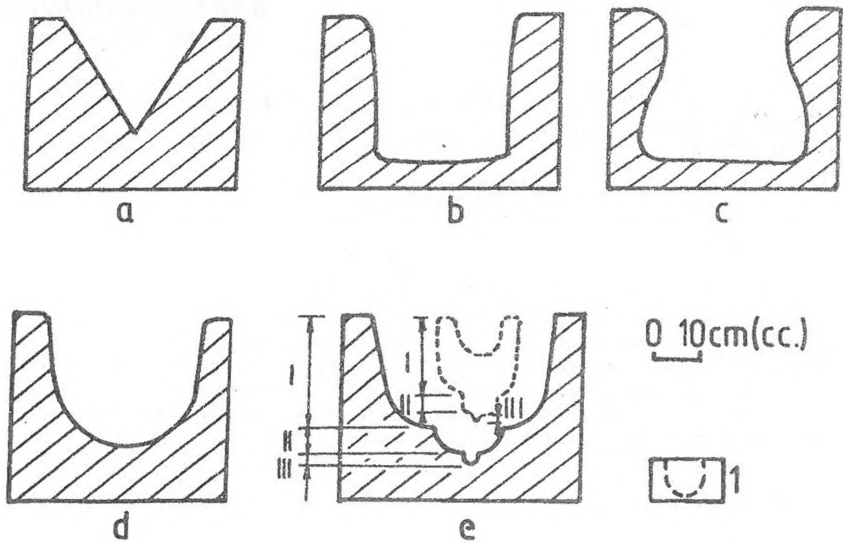

Fig 1: Various cross sections of simple (a-d) and composite (e) troughs
 Legend: I, II, III trough types, 1: older troughs

2. Surface Karren Development

The surface karren development occurs on the rock surface.

2.1. Surface solution

Compared to lateral solution vertical solution is relatively small. It occurs primarily on bedding plane surfaces. It results in the increasing roughness of the surface, edges, crests, rises, cones, towers and occasionally blocks of debris are left behind.

It may occur that steps develop resulting from selective solution. The fronts of the steps retreat more or less parallel to themselves.

Trittkarren surfaces are possibly the results of surface solution where the solution is differently effective on the various points of the surface. Observations hint that the heel prints may be responsible for other karren forms (fluting, solution pans.)

2.2 Linear Solution on the Surface

The solution occurs in a strip or line considerably in the vertical direction as well.

Linear solution may be the cause of the development of slope-karren that are composed of various measure long depressions, troughs (rills, runnels, major runnels) that are more or less parallel, various in density.

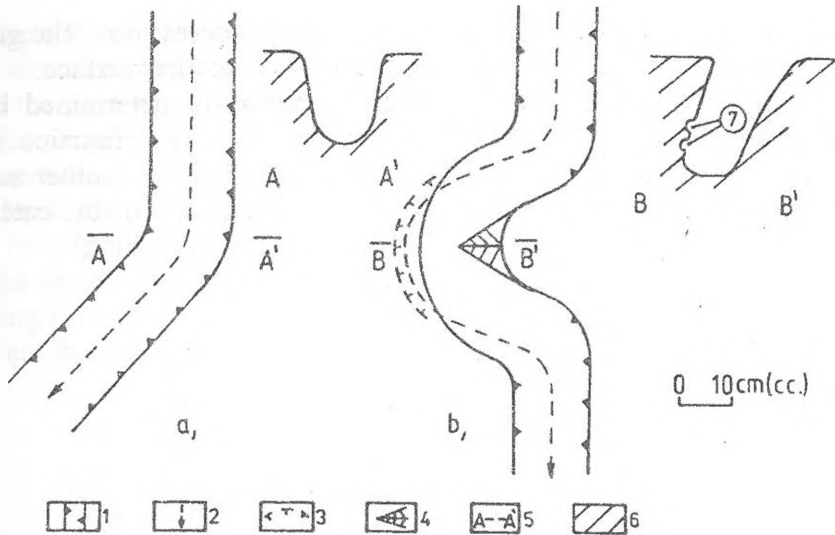

Fig. 2: False meander (a) and true meander (b)
 Legend: 1. vertical trough side, 2. streamline, 3. the edge of concave trough-side, 4. the moderately sloping side of the trough (skirt), 5. cross section, 6. bedrock, 7. scour grooves.

2.2.1. Linear, Straight Solution on the Surface.

The strip of solution is straight, the solvent flowing on the slope forms runnels. The runnels are specified by their dimensions. The small ones are the "rillen" (BÖGLI, A. 1976) rain flutes (esőbarázda, VERESS, M. 1992), the more sizable ones rinnens (BÖGLI, A. 1976), runnels (WHITE, W. B. 1988), flutes (barázda BALÁZS, D. 1990) and solution channels (oldódási csatorna VERESS M. 1992). FORD, D. C.-WILLIAMS, P. W. (1989) separate small sized microrills (developed by solution effect of capillary water) and solution channels. The letter ones are the rillens and different types of runnels. According to WHITE, W. B. (1988) rills (ribbenkarren) develop on slopes where sheet flow, rinnens (rinnenkarren) on slopes, where channel flow takes place. Rillen develop on steep slopes, when sheets of water separate into ribbons, and there will be a jump from laminar flow to turbulent flow because of disruption of boundary layer's continuity (TRUNDGILL, S. 1985). According to KUNAVÉR, J. (1984) rinnenkarren occurred between about 1650-1700 metres height above the sea level.

Rinnens develop on slopes of low angle without soil covering when the flow is banded (WHITE, W. B. 1988). They can also develop on surfaces covered with soil (FORD, D. C.-WILLIAMS, P. W. 1989.)

Troughs can be simple and composite as for their cross section (Fig. 1). Both simple and composite troughs can be major troughs. These letter are

solitary big (width and depth exceeding one meter) depressions. The gradient of the bottom of the major troughs is less that of the mother surface.

The shape of the simple troughs is probably determined by the quantity of the solvent as a function of time. This is a function of the discharge of the solvent (a function of the gradient of the mother surface) and a function of recharge (a function of the morphology of the catchment area, the thickness of the snow covering, the intensity of melting).

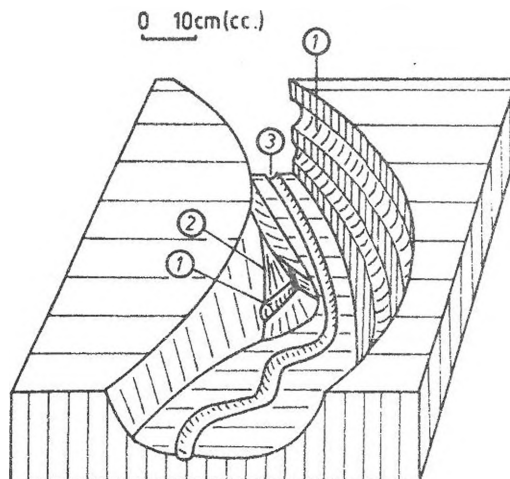

Fig. 3: The slip of a bend (after a photo)
Legend: 1. scour groove, 2. skirt, 3. type III trough

In active periods due to the gradual decreasing of the solvent solution is spread over a decreasing strip. A V-shaped trough develops. The trough will be V-shaped if solvent is recharged laterally. In these cases rounded inter-trough edges, rises, crests develop. It may occur that troughs develop on the crest between the troughs (crest-trough).

At constant discharges for longer periods the development of wide bottomed, vertical walled troughs can be expected. It is supposed that at quickly decreasing discharges half-circle or U-shaped (concave walled) troughs develop. Overhanging walled downwards widening troughs develop if the flow of water in the trough is steadily stabilized.

The described simple troughs can be easily said from the composite ones (Fig. 1, Photo 1) that are called *ineinandergeschachtelten* forms by LECHNER, J. (1953).

A sharp decrease of the discharge of the solvent and the stabilization of the smaller discharge results that a smaller (type II) trough develops in the original (type I) trough followed by an even smaller one (type III). Though this classification has a meaning only in the case of a composite

development of the troughs, the individual troughs can be differentiated by their size. The depth and width of the type I troughs is some decimeters, while the type III is only several centimeters. The dimensions of the type II troughs range between types I and III. Such type II trough containing type III size trough may occur that did not develop on the bottoms of type I troughs. It may occur that type III troughs develop on the bottom of type I ones (even more than one can occur in the same trough) or that type III troughs develop elsewhere than in the bottom of a bigger trough. The rate of growing (in width and/or deepening) of the carrier trough can be identical or different from that of the inner trough.

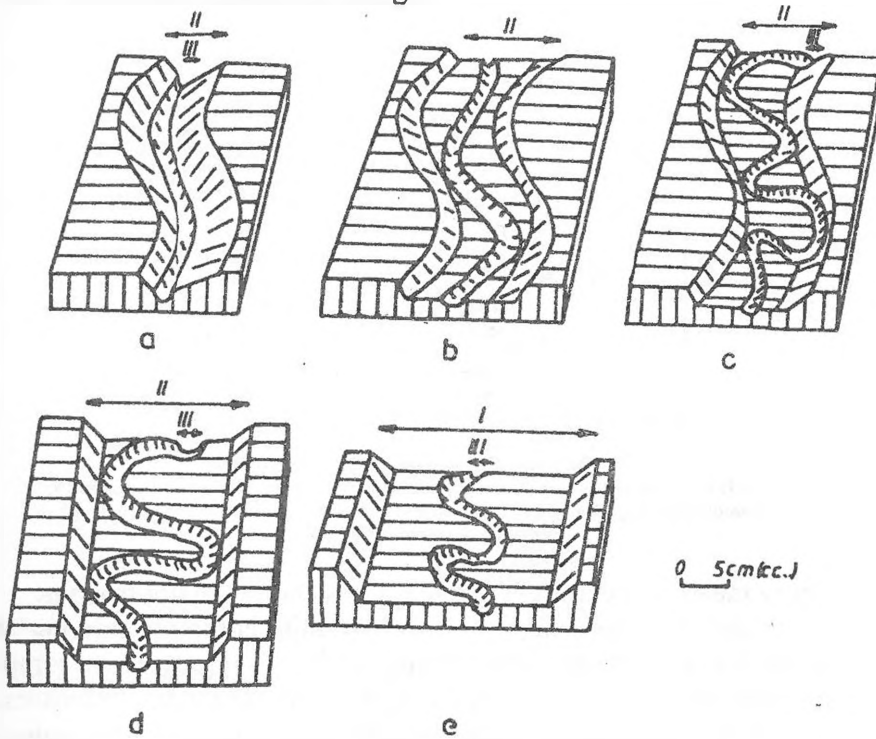

Fig. 4: Inherited meanders of composite karren troughs

Legend: I, II, III, trough types, a: from the beginning forced-meandering similar strained meander, b: from the beginning forced-meandering shifted meander, c-d: strained meander, e. free meander

Solution is not uniform on the bottom of type III troughs (scallop solution). As a result the trough-bottom is composed of dimples of some centimeter in size.

2.2.2 Meandering Linear Solution, and Origin of Meanders

The strip of solution is not straight but of changing direction. The meander-karren was first described by BÖGLI, A. (1976).

The troughs can be bending due to solution that is not following a straight line. The bending can be false meandering or true meandering. Troughs of false meandering are of symmetric cross section at any point. The troughs of true meandering have asymmetric cross sections in bends. (Fig. 2). At the concave side of the meander its wall is overhanging often with side channels (meander scour grooves). At the convex side the trough slope is less than at other parts (skirt) (Fig. 3)

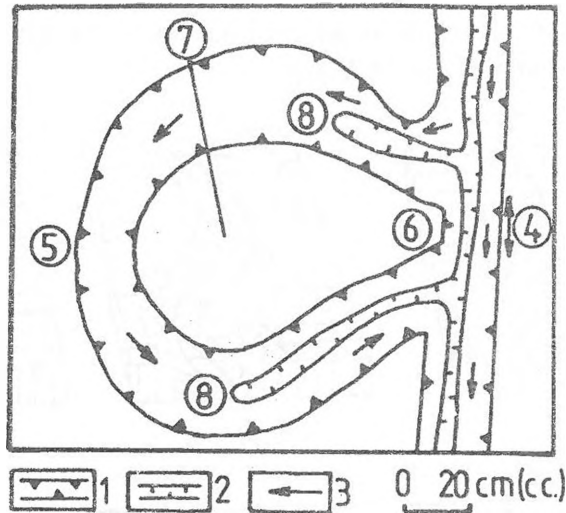

Fig 5: The beheading of a bend (after a photograph)
 Legend: 1: type I trough, 2: type III trough, 3: direction of the fall of the trough-bottom, 4: location of beheading, 5: karren trough oxbow, 6: karren trough neck 7: karren trough inselberg, 8: retreating troughs

Truly meandering troughs are the flutes and the major troughs.

The smaller is the trough the more definite is the meandering and it develops for longer sections. Meandering is mostly increased in composite karren troughs types II and III (the length of the meanders increases, the wavelength decreases. It can be observed that downwards to the bottom the measure of the meandering increases (FRIDTJOF, B. 1954).

Both in the case of the false and true meanders inherited meanders develop. In inheriting it is understood that the meandering of the inner trough is originally staked out by the master trough. Type II and III troughs developing in the false-meandering troughs can forced-meandering. Forced-meandering can be specified as a property of the inner troughs following the bends of the false- or true meanders. Similar (the inner trough is parallel with the master trough) or shifted (the inner trough is not parallel with the master trough) meanders can develop in the inner troughs. The troughs that are truly meandering may be strained (Picture 1) or free (Fig. 4, Picture 2).

In the first case the meanders reach to the walls of the master trough, in the latter case they don't. Type III troughs produce the most varied meandering in their whole length or in sections. Upstream or downstream (recharge from solution pans or discharge to pits) of the strained or free meandering sections of the type III troughs (*Fig 4/e*) the gradient of the slope significantly changes.

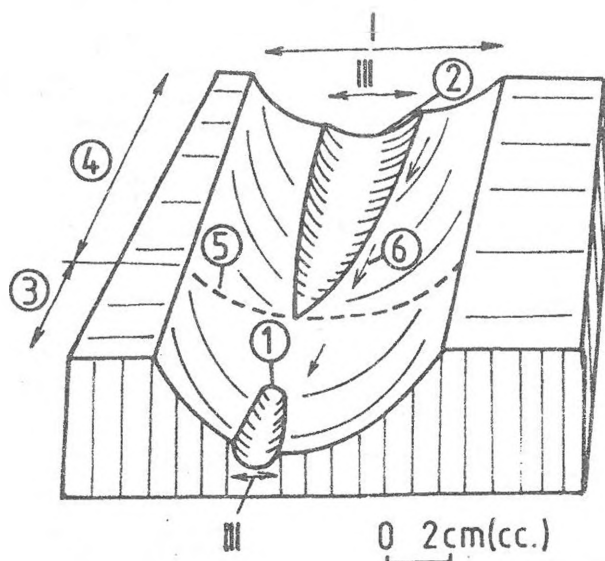

Fig. 6: Development of a watershed and catchment differentiation in young regressive troughs

Legend: type I, III troughs, 1: trough retreating to slope direction, 2: trough retreating against slope direction, 3: catchment area of trough retreating to slope direction, 4: catchment area of trough retreating against slope direction, 5: watershed (divide), 6: direction of the fall of the trough-bottom

2.2.3. The Beheading of a Bend

In well developed bends the karren-trough isle and the karren-trough neck can be differentiated. The beheading of the bend may occur and karren-trough oxbow is resulted that surrounds a karren inselberg (*Fig. 5*). The beheading is probably promoted by cavity development at the neck (neck karren-cavity) and the spilling of the solvent at this point (neck channel).

2.2.4. Trough Regression

The linear solution occurs even more upstream from the actual trough-end, thus the troughs retreat. The deepening that accompanies the

retreating is considerable especially in sections of big gradient (regressive karren canyons). An accented roughening, the pectinated karren develops at the regression of the trough edges and initial troughs (*Picture 3*). (Semipits too develop besides troughs.)

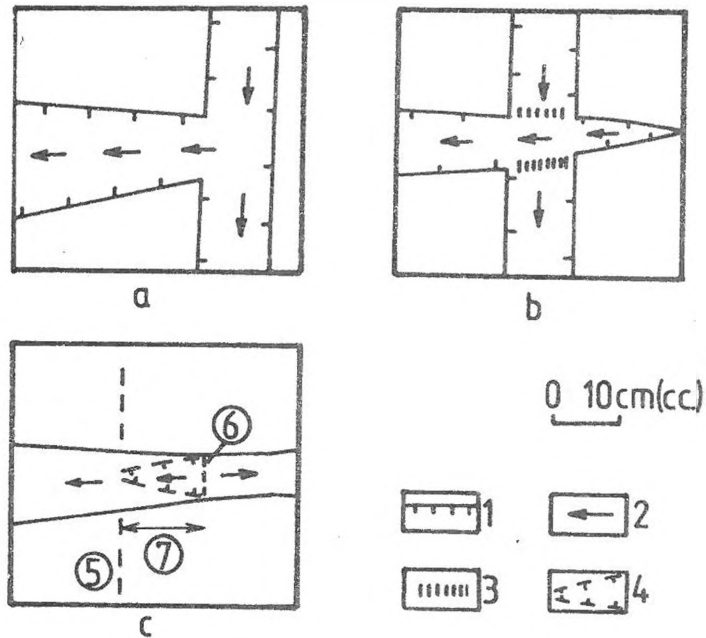

Fig 7: Trough beheadings by regression (after photos)

Legend: a: trough beheading by the contact of the trough-end and the trough-rim, b: trough beheading by trough crossing, c: trough beheading by the contact of trough-ends, 1: trough-edge, 2: slope of the trough-bottom, 3: step, 4: vanished trough-edge, 5: vanished watershed, 6: present watershed, 7: obsequent trough section.

It is frequent that at regressive type II troughs the crests thin out and finally hole through (crest karren natural bridge) (*Picture 4*).

The retreating of the type III troughs that are frequent on the bottoms of type I troughs are often accompanied by bifurcations (*Fig. 10*). Very often the branching off troughs are at right angles at each other rather than acute angle.

The retreating of the troughs is usually slope directed but it can also occur on horizontal surfaces or even against the slope (*Fig. 6*).

It occurs frequently at type II and even more at type III troughs that one trough is perpendicular to the other. The retreating trough-end can decapitate the other trough (*Fig. 7/a*). It can occur that the retreating trough not only decapitate but cross the other (trough crossing *Fig. 7/b*).

The retreating of a karren trough to the other may develop a trough bottom watershed (*Fig. 7/c*). In case one of the cuts more intensively than

the other, that digests the bottom of the other in part and the slope of it will be opposite (obsequent karren trough section). A trough-ruin results if not only the upper but the lower end of the trough is decapitated as well (Fig. 8). Self beheading occurs when the quickly retreating tributary troughs decapitate the main trough (Fig. 9).

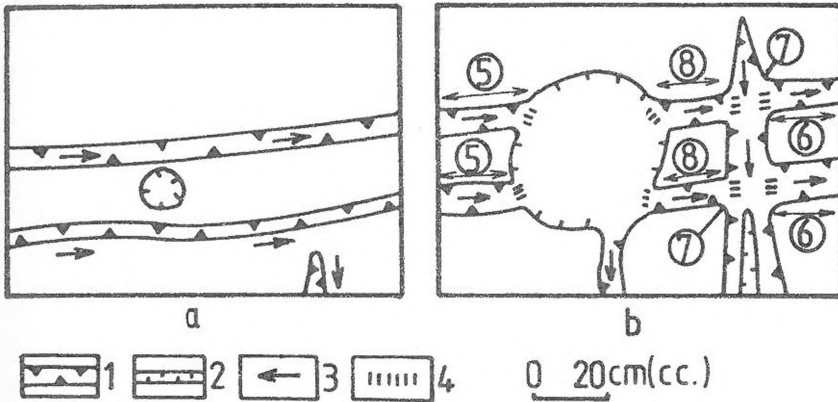

Fig. 8: Beheading by solution pan and trough-crossing (after sketch and photo)

Legend: a: before beheading, b: beheading and trough-crossing, 1: edge of type I trough, 2: edge of type III trough, 3: slope of the trough-bottom, 4: step, 5: trough beheading at the lower section, 6: trough beheading at the upper section, 7: trough-crossing, 8: trough-ruin

It may occur that a type III trough developing diagonally retreats from one of the type I troughs decapitates the other one. The beheading can be simple or composite. A simple beheading occurs when a type III trough has not yet developed within the type I trough (Fig. 10/a). In this case the type III trough branches off downstream in the bottom of a type I trough and retreats in the opposite direction. A composite beheading occurs when a type III regressive trough develops in the type I trough for the duration of the beheading (Fig. 10/b). In this case not only the type I trough is decapitated but the type III trough too. The waters upstream of the place of beheading are discharged by the decapitating type III trough (the water that does not spill over) while waters downstream are not. It shall be noted that the waters in the downstream section may discharge into the type III trough in an increasing ratio. (Because the type III trough that causes the beheading commences to retreat in opposite direction to the section under beheading in the type III trough.)

2.2.5 Karren Terraces and Their Development

Karren terraces are slightly sloping trough-bottom remnants (sloping inwards and downstream) in the insides of composite wide bottomed troughs, that gradually smooth into the side slope of the trough while they continue with sharp rims in the steep side of the lower positioned trough. Though terraces are not only known in troughs. *BAUER, F. (1953)* describes terraces in the solution pans of the Dachstein Mts.

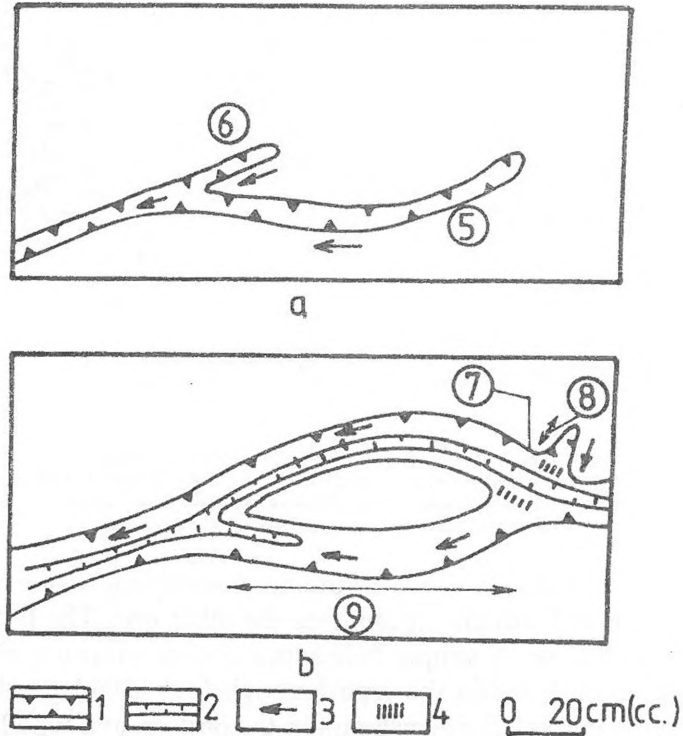

Fig. 9: Self beheading with trough crossing
 Legend: a: before beheading, b: after beheading, 1: type I trough, 2: type III trough, 3: slope of the trough-bottom, 4: step, 5: main trough, 6: side trough, 7: location of beheading (trough crossing), 8: hanging trough, 9: remnant of trough

These forms develop when the development of bigger, older troughs stop or slow down (e.g. the quantity of the solvent decreases or the trough grows too large), the growing of the younger trough (or troughs) digests the bottom of the older trough (or troughs, *Fig. 11*). A similar process takes place when the intensity of the discharge of the solvent occurs. In this case an inner trough develops that retreats from the point of beheading. This may be caused by the piracy (see later) of a pit developing in the trough-bottom

(Fig. 12). Possibly both phenomena have a role in the development of terraces.

Due to the subsequent solution of the trough-bottom the terraces usually do not make continuous surfaces (terrace remnants). It may happen that a terrace appears only at one side of the trough (odd terraces). They can be completely destroyed, in this case in the meeting of differently sloping sides of the trough edges can be observed. Even these edges discontinue (edge remnants) probably caused by lateral recharge of solvent.

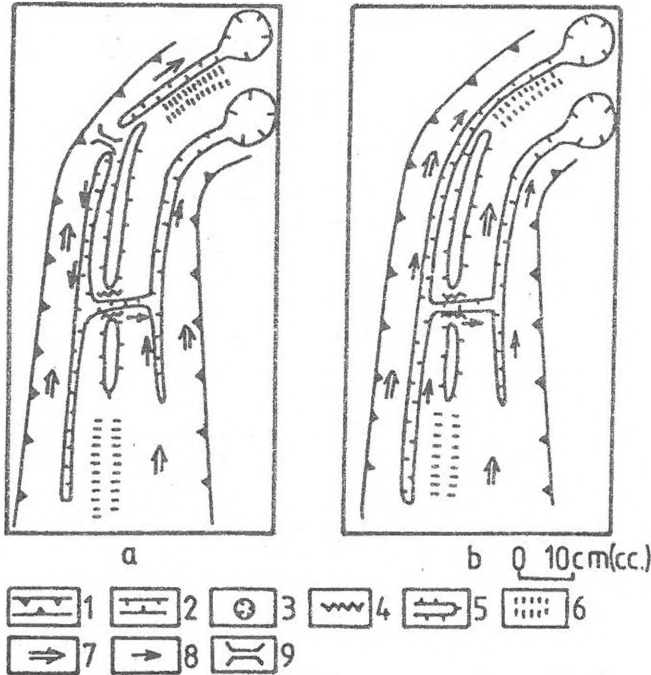

Fig. 10: Simple(a) and composite beheading (after sketch and photo)
 Legend: 1: edge of type I trough, 2: edge of type III trough, 3: pit, 4: diagonal canyon, 5: inter-trough crest, 6: rise between the troughs, 7: slope of the type I trough, 8: slope of the type III trough, 9: trough-bottom watershed

The corrosion terraces show genetic relationship to river terraces or mostly to glacial terraces.

2.3 Spot Solution

Vertical solution is relatively substantial compared to lateral solution. Small area surface solution produces solution pots. The morphology of the solution pots is probably determined by the recharge and discharge of the solvent. If recharge suddenly increases the solution pot will be cut open. The discharge trough of the solution pot on its sharp edge is canyon-like (cut

open karren canyon). It may happen that it's not the water that spills from the solution pot that develops the karren-trough but a regressing trough reaches up to the pot.

When the solution results a solution pot in the inside of a karren trough, trough-bottom solution pot is resulted. These are small size forms their development barred by the size of the trough. Trough-end solution pots and hanging solution pots are connected with karren troughs. These latter are large diameter and small depth pots. Their existence is a condition for the development of large trough systems. Hanging solution pots line up at the sides of the troughs discharged by trough tributaries (mostly characteristic type III troughs).

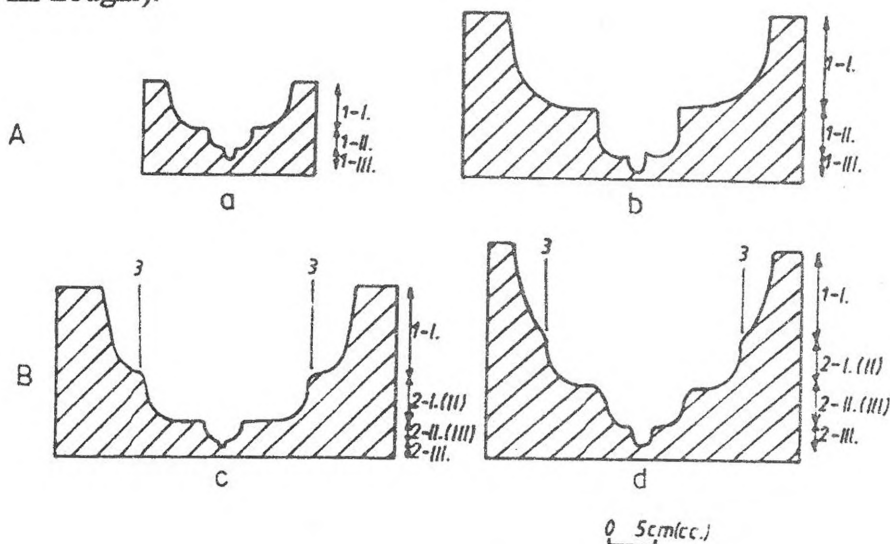

Fig. 11: Development of (a) terrace-less composite trough (b) and terraced (c, d) troughs
 Legend: A: the rate of growth of various troughs is similar, B: the master trough does not grow but the discharge decreases (c), or it grows but the discharge remains the same (d), 1: trough that developed before the growth (before terrace development) of the master trough, 2: trough developing after the growing of the master trough (in the period of terrace development) or trough changing to type II from type I, or to type II from type III. (the Roman numeral in the parenthesis indicates the type of the trough before terrace development), 3: terrace

The developing solution pot digests or bisects the karren troughs of the previous ground surface (trough beheading by solution pots). In this case the trough sections at the upper edge of the solution pot will recharge the pot while the others at the other side become inactive (hanging trough). The opposite may also happen, a growing karren trough can reach the edge of a solution pot and opens it up (solution pot made by beheading). In this case the pond in the solution pot is discharged to the beheading trough at low water and through the higher positioned trough as well in high water (Picture 11).

It may occur that two discharging troughs develop and one of them deepens at a bigger rate than the other. The one developing at lower rate becomes gradually inactive and becomes a hanging trough.

The temporary pond that develops in the solution pot is of varying size. At low water new, secondary solution pot(s) may develop at its bottom (composite solution pot). At the bottom of the composite solution pot terraces develop (Picture 5).

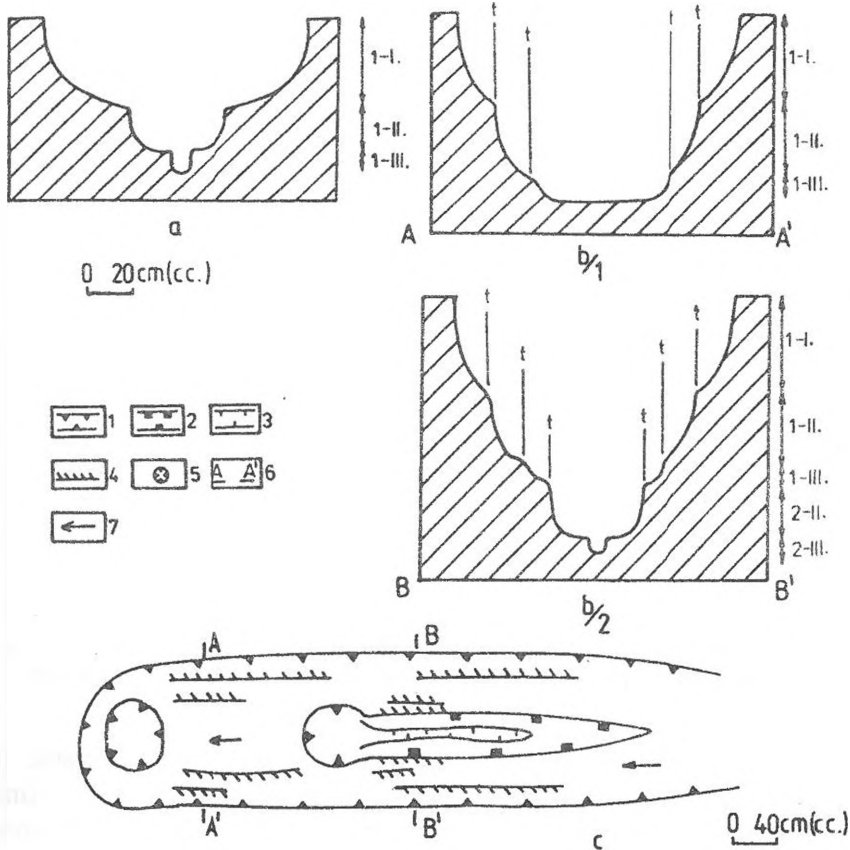

Fig 12: Terrace development in the case of piracy (after survey, sketch and photo)
Legend: a: stage of development before piracy, b: stage of development after piracy, b/1: inactive trough section after the second location of beheading, b/2: active trough section after the second location of beheading, c: plan, I, II, III trough types on the cross sections. 1: edge of the 1-I trough, 2: edge of the 2-II trough, 3: edge of the 2-III trough, 4: terrace, terrace remnant, 5: pit, 6: location of section on the plan, 7: slope of the trough-bottom.

3. Vertical Karren Development

In the course of vertical karren development solution takes effect from the surface towards the inside of the rock along fractures. The development of network karren (two direction solution), fracture karren (one direction solution) and pits. Pits may develop solitary or in groups (pit karren).

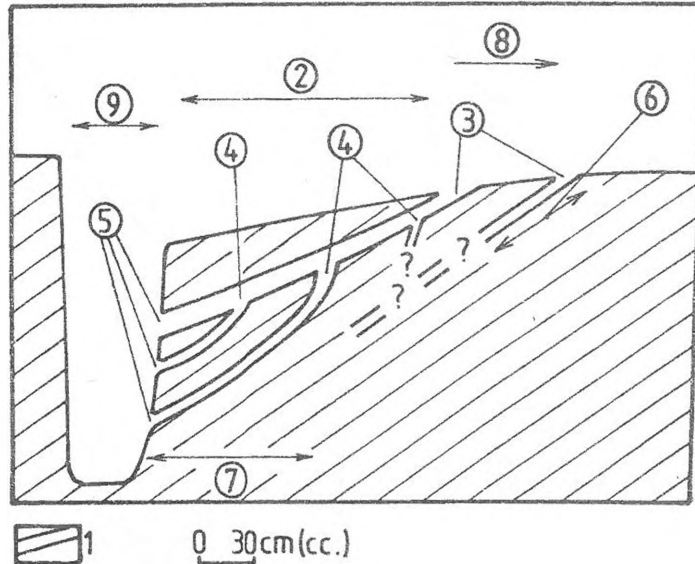

Fig. 13: Karren cavity system (observation)

Legend: 1: bedding plane, 2: through karren trough cavity, 3: karren trough swallet, 4: karren cavity swallet, 5: debouchure, 6: swallet type karren cavity, 7: spring karren trough cavity, 8: retreating of piracy, 9: fissure.

Solitary pits can develop outside (solitary pits) or inside of the troughs (trough-bottom pits). A type of trough-bottom pits (blind pit) develop at places where the troughs are crossed by fractures that have been developed to sizable solution fractures. These pits develop probably blindly (Picture 6), they may be filled with soil and vegetation. The other type of trough-bottom pits is of bigger diameter, they are not filled with soil and vegetation, they develop during the beheading of troughs (piracy pits). Trough-end pits (Picture 6) occur at the downstream end of the troughs and do not open on the trough-bottom but on the bank (they have their edge on the same elevation where the trough does). Their morphology is similar to that of the solitary pits (arched, concave side slopes that are dissected by

half-pits and solution runnels). Solitary pits show a transition towards the karstic meso-forms, the shafts.

4. Cavity- and Cave Development

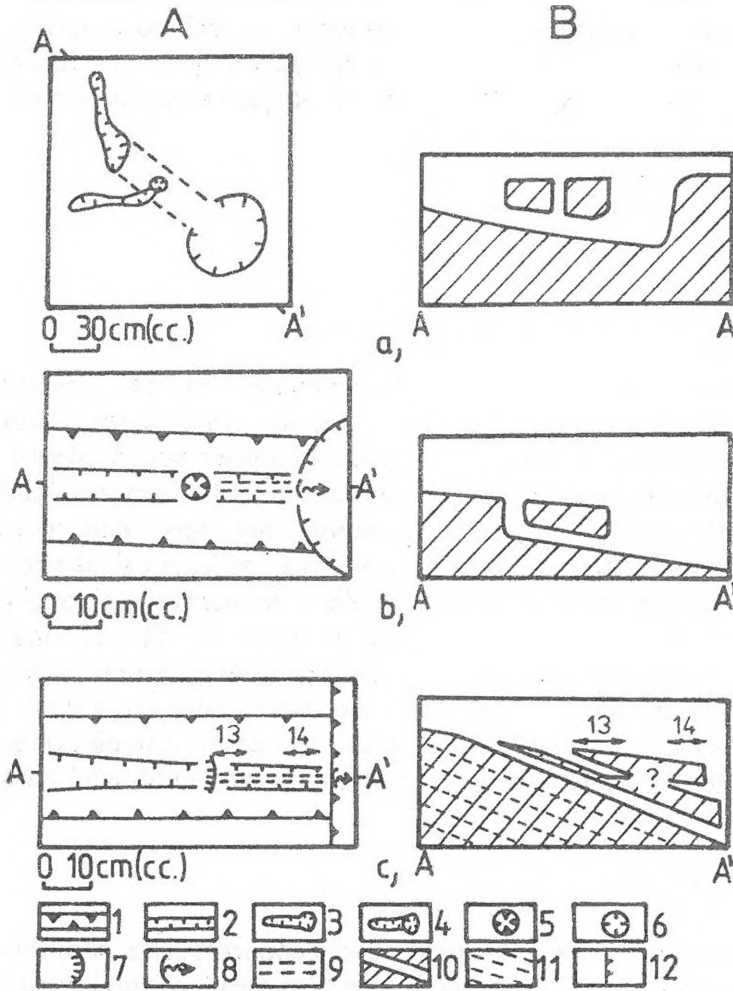

Fig. 14: Types of piracy (vertical beheading, after photos and sketches)

a: development of blind karren trough and secondary swallet when the karren trough is of the same age with the cavity, the development of the pit occurred after the cavity development; b: beheading of a type III trough by a pit. The development of the karren trough cavity occurred after the development of the trough; c: the beheading of a type III trough by a karren trough swallet cavity along a bedding plane.

Legend: A: plan, B: profile, 1: type I trough, 2: type III trough, 3: blind karren trough with karren cavity, 4: blind karren trough with pit, 5: karren trough swallet (pit), 6: solution pot, 7: karren trough swallet. 8: karren trough debouchure cavity, 9: cavity (plan), 10: cavity (profile), 11: bedding planes, 12: fracture, 13: swallet cavity, 14: debouchure cavity

Cavity development occurs along fractures or bedding planes. Subsurface solution can occur independently of the surface solution or in dependence with it. In the latter case a piracy (vertical beheading) occurs simultaneously with cavity development. Piracy is typical in epigene karstic valleys (JAKUCS, L. 1971, HEVESI, A. 1978). This phenomenon develops on the trough-bottoms too. Observations show that the location of the piracy is not invariable as in the case of the epigene valleys. The location of the beheading shifts to the upstream end of the trough (retreating of the location of piracy).

Cavities may develop:

- between karren depressions,
- under karren troughs.

4.1 Types of Karren Cavities

These cavities may be swallets (sinkhole), springs (resurgence) and through cavities (Picture 7, Fig. 13). Swallet type karren cavities may originate in solution pots (Picture 8) and in karren troughs. Spring cavities may open into pits, karren troughs, solution pots and fissures. Karren caves below karren troughs (karren trough cavity) may show delta development. Delta development starts in swallet cavities as an effect of the retreating of piracy. To spring cavities developing delta debouchures belong in various elevations in the sides of the fissures (Picture 9). The debouchures one below the other develop when spelean beheading occurs (karren cavity swallet). This process probably does not occur only in cavities under the karren troughs. It is possible that under the karren troughs (where cavity development occurs parallel to the bedding planes) multilevel karren trough cavity systems develop.

4.2 Types of Piracy

It may occur that the karren cavity connects such a solution pot and trough that are located on the same level. Upstream of the karren cavity the trough has no continuation (blind karren trough). The karren cavity is connected with the surface by a pit. The origin of this pit is subsequent solution in whole or in part or by cave in (collapse pit). The trough leading to this type of pit (blind karren trough with pit) developed by regression after the development of the pit (Fig. 14/a).

In case the karren troughs are beheaded (karren trough piracy) the trough can continue after the point of beheading (Fig. 14/b, Picture 7). The karren trough swallets develop at these points (pits by morphology). Karren

trough swallet cavity may develop at the point of the beheading e.g. if the solution occurs along a bedding plane, pitless swallet or through cavity develops (Fig. 14/c).

5. Merging Karren forms

The merging of karren forms can happen by solution or cave in. Merging by solution can happen between surface forms, or between surface and subsurface forms. In the latter case the merging may be promoted by cave in.

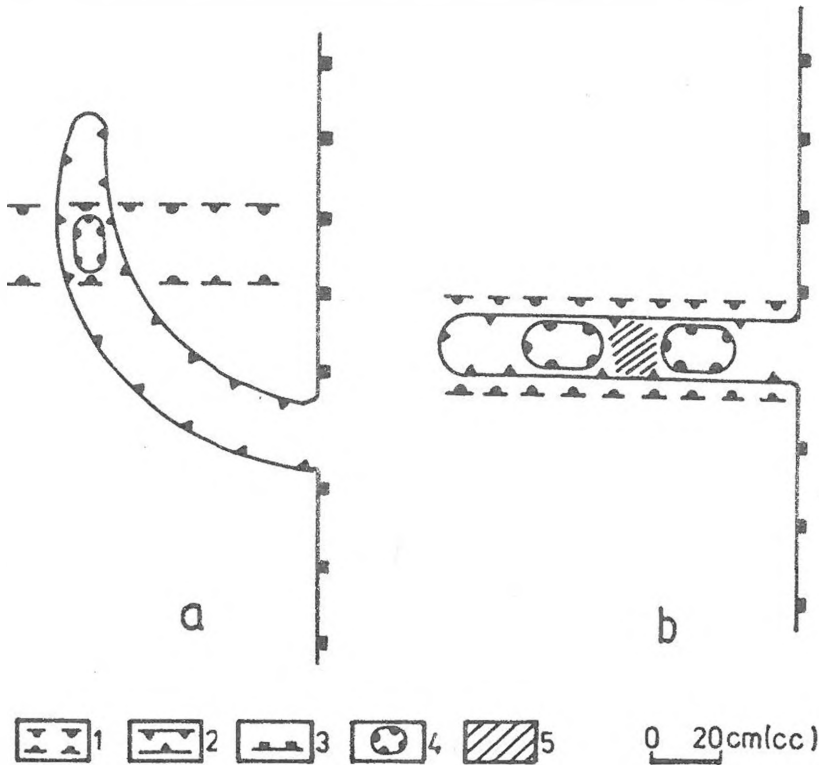

Fig. 15: Circular (a) and elongated (b) windows on karren cavity roofs
 Legend: 1: karren cavity, 2: type I trough, 3: solution fissure, 4: karren window, 5: karren bridge

5.1 Merging by Solution Between Surface Forms

Existing various karren forms may merge by lateral solution growth. It can occur between

- pit and pit (Picture 10),
- heel print and heel print,
- solution pot and solution pot (Picture 5),
- karren trough and karren trough.

The merging of similar surface forms (pit and pit, heel print and heel print, solution pot and solution pot) produces pit, heel print and solution pot uvalas (*Picture 11*). The merging of similar or different forms may result remnants (e.g. pit remnants or half-pits).

As a result of solution merging various forms, thin crests, edges, cones remain of the original surface. Some residual parts of the surface may retain the original elevation (karren inselberg).

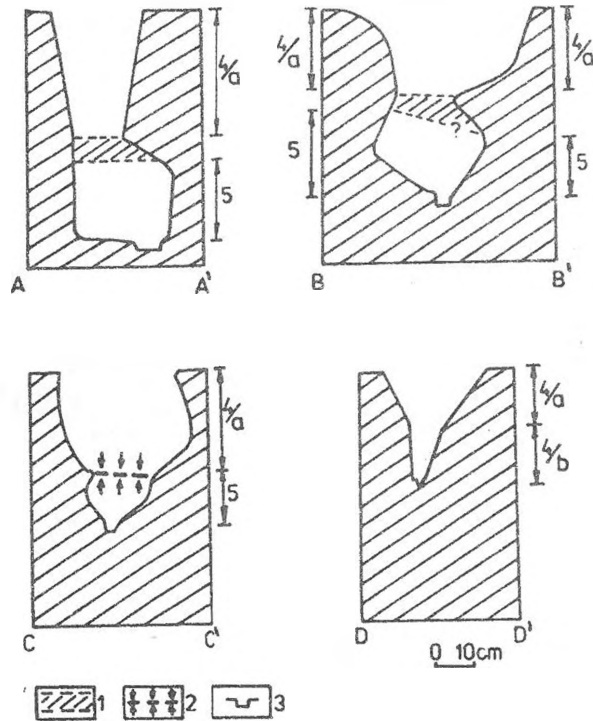

Fig 16: Characteristic cross sections of opened-up karren trough in various stages of development (survey)

Legend: 1: roof destroyed by cave in, 2: roof destroyed by the merging of trough and karren cavity, 3: type III trough, 4a: upper trough section developed by surface solution independently from piracy, 4b: lower trough section intensively developing due to beheading. 5: trough section developed by subsurface solution.

Comment: in the A-A' and B-B' cross sections the opening up happened by the cave in of the roof of the karren trough cavity; solution merging at C-C' section; piracy occurred between the C-C' and D-D' sections.

Different karren forms can merge during their solution growth. Most frequently combine troughs with heel prints, troughs with solution pots (*Picture 12*), pits with solution pots.

5.2 Merging by cave in

This process results the merging of a trough and the trough cavity below it (the opening up of the cavity). The karren cavity positioned below the troughs lose their roofs partly due to solution (that occurs from below upwards and from the surface downwards merging the karren trough and the karren trough cavity) partly to cave in. At the beginning of the process karren bridges and karren windows develop. The windows are circular if the karren trough traverses the karren cavity, elongated if the karren trough develops above the karren cavity in its whole length (Fig. 15). Troughs of characteristic cross section develop to the sink point of the earlier cavities (opened-up karren trough). This type is narrowing downwards then it is almost circular at the bottom. Remnants of the roof occur in the trough-sides (Fig. 16, Picture 13).

REFERENCES

- BALÁZS, D. (1980): Karrformák-karregyüttesek - Karszt és Barlang II. sz. pp. 117-126.
- BAUER, F. (1953): Verkastung und Bodenschwund im Dachsteingebiet - Mitteilungen der Höhlenkommission 1. f. p. 53-56.
- BÖGLI, A. (1976): Die Wichtigsten Karrenformen der Kalkalpen - In: Karst Processes and Relevant Landforms. ISU Commission on Karst Denudation. Ljubljana pp. 141-149.
- FRIDTJOF, B. (1954): Verkarstung und Bodenschwund im Dachsteingebiet - Mitteilungen der Höhlenkommission 1. p. 53-56.
- FORD, D. C.-WILLIAMS, P. W. (1989): Karst Geomorphology and Hydrology, Unwin Hyman, London
- HEVESI, A. (1978): A Bükk szerkezet- és felszínfejlődése - Földr. Ért. p. 169-203.
- JAKUCS, L. (1971): A karsztok morfogenetikája - Akadémiai Kiadó, Bp.
- JAKUCS, L. (1980): A karszt biológiai produktum - Földr. Közl. 28., 4. pp. 331-344.
- KUNAVER, J. (1984): The high mountains karst in the Slovene Alps - Geographica Yugoslavia 1983. Savez geografskih drustova Jugoslavije, Ljubljana p. 15-22.
- LECHNER, J. (1953): Neue Formen des Hochgebirgskarstes im Totes Gebirge - Mitteilungen der Höhlenkommission, pp. 47-49.

- MONROE, W.-WATSON, H.* (1972): A Glossary of Karst Terminology - US Geological Survey, Washington
- TRUDGILL, S.* (1985): Limestone Geomorphology - Longman, London and New York
- VERESS M.* (1992): A karsztosodás mikroformái a karrok - Természet Világa 3. pp. 129-131.
- VERESS M.* (1995): Karros folyamatok és formák rendszerezése Totes Gebirge-i példák alapján - Karsztfejlődés I. (Totes Gebirge karrjai) Pauz Kiadó, Szombathely p. 7-30.
- VERESS, M.-PÉNTEK, K.* (1992): Physical and Chemical Aspects of Hydrodynamics of Some Karstic Process. - New Perspectives in Hungarian Geography, Studies in Geography in Hungary 27, Akadémia Kiadó, Bp. pp. 91-104.
- VERESS, M.-PÉNTEK, K.* (1994): Néhány karsztos folyamat leírása fizikai-kémiai hidrodinamika alapján - Berzsenyi Dániel Tanárképző Főisk. Tud. Közl. IX. Természettudományok 4. pp. 145-172.
- WHITE, W. B.* (1988): Geomorphology and Hydrology of Karst Terrains - Oxford University Press, Oxford

List of pictures:

Picture 1: Composite trough (Totes Gebirge, Austria)

Legend: 1: type I trough, 2: type II trough, 3: type III trough (types II and III have forced meanders)

Picture 2: Free meandering type III trough in type I trough (Totes Gebirge)

Picture 3: Pectinated karren (Totes Gebirge)

Picture 4: Crest rock bridge (Totes Gebirge)

Picture 5: Partially merged solution pots (Totes Gebirge)

Legend: 1: terrace, 2: residual surface

Picture 6: Karren troughs developed on bedding plane with pits (Totes Gebirge)

Legend: 1: solution increased fracture, 2: trough-end pit, 3: blind pit

Picture 7: Through karren cavity (Totes Gebirge)

Legend: 1: type II trough, 2: type III trough, 3: karren trough swallet, 4: karren cavity, 5: opened up karren trough (karren cavity that lost its roof)

Picture 8: Karren cavity starting at solution pot (Totes Gebirge)

Legend: 1: solution pot, 2: karren cavity with damaged roof, 3: type II trough

Picture 9: Spring karren cavities (Totes Gebirge)

Legend: 1: upper spring cavities, 2: lower spring cavities (the two levels of the spring cavities proves beheading within the through cavity)

Picture 10: Merging pits (Totes Gebirge)

Legend: 1: gap caused by pit merging, 2: remnants of pits, 3: remnants of surface (partition walls between pits)

Picture 11: Solution pot uvala (Dachstein, Austria)

Picture 12: Solution pot opened by trough (Totes Gebirge)

Legend: 1: composite trough feeding solution pot, 2: trough discharging solution pot, 3: trough opening solution pot

Picture 13: Collapse karren trough developed by the partial collapse of roof

Legend: 1: trough section lacking roof, 2: existing roof, 3: remnant of rock bridge

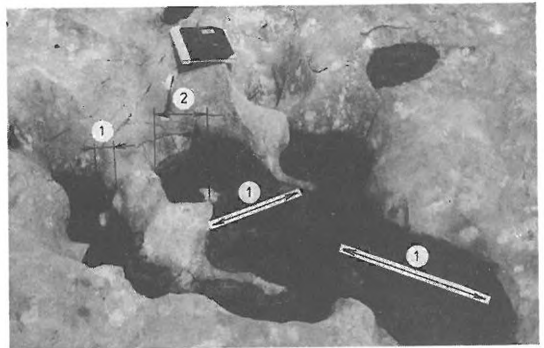
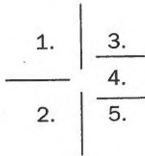
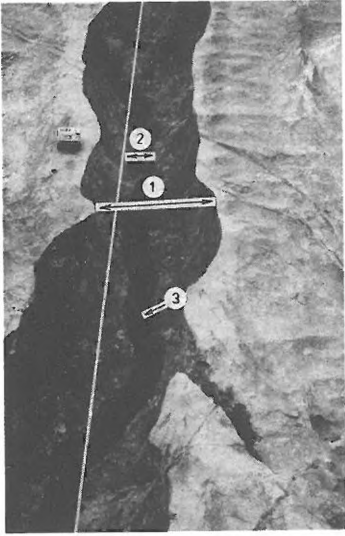

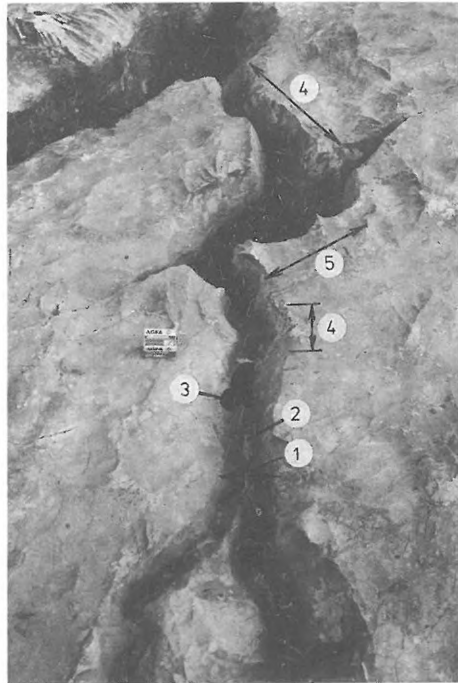

6. 7.
8. 9.

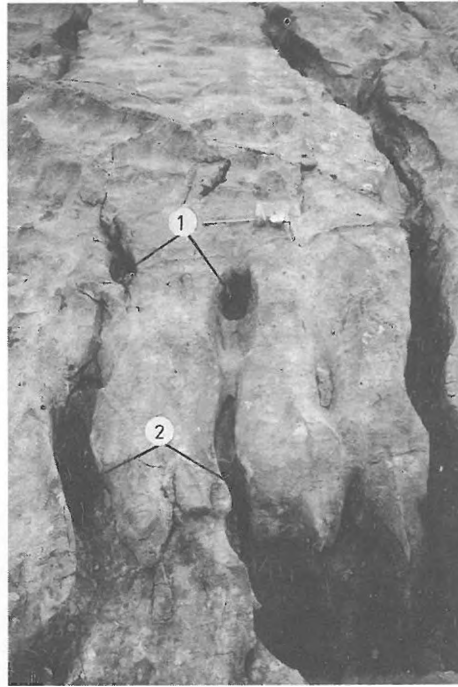
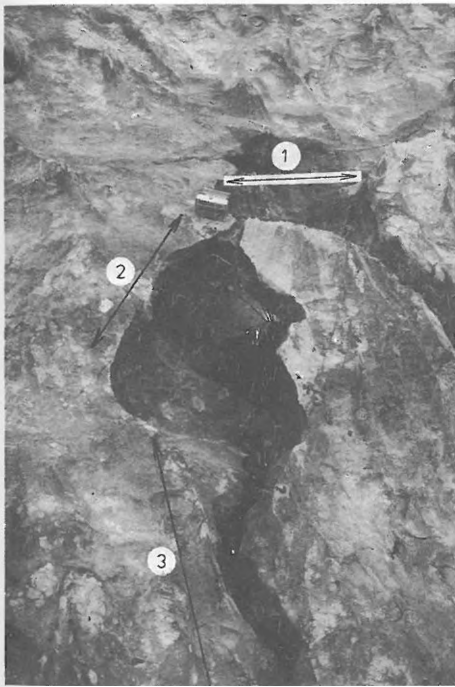

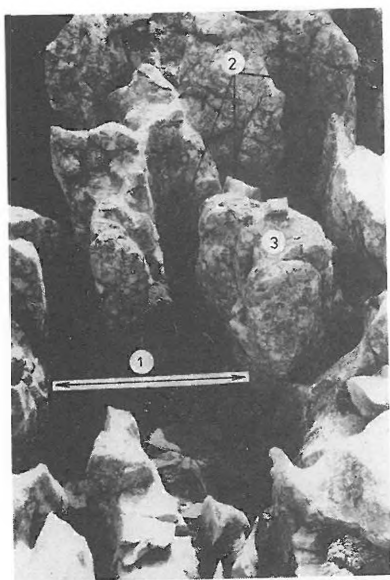

10. | 13.

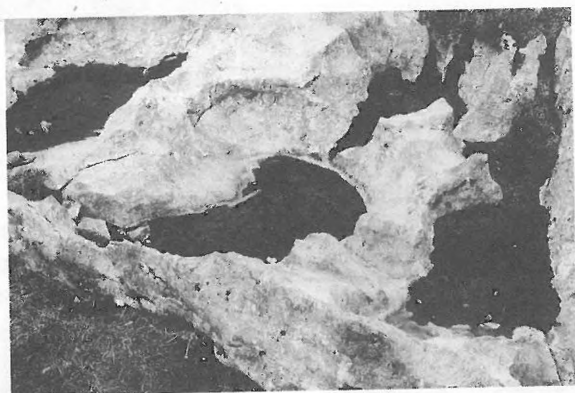
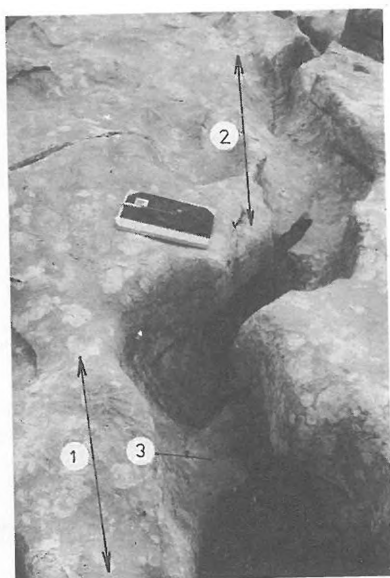

11.

12.

