

The Problem of Child Soldiers

DEÁK Gabriella¹

Today, child soldiers fight in a lot of armed conflicts around the world. They are often recruited through force or deception, and exposed to horrific violence. They may begin as messengers or porters, but too often end up on the front lines of combat. Some are forced to commit atrocities, and many girls are sexually exploited. They are denied an education and robbed of their childhood. Many do not survive.² I will deal with the question of child soldiers in my essay, looking into what causes can lead children to become members of regular or irregular armies and what kind of international regulations, actions may help to solve this problem.

Introduction

“This is a real crime against humanity. The child of war is lost of peace, lost in growth.” (Ann Veneman – uNICEF)³

The existence of child soldiers is not a new problem, but international public opinion (media, NGOs, public figures etc.) have dealt with this problem, for the most part, only after the Cold War and mostly in Western societies. Until now, the typical child soldier profile appeared, in popular consciousness, in connection with African countries, however, according to expert notions, around three hundred thousand children are taking part in more than 30 conflicts around the world. It is also perceivable, that in developing or third world countries there is a considerable number of children used in the armed forces. I am dealing with the question of child soldiers in my essay, explaining, firstly how baffling the definition of child soldiers is. Secondly I am looking into what causes can lead children to become members of regular or irregular armies and what kind of international regulations may help to solve this problem. Thirdly with the knowledge of the statistical data I will present solutions on how the international community should reintegrate these children into society and how to handle this international problem.

1. The child soldier concept

At the beginning of my essay, it is important to clarify the concept of child soldiers. Defining ‘child soldier’ is not an easy task. The two terms of the compound word contradict each other. A ‘child’ is a young, physically and mentally immature person, who needs special safeguards and care. In contrast, the term ‘soldier’ refers to adult men or women who have training and military preparation.⁴ uNICEF tried to formulate a definition of ‘child soldier’ in the Cape Town Declaration, which states:

“A child soldier is any person under 18 years of age who is part of any kind of regular or irregular armed force or armed group in any capacity, including but not limited to cooks, porters, messengers and anyone accompanying such groups, other than family members. The definition

1 Email: gabideak@yahoo.com

2 OrOMA et al. (2008) pp. 49–54.

3 Ann Veneman is the uNICEF executive director since 2007

4 COHN–GOODWIN–GILL (2003) p. 3.

includes girls recruited for sexual purposes and for forced marriage. It does not, therefore, only refer to a child who is carrying or has carried arms.”⁵

However, this concept is very broad and does not specify the circumstances under which a minor entered the army, or what role he or she has there, and it does not specify the role of girls in the armed forces, only their sexual exploitation is mentioned. When it comes to a definition of a ‘child soldier’, their age, the characteristics of armed groups, as well as the question of activity should be investigated. If examining age, we should note that, in many countries the age of 18 years is not a natural one for adulthood. The upper limit of childhood is variable in some societies and individual communities. In some countries, such as African countries, being a child is not age-related, but determined by their roles played in the community, and the undertaken responsibilities. In contrast, in Western societies, the age of 18 years is generally accepted. In many cultures, the age limit is set according to various stages of adolescence and young people must demonstrate that they are fit physically and emotionally for this role⁶. We can understand the concept of childhood only knowing cultural, historical and social factors.⁷

2. The number of child soldiers in the world

It is estimated that some 300.000 children - boys and girls under the age of 18 - are today involved in more than 30 conflicts worldwide. Although it is impossible to accurately calculate the number of children involved in armed forces and groups, it is clear that there are many tens of thousands of child soldiers.⁸ Child soldiers exist in all regions of the world

and, almost inevitably, wherever there is an armed conflict. Children are used as combatants, messengers, porters and cooks and for forced sexual services. Some are abducted or forcibly recruited; others are driven to join by poverty, abuse and discrimination, or to seek revenge for violence committed against them or their families.

The United Nations and other relief organizations make major efforts in order to gather reliable information on the enrolment of the child soldiers and on what impact armed conflicts have on children. According to The Global report 2008, (edited by UNICEF and the Child Soldiers Global Institution), between 2004 and 2007, there were children actively involved in armed conflict in government forces or non-state armed groups in 19 countries or territories. These were: Afghanistan, Burundi, Central African Republic, Chad, Colombia, Cote d'Ivoire, the Democratic Republic of the Congo (DRC), India, Iraq, Israel, and the Occupied Palestinian Territory, Myanmar, Nepal, Philippines, Somalia, Sri Lanka, Sudan, Thailand, and Uganda.⁹

Discussing the situation of girl soldiers needs a separate section. Girls continue to be involved in fighting forces, in combat and non-combat roles, in countries including Central African Republic, Chad, Nepal, Philippines, and Sri Lanka. Armed groups in Colombia, Cote d'Ivoire, the DRC, and Uganda. These locations were among those known to have subjected girl soldiers to rape and other forms of sexual violence. The country believed to have the largest number of child soldiers is

- 5 Cape Town Principles and Best Practices on the recruitment of Children into the Armed Forces and on Demobilization and Social reintegration of Child Soldiers in Africa (Cape Town, 27-30 April 1997). http://www.unicef.org/emerg/index_childsoldiers.html (12.12.2009.)
- 6 Arab societies, and in many countries in Africa.
- 7 ROSEN (2005)
- 8 BeSeNyő János: Néhány gondolat a gyerekkatonaságról. http://www.hm.gov.hu/hirek/kulfoldi_hirek/gyerekkatonasagrol (20.10.2009.)
- 9 Child soldiers Global report. 2008. <http://www.hrw.org/en/reports/2008/12/11/child-soldiers-global-report-2008> (12.12.2009.)

Myanmar (Burma), which has recruited tens of thousands of children into its national armed forces. The Global 2008 report also listed the organizations using such armed groups:

1. *Government*: Burundi, Democratic Republic of Congo, Guinea, Liberia, Myanmar, Sudan and Uganda
2. *Government supporters and paramilitary groups such as militias*: Colombia, Somalia, Sudan, Zimbabwe and Uganda
3. *Non-governmental armed groups* (these opposition forces, such as regional, insurgent, terrorist forces): Afghanistan, Chechnya, Colombia, Congo, India, Laos, Nepal, Nigeria, Sri Lanka, Sudan, Uganda and Yemen¹⁰.

The map (Figure 1.) shows the countries where children are recruited.

Children as young as 8 are being forced to fight in conflicts around the world, the United Nations and human rights groups report. Human Rights Watch lists 19 places where children were being used as soldiers in 2006. Click on highlighted places to learn more.

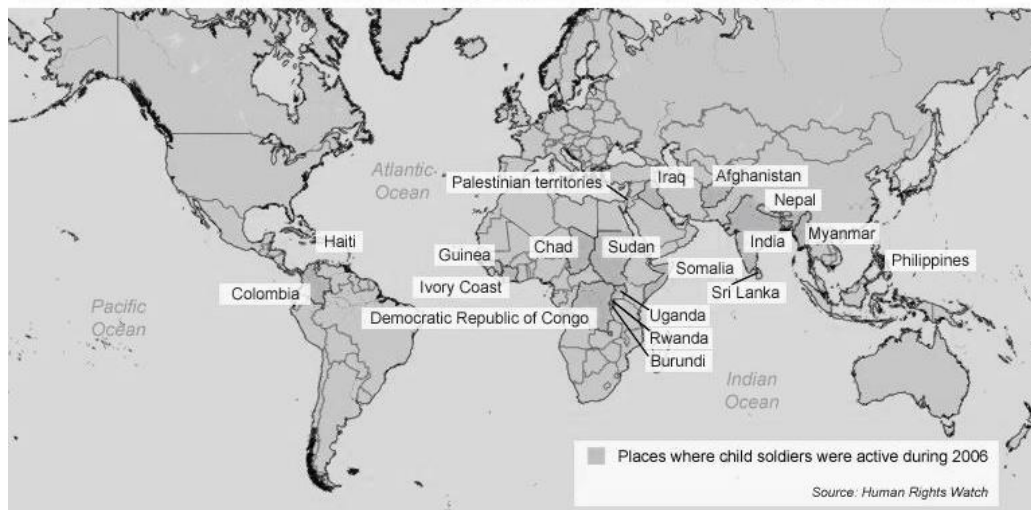

Figure 1. The map shows the countries recruiting child soldiers (2006 date)¹¹

2

3. The causes of child enrolment

“Child soldiers are ideal because they don't complain, they don't expect to be paid, and if you tell them to kill, they kill.”

Senior officer in the Chadian National Army (ANT)¹²

Some studies set apart three aspects of enrolment: with violence, mandatory and voluntary enrolment.¹³

1. **Enrolment with violence** is possible and beneficial for conscripted armed groups, because

10 Armed groups such as the Revolutionary Armed Forces of Colombia (FARC) and the National Liberation Army (ELN) in Colombia, the Liberation Tigers of Tamil Eelam (LTTE) in Sri Lanka, and the Lord's Resistance Army (LRA) in Uganda are well known for having recruited and used children over many years. Others receive less international attention. In southern Thailand the separatist group National Revolution Front-Coordinate (BRN-C) recruits under-18's (Child Soldiers Global report. 2008).

- 11 <http://www.hrw.org/en/reports/2008/12/11/child-soldiers-global-report-2008> (20.12.2009.)
 12 Voices of Child Soldiers. <http://www.childsoldiersglobalreport.org/content/voices-child-soldiers> (10.03.2010.)
 13 DCAF Backgrounder. Copii soldati. http://209.85.129.132/search?q=cache:BVVJDTDIBAJ:se2.dcaf.ch/serviceengine/FileContent%3FserviceID%3D21%26fileid%3D0C13B08D-AA8B-490A-227e-15676D7B2e64%26file%3Dro+Copii+soldati&cd=6&hl=hu&ct=clnk&gl=hu&lr=lang_ro (2009.10.10.)

these children :

- work for less money than adult soldiers;
- comply better with the instructions;
- are easy to deploy in combat and can easily be manipulated;
- survive easier in jungle fighting; have a small size, for mobility of deployable reconnaissance, espionage;
- generally do not represent a threat to the leaders, and are subservient;
- can cause problems of conscience for the enemy;
- can be easily persuaded to do illegal activities such as various types of contraband; or are easily converted into sex slaves;
- increase the number of armed groups, if the number of adult fighters is reduced (especially in protracted conflict).

2. Military duty, the legal obligation to join the armed groups. This can be included in the state laws related to the armed forces.

3. Voluntary enrolment or freely joining the armed forces. The children may have reasons to volunteer in the army:

- *Political and security reasons:* caused by violence in conflict situations, invasions, occupation of territories by governmental and non-governmental troops.
- *Economic and social reasons:* collapsed economy, poverty, lack of education, family, domestic violence, need for protection of the family, home loss, torture, discrimination against an individual or family etc. (Table 1.).
- *Cultural reasons:* the existence of values which exaggerate the importance of military life, or the influence of environment, the traditional military lifestyle of previous generations.
- *Ideological reasons,* an ideology of violence, to fight for a “true cause”.
- *Personal reasons:* access to benefits only from the military, education, money, rank occupied in society.¹⁴

Children are also affected by positive and negative experiences before and during wars. The environment and the experience of the child (social milieu) also affect the subjective decision. The environment, the parents, family, school, religion, and other community institutions, put pressure on or send messages to the children encouraging them to get involved in the fight. The child's attitude also influences the development of an objective relation to war.¹⁵

4. The problem of international control of child soldiers

The provisions of international law apply to children. These are the specific and comprehensive charters, such as human rights and international humanitarian rights, and international criminal law (Table 2.). Other sources can be the customary international and state law. Despite the fact that some states have not ratified international treaties, they can still be accountable for violation of customary international law. Children should be protected by national and international laws. The development of international legal standards between 1949–2007 are summarized in the table below. These international agreements, standards and regulations call for the protection of children. Violations of these can be charged to any member of the international community.

¹⁴ LOUYOT (2000) pp. 5–9.

¹⁵ COHN-GOODWIN-GILL (2003) p. 25.

Demand side	Supply side
<ul style="list-style-type: none"> • the rapid proliferation of cheap weapons • the armed organizations' objectives and activities (in conjunction with children and adults substitutability) • the armed organizations' capability (ideological belief, social base, organizational structure) • the armed organizations leaders' characteristics • the armed organizations' material base (the estimated amount of resources) 	<ul style="list-style-type: none"> • poverty • the education system's insufficiency • war environment, interaction between government and rebel groups • the refugee camps' openness; • religion, ethnicity • family (or orphanage) • impact of friendly community; • boredom • ideological grounds, belief • rural and isolated communities • the opportunity for access to land (through marriage or inheritance)

Table 1. Economic and social reason for child enrolment¹⁶

2007	The Paris Principles
10 May 2002	A World Fit For Children
6 Sept. 2000	United Nations Millennium Declaration
25 May 2000	CRC-Optional Protocol on Armed Conflict
25 May 2000	CRC-Optional Protocol on Exploitation
17 Jun. 1999	ILO Convention 182
12 Jul. 1998	Rome Statute of the International Criminal Court
25 Jun. 1993	Vienna Declaration and Programme of Action
11 July 1990	African Charter on the Rights and Welfare of the Child
20.Nov. 1989	The Convention on the Rights of the Child (CRC)
8 Jun. 1977	Geneva Convention-Additional Protocol I
8 Jun. 1977	Geneva Convention-Additional Protocol II
12 Aug. 1949	The Fourth Geneva Convention
10 Dec. 1948	Universal Declaration of Human Rights

Table 2. International Conventions¹⁷

4.1. The prosecution of child recruiters by the International Criminal Court (ICC)

“This first ICC trial makes it clear that the use of children in armed combat is a war crime that can and will be prosecuted at international level.” Para-Pree Singh¹⁸

The International Criminal Court Statute adopted in 1998 treats as a serious crime the infringements of the rules of non-international conflicts and the International Criminal Court has the authority and obligation to condemn those suspected, and declare those guilty of war crimes, who

16 Source: PARAGI (2008) p. 67.

17 Source: International law. <http://www.un.org/children/conflict/english/internationallaw.html> (10.03.2010.)

18 Counsel in Human Rights Watch's International Justice Program

enlist children into armies and send into battle those under 15 years of age. At the moment there are seven individuals wanted for such crimes with warrants already having been issued.

It is important to mention the Lubanga trial of the International Criminal Court because it is significant in many ways.¹⁹ This was the first ICC proceedings on the issue of child soldiers. This will help to create precedence in the ICC.

The ICC has situations under active investigation in four countries, Uganda, Democratic Republic of the Congo, Central African Republic, and the Darfur region of Sudan.

At the national level, there have been very few prosecutions of military commanders for the recruitment and use of child soldiers.²⁰

5. Handling the problem of child soldiery and finding solutions

Today there are 300 thousand child soldiers, and in spite of the existing international conventions their numbers are not declining. How could the problem of child soldiery be addressed? Some studies offer four methods of treatment: prevention, development of standards and their application, and the implementation of DDR programs (disarmament, demobilization, and reintegration).²¹ The DDR program for child soldiers should be implemented completely independently of adult program of DDR and more specific factors must be taken into account.

1. Disarmament: The collection of weapons in the conflict area. It is not always necessary to include this option in the program, because many children do not bear arms, especially girls, who do not always participate with weapons in battles, but serve a support function: provide food, nursing, etc.

2. Demobilization (Disarmament) is the official and controlled release of soldiers from the army.

However, for children it is more specific. It has to be investigated whether the child was involved in the conflict, but it is also necessary to establish the identity of the child, to find his or her family, the needs assessment must be conducted and prioritization has to be determined, and last but not least, sufficient information has to be obtained for reintegration.

3. Reintegration is a long process, which is designed to give children an alternative, saving them from the harm of armed conflict, and also helping them find their place in the community and in society again. Reintegration includes family reunification, or finding a new home for children, providing education and professional development, economic, financial aid, as well as creating a strategy that will help children to see themselves in the future, and to conduct an independent life. Reintegration could also involve providing mental assistance even with the help of a psychologist. The DDR program in

practice shows that its implementation should not be delayed until the end of the conflict, to be really successful. It should be started as soon as possible, before the conflict is over, as it was done with certain success in Colombia, Congo, Sri Lanka, Sierra Leone and Sudan.

However, besides the negative consequences mentioned above there could also be positive aspects of the involvement of children in conflicts. Perhaps the only way to stay alive is to join the armed forces.

-
- 19 The International Criminal Court Trial of Thomas Lubanga. http://www.hrw.org/en/news/2009/01/22/international-criminal-court-trial-thomas-lubanga#_Where_else_are (20.12.2009.)
- 20 Are there other cases where military commanders have been prosecuted or charged with recruiting or using child soldiers? http://www.hrw.org/en/news/2009/01/22/international-criminal-court-trial-thomas-lubanga#_Where_else_are (12.12.2009.)
- 21 DCAF Backgrounder. Copii soldati. http://209.85.129.132/search?q=cache:BVVJDTDIBA8J:se2.dcaf.ch/serviceengine/FileContent%3FserviceID%3D21%26fileid%3D0C13B08D-AA8B-490A-227e-15676D7B2e64%26lng%3Dro+Copii+soldati&cd=6&hl=hu&ct=clnk&gl=hu&lr=lang_ro (2009.10.10.)

Girls do not feel inferior to boys in the army, they are freer and stronger with weapons in their hands, and they feel they are on an equal footing with men. The army could provide orphans and street kids with a family of sorts, stability and a home. They learn discipline, loyalty, respect, a certain pride, at the same time they feel important, their self-confidence will increase, and they will think that their lives are in order, and enter into friendships.

This is not to say that it is a good thing to use child soldiers in armed conflicts, but every issue has a black and white side, too.

6. Conclusion

All conventions, standards, support programs, plans, laws, regulations and penalties are useless if the basic causes of the problem are not addressed and solved. Compliance to international law cannot at all times be expected from all states. Common law is not always observed, either. Economic inequality, overpopulation could always cause conflict. Poverty reduction and birth control could reduce conflicts. extensive assistance could make people passive; they would not, on their own, want to solve their problems, but would expect this from aid agencies. Mimicking, forcing, and offering the Western model on societies of developing countries might not lead to conflict prevention or a solution. Those societies that do not develop their own institutions can not emerge from underdevelopment and will remain conflict ridden. In community and tribe-based societies the exported Western democratic model can never be functional.

DDR programs has led to success in some countries, but I consider prevention more important than post-treatment of this problem. The international regulations and the DDR program have to attend the special needs of girls and would have to respond with particular rules. The further development of international legislation is very important, but such legislation should observe the sovereignty of states while aiming at the regulation of these specific internal conflicts.

Furthermore, another important issue still awaiting a solution is the question of under-aged mothers. Those girls who in childhood were abducted and raped in the camps during the conflicts later will have to take care of their children. Often their families do not accept them back, the soldiers' children are treated as enemies and therefore these young mothers and their children are very vulnerable.

From what we mentioned above we can draw the conclusion that the integration of children into communities is highly problematic. The said program could be considered a success if these people would be able to maintain a self supporting lifestyle, perhaps even learn a trade or a profession.

Another probable consequence of child soldiery might occur if a large enough portion of the society spent their childhood in war, then that society will necessarily reproduce all the conditions and circumstances that will keep human communities in a state of permanent disintegration and will result in a highly unsuccessful state. These societies can only imagine the possibility of changing the prevailing adverse conditions through the use of violence.

References

- Are there other cases where military commanders have been prosecuted or charged with recruiting or using child soldiers? http://www.hrw.org/en/news/2009/01/22/international-criminal-court-trial-thomas-lubanga#_Where_else_are (12.12.2009.)
- BeSeNyó János: *Néhány gondolat a gyerekkatonaságról*. http://www.hm.gov.hu/hirek/kulfoldi_hirek/gyerekkatonasagrol (20.10.2009.)

Cape Town Principles and Best Practices on the Recruitment of Children into the Armed Forces and on Demobilization and Social Reintegration of Child Soldiers in Africa (Cape Town, 27-30 April 1997). http://www.unicef.org/emerg/index_childsoldiers.html (12.12.2009.)

Child soldiers Global report. 2008. <http://www.hrw.org/en/reports/2008/12/11/child-soldiers-global-report-2008> (12.12.2009.)

COHN, Ilene – GOODWIN-GILL, Guy S. (2003): *Child Soldiers. The Role of Children in Armed Conflict*. A study for the Henry Dunant Institute Geneva, Clarendon Press, Oxford.

DCAF Backgrounder. Copii soldati. <http://209.85.129.132/search?q=cache:BVVJDTDIBA8J:se2>.

- dcaf.ch/serviceengine/FileContent%3FserviceID%3D21%26fileid%3D0C13B08D-AA8B-490A-227E-15676D7B2E64%26lng%3Dro+Copii+soldati&cd=6&hl=hu&ct=clnk&gl=hu&lr=lang_ro (2009.10.10.)
- International law*. <http://www.un.org/children/conflict/english/internationallaw.html> (10.03.2010.)
- LOUYOT, Alain (2000): *Gyermekek fegyverben*. Pont Kiadó, Budapest.
- OROMA Fiona et al. (2008): *A háború gyermekei. Gyermekanyák és gyermekkatonák a Nagy Tavak vidékén*. Afribook Kiadó, Budapest.
- PARAGI Beáta (2008): Gyerekkatonák Afrikában. In: *Külügyi Szemle*. Budapest. 2008. tél.
- ROSEN, David (2005): *Armies of the Young Child Soldiers in War and Terrorism*. Rutgers University Press. New Brunswick, New Jersey, and London. <https://doi.org/10.36019/9780813537832>
- The International Criminal Court Trial of Thomas Lubanga*. http://www.hrw.org/en/news/2009/01/22/international-criminal-court-trial-thomas-lubanga#_Where_else_are (20.12.2009.)
- Voices of Child Soldiers*. <http://www.childsoldiersglobalreport.org/content/voices-child-soldiers> (10.03.2010.)

The Radio Controlled Improvised Explosive Device (RCIED) threat in Afghanistan

GuLyÁS Attila

The Radio Controlled Improvised Explosive Devices (RCIED) are one of the most significant IED-threats in the region of southern Afghanistan. Since I began my military service in ISAF I have recognized that the occurrence of RCIED threats have been increasing continuously since 2008. My survey will provide a short overlook of these types of threats, furthermore my aim is to show the common manner of RCIED's frequency-use and the insurgent's "favourite" devices and bandwidths (frequency-bands) to help avoid serious damage to the Hungarian military servicemen, vehicles and military compounds in the theatre. I am sure that the knowledge of commonly used RCIED-types will help to the Hungarian Special Operations Forces units (HUNSOTUs) to learn the insurgent's (Taliban) tactics, techniques and procedures and overpass many of their IED-systems.

Introduction

The radio Controlled Improvised Explosive Devices' (rCIED) threat in Afghanistan has changed little technically since late 2006. In 2008 Afghanistan experienced more than 4,000 Improvised Explosive Device (IED) attacks, it means more than double that of 2007.¹ Afghanistan is the country where IED employments are systematically used. Facing this threat, the coalition members are trying to improve the protection of their soldiers and to act against the devices.² These human and financial investments are focusing on a technological answer and the deployment of new capabilities. However, despite these efforts IEDs remain efficient and NATO and Afghan National Security Forces (ANSF) losses have never been so high. Indeed, the IEDs are implemented in very simple ways and tested by technological processes, in a rustic style just the opposite of NATO technological answers.³

The majority of radio Controlled IEDs continue to use purpose-made Dual-Tone Multi-Frequency (DTMF) VHF systems (commonly referred to as "spider" devices). The south provinces (near Pakistan's border) such as Nimroz, Helmand, Kandahar, Zabul, Paktika, Uruzgan, and Farah are the most dangerous territories, in regards to rCIED threats. E.g. rCIED incidents in Helmand Province account for 10-15%⁴ of the IED threat. The Victim-Operated IEDs (Pressure Plates) account for almost all of the remainder. It is judged that any change in the use of ECM which remove coverage on known rCIED frequencies would likely be exploited by Enemy Forces (EF). The presence of rCIEDs can not be discounted in areas where other types of IED (e.g. Victim-Operated Pressure Plate) are assessed to be the most prevalent threat. It is judged that the spread of personal mobile communications networks into new areas offers the greatest potential for the development

1 report on Progress Toward Security and Stability in Afghanistan (2010). p. 54.

2 DOCTRINE General Military review, editions of 2009-2010

3 DINGLEY (2009) p. 104.

4 GrAHAM (2011) p. 137.

of the rCIED threat in those areas.

This survey is based on my personal experience and the overall defence intelligence systems' reporting and information sharing. These provide source assessments, which draw on the range of available sources including intelligence reporting, military intelligence collection, imagery, diplomatic reporting and other open source materials (Internet).

The technical and historical evidence are strongly based on reporting from the theatre and exploitation of recovered equipment, in my experience. Technical and engineering principles concerning the manufacture of IEDs, some of which are based on other theatres of operations, are also used. The assessment of future IED trends and evolution of types is based on the statistical analysis, the interpretation of enemy forces' trends and modus operandi, previous technical evolution, known technical limitations of enemy forces, their dispositions and the processes for countering threats.

My rCIED assessment of the threat in Afghanistan is in accordance with the requirement to make the readers understand the formation of several defence policies and the commitment of the Armed Forces and includes the commonly used rCIED jammers' types and bandwidths.

What is the RCIED threat?

The effectiveness of Coalition Force (CF) electronic countermeasures (ECM) in Afghanistan is a prime factor in the continued relative reduction of the rCIED threat. Since late 2006, Enemy Forces (eF) have used essentially the same types of RCIED firing switches. Different versions of the spider family of VHF receivers (DTMF) are used for telecommunications signalling over analogue telephone lines in the voice-frequency band between telephone handsets

Gulyás Attila: The Radio Controlled Improvised Explosive Device (RCIED) threat in Afghanistan and other communications devices and the switching centre⁵ have all been seen, but to date, their operating parameters have remained broadly consistent with earlier models. The spread of mobile communications networks such as GSM mobile phone and Code Division Multiple Access (CDMA) local loop services, which are already established in the larger population centres in Afghanistan, continues. Infrastructure is presently centred on population centres and the main route (Highway 1). [3] The wireless telecommunications market has been growing continuously since 2002 and will likely continue to do so for the foreseeable future. As of January 2009 the 4 licensed GSM providers in Afghanistan had 7.2 million subscribers. In addition, several companies have been allowed to operate networks using the uS 3G standard (CDMA 2000)⁶. GSM providers will continue to roll out more capability and continue to expand network coverage across Afghanistan. The increasing availability of mobile personal communications makes it more likely that EF will make greater use of the systems in rCIEDs. Figure 01 shows the occurrence of rCIED among all of the C-IED threats⁷ in South Afghanistan in 2009. Mobile phone networks already operate in the main population centres of Helmand province (in Kajaki, Gereshk, Lashkar Gah, Musa Qal'eI and Sangin).

5 SCHENKER L. (1960) pp. 235–255.

6 GROSS-SANGIN (2008)

7 DOCTRINE Military review: Regional Command-Capital survey 2009, edition of 17/2009. pp. 37–40.

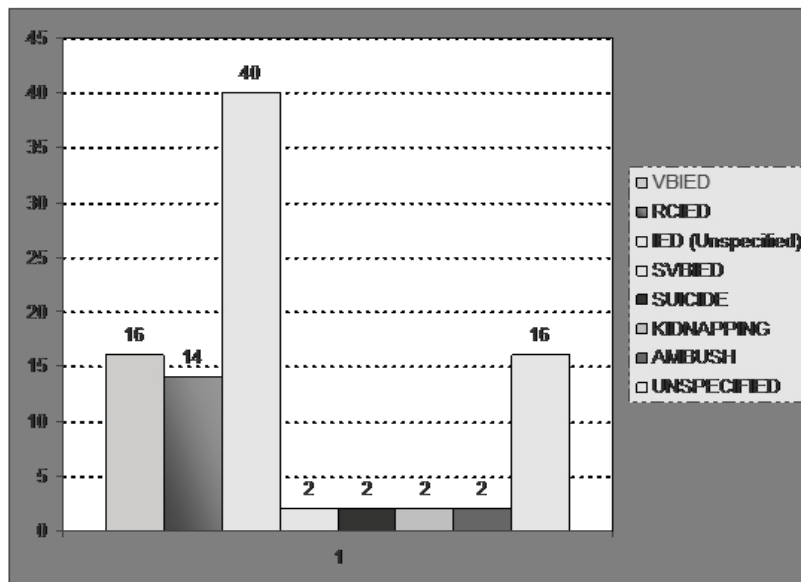

Figure 1.

Definitions

For a better understanding of what the acronym IED (rCIED) means it is necessary to specify the expressions regarding the improvised explosive devices' issues.

Improvised Explosive Device (IED): A device placed or fabricated in an improvised manner incorporating destructive, lethal, noxious, pyrotechnic, or incendiary chemicals and designed to destroy, incapacitate, harass, or distract. It may incorporate military stores, but is normally devised from non-military components. All IED-related definitions will default to the Weapon Intelligence Team's IED Lexicon⁸.

1. VEHICLE-BORNE IED (VBIED): An IED delivered by any small ground-based vehicle (e.g. passenger vehicle, motorcycle, moped, bicycle, etc.) and/or serves as the concealment means for explosives with an initiating device.
 - Bicycle
 - Large Truck (Jingle/Tanker)
 - Small Truck (Pick up)
 - Car
 - Motorcycle
 - Other
 - SuV

2. **Suicide VBIED (SVBIED):** A VBIED whose explosives are intentionally initiated by the vehicle's occupant.

- Bicycle
- Car
- Cart
- Motorcycle
- SUV
- Large Truck (Jingle/Tanker)
- Small Truck (Pick up)
- Other

3. **RCIED:** An IED initiated electronically in a wireless manner consisting of a transmitter and receiver (i.e. personal mobile radio (PMR), cell phone, cordless phone, pager, etc)

- RC Cell phone
- RC DTMF
- RC DTMF (Mod unknown)
- RC Vehicle Alarm
- RC Other
- unknown

4. **COMMAND IED:** Initiated with a wire and power source, may include a switch

- Command Pull (Mechanical)
- Command Wire (Electric)
- Command Other
- unknown

Threat priorities

Figure 2. shows the breakdown by type of known RCIED incidents since the start of 2009⁹. The spider family of devices accounts for approximately 75% of the RCIED threat, with various types of radio systems making up the balance. The commonly used frequencies are in the VHF band. It is because the electronic devices using this frequency-band are sold in every cheap market and it is not complicated to buy-assemble-install-operate the explosive devices mounted to RCIED.

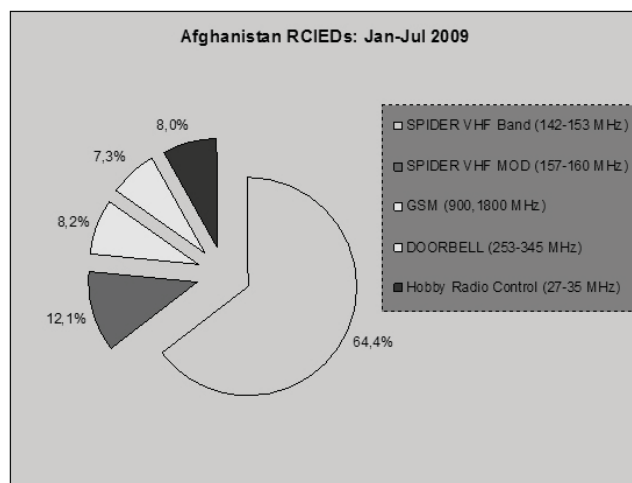

Figure 2.

8 Standard Insurgent Action Terms - ISAF SOF FRAGO080705 pp.18-21.

9 BARKER (2010) p. 5.
AARMS (12) I (2013)

The hobby radio control devices operate in high frequencies (HF). It is difficult to build a spread jammer spectrum-device against them. The commercial (Commerce Off The Shelf COTF) and few military jammers, mostly, do not jam under 30 MHz, so the RCIED operated in that frequency range could be extremely efficient and lethal.

The most common spider devices operate in the 142-153 MHz frequency range. In the free market of South Afghanistan anybody can purchase simple devices working in these ranges, the types of the devices are listed in the Tables of this survey. The Taliban mostly use the handy radios (ICOM, Kenwood) for this simple reason.

Figure 03 shows the breakdown, by type, of known RCIED incidents in Helmand Province since the start of 2009. The

Gulyás Attila: The Radio Controlled Improvised Explosive Device (RCIED) threat in Afghanistan spider family of devices accounts for approximately 84% of the rCIED threat, with various types of radio systems making up the balance. [4]

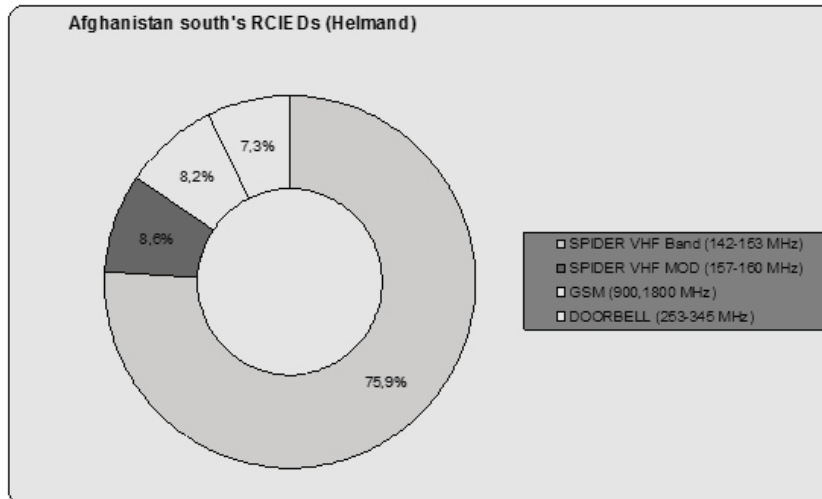

Figure 3.

In Helmand Province, rCIED incidents continue to account for 10-15% of the known IED threat. rCIED attacks are largely directed at CF but achieve the most success against ANSF when they are not protected by CF ECM. E.g. one of the successful rCIED attacks in June 2009 resulted in the death of an ANA officer. A CF (UK) KIA occurring in an RCIED attack was in September 2007 and one WIA in March 2008¹⁰. It is assessed that the relatively low number of CF casualties from rCIEDs is directly attributable to the effectiveness of CF ECM. It is judged that any change in the use of CF ECM which removed coverage on known rCIED frequencies would likely be exploited by EF.

Threats in South Afghanistan

The RCIED threat in Afghanistan varies significantly by province. The assessed RCIED threat priorities, in decreasing order of priority, for areas in the south are:

¹⁰ BARKEr (2010) p. 7.

a) Regional Command (South):

1. Bespoke DTMF-encoded VHF systems (includes purpose-built devices, e.g. Spider variants and Sega, transceivers e.g. ICOM, Kenwood, Motorola - 136 to 174 MHz).
2. Bespoke key-fob switcher - 315 MHz.
3. COTS transceivers GMRS - 462 to 468 MHz.
4. GSM-based systems - 900 and 1800 MHz. (where infrastructure is available)
5. remote Switch – Purpose Built Transceiver (the Wireless Custom receiver (WiCr)) - 869 MHz.
6. COTS Transceivers - 409 MHz.
7. HPCP systems (normally Handset to Base Station) - majority 225 to 232 MHz.
8. Other rC systems seen to date are in very low numbers. Individual systems - such as door-bells, car alarm systems, rC toy and appliance controllers have been seen less than 4 times across Afghanistan since 2002. [5]

AARMS (12) 1 (2013)

b) Capital Region:

1. Bespoke DTMF-encoded VHF systems - 136 to 174 MHz.
2. Bespoke key-fob switcher - 315 MHz.
3. GSM-based systems - 900 and 1800 MHz.
4. COTS Transceivers GMRS - 462 to 468 MHz.
5. remote Switch – Purpose Built Transceiver (WiCr) - 869 MHz
6. Telemetry systems - 418 MHz.
7. HPCP systems (normally Handset to Base Station) - majority 225 to 232 MHz.
8. Other rC systems seen to date are in very low numbers.

My detailed list of known threat frequencies is based on in-theatre reporting and technical exploitation. The value of technical exploitation in the identification of new threats cannot be overstated, but does rely on the timely recovery of intact

devices. It can be concluded that the most often used frequencies are in the frequency range of VHF/UHF and the mobile phone band. In the south part of the country the civilian merchants provide a great selection of electronic devices used in the civilian sector of industry and commerce. These electronic devices are operated in the free (not secured) frequency ranges and are easily purchased. This fact broadens the opportunities for the IODs' constructors to make easier and more low-profile RCIED devices, and find the cheapest and the most efficient (laziest) way to buy and fit these devices together. Another problem to re- solve is that these cheap electronic devices using the VHF frequency range are very simple built-in constructions. For this reason the daily-weekly-monthly maintenance and the repairing cycles, im- portant to keep them in working order, are a simple-manner, understandable, and easily learnt. The proof position of coalition forces increases with the national jammers, operated by ISAF troops in the field. All of these provide higher security and all-round defence for national/international troops of ISAF against spider devices and other types of threats. These provide a higher level of power-output for jammers giving the troops higher levels of convoy velocity and beyond this op- erational capability.

The passive infrared (PIR) firing switch

The PIR firing switch is not classified as an RC threat (the value of technical exploitation in the identification of new threats cannot be overstated, but does rely on the timely recovery of intact devices) but is directly associated with RC arming systems. The PIR firing switch has been known to have been used in an IED attack in Afghanistan just once (21 April, 2007). Intelligence agencies

continue to monitor this threat, but judges that its further use is not imminent. It is assessed that the PIR threat should be allocated the same priority as the associated RC arming switch (currently the LINX 418 MHz telemetry module). The PIR firing switch is victim operated rather than radio controlled.

Jamming

All coalition troops have their own jamming system to avoid serious damage to their own forces using those in vehicles and manpack-series. As we have seen in the figures, the VHF/UHF band and the mobile phone band are the most dangerous frequency ranges used by the spider family.

Coalition troops in theatre use several types of vehicle-born jammer devices and tactical man- pack sets. These are mostly COTF devices and provide overall defence against EF's RCIEDs. One of the used types of vehicle-born tactical jammer units is the wide band systems - WBS¹¹ (Figure 04). The set is a compact, multi-channel, programmable active jammer, operating over the 25 to 2500 MHz frequency range. The operating range covers the surveyed radio spectrum between these two extremes allowing the selection of channels with no gaps or blind spots. It can be repro- grammed in the field using a laptop or PDA running a MS Windows operating system to change its jamming waveforms, target frequencies and operating parameters. Settings are stored in non-vol- atile memory and activated automatically whenever the equipment is switched on. Mission data and operating firmware can be rapidly cleared via a button sequence on the front panel or Remote Control unit (RCU) keypad. Division Multiplexing (TDM) technology is used enabling the unit to be programmed for a variety of operational requirements¹². The user-friendly panel interface allows field-based operators to rapidly interchange between missions and cater for a variety of strategic and tactical scenarios. each unit has one fixed RF jamming channel operating over the 25 to 220 MHz frequency range (VHF/UHF frequency range), in addition to five user-definable 150 MHz jamming channels which can be steered to any part of the 25 to 2500 MHz frequency range as required. To eliminate the need for complex cabling configurations the unit contains two integrated power amplifiers (10-100W).

AARMS (12) 1 (2)



15

Figure 4.

11 Asian Mil Review: Blocking the trigger – IED/ECM Technology Update, 03 May 2008, pp. 36-39.



Figure 5.



Figure 6.

The rackmount unit (Figure 5.) is an advanced man portable battery-powered programmable ECM system focused primarily at counter-RCIED and Force Protection applications. It is fully field-programmable and allows new mission parameters and waveforms to be easily loaded into the unit from a laptop PC.

It is available in two variants:

- for operation in the 25-512MHz frequency range;
- for operation in the GSM900, GSM1800 and GSM1900 bands.

Both versions can generate transmit RF powers up to 10W. The set contains a versatile transmitter module, capable of generating up to 10W RF, coupled to a high-speed direct digital synthesizer (DDS) and digital signal processor (DSP) that are capable of generating a wide range of different jamming signals. The operating firmware and operational configuration of a jammer set can be field-reprogrammed and upgraded easily to respond to changing targets, priorities and techniques (Figure 6.). The set is designed primarily for man-portable applications and is typically carried in a special ECM backpack¹³.

Summary and deductions

The favorable areas of attack are known; the targets, even if it is too difficult to get close to them, remain easily identifiable. The look for added value remains a constant, either aiming at tactical objectives by destroying the main threat, the C2 means or limited assets, or aiming at strategic objectives by striking facilities, VIPs or symbolic targets, and seeking psychological effect. These new assets, despite a costly development offer, for most of them, are only a partial answer to the problem. Moreover, they create important training needs, both learning how they work and integrating their tactical use. Taking this protection and its limits into account and in the scope of a relationship of the weak to the strong, the insurgents are keeping very simple operating modes without taking part in this technological logic. Despite some complex IEDs having already been used, it seems that homemade systems remain predominant. Thus, in reply to jammers being wide- spread, the insurgents use, more traditional assets in which mechanics overrides electronics. This trend explains the significant decrease of radio controlled systems and the renewal of pressure or wire systems even if they impose longer laying time. In the same way, facing a longer range and an improved capability of returning fire, he favors either the remote control of the launch unit at several hundred meters from the target or the combination of several ignition systems. These methods enable him to select the target without any collateral damage. [6]

The rCIED threat will continue to account for a sizeable proportion of IED incidents across Afghanistan. EF monitors CF use of ECM and retains the capability and intent to exploit weaknesses and gaps in coverage and associated TTPs. It is judged that any change in the use of CF ECM which removed coverage on known rCIED frequencies would likely be exploited by EF. Table 01-07 show the occurrence of rCIED's device types and their frequencies and the threat they cause in the frequency spectrum of VHF. In addition, the presence of rCIEDs in the immediate area of other types of IED, e.g. Victim-Operated Pressure Plate, cannot be discounted. EF continues to seek fresh and updated rC technologies and techniques in their efforts to overcome CF ECM and associated procedures. Although there have been no technical changes in the rCIED threat in the last months of 2009, it should not be assumed that this will remain the case.

13 Tactical Manpack Unit descriptions, Jane's Explosive Ordnance Disposal, 28 February 2011, pp. 50-52.

Deductions

1. The spider device threats, using the VHF frequency range (140-160 MHz) are spreading. The basis of rCIEDs (electronic devices, electronic parts of devices) can be bought in the free market (COTF) so the assembling and the mounting of these devices are easy and well-known by insurgents. The all-round defence against these electronic devices could be the rigid control of merchandising, in regards to the devices operating in these frequency ranges.
2. In the programming phase of jammers the ISAF needs significant care of the frequencies using the spider (VHF) assets. The higher the power jammers' output, the higher the level of secure movements and operations. The average cover distance of national and international (ISAF) assets are 10-15 meters according to my personal experience. It would be beneficial if troops could broaden the cover-area to 20-30 meters or more, augmenting the all-round defence of convoys and dismounted troops. It could be possible with higher power output of vehicle and manpack jammers (versions detailed above). However the higher power results in higher measures and weight of assets, so it might only be realistic in the case of armoured personnel carriers (APCs).
3. It is necessary to provide great attention to the frequencies used by spider devices and to the all-round defence protecting our forces. If the 45 countries composing the ISAF provide a higher interest in operations planning against rCIEDs use the knowledge of spider frequencies and jammer capability, there might be efficient and reliable methods to better protect ISAF troops.
4. The electronic devices using the GSM range are electronically jammed by ISAF jammers. It could be distracting in the case of ISAF communication channels programming. Browsing through the operation system of the jammers, it is possible to install program gaps into these ranges. However, this is not the way the ISAF may move in the near future. My personal opinion of what the ISAF has to do is to use the frequencies not covered by coalition jammers. Turning off the jammers or not using their programming for these GSM frequencies (programming gaps into the jammers' band) cause serious harm (danger) to ISAF troops, because in this case the EF could also use their devices in an easy way.

AARMS

(12)1 (2013)

17

I believe, and it seems very clear, that mobile communications networks will continue to expand in Afghanistan. Experience shows that where this type of communications is available it is consistently used by EF in rCIEDs. As infrastructure spreads, it is judged that EF will make greater use of the systems in rCIEDs. Taking into consideration the most commonly used frequencies and the types of devices using these frequencies, we can build an overall jamming defence based upon the direct instructions of the theatre intelligence sources and practical experiences of our own. From the following tables we can examine and understand the commonly used devices and their frequencies, preparing our troops by properly tuning their jammers to avoid the rCIED threat all over Afghanistan.

In concluding my survey, I will provide a few tables to summarize the commonly used devices by insurgents and the frequencies involved in their operations (Table 1-5.. Figure 7-8.).

Serial	Threat configuration		Operating freq. (TX)	Modulation coding/schemes	Typical transmit	Typical link range	Comments
	receiver	transmitter					
Remote Switch – Keyless Entry System							
1	Keyless entry rX	-	306.2 to 313.33 MHz	-	-	≤ 100 m	Keyless entry system, most likely car alarm
Remote Switch – Car/Motorcycle alarm							
2	Car/Motorcycle alarm rX	-	~ 314 to 316 MHz	-	-	≤ 100 m	Steel Mate product
		-	~ 315 MHz	-	-	≤ 100 m	Mitsuba & Little Flying Tiger products
Remote Switch – Wireless Doorbells							
3	Doorbell rX	Doorbell switch	~ 253.14 – 345.5 MHz	-	-	≤ 100 m	All types
			253.14 263.5 MHz	-	-	≤ 100 m	Artslon TX product
			301.6 MHz	-	-	≤ 100 m	

Table 1. Threat frequency table (as of JUN 2010)

Serial	Threat configuration		Operating freq. (TX)	Modulation coding/schemes	Typical transmit	Typical link range	Comments
	receiver	transmitter					
Remote Switch – Wireless Doorbells							
3	Doorbell rX	Doorbell switch	~ 308 – 311 MHz	-	-	≤ 100 m	rL Type product (Chinese)
			314.705 MHz	-	-	≤ 100 m	CST TX product
			316 to 318 MHz	-	-	≤ 100 m	Consta NS-2000
Remote Switch – Purpose built devices							
4	PC game controller (SEGA)	ICOM IC-V68 KENWOOD or similar transceiver Bespoke receivers	136 to 174 MHz with many intermediaries Actual frequencies encountered in the range of 137.765 to 170.300 MHz.	FM	5W	km	Double superhet rX product DTMF decoder

Table 2. Threat frequency table (as of JUN 2010) – cont. 1.

Serial	Threat configuration		Operating freq. (TX)	Modulation coding/schemes	Typical transmit	Typical link range	Comments
	receiver	transmitter					
Remote Switch – Purpose built devices							

4	PC game controller (SEGA)	ICOM IC-V68 KENWOOD or similar transceiver Bespoke receivers	Special frequencies as follows: 137.765 MHz 138.880 MHz 139.055 – 139.705 MHz 141.275 – 145.750 MHz 145.865 MHz 146.000 MHz 146.525 MHz 147.050 – 147.055 MHz 148.100 – 148.630 MHz 149.150 – 150.305 MHz 150.905 – 154.470 MHz 154.700 – 158.185 MHz 158.295 – 170.300 MHz	FM	5W	km	Double superhet rX product DTMF decoder
---	---------------------------	--	--	----	----	----	--

Table 3. Threat frequency table (as of JUN 2010) – cont. 2.

Serial	Threat configuration		Operating freq. (TX)	Modulation coding/ schemes	Typical transmit	Typical link range	Comments
	receiver	transmitter					
Remote Switch – Switcher unit							
5	Key-fob switcher unit	Bespoke purpose built	313.7 to 315.036 MHz	-	12 mW into 50	≤ 500m	Super regenerative rX as Sony car door lock
Remote Switch – Telemetry Module							
6	Linx rXM-418 Lr-S	Bespoke purpose built	418 MHz	AM	-	-	Single Superhetrodyne rX
COTS transceiver – professional							
7	ICOM IC-V68	ICOM IC-V68 or similar	136 to 174 MHz	NBFM ±5kHz DTMF	3-5W	km	Double superhet rX
8	ICOM IC-H16	ICOM IC-H16 or similar	136 to 174 MHz 151 to 172 MHz	FM with CTCSS+DTMS	3-5W	km	Double superhet rX
Hobby Radio Control – short range radio control							
9	-	-	27 to 35 MHz 49/50 MHz	-	-	≤ 100m	Feugyuan Toys product

Table 4. Threat frequency table (as of JUN 2010) – cont. 3.

Serial	Threat configuration		Operating freq. (TX)	Modulation coding/ schemes	Typical transmit	Typical link range	Comments
	receiver	transmitter					
Cordless telephones – High Power							
AARMS 10	Mostly Senao SN-258 Nokia Nokia Alhasha Brother Electron Samsung Chord music Famous Brand Product unbranded		115 to 227 MHz	NBFM	≤ 5W	≥ 10km LOS	Double superhet rX
			115 to 268 MHz majority in the frequency range of 225 to 236 MHz	NBFM	≤ 3W		
Wireless Network Phone							

11	Nokia 1100 Nokia 1112 Nokia 2300 Nokia 3310 Nokia 6100 Samsung SGH N-620 unbranded	900 MHz 1800 MHz	-	-	-	-
----	--	---------------------	---	---	---	---

Table 5. Threat frequency table (as of JUN 2010) – cont. 4.

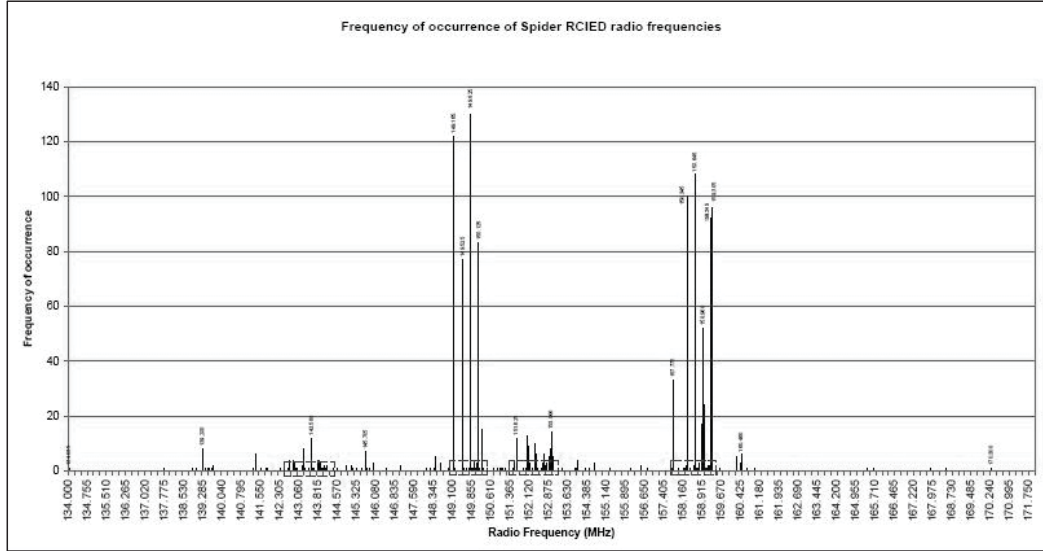

Figure 7. Threat frequency table (as of JUN 2010) – cont. 5.

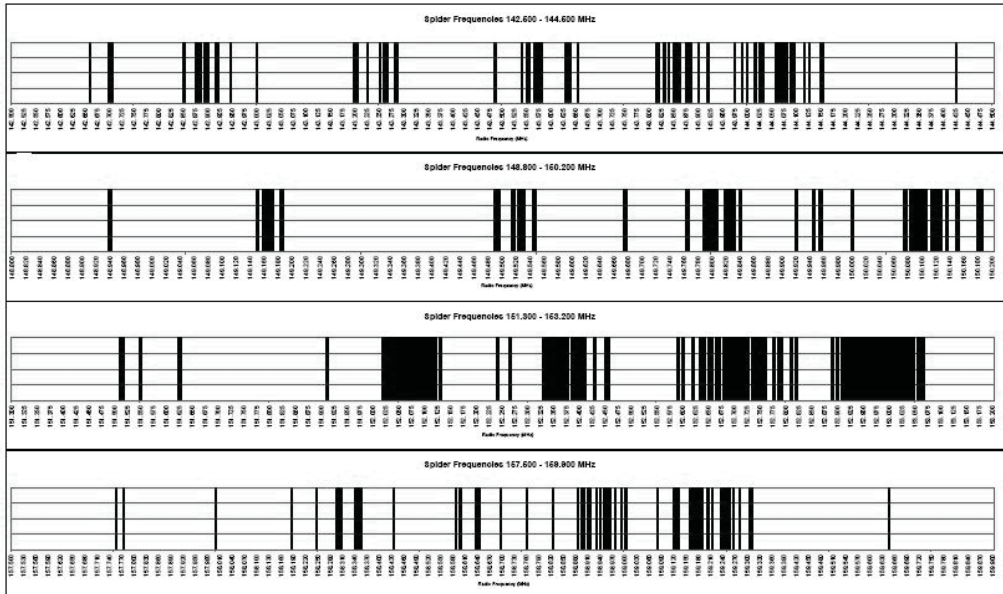

Figure 8. Threat frequency spectrum table (as of JUN 2010)

Abbreviations

- ACTD Advanced Concept Technology Demonstration
- AOI Area of Interest
- AO_r Area of responsibility
- BFT Blue Force tracker
- C2 Command and Control
- C2IS Command and Control information Service
- C4I Command, Control, Communications, Computers, and Intelligence
- CCID Coalition Combat Identification CDMA

Gulyás Attila: The Radio Controlled Improvised Explosive Device (RCIED) threat in Afghanistan

Code Division Multiple Access	CDS	Cross Domain Solution
CID	Combat Identification	CONEMP Concept of
Employment	DTMF	Dual Tone Multi Frequency
Controller	FAC	Forward Air
FBCB2	Force XXI Battle Command	Brigade and Below
FFT	Friendly Force Tracker	HPCP High Power Cordless
Phone	IFTS	ISAF Force Tracking System
ISAF	IP	Interoperability Profile
IT	International Security Assistance	Force
JTAC	Information Technology	Joint Terminal Attack Controller

NFFI	NATO Friendly Force Interface
PLI	Point of Interest
PIr	Passive Infrared
RBCI	Radio-Based Combat Identification
rOE	rules of Engagement
SA	Situational Awareness
SADL	Situational Awareness Data Link
SHAPE	Supreme Headquarters Allied Powers, Europe
SÍP	Service Interoperability Profile
TOC	Tactical Operations Center
TTP	Tactics, Techniques, and Procedures

References

- BARKEr, Alec (2010): *Improvised Explosive Devices In Southern Afghanistan and Western Pakistan*. In: *Counterterrorism Strategy Initiative Policy Paper*. April 2010, New America Foundation. COWArT, J. D. (2010): *Haditha Diary*. Xulon Press.
- DINGLEy, James (2009): *Combating terrorism in Northern Ireland*. routledge, London and New york.
- DOCTrINE General Military rreview, editions of 2009-2010
- GrAHAM, Adrian (2011): *Communications, Radar and Electronic warfare*. Wiley.
- GrOSS, David A. – SANGIN, Amir Zai (2008): *Afghanistan's Communications rrevolution; The Tele- coms rrevolution*. In: *The Washington Post*. Edition of 8 September 2008.
- Report on Progress Toward Security and Stability in Afghanistan (2010)*
- SCHENKEr, L. (1960): *Pushbutton Calling with a Two-Group Voice-Frequency Code*. In: *The Bell system technical journal*, 39 (1). <https://doi.org/10.1002/j.1538-7305.1960.tb03929.x>
- The commitment of French Land Forces in Afghanistan*. In: DOCTrINE General Military rreview 17/2009.
- US Congress House, Committee of appropriations, Department of Defence: Appropriations for 2006: Army recruiting and retention programs, US GPO 2006*.
- WUNDErLE, William D. (2010): *U.S. Army Weapons Systems 2010-2011*. Skyhorse, New york.
- http://books.google.hu/books?id=XztBogr9apcC&pg=PA227&dq=rcied+afghanistan&hl=hu&ei=t9LhTdWtL4n5sgaTq4DuBQ&sa=X&oi=book_result&ct=result&resnum=5&ved=0CEwQ6AEwBA#v=onepage&q=rcied%20afghanistan&f=false
- http://books.google.hu/books?id=tvaGMerkXLSc&pg=PA217&dq=rc+ied+afghanistan&hl=hu&ei=it-PhTde2D8TLswbWvpmLBg&sa=X&oi=book_result&ct=result&resnum=10&ved=0CFcQ6AEwC-Q#v=onepage&q&f=false
- http://books.google.hu/books?id=orgtAQAAIAAJ&q=rcied&dq=rcied&hl=hu&ei=2c_hTZvLMc7Fta-aHsZCEBg&sa=X&oi=book_result&ct=result&resnum=8&ved=0CEwQ6AEwBw
- <http://ew30.blogspot.com/2010/03/counter-remote-control-improvised.html>

Sub-Regional Cooperation in Central Europe – Past, Present and Future

GEBHARD, Carmen¹

There is a plethora of sub-regional arrangements that involve Central European countries. This article takes the Visegrád Group as an example of a minor range sub-regional grouping of states that can influence politics at a larger scale, and how this specific impact has changed in recent years following the transformation of the circumstances conditioning Central Europe's geostrategic position.

Introduction

Sub-regional cooperation in Central Europe has a long-standing tradition. There is a plethora of sub-regional arrangements that involve Central European countries, such as the Central European Free Trade Agreement (CEFTA), the Central European Initiative (CEI), the South East Europe Cooperation Initiative (SECI) as well as trilateral formations, e.g. between Romania, Hungary and Austria, or Romania, Poland and Ukraine. However, the most significant manifestation of Central European cooperation at the sub-regional level is the so-called Visegrád Group (VG), which came into being and is named after a summit held by four Central European countries in Visegrád/Hungary in February 1991. Preceding the creation of the VG, as consisting of the Czech Republic, Hungary, Poland, and Slovakia, there had been Austrian ambitions to form a Central European bloc of cooperation ("Projekt Mitteleuropa" – project Central Europe) based on the historical common ground of the Austro-Hungarian Empire.² It was only the formation of the VG, however, that had a more lasting and also political impact on the post-Soviet development of the Central European core region.³ This article therefore takes the VG as the most significant case of sub-regional cooperation to show how this sort of minor range sub-regional grouping of states can influence politics on a larger scale, and how this specific impact has changed in recent years following the transformation of the circumstances conditioning Central Europe's geostrategic position. This article places particular emphasis on the security-political relevance of the VG as such, and of the changes it has undergone since its inception.

1 Email: carmengebhard@hotmail.com

2 This Austrian initiative towards the creation of a cooperative arrangement for "Mitteleuropa" led i.a. to the creation of the so-called "Pentagonale" in 1989 (including Austria, Italy, Hungary, Yugoslavia and Czechoslovakia, and after the inclusion of Poland in 1991, the "Hexagonale"). These formations had a strong focus on science, culture and education, and largely refrained from taking on more sensitive political agendas. It was first divided about budgetary issues, and that kept them from any greater impact, and ultimately, the collapse of Yugoslavia and the escalation of tension between Serbia and Croatia constituted a major drawback for the cooperative framework. In 1992/93, the Hexagonale was turned into the Central European Initiative (CEI) to include Bosnia, Croatia and Slovenia. Today, the importance of CEI lies mainly in the area of scientific and cultural exchanges.

3 One of the main reasons why neither the Pentagonale nor the Hexagonale held potential for a long-lasting and distinct impact on the development of the Central European core region is that the constellation of countries involved was too heterogenic in terms of historical legacy, future strategic objectives, and regional interests. The inclusion of Yugoslavia and its subsequent breakdown in the course of the Balkan wars certainly played a decisive role. In any case, the inclusion of both Italy and Austria also produced some internal competition for moral and political leadership within the formation. See MAIER (1993) p. 8.

The accession of the four VG states to the European Union (EU), and their joining of NATO respectively are regarded as crucial turning points in this overall development.⁴

Rationale, Analytical Framework and Methodology

This article adopts a qualitative view on the development of sub-regional formations in Central Europe while the central focus lies on the transformation of objectives of the VG as one of the most significant cooperative arrangements in this region. The article sets out an analytical framework based on international scholarship on regional and sub-regional coordination.

The methods employed include process-tracing, qualitative literature review and content analysis. The material used mainly consists of secondary literature and key policy documents. Other primary sources such as treaties and conventions have been consulted in terms of indirect information gathering and as such they are not cited explicitly in the text.

Conceptualizing Sub-Regional Cooperation in the Context of Security

Sub-regional cooperation and sub-regionalism respectively can be defined as being constituted by an intensified or structured relationship between geographically adjacent entities to facilitate both inter-state and sub-state level cooperation in certain selected issue areas. As for the area of security and defence, sub-regional cooperative formations are often perceived marginal, as in most cases they mainly address “soft” security issues, and as such hardly ever gain centre stage in high politics. However, these sub-regional arrangements, which were in the past often discarded as secondary or tertiary players – or as Bailes⁵ put it, as the “cinderellas of European security” – in recent years, have been more and more acknowledged as highly influential elements in the multi-level setting of European security actors. With the transformation of security conceptions towards a broader comprehensive and inclusive understanding of the notion, the value of these groupings has started to get more attention and rightful recognisance.

The pragmatic issues that these groupings are usually focussed on, such as investment promotion, trade liberalization, private sector support, transportation, telecommunications, environmental protection, natural resources management, cultural and educational exchanges, tourism, border crossing facilitation, and energy management are increasingly seen from the point of view of confidence-building and are thus more acknowledged to have security enhancing effects.⁶ According to a comprehensive security approach as it has recently been adopted by all major security organizations including NATO, the UN, the EU, and the OSCE, these sub-regional frameworks are indeed well-suited to encounter new types of threats and security challenges like terrorism, organised crime, drugs and arms proliferation, human trafficking, natural and man made accidents, illegal migration or minority issues. The principle this effect is based upon is conflict avoidance through enhancing integration in multiple issue areas, which as such reflects much of the classical integration theory of neo-functionalism that suggests “spill-over” as the basic effect driving integration. As the following section will argue, however, more generally, classic integration theories offer fairly little analytical substance for the analysis and explanation of sub-regionalism as a manifestation of inter-state and sub-state cooperation.

4 The Czech Republic, Hungary and Poland joined NATO in 1999, Slovakia followed in 2004, and they all together joined the EU on 1 May 2004.

5 BAILES (1997) p. 28.

6 POP (2001) p. 133.

Theorizing Sub-Regional Cooperation

As pointed out above, the classic theory of integration through cooperation as suggested by neo-functionalism offers limited explanatory value for the analysis of sub-regional cooperation. The same could be said about intergovernmentalist accounts of integration or European integration more specifically. The specific line of argumentation based on an explicit focus on states as primary actors reduces the applicability of different variants of Intergovernmentalism to cases below the meta-level of European integration.

In the case of European integration theory, generally, two different patterns of theory application can be distinguished:⁷

- firstly, sub-regional cooperation can be treated as a micro-cosmic version of European integration, putting sub-regional and regional (i.e. European) integration at the same level of analysis, and thus suggesting a direct application of the respective bulk of theory to a specific minor-range case such as the VG.
- secondly, European integration theory could be employed as a framework, i.e. for the analysis of the inter-level relationship and ratio between the regional (i.e. European) and the sub-regional integration process in a specific region, e.g. Central Europe.

As the explanatory value of European integration theories has been considered as fairly limited in this second regard,⁸ specialist literature on this issue has rather adopted a systemic and more clinical view on sub-regionalism, trying to grasp in the first place, how sub-regional arrangements relate functionally to forms of cooperation or integration at larger scales, such as the so-called “regional” scale in the case of the EU. Such an analytical perspective is closer to the realm of International Relations theory than integration theory proper. What it borrows from the integration theoretical perspective, however, is the basic idea that regional and sub-regional formations could not only constitute subordinate and as such complementary levels of cooperation following similar logics of interaction but that they could also be seen as two substantially different things. Integration on the regional meta-level and the sub-regional meso-level could even be seen as two diametrically opposed processes which each in their own way take nation states beyond the state level of interaction. This is to say that in the course of integration at the European level power and governance is dislocated “upwards” to the supranational level while in the case of sub-regional forms of integration this movement goes “downwards” to regional (and local) entities.⁹ This aspect is also reflected by Downs:¹⁰

“At the dawn of the twenty-first century, twin forces continue to stretch the nation-state in opposite directions. States as they enter the new millennium are transformed not only by the centripetal pull of supranational integration, but also by the centrifugal forces of resurgent Regionalism. [...] Uncertainty generated by these countervailing forces prompts powerful and contentious arguments about the normative and empirical roles of subnational actors in increasingly complex webs of multi-level governance.”

Even though, depending on the perspective, these two dynamics do not always occur in terms of “countervailing forces” it should be taken into account that the alleged permanent cleavage between supranational “integratedness” and regionalist affixedness is likely to affect a nation state’s foreign policy orientation. (Sub-) Regionalism may also influence a state’s membership conduct

7 GEBHARD (2008) p. 74.

8 See e.g. PARKER (2000)

9 AMIN (2002) p. 387.

10 DOWNS (2002) p. 174.

and thereby have a positive or negative effect on the process of macro-level integration. These potentially conflicting dynamics between a macro-level entity and meso-level formations that intersect with the catchment area of the former are widely neglected in most theoretical models on regional (and European) integration.

Research on the phenomenon of sub-regionalism, which has also been studied under the label of “New regionalism”,¹¹ has also dealt with the relationship between two other apparently diverging dynamics that emerged in the Post Cold War World: (Sub) regionalism and Globalization. Movements and tendencies towards (sub)regionalization and globalization have been observed concurrently. Some experts have explained the increase of sub-regional activities as a direct effect or reaction of states to globalization.¹² Scholars have stated that many of these sub-regional formations have taken on important balancing and stabilizing functions to counter the multiple effects globalization can have, most particularly for small states.¹³ The particular asset of sub-regional forms of cooperation indeed lies in their potential to reflect specific concerns that are shared between a group of geographically adjacent states – concerns, which in broader contexts of integration such as the European or the transatlantic could be neglected in the long run.¹⁴ This implies that the long term success of sub-regional forms of cooperation and integration highly depends on the constellation of states working together and the internal balance among them. Drulák¹⁵ underlines in his assessments about the Benelux that internal structural homogeneity, common history as well as shared political objectives and long-term aims build essential criteria for sustainable success in sub-regional contexts. Besides their similarity, states cooperating in a sub-regional framework also profit from instances of economic or cultural interdependence.

Towards a Typology of Sub-Regionalism

It is generally one of the main conceptual questions that arises from the notion of *sub*-regionalism: how does the minor scale or sub-regional formation relate to the bigger whole, e.g. for the case of Central Europe, to the wider framework of European integration, which is regional in reach and comprises many issues that might also be dealt with at the sub-regional level by either state or sub state actors through varying intensities of cooperation. Dangerfield¹⁶ distinguishes between four alternative types or modes of subregional cooperation. According to his assessment, sub-regional formations can be classified as

- *pioneering*,
- *substituting* cooperation or integration at higher levels,
- *complementary* in this respect.

Pioneering cooperation at the sub-regional level involves higher degrees of integratedness on a certain issue area, which in a second instance exerts influence on meta-level integration. One of the most typical examples in this regard is the Benelux Group which essentially pioneered in different economic areas and most particularly in customs and border management matters. There are good reasons to see the Benelux Group as an influential and inspiring precursor of the European Communities.

11 TELÒ (2001)

12 E.g. SCHIRM (2002)

13 RÜLAND (2002) p. 201.

14 KISS-KÖNIGOVA-LUIF (2003)

15 DRULÁK (2000)

16 DANGERFIELD (2004) p. 246.

Substituting formations occur when states form cooperation on the sub-regional level as an alternative to a larger scale integration project, which could either be more or less committal than the minor scale formation in the making. Such an alternative constellation has certainly been built by the European Free Trade Association (EFTA), which was even explicitly intended to build a less far-reaching alternative to membership in the European Communities. In the case of EFTA, substitution did not take place in terms of conflictive sidelining of the main “European project”. It is important to point out, however, that this sort of substituting formation could also be employed in order to counter another formation. In this case, however, the relationship is rather that of two conflicting regional cooperation projects than of a sub-regional formation seeking to replace a respective meta option. Dangerfield¹⁷ also mentions the subtype of formations that are “*substituting involuntarily*”, pointing out that in some instances states might be forced to build up alternative formations because accession to a dominant formation is out of reach. This could be seen as being the case with the so-called “European Neighbourhood” which has been defined by the EU as comprising all states bordering the union without a mid or long term perspective of membership. What Dangerfield¹⁸ defines as *complementary* sub-regional cooperation in practice mainly appears in the context of pre-accession scenarios, meaning that sub-regional formation follows the aim of proactively preparing a group of states for the accession to a meta scale formation, e.g. the European Union for the Central European candidates before accession in 2004. One of the typical examples here for the economic field is the creation of CeFTA.

As will be argued further below, the VG has fitted neatly into the type of complementary sub-regional formation, promoting approximation and accession to the EU as a major political aim from its very outset. Elements of cooperation aiming at substituting the broader framework of European (and Transatlantic) integration are not existent in the VG context. The VG as such could even be said to have fulfilled the function of a pre-accession instrument, preparing the four countries for full membership in both NATO and the EU, based on a joint effort and conviction.

In contrast to movements of sub-regional integration in other parts of Europe,¹⁹ the Central European aspirations in the context of the VG have never assumed the character of a sidelining minor range alternative to the overall regional integration processes. In the course of the pre-accession processes with Central and Eastern Europe, both the EU and NATO directly related the candidate countries’ ability and ambition to resolve conflicts with neighbouring states conditionally with their prospects for membership.²⁰ Initiatives for sub-regional cooperation were thus welcomed as complementary to the overall aim of broader regional integration. Central and East Europeans were encouraged to conclude treaties affirming existing borders and guaranteeing ethnic minority rights and to establish new forms of cooperation, i.a. cross-border economic zones and joint peacekeeping forces.²¹

Given this close link of the VG with the joining of the meta level process of European and transatlantic integration turns the question of its post-accession role into an important one. What

17 DANGERFIELD (2004) p. 247.

18 DANGERFIELD (2004) p. 247.

19 Previous research that I (see Gebhard 2008) have conducted in the area of sub-regional cooperation in the Baltic Sea region has shown that some cooperative arrangements put in place by either sub-regional actors or states in the region were aimed at sidelining the wider European integration process, and any regional policies that might have been launched and driven by the European core in Brussels. This has been the case with the so-called Northern Dimension (ND) of the European Union and the Swedish attitude in the context of the creation of the Council of the Baltic Sea States (CBSS). Instead of sticking with the broader objective of performing like a fully fledged EU member state – like Finland did in the context of the ND – Sweden, on many different occasions, clearly favoured the sub-regional forum offered by the CBSS, and placed it as a priority above the objective of European integration.

20 BAILES-COTTEY (2006) p. 199.

21 KAVALIUSKAS (2003)

in fact is cooperation in the context of the VG, after the four countries have reached their common goal of firstly joining NATO and secondly EU accession? What political aims now build the framework for the cooperation between these states? And what in particular has changed in respect to the security political relevance of the VG? In search of viable answers to these questions, this article will first turn to a historical overview of sub-regional cooperation in Central Europe up to the year of 2004, i.e. the political turning point, when the V4 finally joined the EU, and were therefore not only part of the transatlantic community but also of the more narrow circle of EU member states.

Sub-Regional Cooperation in Central Europe in the post Cold War Era

After the breakdown of the bipolar world order and the end of the Cold War, a number of sub-regional formations emerged in Central Europe. Despite their functional and political differences, most of these formations were created in the framework of the broader aim of “returning to Europe” or “reintegrating to the West”. These sub-regional arrangements took on various different functional frameworks, ranging from mutual trade liberalisation to more generic cooperation e.g. in order to enhance leverage vis-à-vis the EU,²² and coordination around pre-accession issues. It can be said that generally, these various sub-regional groupings which emerged in Central Europe after the seminal year of 1989 have played important roles in respect to the reconstructing of the international security order, albeit on a very low profile. In a way they helped to fill the political vacuum²³ that resulted from the breakdown of the Warsaw Pact and the dissolution of the CMEA (Council for Mutual Economic Assistance), and reconnected states that were just about to explore the opportunities and responsibilities emerging from the new geostrategic setting.²⁴ Much of this wave of sub-regional formation that caught many parts of Europe after the end of the Cold War was constituted by the re-emergence of long-dormant regional patterns of cooperation that had until then been dominated by the superpower overlay.²⁵

The *Central European Initiative* (CEI) was the first sub-regional formation created after the end of the Cold War. It was founded in 1989 under label of “Pentagonale” as a political, economical, cultural and scientific organisation which aimed at supporting its members in approaching the goal of Western integration. Austria, Italy, (then) Czechoslovakia, Hungary, Poland, and (then) Yugoslavia were among the founding members although Poland joined only one year later to form the “Hexagonale”; in 1992 CEI was joined by Slovenia, Bosnia and Herzegovina, Croatia, and the FY republic of Macedonia, in 1995, Albania, Belarus, Bulgaria, Moldova, and Romania, in 2000, Serbia, in 2006, Montenegro. Taking in the Yugoslavian states eventually turned out to weaken the initiative as such. The more states joined the CEI, the more heterogeneous it became, and the less leverage it generally had in respect to meso and meta range levels. The CEI generally kept a rather low profile, connecting its member states in uncontroversial matters such as culture and education in the first place.²⁶

Economic cooperation and integration in Central Europe took place in the framework of the *Central European Free Trade Agreement* (CEFTA), which was concluded in 1992. In a way, CEFTA could be regarded as a close relative of the VG. However, from its very outset, CEFTA had exclusively limited its activities to the realm of economic cooperation and trade liberalisation respectively.

22 DANGEFIELD (2008a) p. 137.

23 DWAN (2000) p. 89.

24 BAILES (1997) p. 28.

25 HYDE-PRICE (1997) p. 14.

26 DANGEFIELD (2008) p. 644.

CEFTA has thus always had a more clear-cut functional agenda than the VG. All participating countries signed association agreements with the EU, and more generally, the CEFTA was a forum for accession preparation. In contrast to the VG, CEFTA therefore also changes its membership constellation depending on whether a state has already joined the EU or not. After joining the EU in 2004, the V4 left CEFTA as a direct result of the full membership. In terms of its functional constitution, VG has therefore always been more closely related to the CEI than to the CEFTA. What connects the latter two though is the shifting geographical scope of their activities: with the Central European states approaching EU accession both CEFTA and CEI were reoriented towards taking in the South-eastern countries on the Balkans, and added considerable heterogeneity to their internal constellation.

As pointed out in the introduction, by contrast, the VG fulfilled a special role in various respects: Its membership structure remained stable throughout the years, its constellation therefore ultimately homogenous, and its political agenda fairly consistent. The following abstract seeks to outline the constituting years of the VG, and thereby, to assess on which political aims the cooperative formation was built upon. This should help to allow further analysis about how its agenda has changed throughout the years, and most particularly after the V4 have joined the European Union.

The Visegrád Group – its inception and early years

The VG was formally inaugurated at a meeting of Czechoslovakia, Hungary, and Poland, the so-called V4 (with today the Czech Republic and Slovakia), which was held in Bratislava in April 1990 following an initiative by Václav Havel on mutual policy coordination and the synchronization of future steps towards regional integration. Due to the fact that at this point particularly the Hungarian and the Polish delegations were still dominated by communists of the Soviet era, progress in the multilateral talks were fairly modest. Only by the end of 1990 and in early 1991 did the process of sub-regional formation gain new momentum. At a meeting of the then three founding members in February 1991 in Budapest, the so-called Visegrád Declaration was signed. The dominating argument in the declaration built on the common past and shared historical experiences that would compel the states to cooperate at a larger scale. The presidents, foreign ministers and selected parliamentarians of the three states recognized the potential this sort of sub-regional cooperation could bear for their long term stance in European matters of integration.²⁷

The specific setting in the years 1990 and 1991 truly gave the three post communist states “no alternative to cooperation”.²⁸ On the one hand, they sought to disentangle from the CMEA, Warsaw Pact and Soviet legacy, on the other hand, there had been broad awareness that joining the West was a yet far away option, and that in this particular setting, even the most reformist post communist regimes could be expected to be openly welcomed by the West.²⁹ In its first years of existence, the VG did not show persistent levels of activity and proactivity respectively. Accordingly, throughout the years, there have been phases where the VG as a sub-regional formation was less visible and thus less influential than in other times. Analysts have detected one such low profile phase in the years between 1993 and 1998, when compared to the very first years of 1990-1992, the VG seemed to lose most of its momentum. It appears important to point out that shortly after its inception, the VG adopted a fairly ambitious political agenda explicitly including so-called hard power issues such as the dismantling of old Soviet structures and overcoming the totalitarian

27 COTTEy (1999) p. 74.

28 VACHuDOVA (1993) p. 39.

29 DANGE+FIELD (2008) p. 645.

past by way of security and defence cooperation and common concerted transformation. There is empirical evidence that in August 1991, during the coup in Moscow, there were political and military consultations among the V4.³⁰ This sort of sensitive involvement has not been repeated at any other point of the VG's existence; however, the VG states established a system of coordination in security and defence issues, agreed on measures for closer cooperation in military technology development, production and procurements, and they concluded each a bilateral military cooperation agreement with the others.³¹

From the very beginning, the V4 also sought to get closer to the political project of European integration, which at this point did not yet have any explicit security or defence related element. When in December 1991 the EU decided to sign Europe Agreements with the V4, their proactive stance shown in the form of sub-regional jointness had been one of the major criteria for the EU to grant them this sort of privileged status. There is evidence that the Krakow Treaty, that was signed in December 1992 to create CEFTA, would not have come into being if the Central European states had not yet shown their ambition towards regional integration in the form of the VG.

The way VG cooperation touched upon issues of security after 1992 was rather through indirect stabilizing effects than through explicit security or even defence related integration. An important aspect in this regard was that the VG states managed to sort out ideological divergences among themselves, which also had an impact on their shared conviction about which framework would best suit each their strategic necessities. In the early years of the VG, there had been internal divisions about whether the Central European states should be geared to a pan-European security framework as then constituted by the Organization for Security and Cooperation in Europe (OSCE) or rather a more comprehensive transatlantic framework as offered by NATO. The V4 used the group as a forum to discuss the advantages of each setting, and to negotiate about whether association or membership in NATO was at all desirable and feasible. These instances of convergence were highly conducive to the fact that the then three states increasingly had to be dealt with by third partners as a single entity. Being addressed as a group of integrated states by the EU constituted a major advantage for the post communist states as unavoidably, it helped them to pool their qualities and balance each others political and economic shortfalls to enhance their leverage as a group. "Visegrád" as a label became highly visible in the early years of the group's existence, and it was increasingly seen as Central Europe's defining entity, that external actors had to address if they wanted to interact with any one of the participating states.³² One of the decisive factors supporting this effect was surely the group's comprehensive functional agenda, which covered political issues as much as matters of research, culture and education. This also helped the V3 to be addressed more directly from outside.³³

It appears important to point out that at this early stage of the VG, cooperation was mostly a high level elite issue with fairly little involvement of subregional actors and actors of the civil societies. According to some analysts³⁴ this was mainly due to the lingering influence of the Soviet and communist legacy, which prevented the political leaders from moving their interactions with lower levels beyond the sphere of discussion and planning. The very strong focus on the overarching aim of "returning to the West" also put the emphasis of acting power with the governing level of the three states.

30 RUSNAK (2001) p. 249.

31 COTTEY (1999) p. 75.

32 FAWN (2001) p. 54.

33 COTTEY (1999) p. 76.

The intermediate phase 1993-1998

Scholars who have sought to trace the development of VG internal dynamics identified the period of 1993 to 1998 as a period of passivity and decline.³⁵ One of the conditioning factors was that after the division of Czechoslovakia, both the Slovakian and the Czech leadership turned against the VG as a framework for subregional cooperation. The years of 1992 and 1993 also saw the emergence of tensions between Hungary and Slovakia, which for themselves hampered cooperation in the VG framework. To many observers of the time it looked like the VG was going to decline before at all reaching its most fundamental aims. To some extent, even the establishment of CEFTA held the potential to undermine the leverage and purpose of the VG, as it took away much of the attention and appeared to offer a reliable framework for itself. This period also saw the rapid deterioration of Slovakia in its process of approaching the transatlantic security system and European integration process. Instead of adopting and cultivating a cooperative air, the V4 immersed in divergences and fell back into isolationist and individualist thinking.³⁶

In 1994, at the NATO summit in Prague where the V4 were to meet US president Bill Clinton to discuss their future relationship with NATO, the Czech defence minister declined to join his fellows from the other VG states stating that he was not convinced of any lobbying strategies to precede these sorts of negotiations.³⁷ The subsequent exclusion of Slovakia from NATO and EU membership negotiations constituted another drawback in the very short history of the VG and fuelled the general criticism both regional and international analysts had raised beforehand. Some critics declared the VG as “clinically dead”, others instead ascertained that the group was going through a “dormant phase of transformation”, which however, would be succeeded by more active times.³⁸ During this period, CEFTA in turn experienced a phase of high visibility and activity, which exacerbated external impression about the alleged crisis of the VG. CEFTA also took on much of the EU pre-accession agenda, which had lost momentum in the VG framework. It is important to point out, however, that until CEFTA expanded in 1996, the CEFTA summits provided important opportunities for keeping up the dialogue among the V4. Cooperating within the framework of CEFTA helped to rebuild confidence in sub-regional formations, and as such, it certainly helped to pave the way towards a reactivation of the VG in the form of “Visegrád 2”.³⁹ Another decisive factor that brought the V4 leaders to cooperate more closely was the progress in approaching NATO, which became most evident in 1997 when the formal membership invitation was issued to Poland, Hungary and the Czech Republic. The deteriorating position of Slovakia in this regard did not impede further efforts in reviving the VG as a forum for sub-regional cooperation.⁴⁰

Reactivation and Visegrád 2 until the 2004 EU Enlargements

The reactivation of the VG in 1998 was to a very large extent only possible after both in the Czech Republic and in Slovakia the political leadership had changed towards a more pro-VG team. These high level changes also marked the end of the strong superiority complex, which had previously kept the Czech Republic from fully investing in a cooperative framework. Individualistic and

35 DANGEFIELD (2008) p. 652.

36 VACHUDOVA (1993) p. 40.

37 COTTEY (1999) p. 77.

38 DANGEFIELD (2008) p. 657.

39 DANGEFIELD (2002) p. 98.

40 RHODES (1999) p. 54.

competitive tendencies abated to leave room for a more cooperative air. This phase also saw the first steps towards the rehabilitation of Slovakia in respect to the EU and – to some extent – also to NATO, although clearly it was still lagging behind its V4 partners. Although the progress of Poland, Hungary, and the Czech Republic towards NATO accession made the inequalities and Slovakian shortfalls more obvious, the general movement had a positive impact on the dynamics inside the VG. The motive of “assisting Slovakia” in catching up gained momentum and fuelled cooperation in the framework of the VG. Most of all the Czech Republic had a clear interest in keeping Slovakia up to the pace of integration as a disjunction of the accession processes to the EU would have caused a series of practical problems, e.g. in respect to their bilateral customs agreement that had been concluded upon the division of Czechoslovakia.⁴¹

The CEFTA summit held in Prague in September 1998 served as a forum for the V4 to prepare the reactivation of the VG. The reconvened VG then met in October 1998 in Budapest to define a new agenda for “Visegrád 2”. This new agenda was characterized on the one hand by a stronger recourse to the original aims of integration to the West, i.e. the accession to both NATO and the EU, and on the other hand by a clear focus on intra-VG cooperation activities i.a. in the areas of foreign affairs, internal affairs, education, culture, society, science, technology, environment, infrastructure, and cross-border cooperation. Cooperation in foreign affairs was meant to include mutual consultation and information transfer as well as strategic concentration of actions in the context of NATO and EU pre-accession processes. Internal affairs cooperation was to include issues such as border and immigration affairs, fight against organised crime as well as fight against human and drug trafficking.⁴² What was also new to the VG framework was the establishment of early forms of institutionalization of the intergovernmental cooperation. The constitutive leaders felt a need to formalize their relationships within the group in order to on the one hand secure stability and continuity, and on the other hand to support the growing functional agenda and its implementation. From then on, the V4 met at least twice a year (a) in president formation, (b) foreign minister formation, and – as needed (c) the formation of other ministers. Regular meetings were also foreseen for the ambassadors of the V4 and the parliamentary representatives. As another structural innovation, the V4 established the institution of a rotating presidency, which as an instrument had already been employed successfully by other sub-regional formations in other parts of Europe.⁴³

Another decisive novelty has been the establishment of the so-called International Visegrád Fund (IVF), which essentially marked the transition of the VG’s activities towards a more formalized type of sub-regional organization. The main idea behind the creation of the fund was to enable the formation to adopt a more hands-on approach in the region and to allow the V4 to complement their external activities with measures and initiatives concerning its internal sphere. The plan was to provide funding in the realm of education, arts, culture, science and technology in the first place – which in fact were all low profile issues. However, given this new asset of having its own financial instrument, the sense of activity also changed towards a more proactive and dynamic attitude, which undoubtedly added new momentum to the VG as a whole. It appears important to point out that the IVF was established as a truly permanent institution with its own staff and dedicated premises. The IVF also established a system of obligatory financial commitment among the V4, and as such, considerably strengthened the internal morale and level of allegiance and loyalty.⁴⁴ The

41 DANGEFIELD (2008) p. 644.

42 For more detailed information on the “Visegrád 2” agenda, consult the 1998 annual report available online at www.visegradgroup.org.

43 GEBHARD (2008) p. 85.

44 DANGEFIELD (2008) p. 645.

existence of such a binding and formalizing framework also enhanced the visibility of the VG in the region as such and fostered working relations with various civil society actors. Some observers also pointed at the normative effect such a formal institution could have by giving “meaning to the rather abstract idea of a regional identity”⁴⁵

This formative phase in the development of the VG also saw the introduction and establishment of the “V4 plus” in the overall internal and – even more importantly – external rhetorics with cooperation partners at various levels. Coining the four states as belonging to one distinct group and formation already had considerable impact on the visibility and the way they were seen and addressed from outside – be it by other states or the EU or NATO. Adding the “plus” now was to communicate the openness of the formation to cooperation with third parties at all levels, which again enhanced the overall leverage and visibility of the VG beyond its own regional sphere. Some critics⁴⁶ also pointed out that the “V4 plus” formula had to be seen as the result of a weak compromise between the four about whether the formation should be opened to enlargement. Until today, the V4 have not been able to agree on any such extension of their regional reach, which may either be a reason why the group managed to persist, or a reason why it has reached and passed its functional zenith already.

The Post-Accession Role of the VG

From late 2002 onwards, when one of the major goals of the VG appeared within secure reach – EU accession of the V4 including rehabilitated Slovakia – discussions started about the potential post-accession role the formation could take in pursuing the interests common to the Central European region. This was indeed a crucial moment in time that – according to some observers – decided about the dissolution or continuation of the group. What was particularly decisive is the fact that much of the purpose of the VG to exist at all was bound to its activities in pre-accession matters. It was therefore legitimate to raise the question whether the VG was actually still needed once the EU accession had been performed. The end of 2002 marked the beginning of – as it first looked like – a fairly low profile phase of reflection, during which each of the V4, for themselves and in mutual exchange, would seek to figure out a future political agenda that would keep the group alive. What then happened among the V4, and most particularly between Hungary and the Czech Republic, in the years preceding their accession to the EU, however, fuelled speculations about the “clinical death of Visegrád”, about 11 years after its inception, and even the “end of Central Europe”.⁴⁷ The most sensational instance where the two alleged regional partners clashed was after the Hungarian Prime Minister, then Viktor Orbán, declared the so-called Beneš decrees as incompatible with the Czech membership in the EU. Orbán’s affront against the Czech Republic in this sensitive moment of pre-accession severely troubled the internal relations within the VG and led to repeated situations where both the leaders of the Czech Republic and of Slovakia refrained from taking part in VG meetings, leaving the game of four to the two remaining, Hungary and Poland.

In face of these troublesome events, critics exceeded each others imagination in drawing dark pictures of the VG’s post accession role. One of the strongest arguments at the time was that there would be little left for a common agenda, once the integration to the West in the form of both NATO and EU membership had been achieved. Critics pointed at the internal differences and the inherent heterogeneity of the group with Poland rather moving into the direction of taking on a proactive

45 VAUGHAN (2000) p. 1.

46 E.g. DANFIELD (2008) p. 646.

47 DANFIELD (2008) p. 647.

role within the EU and the Czech Republic, Hungary and Slovakia rather assuming a defensive and inward-looking if not passive role and style. Also the difference in size and factual political power and leverage between Poland and its VG partners was discussed as a potential divisive factor in the post-accession phase. Pehe⁴⁸, political analyst with a special focus on the VG, suggested that the smaller states of the VG, the Czech Republic, Hungary, and Slovakia would soon reorient themselves and seek other frameworks for sub-regional cooperation. Poland in turn would – because of its size and respective political leverage – once a full member of the EU, turn away from its regional allies and seek closer cooperation with large member states such as Germany and France.

All controversies and criticism aside, at their meeting in May 2004, the V4 decided to continue their cooperation in the framework of the VG and reconfirmed their conviction towards sub-regional forms of cooperation in addition to integration into the EU. The resulting Visegrád Declaration of 2004 indicated the following four main areas for future activity⁴⁹ and cooperation:

- within the VG,
- within the EU, i.e. on EU matters where common regional interests are concerned,
- with other partners be it on state or lower levels,
- within NATO and other international organizations.

The declaration also confirmed the cooperation mechanisms already in place concerning the prime ministerial, ministerial, presidential and parliamentary levels as well as the level of cooperation with other actors from civil society.

Outlook and Conclusion

The Visegrád Declaration of 2004 has set the framework for the VG's activities after the seminal goal of full EU membership has been achieved. If one sought to draw conclusions from what has been put out as strategic goals in the early years of the VG and the sort and type of ambitions that can be found in today's version of this very same formation, it is impossible not to ascertain that the profile is considerably lower. From having an identity forming and regionally uniting effect on the states involved and their people, the VG has now turned into a somewhat fuzzy and questionably influential formation. There are reasons to doubt about whether the VG has succeeded in building up a Central European bloc within the EU, if ever that was the agreed aim of all the four. Looking at the developments since the 2004 accession of the V4 there is a clear orientation of e.g. Poland away from its regional allies towards the power game among the big 6 within the European Union. Overt security political discussions have become rare within the VG and as a result also the external effect and visibility of the group as a political formation has lost substance. The very low profile issues that VG cooperation has been about recently might arguably have importance in the perspective of a more comprehensive conception of security. It is nevertheless to be noted that each of the four individually no longer (if they have ever) feel bound to the VG legacy when pursuing their strategic goals within the EU or also within NATO. In a way, and put more diplomatically, the VG has become more open and informal, which in other words could also be called diluted and less substantial. Despite all these critical factors, however, it must not be denied that the regular meetings as established and institutionalized in the VG framework do keep up some sort of togetherness or "we-feeling", which in a second instance sharpens the V4 awareness about their common interests and potential pay-offs of cooperation, most importantly within the EU framework. How-

48 PEHE (2004)

49 For more detailed information on the 2004 Visegrád declaration, consult the full text available online at www.visegradgroup.org

ever, so far there is not very strong evidence that the VG leverage has reached as far as to really establish a Central European group within the EU. Internal political changes within the national leadership have proved to be powerful intervening factors that very often keep the V4 from really maximizing the cooperation payoffs within the group. More research will be necessary to pin down some of these preliminary conclusions and the VG as such will therefore keep its attractiveness as a meaningful case of complementary sub-regionalism.

Bibliography

- AMIN, Ash: [Spatialities of Globalisation](#). In: *Environment and Planning*, No. 34/2002, pp. 385-399.
- BAILES, Alyson J. K. (1997): *Sub-regional Organizations: The Cinderellas of European Security*. In: *NATO Review*, Vol. 45:2, March 1997, pp. 27-31.
- BAILES, Alyson J. K. – COTTEY, Andrew (2006): *Regional Security Cooperation in the Early 21st Century*. In: *SIPRI Yearbook 2006. Armaments, Disarmament and International Security*. SIPRI Stockholm 2006, pp. 195-223.
- COTTEY, Andrew (1999): *The Visegrád Group*. In: id. (ed.): *Subregional Cooperation in the New Europe*. Macmillan: Basingstoke 1999, pp. 69-89. <https://doi.org/10.1007/978-1-349-27194-8>
- DANGERFIELD, Martin (2002): *Sub-regional Cooperation in Central and Eastern Europe. Support or Substitute for the 'Return to Europe'?* In: *ROSS*, Cameron (ed.): *Perspectives on the Enlargement of the European Union*. Brill: Leiden, pp. 95-118.
- DANGERFIELD, Martin (2004): [Regional Cooperation in the Western Balkans. Stabilisation Device or Integration Policy](#). In: *Perspectives of European Politics and Society*. Vol. 5:2, pp. 243-272.
- DANGERFIELD, Martin (2008): [The Visegrád Group in the Expanded European Union: From Preaccession to Postaccession Cooperation](#). In: *East European Politics and Societies*, Vol. 22:3, pp. 630-667.
- DANGERFIELD, Martin (2008a): *The Impact of European Union Membership on Central European Subregional Cooperation*. In: *PETRITSCH, Wolfgang – SOLIOZ, Christophe (eds.): Regional Cooperation in South East Europe and Beyond. Challenges and Prospects*. Nomos: Baden-Baden, pp. 129-145. <https://doi.org/10.5771/9783845210292-127>
- DOWNS, William M.: [Regionalism in the European Union. Key Concepts and Project Overview](#). In: *Journal of European Integration*, No. 3/2002, pp. 171-177.
- DRLÁK, Petr (2000): *Zkušenost země Beneluxu*, cited in *KISS/KÖNIGOVA/LuIF 2003*.
- DWAN, Renata (2000): *Subregional, Regional and Global Levels. Making the Connections*. In: *HEROLF, Gunilla (ed.): Subregional Cooperation and Integration in Europe. Conference Papers 26/2000*. The Swedish Institute of International Affairs: Stockholm 2000, pp. 81-96.
- FAWN, Rick (2001): *The elusive Defined? Visegrád Cooperation as the Contemporary Contours of Central Europe*. In: *Geopolitics* 6:1, pp. 47-68. <https://doi.org/10.1080/14650040108407706>
- GEBHARD, Carmen (2008): *Unravelling the Baltic Sea Conundrum. Regionalism and European Integration Revisited*. Nomos: Baden-Baden 2008. <https://doi.org/10.5771/9783845212395>
- HYDE-PRICE, Adrian (1997): *Security and Integration in Mitteleuropa. Towards a New Research Agenda*. Paper presented at the European Communities Studies Association (ECSA), 5th Biennial Conference, Seattle USA, May/June 1997.
- KAVALIŪSKAS, Tomas (2003): *Visegrad, Nato and EU. The Difficult Balancing Acts of the New EU Member States*. In: *Eurozine* 1:2003. www.eurozine.com.
- KISS, László – KÖNIGOVA, Lucie – LuIF, Paul (2003): *Die "regionale Partnerschaft": Subregionale Zusammenarbeit in der Mitte Europas*. In: *österreichische Zeitschrift für Politikwissenschaft* 32:1, pp. 57-75.
- MAIER, Charles S. (1993): *Whose Mitteleuropa? Central Europe Between Memory and Obsolescence*. In: *BISCHOF, Günter – PELINKA, Anton (eds.): Austria in the New Europe*. Transaction Publishers: New Brunswick, pp. 8-18.

- PARKER, Noel (2000): Integrated Europe and its 'Margins'. Action and Reaction. In: Id./ARMSTRONG, Bill (eds.): *Margins in European Integration*. Houndmills 2000, pp. 3-27.
- PEHE, Jiří (2004): Is the end of Visegrád in the Offing? Available online at www.pehe.cz.
- POP, Adrian (2001): Sub-regional Groupings as Security Providers in Central and Southeastern Europe. In: *Medzinárodné Otázky/International Issues*, Vol. X:1, 2001, pp. 131-141.
- RHODES, Matthew (1999): Post Visegrád Cooperation in East-Central Europe. In: *East European Quarterly* 23:1, pp. 51-67.
- RÜLAND, Jürgen (2002): "Dichte" oder "schlanke" Institutionalisierung? Der Neue Regionalismus im Zeichen von Globalisierung und Asienkrise. In: *Zeitschrift für Internationale Beziehungen* 9:2, pp. 175-208.
- RUSNAK, urban (2001): One year Experience of the International Visegrád Fund Activities. In: *Central European Political Science Review* 5:2, pp. 244-251.
- SCHIRM, Stefan (2002): *Globalization and the New Regionalism. Global Markets, Domestic Politics and Regional Cooperation*. Oxford-Malden, MA 2002.
- TELÓ, Mario (2001) (ed.): *European Union and New Regionalism. Regional Actors and Global Governance in a Post-Hegemonic Era*. In: *The International Political Economy of New Regionalism Series*. Ashgate: Aldershot et al. 2001.
- VACHUDOVA, Milada Anna (1993): The Visegrád Four: No Alternative to Cooperation? In: *REF/RL Research Report* 34:2, August 1992, pp. 38-47.
- VAUGHAN, David (2000): Central European Cooperation Goes Into a New Gear. In: *radio Prague*, August 2000, available online at www.radio.cz.

Health screening examinations in cardiovascular risk estimation

KóróDI Gyula MD¹

The most important elements in prevention of cardiovascular (and cerebrovascular) diseases are screening and managing the risk factors, such as high blood pressure, high total cholesterol or high blood glucose etc.. The best way to find out the personal specific risk profile is through screening tests during annual doctor visits. Regular cardiovascular and cerebrovascular screenings are very important because they help detect the risk factors in their earliest and asymptomatic stages. This way, the patients can treat their risk factors with lifestyle changes and pharmacotherapies, if appropriate, before it ultimately leads to the development of cardiovascular disease. For many patients, screening results can serve as a wake-up call. When the regular test comes back and the patient sees and understands the abnormal parameters, it becomes extremely personal. The idea of making lifestyle changes is not just a recommendation in a pamphlet; it is something that can impact the patient's whole life, habits and health. The best way for optimal health benefits is through regular cardiovascular screening tests beginning at age 20. Because of very high cardiovascular morbidity and mortality, early and regular screenings could be a basic element of preventive health care.

Keywords: cardiovascular disorders, screening examination, preventive care, risk estimation

Screening examinations in general medicine

We can define health screening as the preclinical identification of disease by means of tests or examinations that can be applied rapidly. In practical medicine screening is a preventive strategy used in a population to detect a disease before the signs or symptoms of it. The intention of screening is to identify risk factors in a community, for earlier intervention and management in the hope to reducing morbidity and mortality. Screening refers to a test or exam done to find a pathological condition before symptoms begin, when they are much easier to treat. The screened condition itself must be important, recognisable and clearly understood. Screening is intended for all people, in an identified target population, who do not have symptoms of the disease or the condition being screened for. Not everyone will take part in a screening program, there are factors that differ between those willing to get tested and those who are not. One hopes people with a higher risk of a disease are more likely to get screened. Which tests you need depends on your age, your sex, your family medical history and whether you have risk factors for certain diseases. For example, being overweight may increase your risk of developing diabetes or hypertension and can increase the risk of cardiovascular disease or stroke. Nowadays in Hungary's financial and economic circumstances employees can be the main target population of screening programs, because they are the key elements in GDP production.

The screening test itself must be a good one. It must be sensitive, that is to say people with the

¹ Quatos Ltd. Email: korodigy@freemail.hu

disease will correctly test positive, and it must also be specific, so that those without the disease will correctly test negative. Ideally the test would pick out all diseased individuals and be positive for that disease only. They must be also be cheap, easy, reliable and as painless as possible. For these reasons a test used in a screening program, especially for a disease with low incidence, must be very specific in addition to acceptably sensitive.

Screening has advantages and disadvantages: the decision whether to screen must be decided by balancing all factors. Screening can detect medical conditions at an early stage before symptoms present themselves, while treatment is more effective for later detection. In the best of cases an early diagnosis can be life-saving because of the highly effective treatment modalities. Like any medical test, the tests used in screening are not perfect. The test result may incorrectly show a positive for those without the disease (false positive), or negative for people who have the condition (false negative). Screening involves cost and use of medical resources on a majority of people who do not need treatment. False positive results and unnecessary investigations can provoke adverse effects of screening procedure: stress, anxiety, discomfort, radiation or chemical exposure. Screening may identify abnormalities that would never cause a problem in a person's lifetime.

Several types of screening exist in medicine; the annual and general medical examination is a common form of preventive health care. universal check ups involve screening of all patients, and case finding involves screening a smaller group of people. Primary care is the term for the health care services that play a role in the local community. It refers to the work of general practitioners, pharmacists, and nurse practitioners. Continuity, preventive care and health education are the key characteristics of primary care, as patients usually prefer to consult the same practitioner for routine check-ups. Secondary care is the health service provided by medical specialists and other professionals who generally do not have first contact with patients. Allied health professionals, such as occupational therapists also generally work in secondary care. Tertiary care

(advanced medical investigation and treatment) is specialized consultative health care, usually for inpatients and on referral from a primary to secondary professionals.

Screening examinations in cardiovascular prevention

A family's medical history can reveal the health risk in the family and allow you to identify patterns that might be relevant to the patient's own health. We can use the medical history data to assess the risk of diseases, recommend changes in lifestyle habits to reduce the risk of disease and determine the frequency and type of screening exams. All the employee and the patient need to do is to answer the questionnaire about the family & personal medical history, about the risk factors at the workplace and about the patient's lifestyle. After this it is a medical task to plan and execute the personalised health check up. In the civilised world more than half the cases of illness and the leading cause of death are cardiovascular diseases. Because of this one of the most important parts of the medical screening system is cardiovascular risk profile estimation. Numerous risk factors of cardiovascular diseases have been known, most of them relate to life style (cigarette smoking, drug abuse, excessive alcohol consumption, bad eating habits, inadequate physical activity etc.) but other environmental risk factors, genetics or geographical differences in terms of access to a health care system, also could significantly influence mortality.

using the simple European SCORE help we can calculate the statistical risk for fatal heart attack for a period over 10 years. If we know the patient's age (aged 40 and over) sex, smoking status, blood pressure and serum cholesterol level we can estimate the 10-year risk of fatal cardio-vascular attack in percentage.

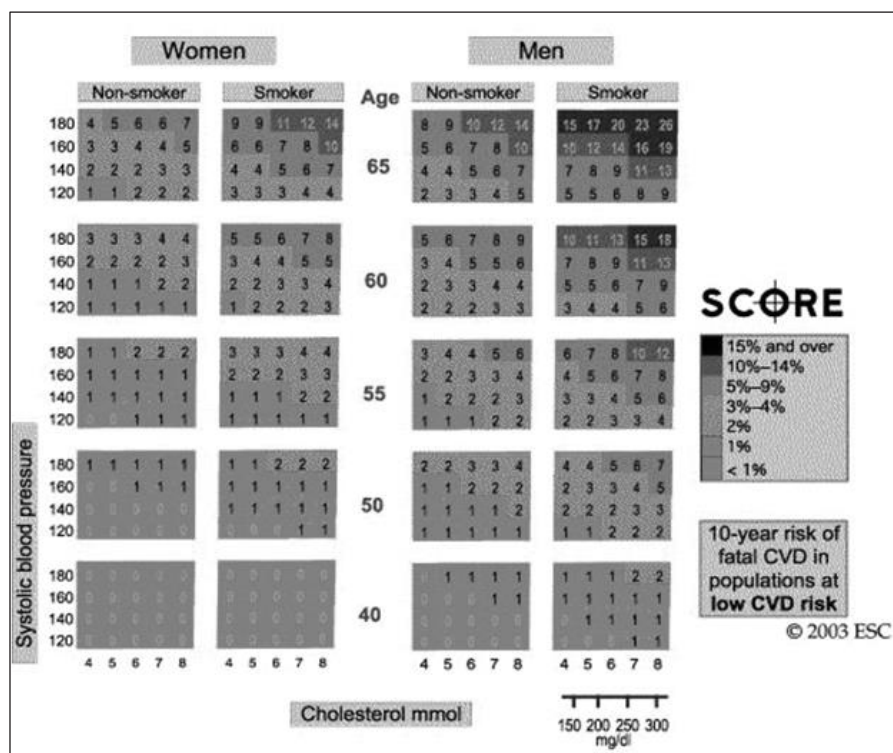

Figure 1. Systematic Coronary Risk Evaluation (SCORE), cardiovascular Risk Charts based on gender, age, total cholesterol, systolic blood pressure and smoking status

using the American Framingham (Massachusetts, USA) study we can create a well circumscribed prognosis of a non-fatal cardiovascular attack in the population or single persons. The risk assessment tool below uses information from the Framingham Heart Study to predict the person's chance of having a non fatal heart attack in the next 10 years. This tool is designed for adults aged

20 and older who do not have heart disease or diabetes. Since 1948(!) the subjects have continued to return to the study every year for physical examination and blood tests (nowadays ultrasound of the heart & arteries, bone densitometry, heart & brain CT or MRI). Since the 1990s the studies have documented a strong correlation between cardiovascular diseases and osteoporosis in special laboratory tests (homocystein, CRP, uric acid etc.)

Using these kinds of early and sensitive markers we can calculate the personal risk profile: A small cardiovascular risk means under 15% Framingham and under 4 SCORE percent, and we talk of high risk above 20% Framingham and above 5 SCORE percent.

In October 2011 a new model was prepared from fresh data and was launched at the 2011 EACTS meeting in Lisbon. The model is called EuroSCORE II - this online calculator has been updated to use this new model. It calculates the renal impairment, the extracardial angiopathy, the poor mobility, previous cardiac surgery, chronic lung disease, endocarditis, critical preoperative status, diabetes on insulin, cardiac and operation related factors. using the

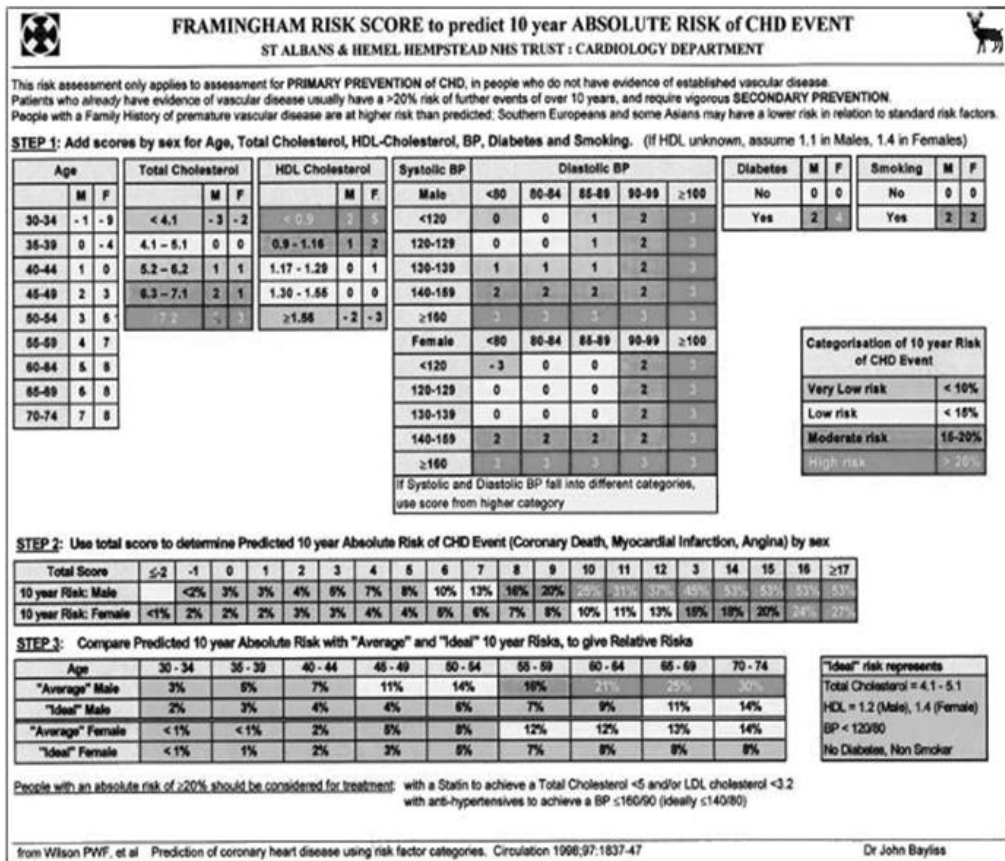

Figure 2. The Framingham cardiovascular risk core

Summary

The cross disciplinary nature of cardiovascular disease needs strong cooperation between a lot of medical specialties in prevention, treatment and rehabilitation. This kind of cooperation must create interdisciplinary teams of academic staff from the basic sciences, together with clinicians in cardiology and stroke therapy also visiting experts in the field of cardiovascular prevention and rehabilitation. The delivery of modern health care depends on groups of professionals and paraprofessionals coming together as cardiovascular teams, who systematically provide personal and population-based preventive care and service to the entire society. Preventive care refers to measures taken to prevent cardiovascular and other diseases, rather than treating their symptoms. The term cardiovascular preventive care contrasts in method from curative medicine, and works at the level of population health rather than individual health. Preventive medicine deals with a healthy population where the costs need even more careful examination and application. For an intervention to be applied widely it generally needs to be affordable and highly cost effective.

This paper was supported by the János Bolyai Research Scholarship of the Hungarian Academy of Sciences.

References

- ANDERSON, K. M. et al. (1991): An Updated Coronary Risk Profile. A Statement for Health Professionals. In: Circulation. 1991;83:356-362. [PubMed] <https://doi.org/10.1161/01.CIR.83.1.356>
- CONROY, R. M. et al. (2003): Estimation of ten-year risk of fatal cardiovascular disease in Europe: the SCORE project. In: Eur Heart J. 2003;24:987-1003. [PubMed] [https://doi.org/10.1016/S0195-668X\(03\)00114-3](https://doi.org/10.1016/S0195-668X(03)00114-3)
- FERRINAND, K. C. (2005): Managing cardiovascular risk in minority patients. In: J National Med Assoc. 2005;97:459-466.
- FLETCHER, G. F. et al. (1996): Statement on exercise: benefits and recommendations for physical activity programs for all Americans: a statement for health professionals by the Committee on Exercise and Cardiac Rehabilitation of the Council on Clinical Cardiology, American Heart Association. Circulation. 1996;94:857-862. [PubMed] <https://doi.org/10.1161/01.CIR.94.4.857>
- Népegészségügyi Jelentés 2003., Johan Béla Országos Epidemiológiai Központ, Budapest.
- ROQUES, F. et al. (1999): Risk factors and outcome in European cardiac surgery: analysis of the EuroSCORE multinational database of 19030 patients. Eur J Cardiothorac Surg. 1999 Jun;15(6):816-22; discussion 822-3.
- ROQUES, F. et al. (2003): The logistic EuroSCORE. In: Eur Heart J. 2003 May;24(9):882-3. [https://doi.org/10.1016/S0195-668X\(02\)00799-6](https://doi.org/10.1016/S0195-668X(02)00799-6)

Prevention of the cardiovascular diseases – with natural antioxidants

KóróDI Gyula MD¹

Cardiovascular diseases are the leading cause of death worldwide. Non-fatal cardiovascular episodes suffered by hundreds of millions of people present an enormous burden even on the most developed health care systems. The amelioration of the mortality and morbidity of the working population has a tremendous economic impact. The increase of the life expectancy at birth by 10 percent could result in a 0,4 percent GDP growth in the economy. With early detection of the risk factors of cardiovascular episodes and with normalization of risk factors we can find a more effective method for preventing cardiovascular disease.

Keywords: cardiovascular diseases, oxidative stress, natural antioxidants, risk estimation

The Hungarian cardiovascular data

Hungarian cardiovascular mortality and morbidity statistics show a significant backlog in comparison to the similar European statistics. The life expectancy at birth has grown by 3 years in the last two decades (in truth the growth was realized only in the past 5 years) in Hungary. In the meantime the higher European life expectancy at birth has risen almost 5 years and Hungary has only passed the Baltic States in this ranking.

The picture is even worse when we consider the disability adjusted life expectancy (DALE), that is the measure of years lived minus an estimated percentage for each year lived in incomplete health. Hungarians are 8 years behind their European counterparts regarding the DALE statistics and again are only above the Baltic statistics.

In more than half the cases the leading cause of death is cardiovascular disease. It is worth analyzing premature mortality (mortality under the age of 65) because this affects the working population and therefore the productivity of the economy. The number of premature mortalities due to cardiovascular diseases in Hungary is 2,5 times higher than in the European union and again only the Baltic states have worse statistics. The scary phenomenon is supported by a survey run among middle aged people that found 40% of respondents say they have cardiovascular disease.

Numerous risk factors for cardiovascular disease are known. Most of them relate to lifestyle (smoking, excessive alcohol consumption, bad eating habits, inadequate physical activity), but other risk factors like environmental factors, genetics, or geographical differences in access to a health care system could significantly influence mortality and morbidity.

1 Quatos Ltd. Email: korodigy@freemail.hu

Early detection of the risk factors of cardiovascular episodes

With the result of our scientific research my goal is to *invest* in an area that evidently promotes economic development and increases economic competitiveness on the long run. In the meantime the investment will cut social and health care expenditures and even create new jobs. My aim is to launch such a public health program that could indicate cardiovascular diseases in earlier stages than we do now and could effectively influence cardiovascular risk factors before the onset of cardiovascular symptoms. As a result we could suppress the development of cardiovascular diseases and could help the unfavourable mortality and morbidity statistics of the Hungarian population.

Research and clinical observations show that in the first stage of cardiovascular diseases – in the process of endothelial damage – the oxidation of lipids is one of the most important factors. The “French Paradox” was described in the 1990’s and it observed the phenomena in France where cardiovascular mortality was significantly lower than in similarly developed countries. The phenomena were explained by the high volume of polyphenol type anti-oxidants found in red wine.

Following the above logic I am planning to follow-up the oxidative stress stage in patients with multiple cardiovascular risk factors (smokers, obese-, hypertensive, diabetes patients and patients with elevated blood lipid and cholesterol levels). My first goal is create a simple and cost-effective method to detect “*Total Antioxidant Status (TAS)*” from blood and urine. This method should enable us to measure TAS in large populations and therefore I can follow the effectiveness of treatment and the effectiveness of *preventing* cardiovascular episodes in the risk population. The currently used TAS measuring system (expensive and not cost-effective for public health screening) will serve as a control method to validate the accuracy of our

measurements from serum and urine samples.

Mostly the LDL-cholesterol fraction of blood lipids, specifically the oxidated type can be blamed for the endothel damage that is the onset of atherosclerosis. In summary I am aiming to develop a method that is able to simply and cost-effectively measure the oxidated serum LDL-cholesterol level. The elevation of serum homocystein concentration could be an early indicator of cardiovascular episodes. Measurement of serum homocystein is costly and the availability is limited therefore it is not widely used in clinical practice. I am planning to develop a simple, fast and inexpensive method to measure the serum homocystein level.

Normalization of risk factors to prevent cardiovascular episodes

The introduction of the above measuring methods in daily screening routines would result in an earlier and more sensitive prognosis in the risk of cardiovascular episodes. A shift in the focus from therapy to prevention could be observed even in Hungary. More effective screening methods and more focus on workplace health could open up new routes to prevention, where the use of healthy nutrition, dietary supplements and health-centered lifestyle enjoy increased emphasis besides pharmaceuticals.

Polyphenols derived from grapes have several observed cardiovascular effects. With the careful evaluation of antioxidants, the impact of these molecules is clearly recognizable on cellular and tissue levels. The action of antioxidants is generally comprised of the capture of free radicals. As a result antioxidants have a cardio-, neuro- and tumour protective function. Widely known facts are that environmental, lifestyle factors and diseases could diminish the resistance of the human body against free radicals. The natural protection of the human body could be ameliorated with a supplement of antioxidants from an external source. Almost all vegetables contain significant amounts of antioxidants but in the skin and seed of blue grapes there are an enormous amount of

Kóródi Gyula Md: Prevention of the cardiovascular diseases – with natural antioxidants

antioxidant polyphenol derivatives. With various isolation techniques the molecules could be separated and with a linear accelerator the electron donor (antioxidants) capacity could be determined. We could rank the antioxidants with the previously mentioned methods and could *isolate the most potent antioxidant molecule*. Various antioxidant molecules could be evaluated in combination to test for synergic or cumulative effect. Through these methods the most potent molecules and their combinations could be further tested to maximize the preventive and therapeutic usage.

The skin and seed of red grapes contain the most amount of polyphenol. High concentrations of polyphenol still remains in grapes (the squeezed form of grapes in vintage) and even in the remnant of the distilled grape (polyphenols are heat stable molecules). My goal is to *develop a dietary supplement* from the "remnant" of the distilled grape by taking advantage of its organoleptic and antioxidant features. "Functional foods" could be produced with the usage of this 100% natural admixture in the meat, milk, mill and spice industry. Eventually, the above food product line could be well used in society to prevent cardiovascular diseases.

Red grape extracts are in commercial use these days, but the effectiveness of these products has not been scientifically tested either "in vitro", nor "in vivo" researches. Based on our tests run in the past years we judge that a research program is needed and rational that could synthesize the above clear goals into a cross-disciplinary system comprising basic research, applied research, technology development and public health. The project would like to screen the oxidative stress status, as a significant cardiovascular risk with sensitive screening methods in an earlier stage and thus prevent cardiovascular diseases with dietary supplements and functional (contains anti-oxidant admixtures) foods, something akin to a "non-alcoholic French paradox". The developed new generational supplements and admixtures would be made out of the Hungarian blue grape. The physical-, chemical-, and biological examination of molecules derived from the isolation of grape polyphenols could result in higher efficiency, a controlled composition food supplement, and admixtures with various economic availability. Finally, the isolated polyphenols could possibly be the basis for future pharmaceutical research.

We could derive data from basic research in regards to the antioxidant capacity of grape polyphenols and the scientific evaluation of its biological efficiency. We could develop new generational antioxidant food supplements based on the results of the basic research findings. "In vivo" testing could result in a useful preventive and therapeutic product against diseases that are accompanied by oxidative stress (like cardiovascular). Finding a method that measures antioxidant capacity in blood serum and urine could be a widely used public health screening method. Marketable food supplements, admixtures, the development of functional foods and incidentally pharmaceutical products could be a result of the project. The wide distribution of these products with the above scientific background could improve the health status of society.

Summary

The exploitation of these possibilities and the expected economic results of the project are the following. This project makes top priority among R&D targets the improvement of life quality and the prevention of cardiovascular diseases (the leading cause of death). The goal of our scientific research work is to implement continuity from basic and applied research, technological innovation to the initiation of our products on the market. The proposal has a clear objective, for its achievement a complex approach and the cooperation of several technological areas is necessary. This is mainly valid for medical, physical and chemical areas that should be supported by such indispensable elements like creativity and productive

experience.

The conformity of the project proposal clearly suits the objectives of the program, it contains internationally acceptable scientific consequences and given intellectual products with new technologies, equipments, furnishings and materials. The collaboration of a small enterprise with research units of the Hungarian Academy of Sciences and the leading medical research institutes of Hungary can produce original results for preventive medical practice.

One of the basic objectives of our work is to clear up the biochemical aspects of the risk factors of illnesses demonstrated by medical investigations. We would like to create a national health-care program based on early diagnostic and preventive therapeutic possibilities to improve the morbidity and mortality rates. The new method can indicate the “oxidative stress” in an early stage, and the “functional food-products”, food-supplements, (pharmaceutical products) can treat it effectively and reduce the cardiovascular mortality.

This paper was supported by the János Bolyai Research Scholarship of the Hungarian Academy of Sciences.

References

- AHERNE, S. Aisling – O'BRIEN, Nora M. (2002): Dietary flavonols: Chemistry, food content, and metabolism. In: *Nutrition*. 18. p. 75-81. [https://doi.org/10.1016/S0899-9007\(01\)00695-5](https://doi.org/10.1016/S0899-9007(01)00695-5)
- BIRÓ György – DWORKSCHÁK ernő – ZAJKÁS Gábor (1997): *Élelmiszerek az egészségmegőrzésben*. Budapest, Béres Rt. p. 113.
- HALLIWELL, Barry (1996): Antioxidants. In ZIEGLER, Ekhard E. – FILET, L. J. Jr. (eds.): *Present knowledge in nutrition*. 7. ed. Washington D.C., ILSI Press. p. 596-603.
- HENNEKENS, Charles H. (1998): Antioxidant vitamins and cardiovascular disease: Current knowledge and future directions. In: *Nutrition*. 14. p. 50-51. [https://doi.org/10.1016/S0899-9007\(97\)00393-6](https://doi.org/10.1016/S0899-9007(97)00393-6)
- LÁSZLÓ Valéria – FALUS András (2002): Az öregedés sejttani és genetikai alapjai. In: *Magyar Tudomány*. XLVIII. p. 406-411.
- LUGASI Andrea (2000): Az élelmiszer eredetű flavonoidok potenciális egészségvédő hatása. In: *Orvosi Hetilap*. 141. p. 1751-1760.
- NIJVELDT, Robert J. – NOOD, Els van – HOORN, Danny E. C. van – BOELEN, Petra G. – NORREN, Klaske van – LEEUWEN, Paul A. M. van (2001): Flavonoids: a review of probable mechanism of action and potential applications. In: *American Journal of Clinical Nutrition*. 74. p. 418-425.
- WAHLQVIST, Mark L (2001): Principles in the development of novel and functional foods. In: *NAFAS Science*. 4. p. 31-35.

Changes in Concept of the European Policy of Roma Integration

HAID Tibor¹

The success of the social integration of the Gipsy population is one of the basic conditions of the common European future. However, the direction of the efforts has been proved to be maladjusted. For being able to concentrate the resources restricted by the economic crises, a modification of concept has been deeply needed. Instead of focusing on anti-discrimination policy, the areas of a real effective governmental intervention must be determined. Elaborating the framework of the common European Integration Strategy of Gypsies, the Hungarian presidency aimed rather at social and educational issues, which gave a sign of a new approach to the topic.

Keywords: anti-discrimination, changing of concept, Gypsy/Roma, integration, strategic framework

Introduction

The actual economic and financial crisis has brought to light, one by one, the internal contradictions threatening the European union and their explosion. A thorough and consequential examination of this phenomenon points to the same deficiency. The alliance of the European states originally established as an economic organization has been widening and deepening with the joining of new member states. Although the cooperation has become more and more tight and close, it has also revealed the question of the social legitimacy of this widening common regulatory body. The accelerated enlargement of the union has resulted in the incorporation of societies which are divided by social tension not known in the original “core” member-states before, and which differ from the original Western European member states in regards to historical background, economic capacities and social identity as well.

The process of integration having just started after the enlargement seems to halt or even to stop forever because of the crises. But the main reason for this stop in the procedure of integration is not the shrinking amount of the allocated financial support. This factor might have sped up this break down, and has also made it impossible to delay facing and estimating the deficiencies of the base of the union which are mainly not economic but rather moral and cultural by nature, and have been swept under the carpet before the crises.

The harsh debates during the slow process of the elaboration and promulgation of the Common European Constitution already revealed – even at the level of political declaration - the lack of common cohesive values (with the exception the old glue composed of some partial but still strong common economic interests), and which mental factors are stipulated to be the base of integration in the social sub-systems. However, it seems to be evident that the European union should cooperate in a closer and more efficient way. However the commonly accepted ideal figure of the

¹ Email: haid.tibor@chello.hu

European Citizen, the ideal individual that is supposed to make the common economy function and prosper has not appeared yet. But without a common European identity, a long-term cooperation is impossible. On the one hand, it seems to be unimaginable to have a system of reallocation that supports and is advantageous and satisfactory for all participants. The highly intensive cooperation needed to become economically competitive also involves the partial delegation of some factors of national sovereignty by the member states to the common bodies and organs of the union. This legal action can not purely derive from the actually coinciding economic interests of the member states. On the other hand, only those societies can survive the periodically appearing economic crises without the risk of disintegration, which possess a common moral creed. This social treasure is necessarily based on the impression of community, in our case it should be the common European identity.

Studying the situation of the Gypsies who are estimated as the most numerous ethnic minority group within the boundaries of the European union, the lack of the common European identity is so evidently visual that the phenomenon even poses doubt as to the possible success of the actions aiming to found a mental base of the alliance at any time in the future. It is difficult to assert that the Gypsies - whose first groups were noticed present in the Balkans as early as the beginning of the 11th century and by the 15th century arrived in the central areas of the continent - should not be as at home in the European present and past as any other nation looking back with a thousand-year-old presence here. Nevertheless, they are still surrounded by an atmosphere of being odd or even alien, and if numerous groups of them appear somewhere they usually raise irrational fears among their hosts.

you can easily get the well prepared and ready to use ideological explanations for the reasons of this phenomenon on the market of intellectual products. In the main stream, the problem seems to derive from the original sin of approaching with

preconceptions. Nowadays the more refined version of the doctrine - blaming the stereotyped mindset for the majority of social problems - is also available. The key word "prejudice or stereotype" has not lost its shine but it is not necessarily the exclusive possession of the majority any more, a minority group can also have prejudices against other social groups as well. The idea of blaming prejudice does not consider the fact that there is no alternative way of thinking which does not contain the stereotyped approach of getting knowledge, and can be followed by the vast majority of the society. Human cognitive activity is restricted both in time and in space. But the interest stimulating us to gather knowledge about our social and natural surrounding also urges us to close the contemplative phase as soon as possible with a practically useable outcome. So in a nutshell, the majority society rarely gets information just for being curious, without keeping a specific – not surely known – aim in mind, but we want to find the common rules of mechanism which function or – talking about social phenomena – motivate the huge diversity of experience and actions (behaviours). We are eager to know "what makes the world go round" and use the rule in our personal life, for our own interest. And we share what we have gained according to our familiar, social, ethnic, religious, professional etc. connections to help our group-mates to spare the time and energy of searching and studying on their own. And we are mutually keen on accepting the rules defined by other individuals and credible people – especially the rules supported by some little pieces of personal experience – rather than choosing the odd and tiring way of creating new ones. Accepting the rules provides us comfort and the atmosphere of safety, sharing those works as a cohesive factor in the group and helps the members to cooperate.

Those who follow the doctrine of blaming prejudice normally do not consider that the common opinion derived from generalised experience that becomes a part of tradition can only be deprived of its acceptance by individually felt experiences which are strong enough to destroy the contrast-

ing previous opinion and even to make the individual share the changed idea. But automatic refusal of the conclusions drawn and generalised from real experience – or even the direct or indirect reprisal of the publication of these conclusions – leads to superficial adaptations of the main stream and hides the real opinion.² The manner of scourging the common opinion of the social majority because of its prejudice also sends the message that instead of drawing the conclusions of experience you should accept in public only the ideas of the main stream intellectuals, otherwise those who confess their different opinion will lose their credibility, risk the possibility for publication and finally find themselves at the periphery of public life.

The view detailed above dominates public opinion, even nowadays; it is rather counter-productive. On the one hand it produces frustration by forcing people to accept the ruling intellectual opinion, even in those cases when it contrasts with the result of the evaluation of personal experience. Speaking out on social problems sincerely in public is usually the first step on the way to solving them. If you feel deprived constantly of this possibility, it usually arouses indifference or even hatred against the whole topic, without any distinction among the social group protected by the muzzle of political correctness.

On the other hand, it gives the unique taste of "forbidden fruit" to the other old and wide-spread common opinion, which is quite different in its attitude but not less dogmatic in its approach, depicting Gypsies mainly as the source of many social problems. The evident difficulties in social integration of this minority group are explained by their unchangeable character and behaviour³, leading to the conclusion that supporting their integration is only a waste of time, money and effort. Consequently, measures at a societal level should not be made for them, but against their effect, as a social self-defending activity for the interest of the majority.

The source of the theory of the unchangeable character of certain ethnic groups can be disclosed in the school of thought of Social-Darwinism, which appeared as one of the most modern approaches to understand the different level of human civilizations, applying the idea of evolution to the social sciences, and also as an optimistic justification of the white intrusion into the less (or un-) developed parts of the world with a mission of spreading the benefits of Western civilization.

Both the supercilious snobbism of social engineering, which detects only primitive prejudice in the fears and antipathy of the majority of the society, and the opposing effort to form an identity out of these negative experiences, fears and contradictions, evoke the image of "bilateral social behaviour" described by István Bibó, already in 1949. as they are "totally dehumanized because they are based on nightmares or survived hurts and sufferings, or unjustifiable feeling of honour and rank, or causeless inferiority complex."⁴ Both attitudes detailed have a lifeless dogmatism as a common alienating feature, so both of them affect harmfully the minority group and its relationship with the other parts of the society.

We should regard the minority issue in the European union and the above mentioned opposing attitudes as the spiritual background to when the first groups of Central and South eastern european Gypsy immigrants appeared in the West, in the years just before the enlargement of 2004. Searching for some residuary advantages of the welfare state, on the wane, they also made the core part of europe face the deficiencies and doubts of its basic values. Several campaigns have been launched based on previous social surveys since the historic enlargement of 2004. But the success

2 More details can be found about the hiding of opinion in: SZABÓ (2008)

3 According to the survey conducted in the first decade of 2000's, it seemed to be firmly widely accepted that Gypsies are not able to follow the general social ways of life because of their "genetically coded different manners". GyIMESy–NAGy (2008)

4 SZABÓ (2004) p. 240.

seems to be delayed. One of the clues for breaking through is the reconsideration of the concept and practice of basic human rights with a new approach of minority and anti-discrimination policy. The economic crises that reached the union by 2009 made it clear for the vast majority of the European citizens that the whole concept of the welfare state has been deeply

involved in the crises. The price of social peace could not even be paid by social support and allocations, if the enlargement had not meant also the arrival of economic immigrants from the new member states and all the social tension caused by them. But the enlargement and the crises soon afterward urged the elaboration of a new concept of social division of labour and the individual rights and obligations, to rethink the idea and practice of positive discrimination with a regard to its collateral social and economic effects, to find a new balance between the individual and collective identity, and to restore the role of state in the public opinion.

As Gypsies are a numerous minority group that consist of linguistically and ethnically hetero- genic subgroups, whose problems of identity are closely related to their existential disadvantages, the Union cannot avoid or delay finding a solution for their integration. But it opens another previ- ous question that has not been solved yet, the lack of a common European identity. As integration of a group of people means finding a suitable place in a larger unity, the first step on this way must be the identification of the unity you are going to be incorporated in to.

The factual presence of Gypsies in Western Europe unwilling to return to the “backyard of the continent” where most of them are from, might catalyse the necessary changing of concepts detailed above even after the end of economic crises.

Gypsies⁵ in an enlarged Europe

80% of the 10-12 million Gypsies living in the European union have arrived in the area and also in the focus of the media since 2004. Mentioning their name evokes a string of associations and worries normally ending in doubts regarding the sustainability of the common European future even among the non-euro-sceptic citizens of the states that have been Eu- members since before

2004. Their simple presence usually works as an evident but not directly uttered argument against any enlargement to the East or South-East in the future.

The problem is not new at all. Just remember the loud echo in the media made by the Gypsy emigrants from Hungary (“romas from Zámoly”), Slovakia and the Czech republic arriving in the West before 2004. The decision-makers, on the extending of the geographical boundaries of the union, must have been alerted by these events to be able to estimate the depth of the social gap be- tween the core part of the continent and the post-communist candidate-states, as well as the weight of the new type of problems – within the ones caused by the existential and social disadvantages of the Gypsy population – that arrived together with the historic enlargement.

Between 29th June – 1st July 2003. a regional conference took place in Budapest with the title : “romas in an enlarging Europe. The challenges of the Future”. The meeting of the heads of state or government of Bulgaria, Croatia, Czech republic, Macedonia, romania, Serbia (together with Crna Gora – Montenegro at this time), Slovakia, and Hungary as the host country, was organised

5 Here I would like to explain why I use the world ”Gypsy” instead of roma, romi...First of all, possessing one’s own name, used by the surrounding nation means a certain level of acceptance ,or at least a long coexistence. using a self nomination instead of avoiding some unpleasant connotations or associations also deprives this minority of the atmosphere of being a tome in the language. I should also note, that the word ROM, ROMI, ROMA is not generally accepted among the Hungarian Gypsies, as the most numerous group of them, the only Hungarian-speaking Gypsies, do not define themselves as Roma, but Gypsy or Romungro.

by the Institution of Open Society and the World Bank. The participants declared the 10-year- peri- od 2005-2015 as the Decade of roma Inclusion.

At the sessions on 16thNovember 2004, held in Budapest the participants accepted and signed the Declaration of the Decade of roma Inclusion, aiming to stop the discrimination of romas and to surmount the social gap between them and the other parts of the societies. They planned to achieve these goals by studying and analysing the experience gained during the realisation of the Action Plan for the Decade, with the assistance of Gypsy communities and by the initiation of other states in the project. In Sofia on 2nd February 2005. the Programme of the Decade of roma Inclu- sion (hereinafter: PDRI) was officially launched with ceremonies. The PDRI was promulgated in Hungary on 19th May 2005.

The PDRI links the aim of social and economic integration of Gypsies with the purpose of advocat- ing a more positive public opinion about them. The participant countries elaborate their own national roma Strategy coordinating the commonly accepted aims with their own social and economic policies.

The participant states of PDRI have two direct obligations. Each of them is bound to elaborate a national action plan as a schedule of the realisation of the national strategic plan that can be con- sidered the state-level application of PDRI. The action plans have 4 common features following the 4 areas of priority of PDRI: all of them must focus on education, health care, employment and dwelling (habitation). They also target to initiate as many members of the Gypsy intelligentsia as possible, both at the level of planning and realisation. The other obligation is establishing a mon- itoring system to follow the execution of action plans by gathering, analysing and forwarding the relevant data and information. The monitoring system can also function as a tool to re-plan the route and even to modify the destination.

The year of Hungary in the presidency of PDRI

Hungary assumed the presidency of PDRI on 1st July 2007 for a year. Erecting its priorities, the

Hungarian leadership could use the experience of the previous Bulgarian period of the presidency.

Keeping in mind the acceleration of the process of enlargement of the union and also the constant presence of Eastern European Gypsies in the Western member states, the Hungarian presidency wanted to increase the number of member states of PDRI, inviting Bosnia, Moldavia, Portugal, Spain, and Slovenia into the framework of PDRI-cooperation. Hungary also initiated that the common institutions and bodies of the union put into their schedule the discussion of PDRI with the aim of elaborating a unified European Roma Strategy.

The Hungarian presidency also emphasized the importance of corporate social responsibility (here in after: CSR) as a new priority of PDRI. They also launched a communication campaign to inform the vast majority of European societies about the living conditions of Gypsies. They established some groups of experts with the task of finding possible solutions to eliminate the segregation of Gypsies in the areas of dwelling and education. Finally, the Hungarian presidency also wanted to develop the monitoring system introduced by the previous Bulgarian period of leadership.

The CSR-concept is based on the idea that the actors of the economy voluntarily incorporate some social and environmental values and approaches in their business policy and that they even represent this towards their partners. According to the CSR-idea companies are supposed to realise that the social and environmental side-effects of economic activity risk sustainable development, so - following their long term interests in business – they voluntarily adjust their mindset from the points of view originally incompatible with the narrow way of thinking of a competitive market economy, otherwise the whole social and economic system will collapse, burying the market where

they gain their profit. The CSR-concept also supposes that the idea of sustainable development has already been accepted by the vast social majority; consequently the additional costs of CSR-activities should also be recovered in the short term because of the PR-advantages that companies with positive and responsible social and environmental attitude would gain.

The Hungarian presidency raised the CSR-issue regarding the Roma Inclusion. Companies might start up a system of scholarships with the aim of eliminating the disparity of qualifications of Gypsies, involving long-term educational programs for adults who dropped out of public elementary education and also short-term training for those who have basic skills but still need a more market orientated qualification. The theoreticians of CSR also suggest inserting some methods of direct or indirect positive discrimination in the field of employment. Providing better chances for Gypsy candidates for a job is an example for the first item, as supporting legal consulting offices granted the minority a way of indirect positive discrimination. As a part of CSR, the elite of business life are supposed to support Roma inclusion by sponsoring cultural events and by making Gypsies appear in a positive light – as the “good guys” – in advertisements. All of these were planned to be a part of comprehensive national CSR-strategies.

During the Hungarian presidency the issue of a Common European Roma Strategy was propounded. The common strategy was planned to be a good tool for the more efficient enforcement of interests, a higher efficacy of sponsored social programmes, a solution for the problems of economic migration and also for accelerating the social integration of Gypsies. The theoreticians pointed to the poverty, the uncertain view of the future and discrimination as the reasons for the economic migration. They marked as patterns those that still exist in European frame strategies of anti-discrimination regarding the inequality of sexes, handicapped people or immigrants.

The Hungarian presidency put the policy of anti-segregation in the central position of the frame strategy, because it was considered a way of avoiding the conservation of the multiple disadvantages of Gypsies in the area of education and accommodation.

Segregation in dwelling means partly undeveloped districts with low level and crowded living conditions – ghettos – within the boundaries of a community, and it can also appear at regional level, as in the areas of slow (or no) economic improvement, where the ethnic proportions of the population normally change dramatically, resulting in permanent or even deepening disadvantages in infrastructure and employment. The elimination of segregation in the area of accommodation was mainly hoped from the success of proposed programs of building social tenement-dwellings but it was also combined with other integrative programs in the field of education and employment.

As well as in the area of dwelling, the segregation in education appears in different levels from special Gypsy-classes within the same school, to schools exclusively for Gypsies and non-Gypsies. To discontinue the practice of segregation in the field of education, the Hungarian presidency proposed to introduce pedagogical programs for developing the abilities of pupils, widen the chances for further studies and try to decrease the tendency of dropping out of the school system after basic education. They also planned to elaborate a pedagogical framework of unified and comprehensive standards and methods with the aim of discontinuing educational segregation.

Both for advertising the European Roma Strategy and for achieving its goals a communication strategy was highly needed. Reaching the decision-makers, media-experts and the youth between

18-35 as the target groups was the strategy, the theoreticians wanted to influence the whole of society, to make it accept the existence of PDRI and also to make them change their opinion and attitude regarding Gypsies in a more positive direction.

The first traces of conceptual changes in European Roma inclusion policy

By the time Hungary took over the presidential duties of the union on 1st January 2011, it had already been clarified that the measures and plans introduced in the hope of enhancing the integration of Gypsies had not brought enough results. The

riots of starvation in Eastern Slovakia in

2008-2009 already had a quite strong ethnic feature, and a string of criminal cases in Hungary at the same time was even more closely related to both the victims' and the committers' ethnic origin. Just remember the case at Olaszliszka, another murder in Veszprém committed by Gypsies, and the series of violent crime – mainly murders – against Gypsies, in both groups of cases the perpetrators were intensively motivated by ethnic reasons. It became evident for the vast majority of Eastern European citizens, that the ethnic tension partly deriving from the economic-existential situation was leaving the well known path of crimes against property.

In the autumn of 2010, in France, authorities had to close down illegal Gypsy settlements. As the procedure took place in the cradle of European democracy, it caused great media-excitement and made the intellectuals reopen the tin of ideas stored since the arrival of Gypsies from Zámoly to Strassbourg. But it was felt, for the first time that something had already changed in the public opinion regarding the minority issue. Now the determined and firm – but not cruel, nor antihuman – governmental measures were followed by sympathy and met the expectations of the majority of the French, only a loud minority were crying the wolf call of racism.⁶

Since the phenomenon was strongly related to economic migration and effected the whole union – within the more influential core-member-states - the european community urged the Hungarian presidency to find a quick and effective solution. Hungary, which as a country has a lot of experience of both coexistence with a relatively numerous Gypsy population and also state sponsored measures (positive and negative as well)⁷, had to elaborate the basic principles and framework of the new common European roma inclusion plan, the European roma Strategy.

After the precedents detailed above, the European Commission accepted on 5th April 2011 its Communication (here in after: Communication) as the European union framework for national roma integration strategies up to 2020.

The Communication declares that improving the situation of the Gypsy population is a social and economic imperative both for the union and its member states. It also stated that the 10-12 million roma population facing prejudice, intolerance and discrimination live in very poor socio-economic conditions, which is not tolerable in the union at the beginning of the 21st century.

According to the Communication, the elimination of their marginalisation is a part of the Europe 2020 strategy, which is described as a basic plan for a new growth path. It is very important to emphasize as evidence of a change in concept that according to the Communication the social and economic integration is a two-way process, urging both the majority of the population and also the Gypsies to change their mindsets.

The Communication outlines the primary responsibility of the public authorities of member states for the measures needed to eliminate discrimination and to provide the necessary conditions for the practical realisation of equality before the law. But – as another trace of the change

6 The Hungarian Kossuth radio broadcast a discussion with interpretation between Arnaud Montebourg – who wanted to emphasize the racist character of governmental measures – and Pierre Lellouche – the minister of European affairs and Brice Hortefoux – the minister of internal affairs - on 20th January 2011 in the program "Jelfogó". The simple sentence of Pierre Lellouche: "A free airplane ticket home, to another union member state and the transportation to the gas-chambers have absolutely nothing in common" sounded like a real ideological breakthrough.

7 BÁRSONY (1997) p. 319–332.

of concept – positive discrimination cannot be found as an obligatory practice of the states. So in a nutshell, the key is a world of equality and anti-discrimination but not positive discrimination, which is a significant modification of approach. The document also calls the attention to another change pointing to the potential economic advantages of integrating Gypsies into the labour market. Instead of claiming social assistance they would pay tax from their income, a fact which itself can strengthen the social cohesion between this minority groups and the majority of the society.

The Communication mentions that efforts have already been made both by the member states and the union, but outlines that – in spite of them - only little has changed in the daily life of Gypsies. That is why the document urges the member states to adjust their roma integration strategy to the EU framework, and also harmonise the roma integration policies with other strategies against poverty and exclusion. This new concept is supposed to increase the effectiveness of national roma integration strategies and also diminish the indirect discriminative effect, not excluding other groups suffering from poverty, inequality and exclusion.

The Communication sets the main goals of the roma integration, which are quite similar to the ones of PDR I. These are the access to education, employment, healthcare and housing and essential services.

Among these crucial areas the Communication mainly deals with the goal of access to education, underlining the minimum aim ensuring that all roma children complete at least primary school. The document also emphasizes the importance of eliminating segregation and other forms of discrimination in education. As a new element, for those who are still above the compulsory school-age but have dropped out of primary school without having finished, the document encourages "second chance programs" for enabling young adults without a complete primary education to get this minimum qualification, enabling them to enter into the labour market or even further education. It also highlights the importance of participation in early childhood education and care as a tool for overcoming the educational disadvantage. For achieving these goals the Communication underlines the key role of churches, religious associations and school mediators who can help Gypsy parents in understanding the importance of organised education. Mediators should advise parents on the local education system and help children in the transition between each stage of their school carrier. This kind of mediation is

especially important for non-sedentary Gypsy children. As a part of this two-way process, the document urges reform of teachers' training curricula and to elaborate innovative teaching methods for enabling teachers to tackle the special needs and difficulties which they may face.

Regarding the access to employment, the Communication underlines the significant gap between the employment rate for Gypsies and the rest of the population. To reduce it, the document suggests granting Gypsies full access to vocational training and - after getting the needed qualification - to the job market, in a non-discriminatory way. In terms of education, there are two other methods mentioned. On the one hand, a micro-credit system the self-employment should be encouraged, on the other hand in the public sector qualified Gypsy civil servants should be employed, if it is possible.

In the field of healthcare there is a significant disadvantage suffered by Gypsies, which is clearly reflected by their life expectancy being 10 years less than the majority and a much higher child mortality than the general population. The Communication denotes many reasons for it, one of them is discrimination in the access to healthcare. But the others - poor living conditions, lower presence in information campaigns, exposure to higher health risks - seems to have more importance. In linking the Gypsy population to the healthcare system and encouraging them to more frequently have - partly preventive - visits, qualified Gypsies have a key role.

Regarding dwelling, the Communication emphasizes the much poorer access to public utilities (water, electricity, gas). There is the special problem of non-sedentary Gypsies who rarely find sites with enough access to water. The suggested solution of the problem is promoting non-discriminatory access to social housing and also special attention to the needs of non-sedentary Gypsies.

The Communication urges member states to elaborate comprehensive and coordinated strategies of roma integration on the base of clear policy commitments regarding the four areas mentioned and detailed above. Therefore the member states should:

- set achievable goals in the four areas of priority with realistic minimum standards,
- identify the most disadvantaged regions and segregated areas,
- allocate funding from national budgets, which can be completed by international and union support
- introduce and apply an effective monitoring system to evaluate the needs and achievements
- build up a system of close cooperation and dialogue with Gypsy civil society, regional authorities and non-governmental organisation, churches involved in the issue.

The Communication emphasizes the responsibility of member states, but also urges them to involve competent civil organisations and churches with relevant information on the needs and a living relationship with Gypsy communities. With their help public administration can spare the task of detecting the problems.

The Communication combines roma integration with the possible further enlargement of the European union, pointing to the 3.8 million of Gypsies living in Turkey and in the Western Balkans even among poorer conditions than the roma population of member states. The development of their socio-economic situation is an important issue of the negotiations in the joining procedure.

The Communication declares the leading role of the Commission in roma integration, and especially points to the importance of an efficient monitoring system. The Communication ends with an ambitious and imperative conclusion: the situation of the roma population must change significantly within 10 years.

Conclusion

In comparing PDRI and the Communication the change in concept of roma integration seems to be clear. The most important feature of the modified approach is that the policy for the integration of Gypsies has become a common issue for the whole union as one of the highest priorities. It reached an elaborate program which does not exclusively involve the participant states of PDRI where the majority of Gypsies are from.

It is a not a less important achievement that the Communication underlines the Gypsies' own responsibility regarding their integration, leaving behind the one-sided previous approach focusing on mainly anti-discrimination policy.

Giving up the CSR-concept belongs to a wider and deeper change in the perception of the role of the state and non-governmental and non-profit organisations. The idea of optimal auto-regulation by the actors of the market economy ~~seems to be evidently~~ unjustifiable during the crises. Instead of the hope that for-profit companies, following their long-term interests, would effectively regulate economic or even social issues, the urgent need of regulating the market and its actors by the state has become evident. But not only the role of the state - as the most powerful non-profit social organisation -, but also the non-profit civil organisations and churches must be reactivated, because of their original non-profit, non-competitive mindset and approach. There is no reason to be scared of their ideological or religious message either.

Finally, the freshest innovation of the Communication is that it deals with roma integration as a core but not unique part of a bigger social problem, namely the fight against poverty and discrimination in any terms. I suppose that this approach suits more the complexity of roma integration because it does not address the question of assimilation and ethnic identity. As the Gypsy population is not only the most numerous but also the most heterogenic ethnic minority group in the European union, a common European roma integration

strategy cannot be effective if it focuses on this question which is an internal affair of this ethnic group and might be answered differently by each subgroup of Gypsies. restricting the area of activity of public administration to more practical issues is a more realistic approach with more achievable goals.

References

- BALOGH András – OSTOVÁNYI Zsolt – BÚR Gábor – ANDERLE Ádám (2002): *Nemzet és nacionalizmus, Ázsia, Afrika, Latin-Amerika*. Korona Kiadó Budapest.
- BÁRSONY János (1997): *A cigányság és a rendőrség kapcsolatának történelmi összefüggései*. Szöveggyűjtemény a kisebbségi ügyek rendőrségi kezeléséhez. COLPI, Budapest.
- BERNÁTH Gábor (2004): Kitaposott utak. esélyek és esélyegyenlőtlenségek. In: *Társadalom és Honvédelem*. Vol. VIII. No. 1-2. (Roma Special Issue) ZMNE. p. 86–104.
- HetiVálasz: *Nem szokta a cigány (Földprogram – sikerverejtéssel)*. 14 April, 2011 (Vol. XI. No. 15.) GyIMESI Gyula
- NAGY Kálmán (2008): Vélekedések a cigány katonákról. In: *Társadalom és Honvédelem*. Vol. XII. No. 1. (Roma Special Issue) ZMNE. p. 124–137.
- A Magyar elnökség programja 2007. július 1-2008. június 30.* Magyar Köztársaság Szociális és Munkaügyi Minisztériuma, Budapest, 2007.
- SZABÓ A. Ferenc (2004): Roma migráció. In: *Társadalom és Honvédelem*. Vol. VIII. No. 1-2. (Roma Special Issue) ZMNE. p. 237–241.
- SZABÓ János (2008): Romák a haderőben In: *Társadalom és Honvédelem*. Vol. XII. No. 1. (Roma Special Issue) ZMNE. p. 124–137.
- TÓTH Sándor (2004): A magyarországi cigányság a társadalom tudományi kutatások tükrében. In: *Társadalom és Honvédelem*. Vol. VIII. No. 1-2. (Roma Special Issue) ZMNE. p. 214–236.

Experience in the Use of Military Forces in Flood Protection

PADÁNYI József

The tasks of the Hungarian Defence Forces have changed significantly due to the evolving security challenges. While the level of traditional threats has decreased, there are new challenges approaching, which influence the sense of security in society. These are terrorism, the effects of climate change (floods, snow storms) and cyber crimes. To face the risk factors defined in the National Military Strategy we are in need of changes in preparation, in the set of military assets and in the educational framework. As a result, officer and NCO training and education will be transformed too. We are looking for solutions which can raise the security level of our soldiers in domestic tasks and abroad in international missions.

Keywords: Hungarian defence forces, changing security environment, military officer and NCO education, disaster relief, flood protection

Introduction

The changing security environment has had its effect on the duties of the Hungarian Defence Forces. New challenges emerged or intensified, such as terrorism and disasters caused by climate change (primarily floods in increasing numbers and intensity). Decreasing resources make transformation more difficult, whether it is in the field of organisation, military training and education or the modernisation of military assets. By today the tasks have crystallised and transformation, although slowly, has started. The system of officer training will be completely renewed from 2013 on, the reserve officer system will be reorganised, our role in international missions will be restructured and the tasks performed domestically will get more emphasis. Most armed forces face similar challenges, although the place where the emphasis is put, differs. In the following paper we will present the challenges facing the Hungarian Defence Forces and some of the areas of the responses to these challenges with special regard to the role in flood prevention.

International outlook

The use of military forces in preventing disasters has become an unquestionable practice in today's world. This was not always the case, as there were serious disputes whether military abilities can be used for such purposes, even at the end the 1980's. Due to the changes of political and military circumstances and to the discontinuation of traditional conflicts this dispute has quickly come to a rest. On the one hand, a few disasters demonstrated that the application of military forces is indispensable in this field – e.g. hurricane Andrew (United States, 1992) – and on the other hand the traditional enemy disappeared and soldiers suddenly found themselves in a vacuum. Cynically speaking, we could say that a new task came in handy. As a consequence this field got more emphasis in security strategies and military doctrines. Organisational and technical developments

followed, offering more and more ground to multipurpose organisations and assets. We will show a few examples below illustrating the relationship of military forces and disaster prevention.

Switzerland

The Swiss Constitution summarises the duties of the Swiss armed forces in three points:

59

- armed protection of the country's independence and territorial integrity;
- supporting civilian authorities;
- participation in the international support of peace.¹

By "supporting authorities" primarily the support of the police during international conferences and other important events is meant. Military forces may participate in the prevention of disasters when they can quickly provide assistance to the fire brigade, the healthcare and civil defence organisations.

Croatia

Prevention of disasters, support provided to civilian authorities in emergencies and search and rescue operations play a decisive role among the duties of the Croatian armed forces. Because of the circumstances of the country this is mainly

realised in the fight against devastating forest fires. There are 6 pcs AT-802 and 6 pcs CL-415 fire-fighting planes among the assets of the Croatian Air Force that undergo live assessment every year. This was also the case in July 2012 when they participated in extinguishing an extensive forest fire in the region of Selce.²

The Croats put a lot of emphasis on preparation, too. The organisation of the Croatian Armed Forces prepared for fire-fighting makes arrangements for the summer period with exercises. The MI-8 helicopters transport firemen and equipment to endangered points and practise abseil, communication and flying by the seashore.³

Fire-fighting planes practice extinguishing, landing on water and fuelling on the water's surface. They put a lot of emphasis on co-operation with civilian bodies as civilian and military rescue forces have to work together in a relatively small area under extreme circumstances during fire-fighting.

A peculiar task of the Croatian Air Force is ambulance service from islands, principally when flying or transport needs to be performed quickly and under difficult circumstances.

Czech Republic

The major force of preventing disasters in the Czech Armed Forces is a technical brigade. A part of the subunit is expressly specialised in preventing disasters – primarily floods. Their training, assets and command structure are all subordinated to this task. They have demonstrated their skills on several occasions in recent years. Naturally other forces of the Armed Forces can be deployed in disaster situations, such as the transport capacity of the air force or the medical specialists.

Without going into further details of the principles of deployment and experiences of other countries we shall make some references to the principles of military forces' deployment:

- The Canadian government does not use military forces normally in disaster circumstances but if the protection needed is excessive it is possible to deploy further forces and assets.

1 <http://www.vtg.admin.ch/internet/vtg/en/home/themen/auftraege.html> (17.06.2012.)

2 <http://www.focus-fen.net/index.php?id=n283787> (24.07.2012.)

3 http://www.osrh.hr/default_en_news.asp?id=686 (24.07.2012.)

- In Belgium civilian and military players are treated with a consistent attitude in disaster circumstances, as complementary resources. In principle the necessary resources are applied at the appropriate location in the proper time.
- The starting point of the French approach is that military forces must immediately be deployed when necessary thereby reducing damages and losses.
- The British unambiguously stood up for immediately deployable military forces if that seems to be the best solution.

Domestic situation

Legal background

The *National Defence Act* clearly stipulates the duties of the Hungarian Defence Forces.⁴ The most important duty of the Defence Forces is the armed protection of the country. Beyond that the “participation in executing tasks related to disaster management” is a decisive and – as experience has shown – very frequently occurring task. The requirements of this task also appear during the development of the army. When performing disaster management duties military organisations participate in it under a military chain of command system, under the leadership of their own commanders. When doing so the Chief of Staff decides on deploying a maximum of 200 persons for a period not exceeding 21 days; for deployment more than this number of personnel or for a longer period the minister responsible for defence is obliged to make a decision. For deployment exceeding 3000 persons the minister responsible for defence informs the committee of the Parliament dealing with national defence issues, concurrently with the related decision. It can be seen that the task is performed in a clearly defined order and way.

When formulating the duties the National Defence Act puts special stress on those expectations of the society that serve the direct support of the civilian environment. Thus the duties of bomb disposal experts, state protocol duties, taking care of the burial places of soldiers and the support of national public employment have been specified.

Act CXXVIII of 2011 on disaster management and the amendment of certain related acts also deals with this issue.⁶⁰

“Protection and elimination of the consequences should be ensured by coordinating the operation of the bodies created for this purpose and the different protection systems, and by the involvement and collaboration, respectively, of citizens as well as civil defence organisations, business entities, the Hungarian Defence Forces, law enforcement bodies, the National Tax and Customs Administration, national meteorological service, national ambulance service, water administration bodies, the healthcare administrative agency, voluntarily participating social organisations as well as societies and public bodies created for this purpose; additionally the entity at fault and causing non-natural disasters, the national organisations and municipalities (hereinafter jointly referred to as participants of disaster management).”

Besides dealing with the changes of the security environment the *National Security Strategy* also lays down the duties of the Defence Forces:

“Global climate and environmental changes, the effects of the more and more extreme weather, the exhaustion of raw

- 4 Act CXIII of 2011 on National Defence, the Hungarian Defence Forces, and Special Measures Applicable for Special Legal Orders.
- 5 Act CXXVIII of 2011 on disaster management and the amendment of certain related acts.

difficulties of provision of food, emerging in a more and more serious form around the world involve considerable security risks and may become sources of conflicts. Environmental and medical hazards and the threats of civilisation that emerge globally, in the region or in Hungary do not only endanger the security and development of the country but also the region. In addition, because of its geographical conditions the damages of the environment and civilisation, floods, water and air pollution generated in adjacent countries in the Carpathian Basin have an increased effect on Hungary. Environmental threats have a direct affect on the health status of the population.

Natural and industrial disasters. If processes in certain industrial, biological, chemical and in particular nuclear facilities get out of control they may endanger or damage human health, environment and the safety of life and property on a large scale. A further risk is the transportation of hazardous goods by road, rail, and air or through pipelines.

The Hungarian Defence Forces must possess abilities through which it can actively contribute to the elimination of the consequences of natural or industrial disasters.”⁶

The *National Military Strategy* exists currently in a draft version. It breaks down the above mentioned duties to sectoral level.⁷ The planned Strategy is an important document of the renewal of the Hungarian Defence Forces that takes into account the guidelines laid down in the National Security Strategy as a sectoral strategy. In harmony with the Constitution of the country, with the legal regulations determining the activities of the defence area, the Strategic Concept of the North Atlantic Treaty Organisation as well as with the European Security Strategy it designates the strategic level goals of the period ahead of us and serves as a compass for the task of renewing the Hungarian Defence Forces.

The document lays down that the issue of national defence cannot be interpreted and managed by separating it from other areas of security. The importance of non-military aspects of security is growing, though at the same time this does not entail the decrease of the role of the military segment. The management of security challenges extends beyond the competence of specialised ministries and requires coordinated governmental cooperation.

Among the processes working against stability - in line with the documents set forth previously – the fight against terrorism, cyber threats, energy security, climate change and the resulting disaster situations that grow in number and severity receive special attention.

The duties of the Hungarian Defence Forces are expressed accordingly. The Hungarian Defence Forces is typically deployed in crisis management operations, in many cases far away from Hungary, under extreme natural and climatic conditions, on hard to reach terrain. During crisis management the network centric warfare, precision weapons and modern technology, civil-military co-operation, psychological warfare as well as the wide ranging deployment of Special Forces should be used. Crisis management usually takes place in weak countries which are unable to fulfil their basic duties, where security should be created and maintained against irregular, paramilitary organisations, rebels, armed groups, and international mercenary and terrorist groups.

Humanitarian intervention and assistance is more and more frequently required and, respectively, the deployment of military forces in humanitarian emergency situations as a primary means of intervention is more and more frequently needed. Crisis situations cannot be handled exclusively by military force; their management requires complex civilian and military efforts and co-operation, with special respect to the interdependence of military and civilian professionals operating in the same operational field. Military and civilian efforts cannot be sharply separated from

⁶ Government Decree No. 1035/2012. (II.21.) on the National Security Strategy of Hungary, Magyar Közlöny 2012 issue 19.

⁷ National Military Strategy (draft).

each other. Not only governmental players are present in the operational area but also numerous non-governmental players.

Within the frames provided by legal regulations the Ministry of Defence and the Hungarian Defence Forces create their internal controls and the order of deployment of available forces and assets.

Experiences from practice

We believe it is important to emphasise that participation in disaster protection is a high priority duty of the Hungarian Defence Forces. It is an obligation and opportunity to prove its preparedness and usefulness. The participation of the Hungarian Defence Forces in eliminating the consequences of disaster situations (mainly floods in Hungary) that are growing in number as a result of climate change is a determining factor. I mention this because there are endeavours to belittle this role and to underrate the role of military forces.

Facts resulting from the data of the last few years show the importance of the military role in flood control.

Period	Number of military forces participating (persons)	Number of officially appointed technical devices (pcs)
7 April – 12 May, 2000	4 260	553
5 March – 28 March, 2001	2 399	150
13 August – 24 August, 2002	3 025	175
31 March – 10 May, 2006	10 695	643
17 May – 23 May, 2010	455	55
July – 11 July, 2010	3 071	390

Table 1. Military role in flood control in Hungary

(Source: *Abilities of the Hungarian Defence Forces and the challenges of disaster relief 2000-2011, Zrínyi Media 2012*)

Flood control is not the only task for our soldiers. The forces and assets of the Hungarian Defence Forces were required to eliminate the consequences of the *red sludge disaster* that occurred in 2010. Abilities such as swiftness and uniqueness came to the fore, above all else. The army assisted rescue and restoration with 2 200 soldiers and 400 technical assets. The main duties were:

- continuous survey and transport of injured persons by helicopter;
- maintenance of airspace closure in the damage zone;
- hospitalisation of injured persons;
- radiological and chemical reconnaissance, analysis;
- ground or air decontamination of contaminated persons and assets (635 persons, 31 749 assets, 98 km roads);
- rubble clearance;
- providing the conditions for evacuation (4 000 field beds, 8 000 set of bedclothes);
- bridge construction;
- fuel transportation, provision of reefer containers.⁸

8 TOKOVICZ et al. (2012)

There was a bush fire in the Bugac region in 2012. The helicopters and vehicles of the army joined the fire-fighting. The Bambi Bucket, implemented in 1994 and used for aerial fire-fighting, carrying more than 1000 litres of water, was used during fire-fighting.

We have to mention here the organisational development that resulted in the establishment of the Tisza Multinational Engineer Battalion in 2002, after a long preparation period. The purpose of establishing the unit was to have an efficient, properly prepared military organisation with outstanding assets that can be deployed quickly against flood waves passing through the River Tisza; an organisation that is able and ready to help in any country concerned. Hungary, Romania, Slovakia and Ukraine provided a technical squadron each which are ready to perform their duties when needed. Thus the unit is a virtual organisation but a considerable resource and has joint exercises annually.

Principles of application

What are the advantages that favour the application of military forces?

- Military forces possess a complete logistics background, therefore when making use of it the mission leaders need not separately provide for supply, rest, topping up technical assets, their incidental transportation and medical support. An entire rescue force arrives with a complete set of assets. This is especially important when the other forces arriving to the location often cannot provide for their own supply. We have experienced, on several occasions during the 2010 flood protection that the forces and assets arranged for protection shortly became unfit for fulfilling the mission. Their rest, supply and logistics support was not organised.⁹
- Military forces have their own management-control system and the set of assets is compatible with the assets of other forces.
- Military forces possess special assets that other organisations do not have. Heavy-duty all-terrain vehicles, amphibious, aircraft, mobile lighting, heavy-duty water purifying equipment, logistics assets (tents, cooking station etc.).
- Military forces possess expertise that is not available – or only to a limited extent – to other organisations. explosive, bridge construction (floating as well as stationary), aerial transport and rescue, medical capacity (burn specialists), diver jobs, all forms of reconnaissance are a few samples taken at random of these expertise.

The principles of deploying military forces are similar here at home and abroad although the emphasis may be on different issues. The experience gained in recent decades provide application principles that can be put to good use both in flood control and in other disaster situations.

- Deployment should have more advantages than disadvantages.
- The duration, extent and scope of deployment should be proportional to the requirement.
- The required minimum criteria and circumstances suiting the situation should be provided.
- The utilisation of the forces and assets should be economical, and build up reserves.

Summary

There are certain areas in the life of the transforming Hungarian Defence Forces that are not affected by any change. One of them is the defence of the mother country; another is the missions fulfilled domestically, such as participation in protection against disasters. The changing security

9 SZABÓ-TÓTH (2010)

environment creates new areas of emphasis and our country is making efforts to react rapidly. The fact that the defence budget has never been so low does not make the life of decision makers easier either. Under these circumstances it is difficult but not impossible to preserve the abilities that ensure continued efficient participation in the protection against disasters. To achieve this it is also required that all entities concerned put emphasis on prevention because there is not any more economical and safer solution than a disaster prevented.

References

- SZABÓ Sándor – TÓTH Rudolf (2010): A 2010. tavaszi borsod megyei árvízi védekezés logisztikai támogatásának hiányosságai, okai, javaslatok azok jövőbeni kiküszöbölésére. In: *Műszaki Katonai Közlöny*. Vol. XX. No. 1–4. p. 21–37. (Deficiencies and reasons of the logistics support of the flood protection in Borsod County in the spring of 2010, proposal to eliminate them in the future. In: *Technical Military Bulletin*)
- TOKOVICZ József et al. (2012): A Magyar Honvédség képességei és a katasztrófaelhárítás kihívásai, 2000–2011. Zrínyi Média, Budapest. (Abilities of the Hungarian Defence Forces and the challenges of disaster relief 2000–2011.)

The Practice of International Search and Rescue in Haiti

SÁFÁr Brigitta – MuHOrAy Árpád¹

A powerful earthquake rocked Haiti on 12th January in 2010. The earthquake, according to experts - was stronger than had been observed for 200 years in the region. The world reacted immediately to the disaster. Global humanitarian assistance launched, in order to help Haiti's population. In the first phase of the assistance rescuers had to find survivors trapped under the rubble and had to save them from there. These tasks were handled by USAR teams arriving to the area according to UN INSARAG policies. The authors examine the possibilities of the practical application of INSARAG in Haiti. This study presents the advantages and disadvantages experienced during search and rescue work and explores the possibilities of further developments.

Introduction

According to the data of U.S. Geological Survey (USGS) the earthquake occurred on 12th January, on the mainland, 25 kilometres near to Port-Au-Prince in a west-southwest direction, in a 10 km nest depth, at 16:35 (local time), along the Enriquillo-Plantain Garden Fault. The intense, 7 magnitude quake according to the richter scale, caused huge disaster in and around the capital city. In the following one and a half months (between 12th January and 23d February) USGS registered 59 after-shocks stronger than 4.5, of which 16 were larger than 5.0. One of the two biggest after-shocks was a 6.0 magnitude, and occurred 7 minutes later than the earthquake. The other, 5.9 magnitude quakes happened on the 20th January. According to the official data 97 294 buildings collapsed and 188,383 were damaged, 222,570 people died, 300,572 were injured and 2,3 million became homeless. According to the estimations the losses reached 8 billion dollars.

Examining the international response given to a natural disaster we cannot ignore an analysis of the country's internal and external relations. In case of international operations it does matter whether the given country is able to take minimal measures in order to protect the population, search for and save survivors. In the case of Haiti it is particularly true. Studying the circumstances of the country we can see a rather sad picture in view of the administrative, political conditions which derive from the history of Haiti.

Historical and political background of Haiti

In the history of Haiti centuries old internal conflicts have resulted in an undeveloped country in every respect. Native Indians were exterminated by Spanish colonizers in the 25 years after the debarkation of Columbus. The French appeared in the beginning of the 17th century and acquired the west third of the island of 'Hispaniola' (Haiti) from the Spanish in 1697. The richness of the French colony was based foremost on forestry and the sugar industry. At the end of the 18th century Haiti's almost half million slave population started a rebellion which resulted in the first black republic in the world, founded in 1804.

¹ Email: brigitta.safar@voroskereszt.hu

Most of the history of Haiti was characterized by political violence whereupon it is the poorest state in the western hemisphere. Due to the crisis of the presidential election in 2000 preceded by the three decades of military dictatorship Haiti has still not managed to overcome the difficulties.²

There were 32 putsches in the last decade until 2008. Therefore the leaders holding authority paid almost no attention to the development of the country, they sought after power instead. The economy of the country currently depends on international support. „René Prével, *democratically elected president of Haiti (2004) confessed himself that he has very little true power, as the country is controlled by the World Bank Group and the International Monetary Fund.*”³ Haiti covered more than half of the government’s expenses from these sources in 2000. In this kind of environment the administrative reforms, and putting the country on the orbit of development is almost impossible. From the aspect of disaster management there can be no wonder if the country’s own administrative and non-existing defensive systems are not able to prepare for and react to the natural disasters.

The sanitary emergencies and natural disasters can cause bigger destruction under these circumstances.⁴ In a young democracy like this an administration, which does not work well or does not work at all, has as a result that most of the population is defenceless against natural disasters.

The official army of the country was demobilized after the democratic elections, only a few coast-guards and a smaller police force remained as an armed body. The uN’s peacekeepers have been working for the country’s stability and safety recently within the scope of MINuSTAH (United Nations Stabilization Mission of Haiti). Along with the uN’s forces the International Committee of red Cross (ICrC), as a representative of humanitarian rights, tries to support the population with smaller missions.

Earthquake in Haiti

Haiti’s difficulties do not end with the political-economic problems. Haiti lies on the border of the Caribbean plate and is located along the Central-American hurricane zone. As a result natural disasters such as tropical storms, hurricanes, earthquakes and floods are regular.

According to the EM-DAT’s (The International Disaster Database) charts more than 228 thousand people died due to natural disasters in the past decade, and these disasters affected more than 4 million people. To sum up we can say that from the aspect of disaster management Haiti is not able to perform independently in connection with preparedness, reaction, and restoration.

The earthquake, that occurred in 2010, caused far more damage in this country than ever. The world immediately reacted. In the first few days and weeks a remarkable number of organizations arrived with enormous human resources and logistics in order to help the rescue and aid of the population. After the assessment, necessary for applying international forces, the most important things to do, as always in cases of disaster, were connected to rescuing and saving human lives. These are, for instance, searching for survivors, taking care of injured ones, setting up field-hospitals and checkpoints with basic medical help; creating and coordinating temporary accommodations and camps; supplying populations with food, clean water, and essential tools for everyday life. At the same time it is very important to inform the population and public opinion and to protect the public order.⁵

2 KOVÁCS–SZIGETI (2006) p. 212.

3 KérI

4 WHO: Haiti health profile. <http://www.who.int/gho/countries/hti.pdf> (06.10.2012.)

5 IFCrC. http://www.ifrc.org/Global/Publications/disasters/208400First%20anniversary%20Haiti%20EQ%20operation%20report_16b.pdf (28.04.2011.)

The INSARAG guidelines

The head of the international aid operation was the UN's different professional organizations, which were responsible for supervising the special fields. The search, rescue and mobilization, for instance, were coordinated by OCHA and UNDAC.

In the course of interventions and the accomplishment of tasks the INSARAG principles were normative. In order to understand the tasks in general in connection with Haiti it is necessary to review the responsive organizations according to the principles to which, as I will unfold later, new experience was added by the earthquake of 12th January.

UN's Office for the Coordination of Humanitarian Affairs (OCHA) is the secretariat of ISARAG's ruling committee. Its function is to control and coordinate international support in case of disaster or humanitarian crisis. These activities consist of coordinating other organizations along with their own units and teams, as well.

Throughout the execution of tasks, OCHA collaborates closely with the given country's Local Emergency Management Agency (LEMA) which is the lowest controlling body and supervises the immediate actions. LEMA cooperates with United Nations Disaster Assessment and Coordination (UNDAC). The first function of the group is supporting the local forces in reacting to the disaster. It also helps to coordinate (including USAR teams), to purchase necessary equipment, and it controls the setup of OSOCC.

On the strength of coordinating and controlling groups' work International USAR teams do the search and rescue tasks. The teams work alone or collaborate with other teams. In the case of a given international intervention the USAR teams will arrive at the rDC if that is set up. rDC is a kind of entrance, the point of the damage zone where newcomers can get informational support about the state of local emergency management.

On-Site Operations Coordination Centre (OSOCC) is the platform of cooperation between international forces and LEMA. Its setup is the responsibility of UNDAC or the first USAR team that arrives at the scene. Its main purpose is to help LEMA in humanitarian questions and coordinating international and national forces. If the damage zone requires it one main and other minor OSOCC centres can be erected. There is a web-based informational platform connected to OSOCC (Virtual OSOCC) its first aim is to ensure fast communication between the damaged country and the supportive agencies. The main purpose of INSARAG's teams is the assurance of efficient and effective intervention on both national and international levels. In order to do that, however, certain stages of intervention and the duties they contain are very important factors.

Preparation Stage – involves the time period between disasters when the formerly acquired experiences are elaborated and evaluated; essential modifications and corrections are made towards SOP; training sessions are put in progress and future operations are planned.

Mobilization Stage – consists of events after the natural or civilization disaster and includes alarming, mobilizing and sending the international USAR teams to the damaged countries.

Operational Stage – any operations which contain the arrival of international USAR teams to the rC and its registration; meeting of team leaders and orientations in OSOCC; reports to the disaster management agency of the sending country; USAR operations in the damage zone until the Operational Stage finishes.

Demobilization (withdrawal) Stage – includes the time period when USAR teams stop their activities in the damage zone, hand in the reports to international and national authorities, and start preparing to go home. The withdrawal of the teams is coordinated by the OSOCC from the damaged country to rDC.

Post-operational Stage – time period after uSAR operations are closed; when uSAR teams arrive home, reports and financial reports need to be written about the mission. These summaries should consist of an empirical overview which can develop the efficiency of the cooperation in the future.⁶

Preparing for each stage can bring a successful intervention. In case of Haiti the first USAR team arrived at the scene in less than 24 hours which can be considered really fast. Based on the foregoing I will review the circumstances of international responses to the earthquake of 12th January 2010 from the aspect of INSARAG principles.

Search and rescue operations in Haiti – INSARAG into practice

The first signal of the natural disaster arrived at 23:05 (GMT+1, according to Geneva’s time) to OCHA. Soon after that UN’s INSARAG mobilization order was activated. The possible member list of UNDAC team, which arrived at Port-au-Prince on 13th January, was ready at 23:40. The primary task was to estimate the needs and to make the plan of action, which provided support and control for the local humanitarian coordinator. Cooperating with local organizations and following the INSARAG principles the structure, shown by the illustration evolved.

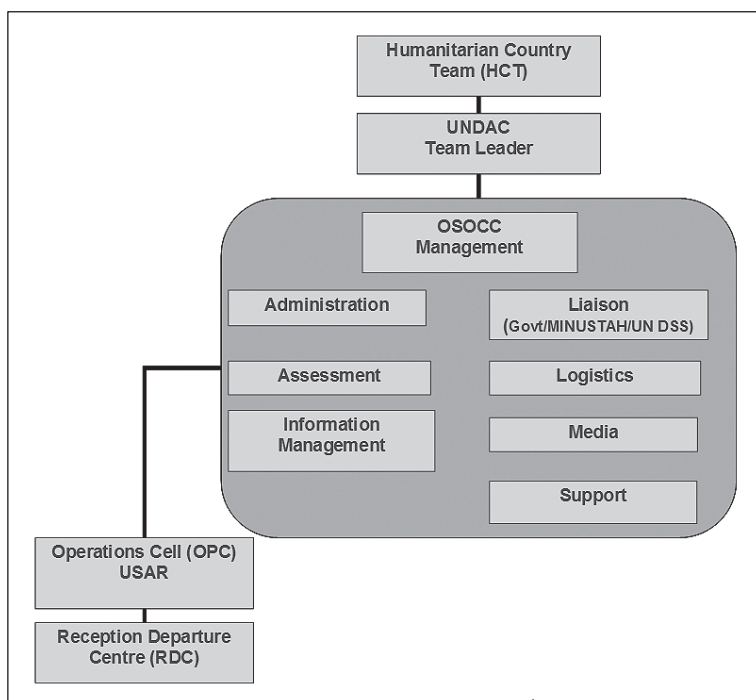

Figure 1. The structure of international intervention in Haiti

(Source: UNDAC MISSION REPORT Haiti Earthquake, January 2010; page 6.)

6 OCHA: INSARAG Guidelines. http://www.insarag.org/images/stories/INSARAG_Guidelines_and_Methodology_2011_edition_Hungarian_translation.pdf

In order to welcome the international forces rDC (later OPC) was established on the seriously damaged Port-au-Prince airport. As a result of the area's conditions it was perfectly capable of creating a base for uSAR teams because the airport was suitably surrounded by walls and was protected by military. Due to the limited capacity the airport and the numerous teams arriving, another base at Santo Domingo was established by rCD. OSOCC was instituted at united Nations Stabilization Mission in Haiti (MINuSTAH) which is about 2 kilometres away from the airport so the distance did not cause any problem.⁷

First reports on the earthquake contained the information that several high buildings including hospitals, schools, hotels and blocks of flats collapsed. These buildings were at the top of the RCD priority list with reference to search and rescue tasks. First the uSAR teams started working at these buildings.

42 blocks were formed in the region of Port-au-Prince which covered 63 square kilometres. Teams, qualified as advanced ones by INSARAG, were directed to the most affected areas. Then, as teams continuously arrived and there were enough advanced, medium and easy teams available, teams were ordered to fields according to each sector's priority listing. Theory was based on assessing each sector in order to define priorities. each team got to their area at 6 o'clock in the morning and was asked to keep in touch with OPC all day. Then every evening at 19:00 team leaders discussed the events of the day, gave in their reports, and their analysis led to the tasks of next day.⁸

According to the air reconnaissance it was brought to light in the first week that suburban areas need uSAR teams as well despite the fact that there were no high buildings. uNDAC groups needed to handle urgent humanitarian emergencies along with search and rescue tasks in these areas since most of the survivors here spent everyday in the open air. Search and rescue tasks were helped by alternative information channels. Survivors trapped under the ruins gave signs of life via messages or phone calls by which the teams could start rescuing them after a cross-check. In this respect there is an interesting fact. Some teams wanted to communicate with OPC through satellite phones but since every representative of the media used this technical bandwidth it was saturated and teams could not report to OPC. This caused a problem in public security because the teams could not report the threats either.

Besides the security threats, providing devices and fuel for conveying the teams involved difficulties, as well. Local government could not provide resources properly so UN's MINUSTAH forces accomplished the logistic duties.

Summary

Despite the difficulties 50 USAR teams from 30 nations with 1800 people and 160 dogs took part officially (between 14th – 22th January) in the operations in the search and rescue stage.

As a result it can be set up that the following lessons can be learnt from the Haiti-intervention with regard to the further development of the search and rescue methodology:

- virtual OSOCC is an excellent platform for fast information flow. Although development and applying information technology equipment should not be disregarded. For real-time voice-transmitting Skype is excellent, which for example, allows people from different places of the world to make conference calls.

7 uNDAC MISSION rEPOrT Haiti Earthquake, January 2010

8 Ibid.

- as long as the disaster occurs in a high security risk area it is expedient to include a person from the uNDAC group from the uN's DSS team.
- in case of such huge disasters, contacting and staying in contact with local authorities is pivot- al. Sharing information with the humanitarian community is also crucial.
- with respect to the INSARAG methodology this disaster was instructive, among other things it taught us if an INSARAG methodology can be established in other humanitarian fields or not.
- in case of every disaster which affects large populations NGOs also arrive at the area with whom coordination is needed to be supervised as well in order to avoid initial chaos.

References

- IFRC. http://www.ifrc.org/Global/Publications/disasters/208400First%20anniversary%20Haiti%20EQ%20operation%20report_16b.pdf (28.04.2011.)
- KÉRI András, dr.: *Haiti és a fehér ember történelme*. http://web.kvif.bgf.hu/upload/menu_content/doc/20100920150535X_NyV9_KeriA2.pdf (28.04.2011.)
- KOVÁCS Péter – SZIGETI Borbála (2006): *Földrajzi Világtalasz*. Cartographia Kft, Budapest. OCHA: INSARAG Guidelines. http://www.insarag.org/images/stories/INSARAG_Guidelines_and_Methodology_2011_edition_Hungarian_translation.pdf uNDAC
- MISSION rEPOrT Haiti Earthquake, January 2010
- WHO: Haiti health profile. <http://www.who.int/gho/countries/hti.pdf> (06.10.2012.)

Assessment of the Implementation Practice of Emergency Planning Regulations Dedicated to the Rail Transportation of Dangerous Goods

KÁTAI-URBÁN Lajos – HORVÁTH Hermina¹

These days it is especially important, and a complex task at the same time, to protect human health and the environment at a high level. One of the most important elements of this protection policy is industrial safety, highlighted by the major accidents of recent years. Industrial safety embraces four special fields: the supervision of dangerous plants, the control of the transportation of dangerous goods, the protection of critical infrastructure and the prevention of nuclear accidents. In our essay we dedicate our attention firstly to the assessment of the international and national legal regulations concerning the emergency planning of the railway's dangerous activities. Secondly, the main goal of this article is to analyse the implementation of the above mentioned regulations by the operators of Hungarian railway infrastructure.

Introduction

The special safety requirements of the transportation of dangerous goods are stipulated in legal regulations in Hungary, and we are bound to follow them by strict international rules. In terms of the transportation of dangerous goods by road, rail, inland waterways and air transportation, they all have their respective regulations.

In spite of the strict international and national regulations there were numerous accidents in Hungary and abroad as well, highlighting that in addition to prevention we have to be prepared in all cases to be able to manage and control the occurring event in a professional way, and we have to make our best efforts to reduce potential consequences and their effects to a minimum. In order to implement this in practice we have to apply a comprehensive emergency management plan. In consideration of the functioning of our country as a EU member state, we have to streamline continuously the Hungarian norms, technical and methodological requirements corresponding to the expectations of the European regulations related to the prevention of emergencies, and within this that of major accidents involving dangerous substances.

The vulnerability assessment and emergency management planning activities applied in case of establishments using dangerous substances shall be carried out in case of marshalling yards as well. During the transportation, storage of dangerous substances and for the sake of the safety of installations we have to consider the appearance of the aforementioned risks and we have to fulfil in any and all cases the requirements stipulated in the directive 96/82/EC, on the control of major accident hazards involving dangerous substances (hereinafter: Seveso II. directive).

In line with the description above, in our essay we will analyse the aspects of industrial safety in cases of rail transportation. In order to obtain an overall picture of the topic it is necessary to review

¹ Both authors: Institute of Disaster Management, of the National university of Public Service, Budapest, Hungary

the basis of international and national legal regulations related to dangerous goods transported by rail, the system of national emergency management planning and the company regulations of the Hungarian State railways Plc. (Magyar Államvasutak Zrt.) (hereinafter: MÁV Zrt.) as the operator of the rail tracks system in Hungary, as related to the emergency management planning of marshalling yards used for dangerous goods.

Evaluation of major accidents that happened in Hungary and world-wide in the presence of dangerous goods

In the world there were numerous industrial accidents with major consequences that went beyond the site borders and endangered neighbouring settlements as well. One of them was the environment pollution caused by dioxin 1976 in Seveso, Italy, another the massive poisoning caused by methyl-isocyanine released at the site of union Carbide in Bhopal, India in 1984 (see Table 1.).²

year	Location	Consequences
1976	Seveso, Italy	July 1976 in North-Italy, in the course of an accident at a chemical plant of Hoffman La Roche in Givaudan (close to the small town, Seveso next to Milan) producing pesticides, dioxin was released into the atmosphere. The poisoning caused by the dioxin cloud resulted in the emergency slaughter of some 100,000 cattle. The accident did not take a toll on human lives, but several hundreds of people had to be evacuated.
1984	Bhopal, India	From the underground tank of the plant of union Carbide in Bhopal producing pesticides and polyurethane a highly toxic gas (methyl-isocyanine) was released. Within a short time some 400,000 people suffered harm, and poisoning in different degrees. There were 3,135 fatalities.
1984	Mexico City, Mexico	On November 19, 1984 in Mexico City one of the gas tanks of the state-owned oil company exploded. A high quantity of liquid gas was spilled, causing fire, explosion and then several BLEVE-s. 400 people lost their lives in the accident, more than 1,000 people were seriously injured, 300,000 inhabitants had to be evacuated from the surroundings of the establishment.

*Table 1. Data of major industrial accidents 1.*³

Some of the major accidents affected not only the local community, but spread beyond the state boundaries into neighbouring countries, and potentially the states located on the downstream catchment area. It is enough to think of the event that happened in 1986 in the Sandoz factory in Switzerland or of the cyanide and heavy metal pollution in Nagybánya (Baia Mare) February 2000, which caused environmental damage in several countries in the Rhine, Tisza and Danube rivers (see Table 2.).

Numerous international and national examples can be used to demonstrate events of the rail transportation of hazardous goods. In the following table the transportation data of some accidents related to the rail transportation of hazardous goods by rail that happened recently and aroused the attention of the media are listed (see Table 3.).

2 KÁTAI-URBÁN (2006)

3 Source: KÁTAI-URBÁN (2006)

year	Location	Consequences
1986	Basel, Switzerland	Because of fire in the storage room of insecticides a high quantity of firewater made its way into the sewer and then into the Rhine and due to this during the next days most of the fauna of the river was destroyed. An environmental disaster polluted a 500 km long transboundary section of the Rhine.
2000	Nagybánya (Baia Mare), Romania	The cyanide storage lake of the Aurul mining company is in the vicinity of Nagybánya (Baia Mare), which was exposed to such a high water load that the badly designed dam burst along a width of 25 m on January 30, 2000. At least 100,000 m ³ of highly toxic wastewater, containing at least 120 tons of cyanide (lethal doses for 2 million people) was spilled. The toxic wave polluted the whole Hungarian section of the Tisza river, and did not spare Voivodina and the Danube and the Black Sea either.
2000	Borsabánya, Romania	On March 10, 2000 in the morning hours there was a dam slide at the Novac settlement storage basin owned by the Romanian company Romin in Borsabánya because of the heavy rain. 10-20 thousand m ³ of pollution (containing lead, zinc and copper) got via the river Visó into the Tisza river.
2005	Buncefield, United Kingdom	On December 11, 2005 in the morning an oil storage facility exploded in Buncefield located to the north of London. The explosion damaged buildings within a wide radius. Twenty tanks, with a storage capacity of 14,000 m ³ each, burned down. 43 were injured, there were no fatalities, at the same time 2,000 people had to be evacuated for the night.
2005	China	On November 13, 2005 there was an explosion in the catchment area of the Songhua river in Csilin province, on the territory of the chemical plant 380 km from Harbin (China), where some 1,000 tons of benzene made its way into the surface water and the concentration of nitrobenzene was 108 times higher than the allowed level. In the large city with four million inhabitants people panicked because of the 80 km pollutant spot getting closer and this impacted the relationship between Russia and China. In China water consumption, in Russia fishing was prohibited by the authorities. An attempt to neutralize the chemicals by means of active carbon took place.

Table 2. Data of major industrial accidents 2.⁴

year	Location	Consequences
2012	Mosonmagyaróvár-Bagolyvár	On March 24, 2012 in the marshalling yard of Mosonmagyaróvár sulphuric acid leaked from one of the wagons of a train consisting of 8 wagons. The accident did not endanger inhabited areas, but for the duration of the emergency management the area affected by the emergency was closed in a radius of 100 m. The cargo (57 tons) of the wagon was transloaded into the empty tank of the establishment at the destination, the dangerous substance that leaked into the area between the rail tracks was neutralized.
2012	Máriabesnyő, in the vicinity of Bag	On May 12, 2012 the last seven empty wagons of a freight train consisting of 42 containers derailed. There was sulphuric acid in one container but nobody was injured from the accident. The experts of the rail company and of the rescue organisations have restored the damage caused by the accident by May 14.
2012	In the vicinity of Cegléd	On December 11, 2012 a van transporting isotope capsules considered hazardous goods crashed with a train in the vicinity of Cegléd. The van transported 25 kg of hazardous goods, according to the papers of the vehicle, 192 pieces of isotope capsules were in a small container. The container was damaged in the accident, but there was no dangerous substance released into the atmosphere, as the capsules did not break.

Table 3. Data of railway accidents⁵

4 Source: VASS (2006)

5 Source: MI NDGDM

The events listed in the table aroused the attention of experts and the public because of their major consequences possibly directly threatening human health and life. However we can conclude from the experience of several near-misses (incidents) that every incident caused by technical defect of human error or external effect implies the possibility of the occurrence of major events and sometimes disasters. In our opinion, for the prevention of such events a high-level authority licensing, supervision and control system is required, in addition to the emergency management planning system ensuring the professional management of incidents that have already occurred.

International and national legal regulation of the prevention of major accidents in disaster management

The community-level integration of the prevention of industrial accidents looks back to a history of more than two decades, the Seveso directive undergoes some modifications and gets stricter and stricter every five years. In line with the European integration activity and the international obligations of the country the Hungarian Parliament and government has prepared regulations about the prevention of major industrial accidents. The effective date of the Hungarian regulations is January 1, 2002 and has been modified significantly twice (2006 and 2012).

Our country undertook as of January 1, 2002 to integrate the Seveso II. Directive into the legal regulations of Hungary and to implement the provisions specified in the same text before the date of the EU accession. The directive (2003) took effect in 2006 in Hungary with the objective of preventing major industrial accidents involving hazardous substances, mitigating its effects on man and environment, and ensuring a high-level of protection in a consequential and efficient way on the territory of the European Community.⁶ The UN ECE Convention on Industrial Accidents introduced simultaneously with the Seveso regulation handles the cross border effects and consequences of industrial accidents potentially occurring in an upper tier establishment using dangerous substances identified according to the Seveso II. Directive.

The Directive excludes marshalling yards mentioned in Article 4 from the scope of application, however the Council Directive No. 96/49/EC⁷ designates interim temporary storage at marshalling yards as “a station necessary in the course of transportation”.

One of the triggers of the changes in legal regulations between 2010-2011 serving the improvement and development of the disaster management system was the strengthening and establishment of more efficient protection against major accidents involving dangerous goods. Recent events, like the industrial catastrophe caused by the dam bursting of the mining waste reservoir in the outskirts of Ajka on October 4, 2010 or major accidents that happened in establishments processing hazardous wastes, in meat processing establishments, in establishments using chlorine and in establishments handling pyrotechnic products have contributed to the changes of the disaster management regulations concerning the legal field of industrial safety.

Act 2011 CXXVIII. on disaster management and on the amendment of individual, related acts (disaster management act) and the regulation 219/2011 (X. 20.) on the protection against major accidents involving dangerous substances (hereinafter: implementation regulation) - in line with the Seveso II. Directive - clearly define the scope of activities covered by the regulations, the tasks of the authorities related to the activities, the tasks of the operators of dangerous

6 VASS (2006)

7 KOSSA (2011)

establishments, of the government and municipalities related to the prevention of and preparation for major accidents, and to the emergency management of the same and also the obligations related to information made public.

There are new tasks and competences of industrial safety specified in the disaster management act and in the implementing regulations listed below:

1. Extension of the rights of the disaster management authorities (licensing, supervision, inspection) over establishments below the lower threshold level,
2. Introduction of new legal institutions (emergency management fine, administration service fee);
3. Disaster management tasks of the protection of critical infrastructure;
4. Making the authority activities and procedures more simple and efficient;
5. extension of the controlling and fining authorisations of the disaster management authority with regard to the transportation of dangerous goods by rail, air and inland waterways.⁸

These new tasks and competences and their efficient and successful implementation requires the extension of the previously operated structure of industrial safety and the establishment of an organisation for industrial safety and code of procedure.

The last modification of the Seveso II. Directive was necessary among others to adapt the Seveso regulation to the CLP regulation (regulation 1272/2008/EC of the European Parliament and Council on the classification, labelling and packaging of materials and blends). The directive 2012/18/EU of the European Parliament and Council (Seveso III directive) on the management of the hazards of major accidents involving dangerous substances and on the modification and later cancelation of directive 96/82/EC has been adopted on July 4, 2012. The Seveso III. Directive shall be introduced by the EU member states and thus also Hungary by the end of May 2015.

Emergency management planning system of plants

The paramount goal of emergency management planning in Hungary is to create a standardized system of documents by means of the identification and analysis of various endangering factors, containing disaster management tasks and actions with the allocated human resources, finances and technical means. The rules of the preparation of the plans, those obliged to prepare emergency plans, the content of the plans and the order of approval are described in the Government Decree 234/2011 (XI. 10.) on disaster management and on the execution of act CXXVIII. of 2011 on the amendment of related individual acts (Act on Disaster Management).

Emergency management planning helps in every case minimize consequences, where an accident causing serious damage to the environment or to the public can occur. It integrates the order, implementation of disaster management tasks and actions into a standard system, by allocating the necessary human resources, funds and technical means.

The levels of emergency management planning are:

- a) Settlement emergency plan,
- b) Workplace emergency plan,
- c) The summarized plan of the local organisation of the official emergency management organisation,
- d) regional (county or capital) emergency management plan,
- e) Central (national level) emergency management plan.

⁸ KOSSA (2011)

Included in the plans are first the conditions of emergency management in the course of the dangerous situation, the actions to be taken within a short time after the accident and the key decisions that can significantly influence the success of the mitigating actions.⁹ On this basis it is clear that the deep understanding of the probable scenario of the events and of the counter-measures is very useful for those who can play a role in the emergency response and damage control.

In the sense of the IV-th chapter of the Disaster Management Act. the operator of the establishment dealing with dangerous substances prepares an internal emergency plan in order to eliminate the consequences of the dangers described in the safety report (upper tier site) or in the safety analysis (lower tier site).

The provisions of the safety analysis and safety report regarding the prevention and control of major accidents related to dangerous substances shall be elaborated in such a way as to ensure the high-level protection of human health and the environment. To this end it also has to cover the concept regarding the resources and tools, organisation and management system required for an efficient emergency management system.

The safety documentation that includes the internal emergency plan as well, is revised and if necessary modified by the operator in case of an establishment dealing with dangerous substances in the cases stipulated in the execution regulations (government decrees), at least every five years. The operator sends the results of the revision and the modified safety analysis or report to the disaster management authority. The authority decides on the basis of the safety report or analysis received about the extension of the permit or about requiring prevention or consequence mitigation measures.¹⁰

The aforementioned actions serving the high-level protection of the public do not appear directly in the legal regulation guaranteeing the safety of rail transport.

Infrastructure and safety regulation of the rail transport of hazardous goods in Hungary

The European Council and Parliament has adopted the so called TEN plans of transportation in 1996, with the objective of establishing a standardized road, rail, sea and air transportation infrastructure within the territory of the EU. One of the cornerstones of the railway policy of the EU is that during the years to come a high volume of dangerous goods, if possible, shall be shifted to railway. Within the rail transport of goods the ratio of the transportation of dangerous goods is between 19-20%. Compared to road transportation a major advantage is the more economic transportation over a long distance, while weather conditions and traffic risks are less relevant than on the road. The evaluation of the hazardous goods transported in Hungary, based on the goods' classes, shows that railway transportation is focussed mainly on the transportation of inflammable materials, gases and corrosive materials. The ratio of toxic materials and explosives is lower, compared to the aforementioned materials.¹¹

9 VArGA 2005

10 2011. évi CXXVIII. törvény a katasztrófavédelemről és a hozzá kapcsolódó egyes törvények módosításáról (Act 2011/CXXVIII. on disaster management and related individual acts.)

11 Veszélyes áruk vasúti forgalmának megoszlása áruosztályok szerint. In NAGY Zsolt ed.: *Veszélyes áru Évkönyv 2011 Magyarország*. Biztonsági Tanácsadók Nemzetközi Szakmai Egyesülete. Budapest, 2012, p. 69. (Split of dangerous goods in rail transport by goods classes. In: International Professional Association of Safety Consultants, yearbook of Dangerous goods 2011, Hungary.)

There is a difference of opinion among experts as to whether the rail or road transport of hazardous goods represents a higher degree of danger for those living in the area concerned. In terms of transport mode preferences there are no special transportation authority measures or provisions in the territory of the EU member states. In general it can be stated that it is mainly economic and logistic considerations that play a role in the selection of individual transportation modes. However it is sure that in cases of transportation of significant volumes over a long distance (more than 200 km) rail transportation services and facilities are preferred.

In the territory of marshalling yards as temporary storage installations, there are toxic, flammable and explosive materials, and in cases of major accidents involving these substances the effects harming human health can spread over several hundreds of meters or even kilometres.

Special safety conditions regarding the transportation of dangerous goods are specified in legal regulations in Hungary. We are bound by interstate agreements to follow these regulations in international transportation. International regulations are strict and in most cases also highly up-to-date. They reflect the international cooperation of experts from industry, environmental protection and safety, which is necessary because of the international nature of trade and transportation and because of the standard safety level desired. In terms of the transportation of dangerous goods there is an independent regulation for railway transportation, the “regulation concerning the International Carriage of Dangerous Goods by rail” (hereinafter: RID), which is annex “C” to the Convention concerning International Carriage by rail (COTIF) C, and which was concluded on June 3, 1999 in Vilnius.

The amendment of the Disaster Management Act that took effect on January 1, 2012 and of the related sector-specific act (Rail Transportation Act CLXXXIII of 2005.) created the legal background for the disaster management organisation to inspect the rail transportation of dangerous goods as an independent authority and can if needed impose fines and take other actions to avoid emergency situations.

By virtue of the authorization, based on the amended sector-specific acts, the Government Decree No. 312/2011. (XII. 23.) on the rules of the standard procedure regarding the inspection of the rail and inland waterways transportation of dangerous goods and on imposing fines and on the amount of fines that can be imposed in case of anomalies and on the general rules of authority tasks related to fining, has been issued in order to describe the implementation in detail.¹²

On the basis of the first result of the application of the regulation concerning the inspection of dangerous goods transported by rail, that took effect recently, it can be established that there were 747 so-called RID inspections performed by the disaster management authorities in 2012 and the disaster management experts have inspected a total number of 10,095 railway vehicles. Among these there were 5,176 railway vehicles transporting dangerous goods. The inspecting authorities found 194 railway containers to be defective or not in line with the regulations.¹³ It is evident, from the above mentioned control data, that with regard to industrial safety, inspections performed by the disaster management authorities and prevention and preparation measures (obligations) introduced by those of authority after the inspections in case of irregularities and omissions are absolutely needed.

12 BOGNÁR–VASS–KOZMA (2012)

13 *Veszélyes áruk vasúti szállításának ellenőrzése 2012.* MI NDGDM, Annual report 2012. (Inspection of the rail transportation of hazardous goods.)

Practice of internal emergency response planning at marshalling yards

In 2003, with the help of the European Commission the decision of the uIC International union of railways "Guideline for the preparation of internal emergency response plans at marshalling yards"¹⁴ were published. The guideline is considered, on the basis of the rID regulation, as a basic document in the area of emergency response planning.¹⁵

The provisions of rID shall be applied in national and international transportation as well. In the sense of the effective legal regulations in Hungary regarding the transportation of dangerous goods official disaster management organisations do not have licensing and supervising tasks and competences, which applies also to the internal emergency response plans to be prepared for marshalling yards according to the Chapter 1.11. of rID regulations.

MÁV Zrt. has prepared, according to its internal regulations based on the rID regulation, the internal emergency response plans of the four major marshalling yards (Záhony, Miskolc, Budapest-Ferencváros and Szolnok) handling dangerous goods. Later, in the order No. 33/2009. (V.1.) of the director-general this area was newly regulated, covering in detail the emergency management tasks of the company in case of accidents occurring in the course of the transportation of dangerous goods or in response to the impact of dangerous goods released during an extraordinary event, endangering man and environment. In line with the decision uIC 201 E, as of 2003, an internal emergency response plan shall be prepared for marshalling yards involved in the transportation of dangerous goods. Internal emergency response plans shall be revised every year and shall be updated as needed. In case of new marshalling yards the emergency response plans shall be prepared before the start of the function, allowing the simultaneous modification of the external emergency response plan prepared by the local authorities.¹⁶

In case of marshalling yards already in operation, following the changes of the internal emergency response plan the external emergency response plan shall be revised and modified if needed. These documents shall always be up-to-date, usable at any time and have to contain all the information the response team might need.

The emergency response plans of the marshalling yard falls within the competence of the marshalling yard operator. In order to prepare the internal emergency management plan and to have it tested, railway companies shall cooperate with the operator of the railway infrastructure. The plan covers the complete response of the operator in connection with the accident occurring with a dangerous substance at the marshalling yard, and shall describe in detail, how the operator shall prepare the persons working in the area affected by the emergency, and how to control, limit and mitigate the effects of any emergency. The plan describes as well, how external organisations sent to the location of emergency and those working at the site could help, how the work of external organisations is helped, while ensuring the safety of the persons affected. In order to implement the contents of the emergency management plan the persons in charge shall be identified by their respective names, positions and all those responsible persons shall be identified, who supervise

-
- 14 UIC Nemzetközi Vasútegylet „Útmutató a belső veszélyelhárítási tervek készítésére a rendezőpályaudvarokon” c. döntvénye, 2003. (International railway Association, decision “Guideline for the preparation of internal emergency plans at marshalling yards”)
 - 15 A veszélyes áruk nemzetközi vasúti szállításáról szóló előírás (RID), 2012. (Regulation concerning the International Carriage of Dangerous Goods by rail.)
 - 16 33/2009. (V. 1. MÁV ért. 15.) VIG order of the director-general about the tasks of MÁV Zrt. in disaster management and civil protection.

and coordinate emergency response and mitigation measures.¹⁷ The damage control, emergency management of an accident is the task of the maintenance company of MÁV Zrt. within the frame of its services.

The plans shall be based on the individual needs of the marshalling yards, on the danger situations that can be identified and on the management actions of such danger situations, and shall cover all major accident situations and scenarios that can be foreseen. The plan is based on the identified hazards of the accidents that have already occurred, where always the worst case scenario shall be considered.¹⁸

One of the most important units to be set up when an accident occurs and to be considered when preparing the emergency management plan is the emergency management centre. Emergency response operations are steered and coordinated from here. The centre liaises with the response team, the local authorities, hospitals, local health authorities, with the management of the rail company and with the media.

After the transformation of the organisational structure of MÁV Zrt. the tasks of rail track system operation, railway safety, transportation, accident response and control are split among MÁV Zrt. as rail track system operator and the railway companies. As part of the cooperation between the Ministry of the Interior, the National Directorate-General for Disaster Management and MÁV Zrt., within a common (pilot) project in 2011 an internal emergency management model plan has been prepared for the marshalling yards in the region of Záhony near the Ukrainian border, which can be the basis for the preparation of the plans of other marshalling yards.¹⁹

Conclusion

All in all it can be stated that in terms of marshalling yards the disaster management authority, for lack of authorization by relevant Hungarian legal regulations, at the present on the basis of a cooperation agreement with the MÁV group, can offer, instead of authority supervision, professional assistance to the operator of the rail tracks for the sake of the improvement of the emergency management activities.

However within the excellent professional cooperation between the disaster management and railway system operators the international and national methodological guides required for the preparation of the emergency response plans and the results of the common pilot project (sample plans) are available.

All these actions create suitable conditions for the preparation of the internal emergency plans of establishments in case of all marshalling yards and afterwards the elaboration of the external emergency plans of settlements, and after the provision of the conditions of their application for ensuring the high-level safety of the public.

17 219/2012. (X. 20.) regulation about the protection against major accidents involving dangerous goods

18 SZAKÁL et al. (2012)

19 *Veszélyes áruk fuvarozása – Módszertani útmutató a rendező pályaudvarok veszélyelhárítási tervezési feladatainak végrehajtásához.* BM OKF, 2004. (Transportation of hazardous goods – Methodological guideline for the implementation of the emergency management planning at marshalling yards.)

References

- A veszélyes áruk nemzetközi vasúti szállításáról szóló előírás (RID), 2012. (Regulation concerning the International Carriage of Dangerous Goods by rail.)
- BOGNÁR Balázs – VASS Gyula – KOZMA Sándor (2012): A BM OKF Országos Iparbiztonsági Főfelügyelőség szakterületeinek bemutatása. In: *Új Magyar Közigazgatás*. 2012/6. p. 19-27. (Presentation of the special fields of the National Chief Inspectorate for Industrial Safety MI NDGDM)
- KÁTAI-URBÁN Lajos (2006): *Az ipari balesetek országhatáron túli hatásai elleni védekezés alkalmazási feltételeinek értékelése és fejlesztése*. Doktori (PhD) értekezés. Budapest. (Evaluation and development of the conditions of the application of the protection against the cross border effects of industrial accidents. Phd dissertation.)
- KOSSA György (2011): Iparbiztonság – feladatok és kihívások a jövő védelmében. In: *Védelem- Katasz- trófa- Tűz- És Polgári Védelmi Szemle*. 18. (6) pp. 49–50. (Industrial safety - tasks and challenges to protect the future)
- SZAKÁL Béla – CIMER Zsolt – KÁTAI-URBÁN Lajos – SÁRÓSI György – VASS Gyula (2012): *Iparbiztonság I. Veszélyes anyagok és súlyos baleseteik az iparban és a szállításban*. Korytrade Kft., Budapest. (Industrial safety I. Dangerous goods and major accidents in industry and transportation.)
- UIC Nemzetközi Vasútegyetlet „Útmutató a belső veszélyelhárítási tervek készítésére a rendezőpályaudvarokon” c. döntvénye, 2003. (International railway Association, decision “Guideline for the preparation of internal emergency plans at marshalling yards”)
- VARGA Imre (2005): *A veszélyes anyagokkal kapcsolatos súlyos balesetek elleni megelőzési és védekezési tevékenység rendszere*. Doktori (PhD) értekezés. Budapest. (System of prevention from and protection against major accidents involving dangerous goods. Phd dissertation.)
- VASS Gyula (2006): *A településrendezési tervezés helye és szerepe a veszélyes anyagokkal kapcsolatos súlyos ipari balesetek megelőzésében*. Doktori (PhD) értekezés. Budapest. (The place and role of the land use plan in the prevention of major industrial accidents involving dangerous goods. Phd dissertation.)
- Veszélyes áruk fuvarozása – Módszertani útmutató a rendező pályaudvarok veszélyelhárítási tervezési feladatainak végrehajtásához*. BM OKF, 2004. (Transportation of hazardous goods – Methodological guideline for the implementation of the emergency management planning at marshalling yards.)
- Veszélyes áruk vasúti forgalmának megoszlása áruosztályok szerint. In NAGY Zsolt ed.: *Veszélyes áru Évkönyv 2011 Magyarország*. Biztonsági Tanácsadók Nemzetközi Szakmai Egyesülete. Budapest, 2012, p. 69. (Split of dangerous goods in rail transport by goods classes. In: International Professional Association of Safety Consultants, yearbook of Dangerous goods 2011, Hungary.)
- Veszélyes áruk vasúti szállításának ellenőrzése 2012*. MI NDGDM, Annual report 2012. (Inspection of the rail transportation of hazardous goods.)

The NATO Policy on Cyber Defence: The Road so Far

SZENTGÁLI Gergely¹

In recent years news about cyber attacks targeting states, corporations and individuals have been steadily increasing. There is no doubt that more and more emphasis is being placed on the threats emerging from cyberspace. Security experts agree that the question of cyber security has become one of the most important challenges of the new millennium. The aim of this paper is to examine the issue from NATO's perspective by analyzing the accomplishments to date - the road so far.

Introduction

NATO faced cyber warfare for the first time during the 1999 air campaign in Kosovo. The military intervention, called operation *Allied Force*, started on 24 March 1999 against the forces of Slobodan Milošević. The campaign in itself was questionable since the UN Security Council did not give permission to begin the assault, despite this, military operations began. Shortly after, Serbian hackers attacked several NATO websites.

Due to the continuous distributed denial of service (DDoS) attacks, NATO websites became repeatedly unavailable for long periods. The Serbian hacker group, called *Black Hand*, who was responsible for these cyber assaults, 'defaced' several governmental websites and tried to break into the NATO command servers. The act was a failure, because they could only manage to get access to the computer networks of the air force, but could not recover any confidential information. Due to the impact of bombing the Chinese embassy in Belgrade, Chinese and Russian hackers joined the cyber attacks against NATO. They also used DDoS and deface attacks on the Alliance and the websites of the US embassy. A Russian hacker group, called *From Russia With Love*, operated as the flagship of these attacks. According to statistics they hacked at least 14 military and governmental websites, working together with Serbian hackers during the 1999 Balkan War.²

Decision-makers were quick to realize the importance of cyber defence in the wake of these events. As a result the Alliance decided to launch its cyber defence program during the Prague Summit in 2002, which included the establishment of the NATO Computer Incident Response Capability (NCIRC).³ The Technical Centre, which operates as the background of NCIRC is capable of detecting intrusions into the NATO networks. It is important to note that the protection of computer systems and the networks of the member states is still the task of the state.⁴

With these developments, the preparation for the key security challenge of the 21st century has begun.

1 Corvinus University of Budapest, Hungary

2 SeBóK (2007) p. 102.

3 *NATO Computer Incident Response Capability*. <http://www.ncirc.nato.int/index.htm> (17.12.2012.)

4 KLIMBURG (2012) p. 181.

First steps

It is indisputable that the biggest impact on the cyber defence policy of NATO was the cyber attacks against Estonia in 2007.⁵ This cyber assault was the first example that showed what cyberwar might look like in reality, and it forced several political and military leaders to think about the importance of cyber security. The Russian-Georgian conflict, which took place one year after, again highlighted information operations and cyber warfare. The demand for the unification of cyber security efforts of the member states formulated at the meeting of defence ministers took place on

14 June 2007. As a result in January 2008 the Alliance accepted the Cyber Defence Policy, with the objective of synchronising this process. The leaders stood for the strengthening of cyber security processes at the Bucharest Summit on 2–4 April, 2008. Beyond the realization of new threats, the decision-makers also declared their intention to fortifying the computer systems of NATO and the future cooperation of states. In the history of NATO, it was the first example of an official framework for the subject of cyber security:

*NATO remains committed to strengthening key Alliance information systems against cyber attacks. We have recently adopted a Policy on Cyber Defence, and are developing the structures and authorities to carry it out. Our Policy on Cyber Defence emphasises the need for NATO and nations to protect key information systems in accordance with their respective responsibilities; share best practices; and provide a capability to assist Allied nations, upon request, to counter a cyber attack. We look forward to continuing the development of NATO's cyber defence capabilities and strengthening the linkages between NATO and national authorities.*⁶

Corresponding to the previous steps the NATO Cooperative Cyber Defence Centre of Excellence (CCD COE) was established. It is indicative that the Centre was set up in Tallinn, Estonia. Beyond this organisation there are 15 further centres of excellence operating, they belong to the Allied Command Transformation (ACT), with the same task to support the experts of the given areas and to develop the capabilities of member states. Nevertheless the Centre is not a part of the command structure of NATO, it is only a part of the military structure. Therefore it is not the Alliance who finances it, but the sponsor nations who do.⁷

The Centre was established with the cooperation of the following countries: Estonia, Germany, Italy, Lithuania, Latvia, Slovakia, and Spain. Hungary joined the effort in 2010 and in November 2011 USA and Poland became supporting members as well.

The responsibility of the Centre includes:

- endorsing the development of the cyber capabilities of member states;
- assisting in elaborating doctrines, concepts and strategies of member states;
- organizing education and other training sessions pertaining to information security;
- analyzing the legal dimension of cyber warfare, taking the necessary steps for drawing the international legal framework.

Therefore the organisation does not represent the offensive cyber warfare capabilities of NATO, rather it wishes to operate as a research and educational centre. One of the priorities is to conduct the aforementioned cyber defence exercises. Such exercises were: *Baltic Cyber Shield 2010*,

5 HUNKEr (2010) p. 9., HAIG (2009) p. 335.

6 *Bucharest Summit Declaration. Issued by the Heads of State and Government participating in the meeting of the North Atlantic Council in Bucharest on 3 April 2008.* Item 47.

7 CSÁNYI, Benedek: *A NATO Kibervédelmi Kiválósági Központja*. http://www.biztonsagpolitika.hu/?id=16&aid=1148&title=A_NATO_Kiberv%C3%A9delmi_Kiv%C3%A1l%C3%B3s%C3%A1gi_K%C3%B6zpontja (10.01.2013.)

Locked Shields 2012 and *Cyber Coalition 2012*.⁸ The latter based on the attacks against Estonia in 2007. Hungary also participated in this exercise; according to the scenario the attacks targeted the banking system and air traffic control.

Besides the Centre, NATO established the Cyber Defence Management Authority (CDMA) which is subordinated to the Cyber Defence Management Board (CDMB).⁹ The organisation is headquartered in Brussels and it is tasked with directing the centralized Alliance-wide cyber defence; responding to attacks against NATO and its member states and supporting national cyber defence on a member state level. Furthermore, subordinated to the NATO Computer Incident Response Capability Technical Centre (NCIRCTC), a so-called rapid reaction Team (RRT) was formed, which provides assistance against cyber attacks on a national level, by deploying in the particular country. The decision making body of the organisation is the CDMB, only this board can authorize these deployments. The core of RRT is constituted of a group of experts whom can be supported by further NATO professionals if the given case requires it. By the end of 2012, the RRT capability became operational.

Besides the CDMA, the Computer Emergency Response Team (CERT) was established on a national level. Following the Bucharest Summit, defence ministers agreed that every member state should establish its own CERT, thereby reinforcing and increasing the effectiveness of NATO cyber defence.

Responses to changing challenges

The next step took place on 19–20 November, 2010, when member states adopted NATO's new Strategic Concept in the course of the Lisbon Summit. Besides dealing with the topics of NATO-Russian relations, the operations in Afghanistan, and the missile defence system, attacks coming from cyberspace were discussed as well. As NATO continuously keeps pace with new types of challenges, the issue of cyber security was included in the new Strategic Concept:

*Cyber attacks are becoming more frequent, more organised and more costly in the damage that they inflict on government administrations, businesses, economies and potentially also transportation and supply networks and other critical infrastructure; they can reach a threshold that threatens national and Euro-Atlantic prosperity, security and stability. Foreign militaries and intelligence services, organised criminals, terrorist and/or extremist groups can each be the source of such attacks.*¹⁰

According to this, member states must be prepared for attacks which could be linked to both state and non-state actors. In line with these steps the so-called Global Commons project was launched, supervised by the Allied Command Transformation. The project is concerned with geographical and virtual dimensions which cannot be associated with any specific country; however, they play a crucial role in NATO's security. Such dimensions include airspace, outer space, oceans and seas, and cyberspace itself.¹¹ Out of these domains cyberspace is the most complex, given that it is basically composed of virtual elements, however, the possession of tangible, physical assets is required to implement information operations. This is the complexity which gives vulnerability to cyberspace.¹²

- 8 Not all these exercises were necessarily conducted by the Centre.
- 9 *Nato sets up Cyber Defence Management Authority in Brussels.* <http://www.computerweekly.com/news/2240085580/Nato-sets-up-Cyber-Defence-Management-Authority-in-Brussels> (11.01.2013.)
- 10 *Active Engagement, Modern Defence. Strategic Concept for the Defence and Security of the Members of the North Atlantic Treaty Organisation adopted by Heads of State and Government in Lisbon, 2010.* Item 12.
- 11 *Assured Access to the Global Commons.* <http://www.act.nato.int/globalcommons> (28.01.2013.)
- 12 BABOS (2011) p. 42.

The defence ministers of the member states amended the Cyber Defence Policy in line with the new Strategic Concept during their meeting on the 8–9 June, 2011 in Brussels. Besides the new Policy they also adopted the Action Plan, which essentially put theory into practice. While the newly adopted Policy itself is not public, certain points were disclosed in the press:

- the leaders of the member states recognized that cyber defence is indispensable for collective defence and crisis management;
- prevention, resilience and the protection of IT equipment is of utmost importance for NATO and the member states;
- the goal is to develop cyber capabilities and to protect NATO's own network through centralized security;
- to help the member states to reach a minimal level of cyber defence, reducing the vulnerability of national critical infrastructure;
- cooperation with other partners, international organisations, the private sector and academia.¹³

The organisational reform within NATO has changed the composition of cyber defence bodies as well. The most important decision-making and executive bodies in the current structure of NATO are the following:

- Naturally, the main policy making body remained – as in all other matters, including cyber defence – the North Atlantic Council.
- The majority of the tasks pertaining to incident management and prevention provided by NATO Communication and Information Agency (NCIA) became the main body on one hand for the technical and implementation aspects of cyber defence, and on the other hand for the technical support for any missions undertaken by the member states of NATO itself. The agency, which was created early July 2012, functions as the successor to NATO Consultation, Command and Control Agency (NC3A). Its priority objective is to bring NATO bodies under centralized protection. Its functions related to cyber defence are managed through NATO Computer Incident Response Capability Technical Centre.
- The Defence Planning Committee is continuously submitting proposals to the Council, fundamentally pertaining to defence-related issues, thus the ideas and plans developed by them have a great significance in the field of cyber defence as well.

It is also important to emphasize that cyber defence has become an integral part of the defence planning process of NATO.¹⁴ In March 2012 the decision-makers voted for a €58 million to upgrade the network security of NATO, and to modernise its existing infrastructure; all executed involving the private sector, coordinated by the NATO Communication and Information Agency (back then known as NATO Consultation, Command and Control Agency).¹⁵ The investment project was also intended to allow the aforementioned Computer Incident Response Capability to reach full operational capability by the end of 2012. Furthermore, a Cyber Threat Awareness Cell was set up, which is tasked with pooling intelligence and to facilitate the counteractions to such attacks.¹⁶

13 *Defending the networks. The NATO Policy on Cyber Defence.* www.nato.int/nato_static/assets/pdf/pdf_2011_09/20111004_110914-policy-cyberdefence.pdf (28.01.2013.)

14 *The Secretary General's Annual Report 2011.* http://www.nato.int/nato_static/assets/pdf/pdf_publications/20120125_Annual_report_2011_en.pdf. p. 10. (28.01.2013.)

15 *NATO signs contract for Cyber Defence.* http://www.nato.int/cps/en/SID-CA2E493B-54BE65CB/natolive/news_85034.htm (28.01.2013.)

16 KOVÁCS (2012) p. 308.

The Alliance held its 25th summit in Chicago, on 20–21 May, 2012. The main themes of the summit included the review of defence and deterrent capabilities, how the Smart Defence concept could be improved, the question of withdrawal from Afghanistan, and the evaluation of the military operation in Libya. Naturally, the issue of cyber defence was also raised, and after the summit the stance on this question was published:

Cyber attacks continue to increase significantly in number and evolve in sophistication and complexity. We reaffirm the cyberdefence commitments made at the Lisbon Summit. Following Lisbon, last year we adopted a Cyber Defence Concept, Policy, and Action Plan, which are now being implemented. Building on NATO's existing capabilities, the critical elements of the NATO Computer Incident Response Capability (NCIRC) Full Operational Capability (FOC), including protection of most sites and users, will be in place by the end of 2012. We have committed to provide the resources and complete the necessary reforms to bring all NATO bodies under centralised cyber protection, to ensure that enhanced cyber defence capabilities protect our collective investment in NATO. We will further integrate cyber defence measures into Alliance structures and procedures and, as individual nations, we remain committed to identifying and delivering national cyber defence capabilities that strengthen Alliance collaboration and interoperability, including

through NATO defence planning processes. We will develop further our ability to prevent, detect, defend against, and recover from cyber attacks. To address the cyber security threats and to improve our common security, we are committed to engage with relevant partner nations on a case-by-case basis and with international organisations, inter alia the EU, as agreed, the Council of Europe, the UN and the OSCE, in order to increase concrete cooperation. We will also take full advantage of the expertise offered by the Cooperative Cyber Defence Centre of Excellence in Estonia.”¹⁷

In addition to the resolution at the summit, a document relating to defence capabilities was released, in which cyber capability were displayed as a vital military capability.¹⁸

Cyber attacks and Article 5

It is undeniable that the relationship between international law, law of armed conflicts, Article 5 and attack coming from cyberspace are vague at best. The evaluation and construction of the legal framework of cyber crimes and cyber attacks are pending issues. According to the new Policy, an occurring cyber attack constitutes a political attack, and therefore it does not fall under the provision of Article 5; under this policy the response has to be political in nature as well. After such an attack, decisions lie with the leader of NATO and the member states, not with the commanders of the reaction forces. In other words, NATO retains a degree of resilience in how to manage a crisis which includes a cyber component.¹⁹

A major result is the *Tallinn Manual*,²⁰ written by the Cooperative Cyber Defence Centre of Excellence, which is the first attempt to agree on the international legal framework of cyber warfare. The manual itself is the result of three year long research; it does not qualify as an official NATO doctrine, but rather wishes to be an advisory, guiding text. The document tries to cover all fields

17 *Chicago Summit Declaration. Issued by the Heads of State and Governments participating in the meeting of the North Atlantic Council in Chicago on 20 May 2012.* Item 49.

18 *Summit Declaration on Defence Capabilities: Toward NATO Forces 2020.* http://www.nato.int/cps/en/natolive/official_texts_87594.htm (26.01.2013.)

19 JOuBErT (2012) p. 5.

20 *The Tallinn Manual.* <http://www.ccdcoe.org/249.html> (28.01.2013.)

of international law, with an emphasis on the relationship between the right to wage war (*jus ad bellum*), the applied law in war (*jus in bello*) and cyber warfare.

experts confirm and experience also shows that there is no need to create an automatic mechanism to resolve such issues; each one should be examined on a case-by-case basis, and the nations concerned would decide whether they classify the particular cyber-attack as an armed attack.²¹

Recommendations

Taking into account the information aforesaid, I formulated the following conclusions and recommendations in relation to NATO's cyber warfare aspirations:

- **Up-to-date knowledge, up-to-date systems.** It continues to be crucial that the necessary financial resources be in place for the maintenance and development of the IT infrastructure. Only the most recent technology and the latest systems can be competitive nowadays. Besides maintaining the various systems, it is also important that professionals themselves should have up-to-date knowledge as well; therefore forums where experts can share their latest experiences are of critical importance. For this reason, the flow of information should continue to be a priority.
- **Offensive capabilities and deterrence.** The new Policy puts the emphasis on defensive. However, it should be worthwhile and timely to map the feasibility of any counter strikes, and to establish a significant offensive capability. The US strategies already treat cyberspace as an existing dimension of war, and for that reason they consider the training of relevant forces important; in other words, the demand for a strike force emerged.²² Officially NATO does not have offensive cyber capabilities – this is exactly why it came as a surprise that several military leaders supported a pre-emptive strike through cyberspace during the Libyan intervention.²³ Although it is likely that this plan (which was later rejected) would have been implemented by US forces, it would have also been a great opportunity for NATO to test itself in this field. Relevant forces need to be trained to successfully carry out operations in cyberspace even during an enemy attack.²⁴ Moreover, there are some⁸⁷ researchers who believe that the development of such high level offensive capabilities could serve as a similar deterrent as did nuclear weapons in the Cold War and even today.²⁵
- **Cooperation**
 - *More widespread cooperation.* It cannot be stressed enough that cooperation with non-state actors is crucial. As it is displayed in the new Policy, NATO should pay serious attention to agents and representatives of different research groups, universities and academies, given

21 HäuSSLER (2010) p. 103.

22 *International Strategy for Cyberspace. Prosperity, Security, and Openness in a Networked World.* http://www.whitehouse.gov/sites/default/files/rss_viewer/international_strategy_for_cyberspace.pdf pp. 20-21. (28.01.2013.)

Department of Defence Strategy for Operating in Cyberspace. <http://www.defence.gov/news/d20110714cyber.pdf> pp. 5-6. (28.01.2013.)

- 23 SCHMITT, Eric – SHANKER, Thom: *U.S. Debated Cyber warfare in Attack Plan on Libya*. http://www.nytimes.com/2011/10/18/world/africa/cyber-warfare-against-libya-was-debated-by-us.html?_r=1 (20.01.2013.)
- 24 HEALEY, Jason – BOCHOVEN, Leendert van: *NATO's Cyber Capabilities: Yesterday, Today, and Tomorrow*. http://www.acus.org/files/publication_pdfs/403/022712_ACUS_NATOSmarter_IBM.pdf p. 7. (25.01.2013.)
- Such demand appeared in the Hungarian Defense Forces as well, see HAIG (2011) p. 26-27.
- 25 For the relation between deterrence and cyberwar see LIBICKI (2009) p. 39-74.

that these sectors could help the cause both on the level of individual member states and of the alliance.

- *European Union*. The European union could be an important partner in the future as well, considering the significant overlap in the membership of the two organisations. In- frastructures are intertwined; hence the protection of those should be a common inter- est of both organisations. In this collaboration the primary partner could be the Europe- an Defence Agency. The agency (which launched a separate cyber defence program in 2011)²⁶ primarily serves as a research workshop, however, it can also act as a partner with other international organisations. Anders Fogh rasmussen, NATO Secretary-Gen- eral also called for the launch of a joint project between the Alliance and the Agency.²⁷

Furthermore, the European Network and Information Security Agency (ENISA) could play a crucial role in the cooperation as well. The agency, in addition to monitoring the common networks of the EU and informing the Commission of any possible threats, is closely connected to the member states as well. The main points of the cooperation mostly include organising joint exercises, sharing relevant experience and holding various confer- ences. This is confirmed by Gábor Iklódy, NATO Assistant Secretary General for emerg- ing Security Challenges, while speaking at a cyber-security conference in May, organized by Microsoft.²⁸ He added that in case of a major attack joint actions would increase the efficiency of the defence; furthermore he did not rule out the joint protection of relevant systems in the future.

- *Cyber defence exercises*. The further implementation of the aforementioned exercises also plays a key role in the development of the cyber defence of the Alliance. These exercises con- tribute to revealing the vulnerabilities in the system, and provide a clear picture on how the participating states are prepared to repeal a possible attack. This means that not only can the collective systems be made more resistant, but also national capabilities could be developed with the focus remaining on prevention.
- *Thinking on a strategic level*. The question of cyber defence policy should not be marginal; it should not be a problem to be dealt with on a lower level. It should be stated that cyber security is a pure national security issue, which we have to think about on a strategic level. It is the obligation of all responsible nations and international organisations to establish the necessary legal and organisational framework and to ensure financial resources, because these attacks could cause extreme damage both to the infrastructure of a nation and indirectly to the economy as well.

Conclusion

This paper examined the development of NATO's cyber defence policy and presented the most important organizations and control bodies.

26 *European Defence Agency Annual Report 2011*. http://www.eda.europa.eu/docs/eda-publications/120404_rpannuel2011_def-web (10.01.2013.)

27 HALE, Julian: *NATO Sec Gen Calls for More EDA-NATO Cooperation*. <http://www.defencenews.com/article/20110930/DEFSECT04/109300304/NATO-Sec-Gen-Calls-More-EDA-NATO-Cooperation> (10.01.2013.)

28 HALE, Julian: *NATO Official Highlights Areas for EU-NATO Cyber Cooperation*. <http://www.defencenews.com/article/20120531/DeFRReG01/305310005/NATO-Official-Highlights-Areas-eU-NATO-Cyber-Cooperation> (28.01.2013.)

To conclude, it can be said that the current direction is beneficial, as it is not only concerned with establishing NATO's central cyber defence – more specifically the protection of its IT sys- tems, networks and infrastructures – but also with the effort on the part of the member states to develop capabilities to ensure their own cyber security.

It is pivotal for the member states to understand the essence of the issue, as the true strength of the Alliance does not lie in itself, but in its constituent nations. That is why it is absolutely neces- sary for the member states to develop and bring their cyber capabilities to the same level.

In the recent years – especially since 2007 – NATO has begun to catch up in the field of cyber defence. Considering the operational capacities of various units and organizations it can be said that NATO in its present form in 2013 is an alliance that can adequately address the threats form cyberspace.

References

Active Engagement, Modern Defence. Strategic Concept for the Defence and Security of the Members of the North Atlantic Treaty Organisation adopted by Heads of State and Government in Lisbon, 2010. Item 12.

Assured Access to the Global Commons. <http://www.act.nato.int/globalcommons> (28.01.2013.) BABOS, Tibor (2011):

„Globális közösterék” a NATO-ban. In: *Nemzet és Biztonság.* 2011/3.

Bucharest Summit Declaration. Issued by the Heads of State and Government participating in the meeting of the North Atlantic Council in Bucharest on 3 April 2008. Item 47.

Chicago Summit Declaration. Issued by the Heads of State and Governments participating in the meeting of the North Atlantic Council in Chicago on 20 May 2012. Item 49. CSÁNYI, Benedek: *A NATO*

Kibervédelmi Kiválósági Központja. http://www.biztonsagpolitika.hu/?id=16&aid=1148&title=A_NATO_Kiberv%C3%A9delmi_Kiv%C3%A1l%C3%B3s%C3%A1gi_K%C3%B6zpontja (10.01.2013.)

Defending the networks. The NATO Policy on Cyber Defence. www.nato.int/nato_static/assets/pdf/pdf_2011_09/20111004_110914-policy-cyberdefence.pdf (28.01.2013.)

Department of Defence Strategy for Operating in Cyberspace. <http://www.defence.gov/news/d20110714cyber.pdf> p. 5-6. (28.01.2013.)

European Defence Agency Annual Report 2011. http://www.eda.europa.eu/docs/eda-publications/120404_rpannel2011_def-web (10.01.2013.)

HAIG, Zsolt (2011): Az információs hadviselés kialakulása, katonai értelmezése. In: *Hadtudomány.* Vol. XXI. 2011/1-2. p. 26-27.

HAIG, Zsolt (2009): Connections between cyber warfare and information operations. In: *Academic and Applied Research in Military Science.* Vol. VIII. 2009/2.

HALE, Julian: *NATO Sec Gen Calls for More EDA-NATO Cooperation.* <http://www.defencenews.com/article/20110930/DEFSECT04/109300304/NATO-Sec-Gen-Calls-More-EDA-NATO-Cooperation> (10.01.2013.)

HALE, Julian: *NATO Official Highlights Areas for EU-NATO Cyber Cooperation.* <http://www.defencenews.com/article/20120531/DeFRG01/305310005/NATO-Official-Highlights-Areas-eU-NA-TO-Cyber-Cooperation> (28.01.2013.)

HÄUSSLER, ulf (2010): Cyber Security and Defence from the Perspective of Articles 4 and 5 of the NATO Treaty. In TIKK, Eneken – TALIHÄRM, Anna-Maria (eds.): *International Cyber Security Legal & Policy Proceedings.* CCD COE Publications, Tallinn. p. 103.

HEALEY, Jason – BOCHOVEN, Leendert van: *NATO's Cyber Capabilities: Yesterday, Today, and Tomorrow.* http://www.acus.org/files/publication_pdfs/403/022712_ACUS_NATOSmarter_IBM.pdf pp. 7. (25.01.2013.)

HUNKER, Jeffrey (2010): Cyber war and cyber power. Issues for NATO doctrine. In: *NATO Defense College Research Paper.* 2010/62.

International Strategy for Cyberspace. Prosperity, Security, and Openness in a Networked World. http://www.whitehouse.gov/sites/default/files/rss_viewer/international_strategy_for_cyberspace.pdf p. 20-21. (28.01.2013.)

JOUBERT, Vincent (2012): Five years after Estonia's cyber attacks: lessons learned for NATO? In: *NATO Defense College Research Paper.* 2012/76. p. 5.

KLIMBURG, Alexander (ed.) (2012): *National Cyber Security Framework Manual.* NATO CCD COE Publication, Tallinn.

KOVÁCS, László (2012): Európai országok kiberbiztonsági politikáinak és stratégiáinak összehasonlító elemzése I. In: *Hadmérnök.* Vol. VII. 2012/2. p. 308.

LIBICKI, Martin C. (2009): *Cyber deterrence and Cyberwar.* RAND Corporation. p. 39-74.

NATO sets up Cyber Defence Management Authority in Brussels. <http://www.computerweekly.com/news/2240085580/Nato-sets-up-Cyber-Defence-Management-Authority-in-Brussels> (11.01.2013.)

NATO signs contract for Cyber Defence. http://www.nato.int/cps/en/SID-CA2E493B-54BE65CB/natolive/news_85034.htm (28.01.2013.)

SEBŐK János (2007): *A harmadik világháború. Mítosz vagy realitás?* Népszabadság Zrt., Budapest. *NATO Computer Incident Response Capability.* <http://www.ncirc.nato.int/index.htm> (17.12.2012.) SCHMITT,

Eric – SHANKER, Thom: *U.S. Debated Cyber warfare in Attack Plan on Libya.* http://www.nytimes.com/2011/10/18/world/africa/cyber-warfare-against-libya-was-debated-by-us.html?_r=1 (20.01.2013.)

Summit Declaration on Defence Capabilities: Toward NATO Forces 2020. http://www.nato.int/cps/en/natolive/official_texts_87594.htm (26.01.2013.)

AARMS (12) 1 (2013) *The Secretary General's Annual Report 2011.* http://www.nato.int/nato_static/assets/pdf/pdf_publications/20120125_Annual_report_2011_en.pdf p. 10. (28.01.2013.)

The Tallinn Manual. <http://www.ccdcoe.org/249.html> (28.01.2013.)

High Level Design of the Flight Control Software for Small VTOL Unmanned Aerial Vehicle

ÁrVAI László¹

The implementation of an on-board flight control system must be preceded by extensive design activity. The software implementation, test and maintenance effort might be significantly reduced by using carefully designed software. The design procedure itself is also a complex activity, several requirements, constraints must be considered in order to generate an appropriate, well detailed and easily implementable design. The design task is even more complicated when the aircraft has some special features like the capability of vertical take-off and landing. In this case the software must be able to handle the diversity of flight modes where the aircraft behaviour in each mode is unique. This article presents the main aspects of the design procedure.

Introduction

The on-board flight control software of any unmanned aerial vehicle must deal with several very complex tasks. Stability, navigation, communication, payload control are just some of the main tasks and integrating all these in on-board software is directly responsible for the safe, reliable, optimal and smooth operation of the aircraft. The software must accomplish its tasks in real-time with the shortest possible response time, using only limited resources.

The implementation work of an on-board flight control system must be preceded by careful and detailed design activity. The requirements must be collected, defined and analyzed, the constraints must be recognized and after making several decisions and compromises the final high level software design can be obtained. The most important factors in software design include configuration, dimensions and geometry of the aircraft.

Aircraft configuration

The aircraft presented here is a small size, fixed wing, canard configuration airplane with tilted engines. The wingspan is less than two meters, the maximum take-off weight is about one and half kilograms.

The engines are ducted fans, located on both sides of the fuselage, assembled on small rotatable sponsons. The ducted fans are driven by brushless electric motors; the energy comes from a Li-Po battery. The computer generated image of the aircraft is shown in Figure 1.

The aircraft has no gears since STOL² and conventional take-off and landing operations are not desired, because the appropriate implementation of these modes will make the control software even more complicated. However, these features might be added later, because they can be very valuable in the case of an emergency landing, when the engine power is completely lost, then the aircraft still can glide and land conventionally. But in the first version only a small landing skid will be used.

¹ National university of Public Service, Budapest, Hungary

² STOL – Short Take-Off and Landing

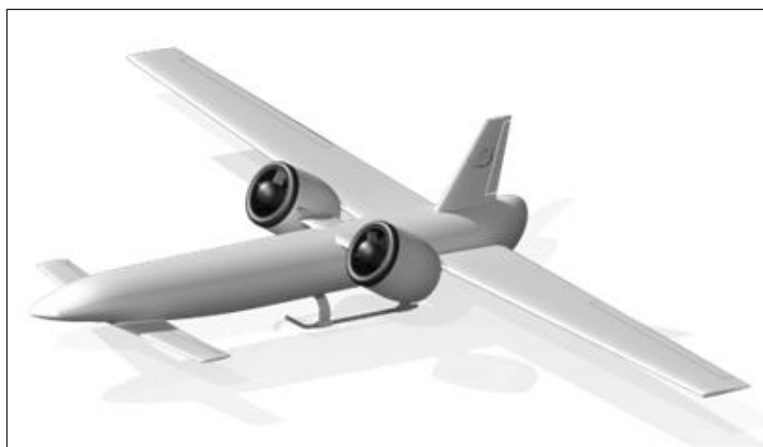

Figure 1. The Cygnus UAV (computer generated image)

Árvai László: High Level Design of the Flight Control Software for Small vTOL Unmanned aerial vehicle position to slightly over vertical position. The picture also shows all conventional control surfaces (ailerons, rudder, and elevators). Because of the lack of conventional landing capability, other surfaces (flaps, speed breaks, etc.) are not required. The control surfaces will be used in horizontal flight mode (when wings produce total lift). In hovering mode (when ducted fans produce the lifting force) vectoring controls will be used.

The only planned payload at the moment is an on-board camera, sending its image wirelessly to the ground station, so obviously the only possible mission for this uAV is an image reconnaissance mission.

Flight profile

The flight of the UAV is composed of several phases. Each phase has different or at least slightly different requirements for the flight control. A typical UAV mission flight profile is shown in Figure 2. The profile picture is based on a flight profile of a fixed wing UAV³ with an adaptation for VTOL uAV.

The UAV follows a predefined flight path, where each waypoint is defined by the position (latitude and longitude), altitude and speed. The waypoint can be defined in the ground station software and uploaded to the on-board flight control electronics via wireless link. After uploading waypoint data the uAV is capable of following its designed path autonomously.

The flight starts with a vertical take-off (cf. 1 in Figure 2) and continues with the transition to horizontal flight (1-2). Even the airframe enables a conventional or short take-off, though it is not planned at the moment. In this mode the main task of the flight control software is maintaining the stability of the aircraft, adjusting the engine RPM to achieve the required lifting force and vertical speed, controlling the transition phase between vertical and horizontal flight until a safe forward flight condition is reached (all lifting force is generated by the wings).

The flight continues with horizontal flight (3-5) where the most important tasks (besides the attitude stability) are the following: regulating the speed, altitude and heading in order to follow the predefined flight path.

3 KurNAZ-CETIN-KAYNAK (2009)

The next phase is either the loiter or hover phase depending on the type of reconnaissance task. The flight control requirements in hovering mode are similar to those in vertical take-off phase and the requirements in loiter mode are the same as in horizontal flight mode. Phases (3-9) might be repeated several times in the case of multiple target areas.

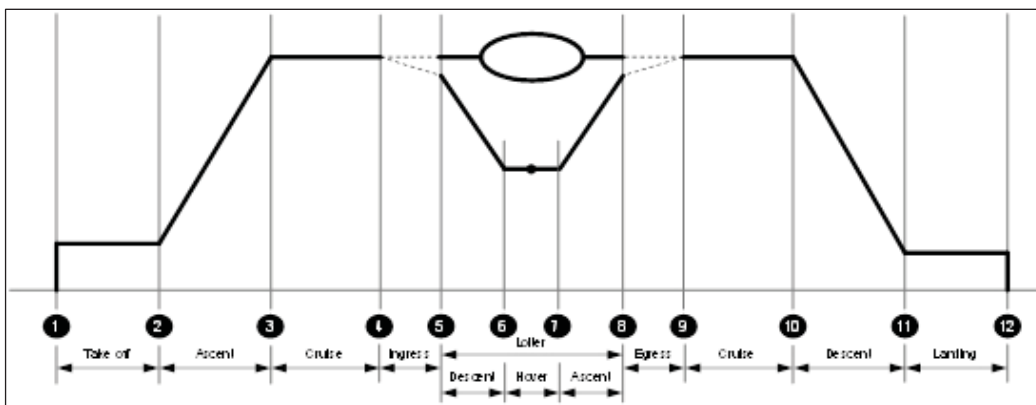

Figure 2. Typical mission flight profile

At the end of a flight similar phases follow each other like the ones at the beginning, but in reverse order. The requirements are basically also the same. There is only one exception, since to obtain completely autonomous landing the clearance of the landing area must be verified and continuously monitored. However, this also makes the flight control system more complicated, therefore this feature will be omitted and even the landing is done automatically, human supervision is required for the sake of safe operation.

In the case of completely autonomous operation, especially in urban regions, collision free path planning is essential.⁴ The cruise/loiter phase of the flight path can be further optimized using soaring/thermals.⁵ Szabolcsi derived flight paths geometry for different flight phases,⁶ and derived requirements for a given flight profile. However, application of the very high level of autonomous operation mentioned earlier in the article is out of the scope of the current research activity. The main goal is to achieve flight stability in VTOL operation and the stable transition from/to horizontal flight autonomously.

Flight control laws

Besides handling each phase of the mission profile, the flight control system must be able to choose the appropriate flight mode (mission goal) as well. There are three modes (or laws) summarized in Table 1.

- 4 NARAYAN (2008)
- 5 ALLEN (2007)
- 6 SZABOLCSI (2010a), SZABOLCSI (2010b)

<i>Mode</i>	<i>Primary control target</i>	<i>Mode selection criteria</i>
Normal law	maintain aircraft stability and follow predefined flight path	This is the default flight mode
Manual law	no stability and flight path control, only fly by wire control	Initiated by the ground crew
Alternate law	maintain aircraft stability, fly to home, or crash land the aircraft	Initiated by the detection of on-board serious failure

Table 1. Flight control laws

Normal law

The normal law is the default flight control law. A manual or alternate flight control law can override this mode but the system can only return to this mode from manual law. In normal flight mode attitude stabilization and navigation are done automatically based on the predefined mission profile. The block schema of this mode is shown in Figure 3.

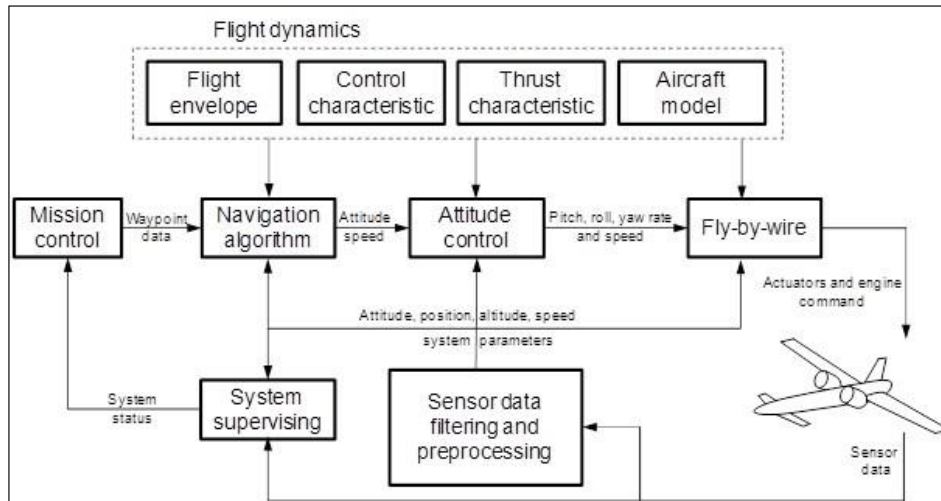

Figure 3. Blockschematics of normal flight control mode

The mission control module defines the actual flight goal based on the preloaded mission flight path and the actual status of the aircraft. It gives the next waypoint information to the navigation algorithm.

The navigation algorithm designs the flight path based on the current position and the next desired waypoint information of the aircraft. It sends attitude and speed information to the attitude control module.

The attitude control stabilizes the aircraft in any flight mode, and from the target attitude and speed information it calculates the necessary pitch, roll, yaw rate (acceleration) and speed information and passes it to the fly-by-wire system.

The fly-by-wire system translates the desired pitch, roll, yaw rate and speed request into the actuator and engine control values.

The feedback loop starts with the sensors located on the aircraft. The sensor data is validated,

scaled, filtered, pre-processed and combined by sensor data filtering and the pre-processing module. The module uses several sensor's data (gyro, acceleration, magnetic field, differential (Pitot tube) and absolute (altitude) air pressure, GPS and system monitoring sensors such as current, voltage, temperature, etc.) in order to generate the attitude, speed, altitude, position and system status information for other modules.

The system supervisor module is continuously monitoring the whole system, analyzing the dataflow between modules. If it detects serious anomalies it analyses the seriousness of the failure and makes its suggestions to the mission control module.

There are additional modules providing information about the flight dynamic of the aircraft. The flight envelope information is used by control modules to stay within the safe aerodynamic conditions. The control and thrust characteristic

is required for the fly-by-wire system to calculate actuator and engine control parameters for the desired attitude and speed changing. The aircraft model is also used by the fly-by-wire system in order to handle various flight conditions (horizontal, hovering, transition), i.e. based on the aircraft behaviour the control system can decide which actuator type (aerodynamic, vectoring) should be used in the current situation.

Manual law

The manual flight control law is initiated by the human operator from the ground station. The human operator is allowed to switch back to normal mode or the system will switch to normal mode when the radio link used for control breaks. In this mode the control of the aircraft can be taken over by a human operator. The flight control system will neither stabilize the aircraft, nor follow the waypoints. However, it helps the human operator with a fly-by-wire mode and flight envelope protection. The block schema of this mode is shown in Figure 4.

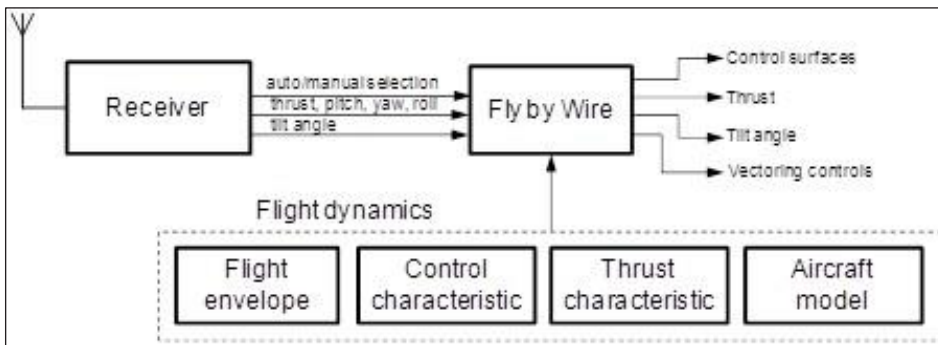

Figure 4. Block schematic of manual flight control mode

The command from a human operator is received via either the telemetry/command communication channel or using a separated 'backup' receiver. Commands issued by the operator are the same as usual aircraft controlling commands, they command the throttle (thrust), pitch, yaw and roll. There is only one special command - because of the VTOL operation- the tilt angle of the engines, i.e. the ratio of the expected lifting force generated by wings or engine thrust. The real tilt angle is determined by the fly-by-wire system.

The command from the ground operator is processed by a fly-by-wire system. There are two important reasons for applying this system. On the one hand, controlling any aircraft from the ground, without

having the real sensation of flight is more difficult, it is relatively easy to break the flight envelope of the aircraft and loose control of it. With an active flight envelope protection this can be avoided.

On the other hand, the VTOL aircraft has different behaviour in different flight modes (horizontal vs. hovering) and these behaviours are blended in the transition stage, however, the operator expects only one controlling method. For example in the normal (horizontal) flight mode the yaw rate is controlled by the aerodynamic force of the vertical stabilizer and rudder. However, in hovering mode, when the airspeed is close to zero all aerodynamic surfaces are useless. In this mode vectoring controls are necessary, i.e. differentially tilting the engines will give the appropriate yaw moment. So the fly-by-wire system needs to convert any rudder (yaw) input to differential tilt angle. Moreover, tilting the engines will reduce the vertical component of the engine thrust (i.e. the lifting force) so it also should be compensated for by increasing the engine power (RPM). So the fly-by-wire system receives only the intention of the operator and decides automatically the best actuator settings for the required operation. To achieve this goal the fly-by-wire system needs to know the actuators/controls characteristics, engine characteristics and the aircraft characteristics, all these should be determined by computer simulation and actual test measurements.

Based on this information the fly-by-wire system can control all aerodynamic surfaces, vectoring controls, engine thrust and engine tilt angle according to the request from the human operator.

Alternate law

Alternate flight control law is initiated by the system when it detects a serious failure. In this mode the aircraft abandons the mission goals and tries to land safely. The flight control system still tries to stabilize the aircraft attitude, but instead of following the flight plan it switches to

'go home' mode, i.e. it goes back to the starting position using the shortest possible route. If the aircraft attitude cannot be controlled because of a failure, or returning to the starting point is not possible because of the lack of energy, it tries to crash land the aircraft in order to minimize the loss.

The alternate law can be overridden by the manual mode, but normal mode will not be enabled until the system is restarted.

Operation system

The flight control system is definitely a real-time system, because response time constraints are very strict, the control must be able to respond to any aerodynamic disturbances quickly in order to maintain stable flight. Thus, the design procedure must start with the assumption of using real-time software architecture. The most plausible starting point of the real-time system design is choosing a real-time embedded operation system. The embedded operation system plays an important role in the complete system, the reliability, response time, complexity and power consumption of the flight control system depends very much on the choice of the embedded operation system. However, in the case of small size uAV, when the computing power and the complexity of the embedded processor is limited, the choice of the operation system is not so straightforward. Some operation systems are able to run on hardware with limited resources.⁷

The procedure of selecting them is also explained there. However, there is another possibility.

7 MARIONI et al. (2006)

Once we have decided to design and build a modular system⁸ (where the module borders are defined among functionality and the module is composed of software and hardware together) we might avoid using real time operation systems. When a module has one or only a few well defined tasks a pre-emptive task scheduler, extended with interrupt driven real time drivers, might do the job as well. The interrupt based drivers give quick responses to any external signal while the microcontroller has only a few well defined tasks. The pre-emptive task schedules give a reasonable response time without the expense (resource) and complexity of the real time operation systems.

The main modules are listed in Table 2.

<i>Module</i>	<i>Software Function</i>
Main board	System supervising, running flight control tasks
IMu	Complete inertial system, filtering and pre-processing sensor signal
GPS	Pre-processing GPS information
Communication	Communication with the base station, on-board data logging
Engine control	Controlling the engine power and monitoring the engine condition

Table 2. Primary modules

The main board as hardware is responsible for the complete interfacing of the modules (communication, power supply) and as a software module it runs the system supervising and primary flight control tasks. It has direct connection to the actuators and it has most of the system monitoring sensors.

The flight control related sensors are located on other modules, the most important one is the IMu module. This module contains the complete inertial system with three axis gyro, acceleration, magnetic sensors and the absolute air pressure sensor (altitude, vertical speed). A differential air pressure sensor (airspeed) can also be connected. It runs the appropriate sensor data processing and filtering algorithms in order to produce the aircraft attitude, altitude, and speed, etc. data.

The other important sensor module is the GPS module. It receives GPS data pre-processes, and parses these and sends them to the main board.

The communication module is responsible for maintaining the wireless link with the base station. The link is used for sending telemetry data and receiving commands. It also logs all telemetry data on-board for off-line analysis and visualization.

The engine control module controls the engine thrust. It drives the brushless electric motors and monitors its RPM and current (power) consumption. The power consumption monitoring is important for the estimation of the remaining energy stored in the battery.

The primary modules together are able to fly the aircraft but adding other modules might be necessary. The auxiliary modules are listed in Table 3.

8 ÁRVAI (2012)

<i>Module</i>	<i>Software Function</i>
Backup communication	Backup communication channel, lower bandwidth than a normal communication channel and mainly used for manual control of the aircraft

AARMS (12)1 (2013) 98

Payload	Controlling the payload, monitoring its functionality and power consumption
---------	---

Table 3. Auxiliary modules

There are several possible auxiliary modules, but only two of them are listed in the table. The backup communication module is mainly used for manual control of the aircraft, usually it has lower bandwidth. However, it also may be the case that it has no telemetry data sending capability or its capability is quite limited, so it can be used only for line-of-sight operation of the aircraft.

The aircraft usually has a payload, in a simple case it might be only a video camera and transmission system, but it also can be complete SIGINT/MASINT equipment. In any case the payload needs power and control. usually the payload has a separate channel for communicating with the ground station.

Software structure

Based on the description given above, the high level software structure can be designed. At this level the software modularity is not shown, because from the designer points of view the module division and the intermodule communication are not so important, however, a complete overview of the necessary functions is required. The complete system overview is given in Figure 5.

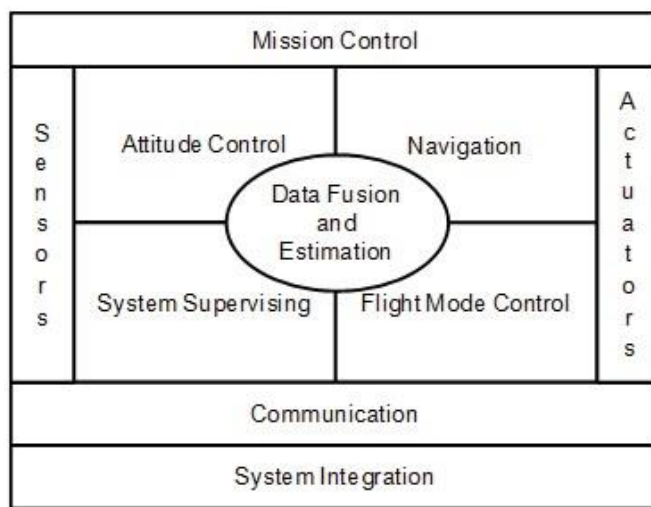

Figure 5. Software structure

At the top of the software structure the mission control system is located. This module has the highest overview of the system and it makes the highest level of decision. It continuously monitors the aircraft condition and determines the current goal for the aircraft and passes this information for all other subsystems. In normal flight control modes it follows the predefined mission profile, so the aircraft visits the predefined waypoints and executes its planned task there. In the case of

an emergency it makes a decision about the safety action to be made, cancelling the mission and bringing the aircraft home or crash landing it in order to minimize the damage.

The sensor subsystem is responsible for the data processing of all sensor data. The processing starts with the data validation. The stability of the communication channel of the sensor (either it is analogue or digital) is continuously monitored, the sensor data compared with the desired range of the sensor. If sensor communication seems to be broken or data seems to be out of range, this piece of information is passed on to the system supervisor module. When the sensor data is valid it is further processed, cleaned, filtered or even combined (data fusion). For example, in the case of inertial sensor data, the gyros, accelerations, magnetic field sensors data or even the GPS data are combined in order to produce Euler angles or Direction Cosine Matrix.⁹

The attitude control module is responsible for active stability, aircraft directional and speed control. It has all the necessary control loops for providing stability about longitudinal, lateral and vertical axis and controlling the desired angular speed about these axes.

The navigation module is responsible for the flight trajectory planning and optimizing, i.e. to reach all waypoints with minimal energy consumption.

The flight mode control basically belongs to the mission control, however, because of its importance it was separated in the picture. It decides which flight control law should be used and on normal law mode it selects the appropriate phase of the flight profile.

The system supervising module is continuously monitoring the system health. In the case of any significant failure it tries to identify the problem and classifies it based on their danger. For recognizing the failure it uses the information from the

Árvai László: High Level Design of the Flight Control Software for Small vTOL Unmanned aerial vehicle sensor driver about the reliability condition of the given sensor but it also compares sensor values with the expected sensor values based on actuator settings and aircraft model. In the case of less serious problems it tries to adapt the system.¹⁰

The actuator control module is responsible for translating desired angular speed about the aircraft axes into the control surface or vectoring control deflection. In manual flight control law this module serves as a flight-by-wire system.

The data fusion and estimator module works strongly together with the system supervising module. It continuously monitors the sensor and actuator data flow. Any significant difference between the measured (sensor) data and the expected behaviour of the aircraft (actuator data) can have only two reasons. One is the sensor/actuator/system failure, which is handled by the system supervising module. The other reason can be some external effect which is not measured directly by sensors. For example, if the aircraft speed vector measured by the inertial system is not coincident with the speed vector measured by the GPS it might show the existence of a crosswind. The direction and speed of the crosswind can be calculated comparing the two kinds of information.¹¹

The communication subsystem is responsible for the telemetry data sent to the base station and it also receives commands from it. The communication must be reliable and secure, both requirements must be handled by high importance when the communication protocol and software are designed. The on-board data logging is also handled by the communication module (however, it could be handled somewhere else), since the communication module has all system data for telemetry data sending.

The system integration part of the software is responsible for handling all on-board devices

9 GEORGE, Michael – SUKKARIEH, Salah: Tightly Coupled INS/GPS with Bias Estimation for uAV Applications. <http://prism2.mem.drexel.edu/~vefa/research/HeliExtLoadStabil/relevantPapers/imu/george.pdf> (01.06.2012.)
PEREZ-D'ARPINO et al. (2011)

10 IPPOLITO – YEH (2007)

11 SIR (2003)

which are not handled by the actuators module. One such task is power management (energy consumption measurement, overload monitoring and handling) and payload control.

Conclusions

Creating on-board flight control software for any UAV is a very complex task. The requirements are diversified and the available resources are very limited and the complete system must be a real time system with a very robust construction. Therefore precise and extensive design work should be done first. In the high level design phase the aircraft purpose, characteristics, typical mission profile must be defined, and special requirements should be collected. Next the control laws should be defined and necessary data flow schema of each mode should be drawn.

The best solution would be to use real-time operation systems, but sometimes the limited resources or the complexity of such a system makes it impractical to use. In such cases a modular design (distributing tasks among several processors) might provide a good solution.

Finally, the high level software structure can be created. The result of high level system design provides all major software subsystem's description, explains their main functionality and defines dataflow between them.

All information created in the high level design procedure will serve as basis for lower level software design.

References

1. KURNAZ, Sefer – CETIN, Omer – KAYNAK, Okyay (2009): "Fuzzy Logic Based Approach to Design of Flight Control and Navigation Tasks for Autonomous unmanned Aerial Vehicles" In: *J Intell Robot Syst*, p. 229-244.
2. NARAYAN, Pritesh (2008): "unmanning uAVs – Addressing Challenges in On-Board Planning and Decision Making" First International Conference on Humans Operating unmanned.
3. ALLEN, Michael J. (2007): "Guidance and Control of an Autonomous Soaring uAV" NASA, Dryden Flight Research Center.
4. SZABOLCSI róbert (2010a): "uAV Flight Path Conceptual Design" In: *Proceedings of the 16th International Conference "The Knowledge-Based Organization – Applied Technical Sciences and Advanced Military Technology"*, pp. 519-524, November 2010.
5. SZABOLCSI róbert (2010b): "Worst Case Flight Scenario for unmanned Aerial Vehicle in D3-Missions" In: *Proceedings of the 12th Mini Conference on Vehicle System Dynamics, Identification and Anomalies*, pp. 351-361, November 2010.
6. MARIONI, Mauro – FACCHINETTI, Tullio – BUTTAZZO, Giorgio – FRANCHINO, Gianluca (2006): "An Embedded real-Time System for Autonomous Flight Control" *ANIPLA*.
7. ÁRVAI László (2012): "Design of the on-board flight control electronics of an unmanned aerial vehicle" In: *Tavaszi szél konferenciakötet*, Budapest. pp. 366-372.
8. GEORGE, Michael – SUKKARIEH, Salah: Tightly Coupled INS/GPS with Bias Estimation for uAV Applications. <http://prism2.mem.drexel.edu/~vefa/research/HeliExtLoadStabil/relevantPapers/imu/george.pdf> (01.06.2012.)
9. PEREZ-D'ARPINO, Claudia – VIGOURoux, Damian – MEDINA-MELENDÉZ, Wilfredis – FERMIN,

- Leonardo (2011): "Development of a Low Cost Inertial Measurement unit for uAV" *IEEE International Conference on Process Automation, Control and Computing*, pp. 178-183, 2011.
10. IPPOLITO, Corey – yEH, yoo-Hsiu (2007): "Neural Adaptive Flight Control Testing on an un-manned Experimental Aerial Vehicle" *AIAA Infotech@Aerospace*. <https://doi.org/10.2514/6.2007-2827>
 11. Sír, Cristián (2003): *real-time Wind Estimation and Display for Chem/Bio Attack response using uAVData*, Master thesis.

The Role of the Hungarian National Police in the Transformation Process of the Turkish Border Policing System EU Twinning Project in Turkey

KOVÁCS Gábor¹

Hungary has always played a leading role in the theoretical and practical implementation of the Schengen Acquis and the Schengen extension process. One of the best examples may be the implementation of the European Union funded twinning project titled “Action Plan on Integrated Border Management-Phase 1”. The aim of this essay is to give additional information to the present border policing situation and the border security organizations in Turkey. We will look at the process of establishing a new Border Guard organization and the joint efforts performed by the project and the beneficiaries in the launch of the new Integrated Border Management System (later on IBM) in the country. We can conclude that the IBM project combined the best respective EU theories and practices successfully.

Hungary has long since paid strong attention to, and made significant efforts in the implementation of the integrated border management (IBM) concept² and the Schengen Acquis, together with other candidate countries of the European union. The experience of the experts of the Hungarian National Police is recognized throughout Europe. The “Action Plan on Integrated Border Management-Phase 1” for Turkey might serve as a good example for that.³

The aim of this project was to establish a new Border Guard organization together with Turkish experts and stakeholder organizations and to launch a new Integrated Border Management System all over Turkey. Based on the cutting edge research results and practical skills elaborated in the European union, this IBM Phase-1 project successfully combined the best theories and practices in achieving these aims.

The Turkish Government has been actively pursuing its own National Programme for the adoption of the Schengen Acquis in the course of the accession progress to the European union and in response to the obligations of the Eu and its Member States. However, the objective of the approximation process was not only to implement the amendments in the Turkish legal system. It was just as important for both sides to strengthen all those organizations responsible for the law enforcement or the implementation of the new border procedures and formalities. This institutional and organizational capacity building process was seen as essential in ensuring that Turkey would successfully perform their transition to the standards, norms, expectations and obligations of the respective administrations of the Eu Member States.

The expected outputs of the project were to develop and strengthen Turkey’s institutional, organizational and technical capacities in line with the Eu’s integrated border management (IBM)

1 Email: kovacs.gabor@uni-nke.hu

2 See detailed in the Guidelines for Integrated Border Management in EC External Cooperation, European Commission, Europe Aid, Brussels, 2009.

3 Police Colonel Gábor Kovács Ph.D. has been working as resident Twinning Advisor in Turkey from May 2010 to November 2011.

policy. The legal structures of the Border Security Detachment had to be also aligned with the Eu IBM strategies. The project had to develop the relevant legislation in draft and the existing institutional framework in Turkey and had to be amended deliberately. All relevant staff needed to be properly trained to improve the organizational capacity for Border Security Detachment and to ensure that the Turkish authorities are capable of implementing their IBM strategy. Proposals were developed for strengthening the overall capacity of the Border Security Detachment to implement the Eu’s IBM strategies.

When Turkey obtains membership to the Eu, the country’s eastern borders will be the external south-eastern borders of the Union. Turkey will have difficulties in providing comprehensive border security standards even with implementation. Turkey is a country that is characterised by long mountainously steep land borders on the east and southwest as well as long coastlines on her south, north and west. The country also serves as a crossroads of the Middle East, Asia and Europe. Due to this geographical location a strong border control and safeguarding organization is needed. Turkey has in total 2,949 kilometres of land borders and a rugged land configuration. About 65% of her land borders are in mountainous regions; its borders in the east and southeast lie on mountains. Besides, in some border regions, the climatic conditions are very harsh, where winter may last up to six months.

Turkey plays a significant role in the east-west streaming of illegal migration. During the European accession process Turkey has been achieving important results in the transformation of the current border control system⁴. In previous years, the country used to be considered as a migration emitting country. This view has changed and it has rather become a transit country. The main orientation of the illegal immigration follows an east-west direction, with the main stream of illegal migrants leaving the country for Bulgaria and Greece, from where they attempt to go to Western European countries.

Crime pattern analysts at Frontex recognized this trend, which triggered the first deployments of Frontex’s quick-reaction

Kovács Gábor: The role of the Hungarian National Police in the transformation process of the Turkish Border...

forces there. This Eu Agency has been organizing and implementing a variety of border policing operations at the Greek side of the Greek-Turkish border line. According to the results of such operations a certain decrease may be measured in the number of illegal border crossings during the operations and some subsequent periods.

The European union has a common security interest that sets, for the candidate countries such as Turkey, requirements involving the capabilities of the border control system. Thus Turkey has had to strengthen their border control to a proper level and at the same time the used methods of border control have had to conform to Eu and Schengen Acquis standards as well.

What was the previous border control system in Turkey and what changes had to be performed?

Turkish authorities involved in border control and surveillance

At the project inception, five dominant organizations dealt with border control: the Turkish Land Forces and the National Police in a wider sense of general security, as well as the Gendarmerie, the Coast Guard and the Customs Department have their specific law enforcement area of responsibility concerning the border.

Moreover, many other authorities fulfil certain functions with the border traffic control with or without permanent representation at the border area. One of the most significant bodies is the Ministry of Health and their subsidiaries, dealing with general human health risk detection and epidemic prevention. The Ministry of Agriculture has veterinary and phytosanitary inspectors at

-
- 4 Border control consists of border guarding ("green" and "blue" border surveillance), border traffic control, and border related criminal investigation – see details in Zagon Csaba: Border traffic risk assessment. In. AAIRMS Vol. 11, No. 2 (2012) pp.273–285.

the borders as well. They also play an important role in food safety and protection of the country's flora and fauna.

Accession to the Eu was set as a strategic objective of Turkey. Among many conditions Turkey needs to achieve membership is to develop their border control system, and they are supported by the Eu through several assistance forms. The Eu institutions and the individual member states have been providing significant assistance and have launched twinning projects as well.

The philosophy of the twinning projects is that the beneficiary country's experts and the assisting member state's experts work together on achieving the project aims. They develop and implement advanced solutions for the problems that the beneficiary country is facing, which are mutually acceptable for both sides.

The Turkish Land Forces

In the 1980s, due to the increased threat of armed terrorists the Land Forces took over the tasks and responsibilities of guarding the land borders all over Turkey from the Gendarmerie.

According to Law No. 3497, the burden of the land border security and protection were moved under the responsibility of the Turkish Army's Land Forces. The Land Forces' sub-ordinate bases dealing with border guarding dislocate relatively close to the borderline. Due to the specific geo- graphic reasons and other influencing conditions, the network of these barracks was positioned not more than 3-12 km away from the state border. However, the current dislocation is almost completely devoid of risk analysis results. For instance, there are some barracks in a 6-8 hours patrolling distance from the border. Some of them are in fact, positioned on the top of a hill.

In practice, soldiers carry out border protection, and the general method has remained patrolling two-kilometres-wide border security zones. The respective personnel are supplied with technical equipment mostly developed for military purposes (binoculars, night vision devices, radar devices etc.).

At the Iraqi border, the border zone is wider than two kilometres and strengthened by solid minefields and other technical barriers to cause serious difficulties for any kind of movements involving illegal migrants.

The Land Force Command is located in Ankara, but the organization is decentralised and well fragmented into regional and territorial tiers. Individuals intercepted in the border zone by the patrols of the army, will shortly be handed over to the Police for the necessary follow-up procedures. Although there is a significant military role in border surveillance, facts and figures show illegal migrants crossing the Bulgarian and the Greek border, where the procedures have simply proven unsatisfactory. According to the Frontex Situation Centre (FSC) the number of those people who committed successful illegal border crossings is more than significant.

The Turkish National Police

The border traffic control tasks at all border crossing points (land, water, air) are carried out by the Turkish National Police. This organization belongs to the Ministry of Interior's Security Directorate.

The individual border crossing points (BCPs) are under a Sub-Governor or a Governor. Due to the unique administrative structure of Turkey that conserved certain traditions, all law enforcement agencies operating in a particular province are subordinate to the Sub-Governor or Governor. Certainly, the professional management of the BCPs is clearly provided by the

Kovács Gábor: The role of the Hungarian National Police in the transformation process of the Turkish Border...
Police's own management system, however, Governors are entitled to set priorities for law enforcement.

81 provinces cover the jurisdiction area of the Turkish National Police. It includes approximately 400 towns that cover about 8% of the area of the country. The National Police is responsible for the country's internal security and the coordination and implementation of the integrated border security.

In the country there are 1,197 police stations, 756 districts and 81 Provincial Directorates. The central body is located in Ankara; the total number of police staff reaches the figure of 250,000.

This central organization includes the Immigration- and Asylum-; and Border Police Departments, whose main tasks cover the examination of visas, residence permits, and asylum applications. It is also responsible for the reception of asylum seekers and refugees, naturalization proceedings, for the coordination of the national notification system and to take and implement measures against trafficking in human beings.

In June 2010, a system of biometric passports was introduced in Turkey. The passport-related tasks were excluded from the scope of the Police. A civilian unit was set up within the Ministry of Interior and they are dealing with issuing passports.

Police have a Contraband- and Organized Crime Department that deals with, among other tasks, organised illegal migration, smuggling in human beings and human trafficking, as well as performing certain anti-terrorist activities.

The Gendarmerie

The Gendarmerie works according to the Law No. 2803. The Gendarmerie has double the area of responsibility. One of their tasks is like that of a law enforcement organization's they are responsible for the maintenance of security and public order. Their second task is to act as a subordinate organ of the General Staff during emergency and wartime situations and to support the Turkish Armed Forces.

The Gendarmerie forces are subordinates of the Minister of the Interior, but according to this organizational character, they have closer ties to the military organizations than the Police have.

The Gendarmerie forces consist of professional and conscript soldiers, they carry out organizational tasks. The area of responsibility of the Turkish Gendarmerie is to perform extra urban police tasks, so their territory of operation is comprised of 92% of the country. The Gendarmerie is responsible for guarding an approximately 200 kilometre long section of the Turkish - Iraqi border. The section of the Gendarmerie that is committed to the border guarding tasks is composed of conscript soldiers and led by the professionals.

The total number of staff is 150,000, where approximately 6,000 people are involved in carrying out the duties of border policing (guarding).

At the Iranian border, the transfer of border guarding functions to the Army is still in progress today.

The Turkish Coastguard

The Coast Guard, as an armed law enforcement organization, in peacetime is under the Ministry of the Interior, during an armed crisis and wartime this organization belongs to the Turkish Navy.

A sound majority of the organization's staff have served in the Navy. Inter-service mobilization is very common between the two organizations; the Coast Guard is in close contact with the Navy.

The operational area of the Coast Guard covers the coastal waters, which belong to Turkey (Mediterranean Sea, Aegean Sea, Black Sea, Marmara Sea): The total area is 377,172 km².

The organizational structure of the Coast Guard includes a Central Headquarters (Ankara), a Black Sea region Command (Samsun), a Sea of Marmara and Straits Command (Istanbul), an Aegean Sea region Command Headquarters for the Mediterranean region (Mersin), an Air

Headquarters (Izmir), a Training Command (Antalya), and a Supply Command Centre (Istanbul).

The estimated number of Coast Guard staff is 3,250 people; they are all professionals. This organization is only responsible for the maritime borders and does not have power at sea border crossing points. The control of the sea border crossing points is carried out by the Turkish National Police.

Act No. 2692 (2013) defines the main tasks for the Coast Guard. It is the competent law enforcement body on the sea, they are responsible for guarding and protecting Turkey's seas (waters), for the protection of life and property at sea, also in territorial waters their task includes the disarmament of refugees and delivering them to the competent authorities; on the high seas they are entitled to prevent all kinds of smuggling, checking ships and boats, to perform search and rescue activities and also to fulfil certain environmental protection functions.



Figure 1. Turkish Borders and Responsible Organizations in Border Protection

The Customs Service

The Customs Deputy Secretary of State has responsibility in checking of vehicles and goods crossing the borders, in detection of smuggling of commodities and they are responsible for the security of border crossing points.

According to the Customs regulations, the main duty is to prevent, detect and investigate all kinds of smuggling activities at the borders. Turkish Customs is subordinated to the Prime Minister's Office. The customs service has extensive international and domestic cooperation with other organizations. At the border crossing points, Customs is also responsible for the maintenance of order.

At the Turkish border crossing points, the Turkish National Police were the single agency responsible for the control of travel documents. All the other functions are carried out by the Customs and certain specific authorities (like Human Health, Veterinary, Phytosanitary Services etc.).

The situation, prior to the twinning project, had some weaknesses in the field of information exchange between border organizations. Each organization is committed to achieving its mission according to their best knowledge, but poor cooperation reduces the effectiveness of the efforts of the organizations.

related to the border issues, if Turkey wants to be compliant with the EU requirements, they should modernize the regulations, the organizational structure of border policing and working methods in Turkey.

TR-07-IB-JH-04. Action plan on Integrated Border Management Phase 1. European Twinning Project

The EU twinning project formed a cornerstone of this development process for the Turkish border control system. The participant member states and the beneficiary country's project management worked in a joint manner in very close cooperation. The experts from both sides worked very effectively in order to prepare the project materials and achieve the expected results. Throughout the project implementation, the project management organized seven study visits (in the UK, the Netherlands, Spain, Sweden, Poland, and two in Hungary) where altogether 61 Turkish experts could gain experience on the spot about the best practices of the EU countries' border protection.

During the 18 month frame the project was rolled out, the Development and Implementation Bureau for Border Management Legislation and Administrative Capacity (IBM Bureau) and the Project Office organized 23 workshops, 2 seminars, and 9 roundtable discussions. Altogether 29 days were spent for training of the beneficiary's law enforcement staff. Within the frameworks of the training activities, the experts of the member states trained 150 experts on IBM from the beneficiary, some in the "train the trainer" manner, about know-how and the best practices of border policing from the Schengen Accord and the European Union. The IBM Phase-1 project management invited 47 experts to take part in the development work specified in the project's activities.

Figure 2. Sources of Experts

The project contract initially consisted of 30 activities, but during the implementation phase, the project management included three additional activities considering the specific development needs of the beneficiaries. The experts produced 33 activity reports and specified in detail the leaps forward. At the beginning of the project, the experts established an e-learning system in order to boost the development and training activities of the participants and also to demonstrate the project results for all partners and stakeholders. This IT system (available at www.bordman.net) provided non-stop accessibility for all registered users during the entire time frame of the project.

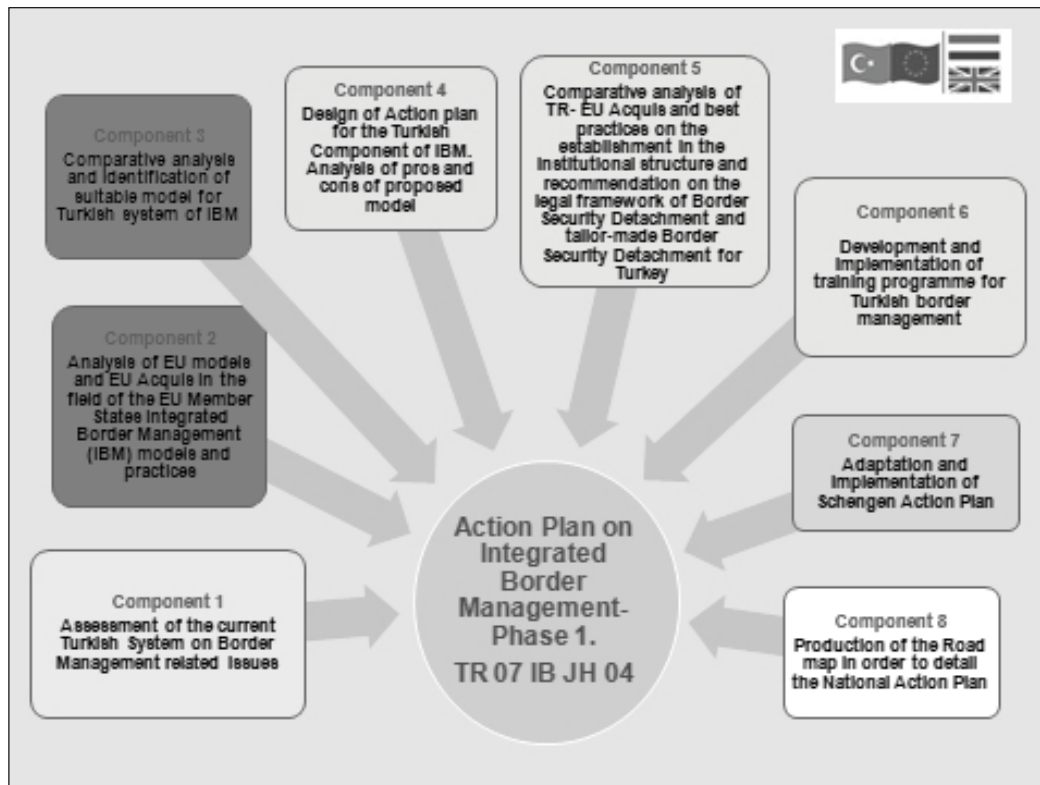
*Figure 3. Main Project Components*

The experts worked on setting up a basis for the establishment of a non-military, professional Border Guard organization according to the National Action Plan on the Implementation of Turkey's Integrated Border Management Strategy.

During the project implementation phase, all activity reports had to be submitted to the Turkish Project Management; these papers were negotiated and accepted as satisfactory.

The experts prepared all necessary and relevant materials, handouts, guidebooks etc. for the establishment of the Turkish IBM System and Turkish Border Guard. The Draft Border Guard Law and the future Border Guard Organizational Chart, the structure of Integrated Border Management were not accepted until now. Without these decisions the project results were dormant.

In spite of these complications, the project aims and the mandatory results were achieved; the project management handed all the relevant documents to the beneficiary organizations and the experts, who clearly benefited from these documents during the establishment efforts of the Turkish Border Guard organization and the Turkish Integrated Border Management System.

The main efforts for the modernization of the Turkish border policing system

AARMS (12) 1 (2013)

108

According to the Turkish National Action Plan of Integrated Border Management, the preparatory work started in 2008 and consequently, the Ministry of the Interior established an Integrated Border Management Office. Two fundamental missions were set for this unit. Firstly, they had to

carry out the coordination tasks in relation to the forming of the Turkish Border Guard Agency and secondly, to start the preparation work of the Integrated Border Management System.

Before the project was launched, the Turkish Prime Minister invited the potential participant ministries and state agencies, having relevance in border control, and asked if they support the transition to the concept of an integrated border management system and a future Border Guard organization. This survey indicates a very high-level coordination and support for the Twinning Project and also a clear commitment to cooperation for the mission's success. In addition the Prime

Kovács Gábor: The role of the Hungarian National Police in the transformation process of the Turkish Border... Minister established an IBM Coordination Board that had a session each quarter year and screened the developments of on-going and future assignments.

The Turkish Government realised soon that the new Border Guard organization and the new border control concept would add strong benefits to the effectiveness of Turkish border protection through their effective coordination and cooperation means and methods covering all traffic modes and border types (i.e. land, sea and air borders).

One of the core parts of the IBM Phase-1 Project is to assist in the education of the border staff. In the project 45 trainers were educated in the 'train the trainer' manner and an additional 150 staff members of various Turkish agencies have been trained in the new methodologies. These training course participants have been marked as the future staff of the new professional and civilian (i.e. not military) Border Guard organization selected to build up the IBM concept. Founding such an organization certainly takes time and coordination at each development step.

When the Turkish Border Guard has formed, the work will focus on one border section for a pilot project. For this role the Turkish-Bulgarian border was selected. After completing that, according to the roadmap, the new organization will take the responsibility over other border segments step by step. At this time, when the IBM structure is functioning properly, the Common Risk Analysis Centre is to be established, in order to allow the benefits of risk based policing to be added into it. In this structure all of the border agencies and relevant organizations will work together and provide the results of their joint efforts.

As a result of the common work of the EU experts and Turkish partners, a Draft Law on the Turkish Border Guard was drafted in December 2010 and submitted to the Turkish Ministry of the Interior in order to start the legislation process. In parallel to this work the experts worked on the preparation and implementation of the main elements of the project, like the adaptation of the Schengen Catalogue, the elaboration of a comprehensive training strategy, and the preparation tasks of the study visits (altogether six occasions).

The project concluded the proposed National Action Plan on IBM and updated the road map that describes the forthcoming assignments in great detail. The final summary report introduced the proposed Turkish integrated border management system.

The key developments of the project

Project management worked in very close cooperation with other projects such as the Nr. Tr080210, "Action Plan on Integrated Border Management-Phase 2". The aim of the 2nd phase of the IBM project was to enhance the solid risk management capacity of the border agencies and to strengthen further the integrated border management system in compliance with the best EU practices. Not surprisingly, this project had very close cooperation with the IBM Project Phase 1 that resulted in an intensive exchange of information between the managers.

The technical assistance tasks generated by the founding of the Turkish Border Guard organization was delegated to a separate project Nr: Europe Aid/127481/D/SEr/Tr, "Technical Assistance

for Development of the Border Management roadmap and Execution of a Border Gate Survey in Turkey" However, this technical assistance function was based very much on the results of the two IBM project phases.

Parallel with these projects the training functions were performed in a German-led project Nr.: Tr080213 "Training for Border Police". The aim of this project was to develop the training and education capacities for the future Border Guard Service.

The earlier mentioned projects were important cornerstones in the modernization process of the Turkish IBM. During the implementation of the projects, the Project resident twinning advisers shared information and supported the work of experts in order to achieve the common goals with the partners.

The beneficiary country organized several task force meetings to smooth the project implementation. During a 18 months period, there were three meetings of this forum. These meetings were ideal forums to talk with the Turkish project leaders and the IBM Coordination Board and also for the IBM Bureau, which could provide detailed information on the project developments.

Project developments

During the whole project implementation the experts of the member states and the beneficiary country worked in very close cooperation. All elaborated documents, results and presentations have been attached to the appropriate mission reports, and anybody who these papers might concern can benefit by accessing them through the e-learning system.

The experts of the member states made contributions to the preparation of the relevant draft Border Guard Act by considering the EU and Schengen regulations. The draft was further improved by the beneficiary's expert team in accordance with the Turkish requirements. We all considered it an important part of the assistance project that the EU and Schengen Acquis know-how and best practices, suggested by the twinning advisers be taken into account by the beneficiaries with the necessary "fine tailoring" according to the peculiarities of Turkey. Both parties agreed that it was not enough to hand over good solutions for providing excellent performance in border control from the EU member states, but the necessary attention had to be paid to localization as well.

The experts developed a comprehensive Training Programme for the participants of the Turkish border management system. This training program consisted of 14 linking IBM and border policing topics. During the preparation period the

project management consulted with the relevant institutions on the methodology and the training content. The training modules were supported with interpretation. The training materials became available from the first instance in the e-learning system on a bilingual basis. This methodology broke through the “language barriers” and allowed in the same time unlimited access to the training stuffs for the trainees.

During the implementation of the 6th component, for instance, the Turkish Project Management initiated an update of the Border Guard Training Strategy Paper that was welcomed by the project. So the “Training Strategy of Turkish Border Police” materials were elaborated with the sound consideration of the Schengen Catalogue, and an adaptation of the implementation plan was also compiled accordingly.

As part of the final activity, the experts carried out an overall evaluation of the project achievements. Within the framework of this particular desk-based study, they summarised the project accomplishments and besides, they elaborated a “Book of recommendations for the Turkish IBM”.

According to the detailed performance assessment the project implementation and the project team reached mandatory results, and the representatives of the beneficiary country received all the documents necessary to establish a new Border Guard Service and other IBM organizations.

Project visibility

During the length of the project implementation, the project leaders consumed most of the visibility costs; all required items are prepared according to the eU manual such as project logo, flyers, newsletters etc. During the study visits, these materials were shared with colleagues of 6 European countries.

The Kick-Off Meeting and the Final Conference received strong publicity from all stakeholder countries and very positive attention from high governmental representatives from both sides of the project.

The Hungarian “Police” magazine published articles about the milestones of the project achievements three times. The Turkish media attention was also significant. Various newspapers gave information about the project, in total 4 times.

Frequent update information was regularly provided to all registered users of the e-learning system, the project management informed all registered participants about the project results. The e-learning solution was proven very useful in the exchange of information with targeted groups of IBM.

The homepage of the Ministry of Interior published the most important information package about all the project activities. Within the duration of the project, 9 Project Newsletters were also issued and sent to all the project participants in electronic format and in hard copy to certain high-ranking participants. It means that the project management prepared a new newsletter issue every two months. The reactions to these activities were very positive.

Follow-up and sustainability

The beneficiary country enjoyed the advantages and the opportunities from the project results. Beneficiary institutions have gained comprehensive knowledge about integrated border management concepts and the experience on its implementation in the EU countries.

The work on preparing the Draft Law on New Border Guard Agency and Draft Road Map on Integrated Border Management already started while the project activities were still going on. The experts, who took part in the project, have consistently contributed to these projects. It is expected that these two documents will be finalized according to the needs of the Turkish border management system in the near future.

The beneficiary country’s administration has already started the implementation process. After the project closing event the draft road map will be prepared in the parallel project of “Tr0702.15-02/001 Technical Assistance for Development of the Border Management Roadmap and Execution of a Border Gate Survey in Turkey” by taking the twinning project results into consideration. After that, it needs to be endorsed by the competent authority. The implementation of the road map will lead to the establishment of the integrated border management system in Turkey.

The Border Guard Agency will act as the key agency that implements the concept of integrated border management. The draft law has to be submitted to the parliament for endorsement according to Turkey’s National Program for Adopting the EU
AA/MS/1 (2013)

All necessary measures have been taken in order to achieve the mandatory results. The required initiatives started a few years ago in setting the aim to establish an IBM system in Turkey. For that

purpose, a Strategy Paper on the Protection of The External Borders in Turkey was issued in 2003, the National Action Plan towards the Implementation of Turkey’s Integrated Border Management Strategy was endorsed by the Prime Minister in 2006, a National IBM Coordination Board was established in 2010, the Principles and Procedures on IBM Inter-agency Cooperation was adopted by the Board in 2011, the Draft Law on the Establishment of the Border Guard agency and the Draft IBM Road Map was prepared by the IBM Bureau within the Ministry of Interior.

The second phase of the Integrated Border Management project

The Finnish Border Guard claimed the right to implement the Tr 08 IB JH 04 Eu Twinning Project. The aim of this project is the establishment of the Common Risk Assessment Centre in Turkey according to the best practices of Schengen and Eu. This program started in January 2011.

This project forms the second phase and is based on the results of our project on the Action Plan on Integrated Border Management Project Phase-1. The exchange of information between these projects were complete, because of the e-learning system provided detailed project information available for each users.

The Training Project for Turkish Border Guards – TR 07 IB JH 02

Together with the creation of the Turkish IBM and Border Guard, another important project started the establishment of the training system for the future Border Guard staff. The leading country of this Twinning Project was Germany. This 15 month-long project started in December 2011.

Project participants were striving to avoid parallel results, so the three resident twinning advisers met and coordinated the process regularly in order to share the necessary information. The result of the joint work (coordination and common expertise) is the "Strategy Paper for Turkish Border Guards".

According to the ideas of the Turkish Minister of the Interior, the Turkish Police Academy set up the Border Guard Faculty in the academic years of 2010/2011. The first students finished their Border Policing studies in 2012. According to the long-term visions there is a plan to establish the independent Border Guard Academy, which ensures the new organization's border guard officer needs in the future. The establishment of the training institutions of the non-commission border guard officers is however still on the agenda.

Final recommendations

After the political decision, according to expert opinion there is still a need to appoint the leaders of the future Turkish Border Guard Agency and to continue the establishing process. In this aspect, a strong cooperation is vital between the Turkish IBM related authorities. According to the road map they will complete the transformation process within a 10 year frame.

Final recommendations:

1. Turkey should adopt a model of IBM that meets the Eu/Schengen requirements with a single border law enforcement agency (Border Guard), under the supervision of the Minister of the Interior. This agency has to act as the leading organization of IBM activities.
2. The IBM model for Turkey should be based on a single civilian (non-military) organization.
The short term experts recognised that due to the exceptional circumstances on the southern and eastern borders, Land Forces and Gendarmerie will be continuously required for surveillance duties during the full implementation of this model.
3. The establishment of coordination and cooperation bodies at all levels is essential to ensure effective inter-agency communication.
4. A new set of primary legislation related to IBM is required.
5. The changes, improvements and modifications to the Draft Border Guard Act, suggested by the short time experts, shall be adopted.
6. The Draft Laws on IBM and Border Guard must be finalised as soon as possible.
7. The exercise of replacement and amendment of other relevant legal documents is to be taken forward and reviewed regularly.
8. A four level organizational and managerial command system (central, regional, provincial and local) should be established.
9. For Border Guard management purposes 5 regional directorates supplemented with a 6th directorate for covering Istanbul should be established.
10. Regional Border Guard Directorates should be sub-divided into 2 or 3 Provincial Directorates.
11. The draft Border Guard law has to enable the General Director to establish local units other than the four types defined above.
12. A new Border Guard Academy with regional training centres (vocational schools) should be established at Directorate levels being responsible directly to the General Directorate of the Border Guard.
13. The organizational structure for the General Directorate, proposed by the short time experts, is to be adopted.
14. It is essential that the Coast Guard be included in the Border Guard structure, because of its key role in "blue border" surveillance.
15. The organization of the regional Directorates should mirror the General Directorate's structure subject to their particular needs.
16. Each regional Directorate (except Istanbul) should be divided into Provincial Directorates.
17. Consideration should be given to setting up anti-terrorism units in the Eastern and South-eastern regional Directorates.
18. A minimum ratio of 4 to 5 border guards per kilometre is to be used in establishing the surveillance staffing requirements at the land border.

Kovács Gábor: The role of the Hungarian National Police in the transformation process of the Turkish Border...

19. Plans for selection, recruitment, appointment, training and organizational tasks of Border Guard should be developed.
20. The training budget is to be granted for the anticipated training requirements over the next 10 years.
21. Each effort must be completed by considering the deadlines contained in the road map.

Summary

Turkey started an evolutionary process in order to develop their current border management system according to the new requirements and challenges. With the results of the above mentioned twin-ning projects (*see its List of Achievement of mandatory results - Annex 1.*), the Turkish partner will have an excellent opportunity in the next 10-15 years, to create an integrated border management system that increases the efficiency of their own border security efforts. In addition the new system will meet the most modern border control concepts, the Schengen standards and the expectations of the European Union. In these challenges many Hungarian law enforcement officers (experts) played important roles, achieving a enormous reputation for the Hungarian National Police.

Annex 1 – Achievements of mandatory results

1. Assessment of the current Turkish System on Border Management related issues completed.
 - 1.0 Production of a report identifying organizational responsibilities and strategy
 - 1.2 Legal background of existing border management in Turkey - Identification of primary and secondary legislative frameworks for IBM
2. Analysis of eU models and eU Acquis in the field of the eU Member States Integrated Border Management (IBM) models and practices carried out
 - 2.0 Analysis report on identified eU Member States Models and Acquis in relation to IBM Systems
3. Comparative analysis and identification of suitable model for Turkish system of IBM completed
 - 3.0 Draft of Possible Alternative models for IBM system in Turkey
4. Action plan for the Turkish Component of IBM designed. Analysis of “pros and cons” of the proposed model.
 - 4.0 Implementation Plan for Turkish IBM
 - 4.1 New organizational model in the field of Turkish IBM (1. Legal and Regulatory Framework, 2. Management and Organization, 3. Procedures, 4. Human resources and Training, 5. Communication and Exchange of Information, 6. Infrastructure and Equipment.)
 - 4.2 Developed alternative institutional and organizational models, with pros and cons, based on the best practices of the EU member states with the participation of the relevant institutions.
5. Comparative analysis completed on Tr-EU Acquis and best practices on the establishment in the institutional structure and recommendation on the legal framework of Border Security Detachment and tailor-made Border Security Detachment for Turkey
 - 5.0 Comparative analysis report on Turkish and EU Acquis best practice. Institutional structure recommendation of Border Security Detachment.
 - 5.1 recommendations on the legal framework of Border Security Detachment -
 - 5.2 recommendations for tailor made Border Security Detachment for Turkey -
 - 5.3 recommendation report on the Joint Risk Analysis Centre for Turkey
 - 5.4 Developed model training programs for prototype border, surveillance and control points
6. Development and implementation of training programme / Training of Turkish IBM staff and Proposed Border Security Detachment staff and others. Model training programmes for Turkish border management
 - 6.0 Set up of e-learning system for the project, with registered users. Model training programmes for border management
 - 6.2 At least 150 staff successfully participated in trainings
7. Schengen Catalogue adopted and implemented
 - 7.0 Main points of the implementation process of Schengen Catalogue defined. Requirements of the best practice of Schengen border policing in the field of Turkish IBM outlined.
 - 7.1 Increased level of compliance with the Schengen standards and best practices by project end
8. Production of the road map in order to detail the National Action Plan Produced
 - 8.0 Input to the road map in order to detail the National Action Plan.
 - 8.1 recommendations of IBM drafted

114

References

Act Nr. 2692 on The Activity of Coastguard, Ministry of Interior IBM unit Archives
Act Nr. 3497 on Guarding of Turkish Land Borders, Ministry of Interior IBM unit Archives

- Council Regulation (EC) No 2007/2004 of 26 October 2004 establishing a European Agency for the Management of Operational Cooperation at the External Borders of the Member States of the European Union.
http://europa.eu/agencies/community_agencies/frontex/index_hu.htm (05.01.2013.)
- CSABA, Zagon: Border traffic risk assessment. In. AARMS Vol. 11, No. 2 (2012) pp.273–285
- Guidelines for Integrated Border Management in EC External Cooperation, European Commission, Europe Aid, Brussels, November 2009. http://syb.icisleri.gov.tr/ortak_icerik/syb/Guidelines_for_IBM_in_EC_External_Cooperation_EN.pdf (05.01.2013)
- National Action Plan Towards the Implementation of Turkey's Integrated Border Management Strategy, Turkish Ministry of Interior IBM Unit Archives, Ankara, 2006
- Tr 04 IB JH 05 Common Manual of Checks at the EU External Borders, Turkish Ministry of Interior IBM Unit Archives, Ankara, 2007
- Tr 04 IB JH 05 Development of Training System for Border Police, Turkish Ministry of Interior IBM Unit Archives, Ankara, 2007
- Tr 07 IB JH 02 The Training Project for Turkish Border Guards; Turkish Ministry of Interior IBM Unit Archives, Ankara, 2011
- Tr 07 IB JH 04 Action Plan on Integrated Border Management Phase-1; Turkish Ministry of Interior IBM Unit Archives, Ankara, 2007
- Tr 08 IB JH 04 Action Plan on Integrated Border Management Phase-2 Risk Analysis Centre; Turkish Ministry of Interior IBM Unit Archives, Ankara, 2011

Clausewitz and the Gestalt of War

JOBÁGY Zoltán

War features unpredictability, incompleteness and instability. It is composed of a complex web of interconnected constituents in which friction poses a serious challenge. Clausewitz regarded war an integrated and holistic activity with having one gestalt as a functional unit. The term gestalt comes from German and stands for shape. It refers to the concept of wholeness with properties that cannot be summed up by their parts and do not equal a simple summation. Unpredictability helps us see war as a phenomenon that cannot be compounded from the actions of the constituent parts. War can be described with a certain precision, but this precision is not necessarily relevant to the parts. The gestalt of war accords with the observation that war does not always allow for logical, direct and traceable connections between causes and effects.

The aim of this article is to examine the problem of unpredictability, incompleteness and instability in war, and to detail the consequences that follow from these attributes. Simply put, the essence of causality can be described best by a series of deductive if/then statements that stand for linear connections in which a particular cause results in a particular effect. Clausewitz warned that in war “there is a gap between principles and actual events that cannot always be bridged by a succession of logical deductions.”¹ He also made clear that war is composed of a complex web of interconnected constituents in which friction poses a serious challenge. The consequence is circular causation in which causes and effects are connected via feedback loops. There is always a chance for escalation as tiny differences between causes can lead to completely different effects over time. This indicates the impossibility to predict future time paths in the form of desired effects.²

Jomini and the Scientific Narrative

Approaching war in terms of causality means that we regard it as an analytically solvable, hence scientific phenomenon that allows for prediction in the form of causal statements. However, according to Clausewitz war’s proverbial friction stands for disguised correlations rather than detectable causal relations. A causal focus bears the risk of disregarding the difference between correlation and causation.³ Addressing war in a causal way inadequately captures its dynamic nature. Jomini desperately tried to establish a scientific theory of war, a good one and a half centuries ago. He provided his readers with a meaningful set of standardised scientific methods. He developed four maxims for the fundamental principle of war, but failed to make that very principle explicit. He provided the reader with eight rules for selecting tactical positions, twelve orders of battle, thirteen points for fighting battles, five directions for an attack by main force, three rules for pursuit, eighteen points for the movements of armies, and nineteen rules for the use of the artillery.⁴

1 CLAUSEWITZ (1993) p. 125.

2 STACEY (1996); WESLEY (2002)

3 CHRISTENSEN–RAYNOR (2003)

4 KUHN (1962); JOMINI (1992)

Time has mostly parodied and ridiculed his attempt to provide a scientific categorisation of war. Unlike the appreciation and influence he possessed before World War I, contemporary readers often find his work to be narrow, simplistic, occasionally boring and overtly superficial. Analysing only a small number of selected variables has a limited potential that yields a restricted set of options. Putting those options through the filter of various analyses and evaluations further narrows our blinders and does not address important issues such as clarity, rigour and utility for real-world application. Thus by looking at Jomini we have the impression that employing analytic principles of scientific inquiry can at best address war fought on paper but not real war fought with blood and guts. Jomini’s rigid, dogmatic and prescriptive thinking has relevance only for the former and even then with a strong limitation.⁵

Forced scientific principles based on direct causality and deduction, analytical rationality and categorisation fail to address much of war’s frictional mechanism. Scientific principles might be helpful in describing war, but its dynamics cannot be analysed on strict scientific principles only. The scientific narrative used by Jomini has its roots in the failed geometrical and mathematical schools of European military thinking of the outgoing 18th century. Any approach of this kind bears the danger of taking the *art* out of warfare by inserting more *science* at the same time.⁶

Causal Focus of Science

In order to explain the recurring popularity of applying scientific principles to war it is important to take a close look at the way science normally develops. According to Kuhn, the early stages of any science, for which he used the term normal

science, display a vast array of descriptions and interpretations that largely disappear when one of the competing schools triumphs. Scientific inquiry is a causal process that works toward homogenisation and ends with the acceptance of a certain paradigm. It proceeds by improving paradigms in the form of an infinite and spiralling determining-matching-articulating cycle. First it determines significant facts of reality at hand, then it matches significant facts with theory, and in the last stage it articulates the theory based on significant facts. This process implies that paradigms are objects for further articulation and specifications should new conditions arise. They are built on a few problems at hand to be solved and their success depends largely on the ability to force those problems into a preformed and inflexible box. Paradigms do not call for new sorts of phenomena since those that do not fit into them are often ignored and normally left aside. The result of this causal approach is a drastically restricted and narrow focus, which is both the driving force behind any scientific inquiry and the enabler to predict factual information of intrinsic and substantial value.⁷

Paradigms indicate that scientific endeavour is highly cumulative in its result. The steady extension of its scope and the ever-increasing precision of the knowledge gained result in science not aiming at factual or theoretical novelties, and in the case of success it finds none. As time passes not all existing theories of a scientific field support a given paradigm. Paradigms do change and those changes are normally accompanied by many speculative, roughly articulated and ad-hoc modifications. Paradigms can tolerate crises and accommodate tensions to a certain degree, but due to their causal focus scientists normally try to avoid anomalies and conflicts with existing paradigms. Consequently, science proceeds through the change of paradigms, which explains why scientists do not see something as something else, they just simply see it. As a result of the causal

5 SHy (1986)

6 VEGO (2006)

7 KuHN (1962)

focus of paradigms science proceeds towards a narrowing and ever increasing subdivision of its field of inquiry. It is exactly this causal focus that separates scientific activities from artistic activities. Clausewitz indicated that scientific endeavour with all its paradigms, methods and standards seeking causality, does not have much relevance for war. Friction does not allow for a narrow focus aimed at exploiting causal relationships in war.⁸

The most striking character of science is its ever-increasing specialisation, which evolves through the prolonged utilization of the scientific method of inquiry. In terms of scope and concern, the successive stages point towards an increase in detail and refinement. This means that while science can grow in depth, it may not grow equally in breadth. Facts of scientific inquiry always reflect the crude facts of nature and translate these facts into another and more convenient language. The properties of the raw material on which the inquiry focuses always limit scientific freedom. This limitation, also in terms of causality, indicates that the border between rough and scientific facts can never be precisely drawn.⁹

Due to such imprecise borders, any given law of science is always approximate, probable, and incomplete. Although it can be replaced by other, closer and more probable laws *ad infinitum*, it will always be an approximation differing as little as chosen “from exactitude and the probability from certitude.”¹⁰ Laws and paradigms are useful tools for scientific inquiry, but they are by definition imperfect and provisional. The often praised objectivity of science is nothing more than a provisional, crumbling and crude image. It indicates that even natural science can never be true, only convenient.¹¹

Unpredictability as Gestalt

The causal focus of natural science does not indicate that paradigms can stay unchanged. They do change from time to time, which induces re-examination and re-education of the existing world view. This painful and controversial process is normally accompanied by the emergence of a novel *gestalt*. The term comes from German and stands for *shape* that refers to the concept of *wholeness*. A gestalt stands for a functional unit with properties that cannot be summed up by their parts. Thus a gestalt does not equal a simple summation.¹²

Clausewitz did not attempt to provide a scientific image of war and did not come up with any paradigm for a phenomenon that “appear[s] to defy a “scientific” approach.”¹³ Clausewitz regarded war an integrated and holistic activity with one common denominator, a functional unit that forms a recurrent pattern in his work. Unpredictability can be seen as Clausewitz’s *gestalt* for war. Unpredictability is manifest in friction and best expresses his message that war is an extended event that cannot be properly described as the exact sum of smaller and independent events. Unpredictability as gestalt displays war as a human phenomenon, which poses problems often falling outside the reach of scientific inquiry, paradigms and causal explanations. Unpredictability helps us see war as a functional whole that cannot be compounded from the action of its constituent parts. Unpredictability can be described with a certain precision, but this precision is not necessarily relevant to the parts as war does not allow for logical, direct and traceable connections between causes and

8 KuHN (1962); CLAUSEWITZ (1993)

9 KuHN (1962); POINCARÉ (1982)

10 POINCARÉ (1982) p. 341.

11 POINCARÉ (1982)

12 KuHN (1962); GOVE (1981)

effects. unpredictability comes as a result of mutually determined parts of an interactive process that cannot be adequately described by the sum of causal relationships. It indicates that causes and effects are often the result of hidden, intrinsic interactions.¹⁴

unpredictability comes as the result of terror, disequilibrium, and non-linearity created by two opposing groups of intelligent human beings. Scientific paradigms stand for firm and reliable information regarding some basic assumptions in terms of causality. Unpredictability in contrast reflects that war always depends on a wide variety of factors that can either be known, unknown but knowable, or unknown and unknowable. unpredictability is responsible for the gap between information known and information desired to be known, which in the case of science can normally be filled by scientific inquiry and endeavour.¹⁵

Science and its supporting paradigms always assume that there are clear and definite answers to clear and definite questions. The driving force is a causal assumption that information known and information to be known can eventually overlap. In war there is no such overlap as the only certainty is that war waged differs from the war expected to wage. Clausewitz pointed out that war often seems to be the difference between plans and events, fiction and reality. The most striking difference between war and science is that the research of the former can mostly be defined by a lack of any significant progress. This explains why it is still possible to refer to a theorist who lived nearly two centuries ago. Many theories of war display various mutually inconsistent propositions and findings that exist side-by-side and do not allow for the establishment of any sort of scientific paradigm. This anomaly is mostly of a systemic nature, and is manifest in the impossibility of applying the methods of scientific inquiry to war. War is a context-dependent cultural and social system consisting of a network of components that often act in parallel. The result is that everything moves, as nothing is stationary.¹⁶

Sources of Unpredictability

unpredictability as proposed *gestalt* of war might be bewildering at first. During most of our life we are socialised to see the known, and are rarely prepared to learn about the unknown. Consequently, the known is pressed on our mind from the outset and the unknown is regarded mostly as irrelevant. We conveniently move along a narrow path of knowledge and think that more is known than actually is. As time passes we are confident that many unknown things usually become known. However, the unpredictability of war indicates that beyond the contours of the unknown there is a vast array of inherently unknowable phenomena. Science reflects the natural world by focusing on the known and the unknown, but mostly leaves the unknowable out of its scope. It is a correct, but artificial reflection of the natural world in which paradigms provide convenient tools that are always simpler and more controllable than the natural and original. Given that war is waged by complex and idiosyncratic humans, any attempt to separate the known, the unknown and the unknowable is thus impossible.¹⁷

unpredictability stands for various possibilities in war. Clausewitz emphasised the impossibility of making predictions on the outcome in terms of causal statements. It is not surprising that for critiques *On War* is a theoretical mess, since it offers many and often contradicting views regarding the mech-

14 ASCH (1972)

15 GOVE (1981); MANSFIELD (1982); MCCrABB (2002)

16 FRIEDMAN (2003); GEErAETS (1998)

17 GOMORY (1995)

anism of war. Although Clausewitz's reasoning was limited by the state of science and its vocabulary of his age, as a compelling classic of Western military thinking, he was among the first who explicitly addressed war's complex and non-linear character. He emphasised that the conduct of war is not an analytical process, but one that always changes in an unpredictable way. Confronted with the unknowable and having no better toolset than the scientific vocabulary of the early 19th century explains why he introduced the idea of friction, which is an essentially mechanical, hence a scientific term.¹⁸

Clausewitz perceived war as a phenomenon involving a large number of interactive and competing factors that display a messy interplay between order and disorder, predictability and unpredictability. For him, waging war was a non-linear and dynamic process in which the inherent complexities and probabilities could not be seen as isolated phenomena. Beyerchen identified three sources of unpredictability such as interaction, friction, and chance. unpredictability from interaction emphasises war as an interactive process between intelligent and adaptable human beings. Actions in war do not produce simple reactions, but dynamic interactions, and any attempt to anticipate the enemy's move runs into considerable difficulty. Interactions allow only for vague assumptions in the form of generalisations based on qualitative theorising. War is a structurally unstable phenomenon, which means that participants must always expect disproportional effects and unpredictable situations. Friction as the second source of unpredictability has already been detailed. It is the sort of resistance that stands for the feedback effects responsible for constant novelty, and the fact that things in war never go as planned. Friction is the noise in the system of war and expresses how information distortion and overload can produce uncertainty regarding the actual state of affairs. Both resistance and noise emphasise that it is not possible to calculate in

advance what cause results in what effect. It is equally impossible to predict which effect will turn out to be critical and decisive. unpredictability based on chance means that most of the factors on which actions are based are obscured and distorted in war. Chance has three sources from which it stems, such as statistically random phenomena, amplification of micro-causes, and the result of analytical blinders. All refer to the role of probability in calculations due to the enormous amount of variables. The result is that small causes can generate disproportionate effects and there will always be the possibility that the result of any given action can defy the odds. The precision of available information regarding causes and their effects is always limited and attempts to reconstruct causal relationships will always face the lack of precise and accurate information.¹⁹

Clausewitz emphasised that human intuition is guided by linear conceptions, which are of analytical convenience rather than real-world relevance. unpredictability as *gestalt* indicates that attempts to generate principles for the conduct of war and discern clear causality is a desirable, but an unattainable goal.²⁰

Chaotic Nature of War

War is a phenomenon composed of a multitude of connected parts and according to Clausewitz every act in war has consequences, which could be either intended and immediately obvious, or unintended and delayed. Although he knew that war displays cause-and-effect relationships, he equally argued that war's frictional mechanism renders it largely impossible for most attempts to take full advantage of direct causality.²¹

18 BEYERCHEN (2005); FLEMING (2004)

19 BEYERCHEN (2005)

20 BEYERCHEN (2005)

21 BEYERCHEN (2005)

Whereas he invented friction to describe war's unpredictability, we can refer to the recent concept of chaos that offers a more detailed insight into the mechanism of war. Strictly speaking chaos is a mathematical concept that does not mean anarchy or confusion. It describes disorder that arises from non-random causes. Chaos is used to describe a range of irregular behaviours in which seemingly random occurrences can be depicted by entirely deterministic and often very simple equations. Chaos occurs in nearly all aspects of military affairs and stems from the presence of feedback. The behaviour of a chaotic system is non-periodic and apparently random, which means that the system's response is recurrent, but no longer predictable. The inability to make long-term predictions in chaotic systems is not due to the lack of data, but an immediate consequence of the non-linear rules that govern its behaviour. Deterministic chaos can best be described as irregular or random appearances of nonlinear dynamic systems, in which dynamic laws determine the time evolution of the system based on its history. The necessary ingredients for a system to be labelled as chaotic are, among others, non-linearity, non-periodicity, sensitivity to initial conditions, and mixing. Chaos' biggest implication for war is that in non-linear systems we must always expect instability in the form of novelty.²²

Clausewitz suggested that war is chaotic and there is no way to predict the effect of the actions of the participants with any great certainty. Historical evidence indicates that predictability and control are already lost at the threshold separating war and peace. In a chaotic system small perturbations of initial conditions can lead to unforeseen changes. War's unpredictability is as much manifest in creating structures, as it is in tearing them apart. The creation and dissolution of order go hand in glove and defy most explanations based on deductive causal models, which is an important characteristic of scientific research.²³

Although chaos is a deterministic mathematical concept that does not mean randomness, in English parlance it is understood heuristically, and synonymous with chasm, gulf or abyss. Chaos includes chance, which is subject to no law and displays no signs of uniformity. It is not a distinct or an orderly form, but precedes the creation of order. In war military operations often display a state of confusion including complete disorder, lack of sequence, organization, and any sign of predictability. Chaos in war seems to be for many "a confused mass or agglomerate of matters or heterogeneous items that are hard to distinguish, isolate or interpret."²⁴

War, Chaos and Determinism

Scientific inquiry can best be characterised by attributes such as covering laws, known initial conditions, deduction, prediction and explanations. The result is deductive-nomological models capable of connecting causes and their effects each occurring as contiguous instants at their own place and time. Mathematically chaotic systems are deterministic and governed by laws that indicate intimacy between causes and their effects, since only their sensitivity to initial conditions qualifies them as chaotic. In war, attempts to connect causes and effects run against war's frictional mechanism lacking such intimacy. Despite similarities in terms of chaos, war probably cannot be regarded as a chaotic system in strictly mathematical terms. Although it displays particular factors and events coalescing in various proportions to realise their end, war is far more complex than any sophisticated mathematical model.²⁵

22 JAMES (1996); DURHAM (1997); ILACHINSKI (1996a)

23 BEYERCHEN (2005); SAPESTEIN (1984); SAPESTEIN (1995); KURUC (2003)

24 GOVE (1981) p. 375.

All these factors together with the human tendency to gauge decisions by relatively external events indicate the impossibility of comprehending all variables in war. The result is that war cannot be regarded as a closed and isolated phenomenon. The greater the temporal and spatial difference between initial conditions, the bigger the inaccuracy with which those conditions can become known. Temporal and spatial factors always diminish the accuracy of any deductive and nomological explanation, which can only cover events and their immediate consequences. War displays tangled and intricate relationships and as various temporal and spatial limitations indicate, causal relationships in war are never fully contiguous or fully point-like.²⁶

Any attempt to detect causality must contend with an emergent novelty. Unpredictability as *gestalt* of war does not allow for any separation into parts to be studied individually, but is composed of so many components and elements that identifying causal subordinations to newly emerging processes can be very difficult, if not impossible. Although certain aspects of emergent properties might allow for detecting causal relationships, other aspects possess characteristics of their own that cannot be determined in terms of causality. Thus in the case of analytical rationality and categorisation we face a general methodological problem. Attempts to identify the components of a given system and the dimensions according to which they are arranged can only be done incompletely. Open and dynamic systems evolve over time. Any identification process can be considered adequate only, if we are able to enumerate all the unfilled positions and the strains they create. This however, is again supplanted to a novelty we cannot anticipate as such systems do not exhibit mathematically representable temporal series of behaviour. Consequently, the system is unquantifiable in terms of causal relationships and does not permit accurate prediction regarding its future states.²⁷

War as Natural Form

The issue of determinism/indeterminism in war is closely related to human free will. An irregularity understood heuristically is not generally incompatible with determinism, except when it has no determining conditions for its occurrences.²⁸

We often might not precisely know the conditions for the occurrence of many chaotic events, but are basically confident regarding those conditions. This confidence explains why it is possible to establish relationships between statistical properties of events, and why we are less successful in doing the same for individual events and their properties. Applying various statistical variables expresses our ability to consider the statistical properties of the elements accompanying the events. The question of whether events occur in an absolutely heuristic or deterministic fashion is not an issue that has significant importance as real life is compatible with both. Thus the question of whether structures are heuristic or deterministic in war is basically nothing more than a subject of inconclusive controversy, since both indicate unpredictability. Heuristic and deterministic structures refer to *natural forms* that stand for occurrences and phenomena we can perceive. They are isomorphic structures across the fields of human inquiry such as biological cells, economic societies, the population of organisms, and in our case – war. Natural forms can be understood either as a *natural complex* or a *natural system*. Although both refer to the same, they possess different attributes. Whereas a natural complex displays purposeful forms and organic interactions among the constituents, a natural system displays chaotic forms and topographic interactions among the components.²⁹

26 POOL (1989)

27 EMERY (1974)

28 LORENZ (1993)

Thus any given natural form can be examined either as a natural complex or as a natural system. Although both constructs stand for unpredictability, the difference comes from subjective interest. Natural complex is a form composed of constituents, which are non-separable from each other. Every attempt to divide or dissect a natural complex obviously changes its identity. Due to the organised division of labour within such a complex, one constituent's particular function complements the function of the other constituents organically. The unpredictability of a natural complex arises from non-determinism, as it reacts differently to the same stimulus. Natural system is composed of constituents that are separate, but not independent from each other, which indicates that the components act as external and arbitrary impetuses. They are separate, but have a *chain-like integrity* that cannot be divided. Consequently, unpredictability of a natural system is the result of human ignorance regarding all the factors at play and we face determinism in which topographic interactions involve efficient causation.³⁰

War as a natural form can be regarded both as a heuristic and deterministic phenomenon in which the difference does not come as a result of the underlying attributes, but as of respective inquiry. War as a natural form indicates similarities with systems, such as the weather or a rain forest, which might be heuristic real-world phenomena, but can nevertheless be modelled and explained to a given degree by deterministically chaotic mathematical models.

Incompleteness and Instability

Due to the presence of chaos in war, the history of warfare is replete with examples in which dramatic consequences resulted from minor actions, or that identical actions have resulted in different outcomes. War as a distinct and specific form of social interaction does not always display a direct relationship between causes and effects. The obvious similarity between a chaotic

abstract mathematical model and a chaotic social and cultural phenomenon such as war allows for an extended examination of unpredictability. Chaotic structures are vulnerable to dissolution, and the higher the number of actors and longer the time-scale of prediction, the greater the problem of accuracy. regardless of whether chaos is seen as a deterministic or heuristic phenomenon, it indicates that in war the general push for stability is nothing more than illusion.³¹

War is full of dispersed, diffuse, intermittent and irregular processes that stand for fluid and dysphasic movements constantly eroding attempts to achieve symmetry and order. Consequently, war stands for a constant interplay between fractalisation and the drive for homogeneity.³²

War as a natural form also reminds us that any outcome reflects the complex interactions of the constituents in which unpredictability is at best the “combined effect of friction, disruption, and lethality of unit behaviour”.³³

regardless of how we name the aggregate results, war does not provide for consistency and completeness either. Whereas consistency refers to the lack of contradictions, completeness expresses the ability to provide for proofs of all true statements. Even if war provided for such attributes and could be described entirely in mathematical formulas, Gödel proved that it is not possible to reach consistency and completeness. According to him all formal mathematical systems, despite the fact that they display completeness and consistency, are inherently incomplete. They might be true, but cannot be proved despite the abundance of existing axioms and rules of inference. Gödel

30 KHALIL (1990); BUCHLER (1966)

31 MANN (1992); PEATLAND (1993)

32 SAPErSTEIN (1995); BEAuMONT (1994); NICHOLLS–TAGArEV (1994); WEEKS (2003)

33 CrAMEr (1993); PFAFF (2000); HErMAN (1999) p. 87.

understood formalisation as achieving consistency and completeness, in which axioms and rules are tools applicable to all mathematical questions in expressible formulas. However, he concluded that consistency and completeness can never be reached even in formal mathematical systems, as there would always be simple problems that cannot be decided from axioms. Since problems of this kind appear in a very extensive class of formally expressible systems, he concluded that every formal system must contain propositions that cannot be decided. In other words, there would always be propositions that cannot be proved or disproved. Gödel’s theorem indicates that there are always propositions that assert their own improbability. Consequently, even formal systems in which the class of axioms and rules of inference can be recursively defined display undecidable propositions. Similar to a complex social phenomenon such as war even formal mathematical systems are incomplete and display logical inconsistency.³⁴

Structural Variance and Non-Monotonicity

Gödel’s incompleteness theorem also explains why computer-based simulations of war are essentially unstable and display inconsistency between input and output. Computer simulations are excellent examples that even if there are definable deterministic relationships within a given system that can be formalised mathematically, we must always expect occurrences that cannot be proved or disproved in terms of causality.³⁵

Despite attempts to comprehend war in terms of causality we always face inconsistency and incompleteness. Even simpler settings that attempt to model it show non-linear attributes and signs of instability. The Lanchester equations were the first combat model that attempted to estimate war mathematically in terms of casualty rates. Lanchester wanted to catch the essence of loss ratios in combat based on a pair of coupled differentials. From a contemporary point of view the equations seem very crude and clumsy tools. Growing computing power in the second half of the 20th century has enabled analysts to model increasingly more aspects of war’s complex features. However, the result of this development was that the relatively simple model instability of the Lanchester equation has been replaced by other instability yielding more divergent and unexpected results.³⁶

The term *structural variance* was the first attempt to express the occasional and seemingly erratic behaviour that came from a strictly deterministic mechanism of the models employed. Another attempt to describe model outputs, which were seen as irregular functions of the input parameters, resulted in the term *non-monotonicity*. Both describe erratic outputs that were regarded mostly as the analysts’ faults. Although first efforts were aimed at finding reduction techniques for these anomalies, later it was found that in the case of complex simulations, even infinitely small factors such as computer rounding errors, can become the source of instability. It was concluded that dynamic instability appears to be an inherent feature of complex simulations. This conclusion however, allows for a much broader generalisation. If deterministic combat models, based on highly controlled conditions can display irregular outputs, then real wars in which the signs of determinism are less clear may be destined to do so. real war is always more complex than any model can ever become. Therefore if relatively simple computer models can show signs of instability then “the instability of the corresponding reality is certainly implied.” This however, allows only for a very low practical ceiling for applying scientific principles for war.³⁷

34 GöDEL (1962); COVENEy–HIGHFIELD (1995)

35 GOVE (1981)

36 SIDrAN (2004); SPEIGHT (2002), GLENN (1996)

Conclusion

Clausewitz wanted to “iron out a good many kinks in the minds of strategists and statesmen [and] to show what the whole thing is about and what the real problems are that have to be taken into account in actual warfare.”³⁸ In a similar, but more limited fashion it was our intention to examine certain aspects of war and display it as a phenomenon that allows for causal explanations only with clear limitations.

unpredictability as *gestalt* indicates that any sober theory must take into account that waging war is an act that has always been more than linking ends with means. A scientific approach to war represents deductive reductionism and causal laws attempting to predict certain effects. The supporting assumption is that war displays order and equilibrium, the possibility for rational choice, and the ability to steer and control events. War however, contains variety and novelty in which certain properties remain unknowable to the human mind. War can be described in general terms using causal relationships, but effects that go beyond the immediate spatial and temporal levels cannot be predicted with any accuracy. In war everything is interrelated and all we can attain is nothing more than a temporary and partial interpretation.

unpredictability as *gestalt* reminds us that instead of focusing on certain desired effects, we should embrace its friction and respond consistently to its unpredictable occurrences. War cannot be waged based on single and prescriptive models, but requires that we evolve rapidly in order to handle dynamic and changing situations. Thus we must be satisfied with understanding certain general features in terms of correlation, rather than attempting to discover a mechanism that links causes with effects directly. War is full of emerging opportunities that can only help explain qualitative behaviour, but never accurately predict futures in terms of effects.

unpredictability as *gestalt* reflects that scientific principles such as deduction, analytical rationality and systemic thinking have limitations for war. War might display direct causality, but assumptions that rest on equilibrium and a constant environment make up only a small fraction of its bewildering nature. However, at first glance a scientific approach might appear to be weighty both in scope and insight as it draws on a diverse array to generate hypotheses about war. This eclecticism is admirable, but often indicates inconsistency and a vocabulary that has no sound foundation. Even deductive thinking and analytical rationality do not make it possible to distinguish sufficiently among various alternatives nor can satisfyingly explain the preference for certain selected factors.

unpredictability as *gestalt* warns us that blind adherence to predefined objectives can result in mounting costs both in terms of money and men. Accepting surprise, making moves, observing the results and continuing with the ones that seem to work are inherent features of war. Any conceptualisation of war can be scarcely more than an attempt to grasp a continuously shifting process. War happens on a continuum and it is understandable that focusing only on certain factors is necessary for analytical reasons. However, narrow conceptualisations that do not provide for compelling explanations and instead of examining variations in terms of their appearance, emphasize only apparent similarities. This appears to be plausible at first glance, but a closer examination reveals it to be problematic. It obscures truly intriguing differences that might theoretically belie the notion that wars and military operations should be analysed as a uniform class.

unpredictability as *gestalt* highlights that although it is always helpful to discern certain universals that can guide our actions, turning those universals into fixed laws and values with the hope to detect causal relationships, is mostly impossible. War is a context-dependent human phe-

38 CLAUSEWITZ (1993) p. 78.

phenomenon that does not provide for blueprints to act on. It moves back and forth from stability to chaos that occurs simultaneously across its various levels. Consequently, success in war demands the ability to learn from actual experience, rather than the ability to formulate action based on past experience. Waging war is as much a science as an art and that must be taken into account in every conceptualisation.

The completion of this study was done within the framework of TÁMOP-4.2.1.B-11/2/KMR-2011-0001 “Critical Infrastructure Defence Research” program: “Civilian-Military Partnership” sub-program: “Development of Human Defence, Peace Operation and Crisis Management Processes” major research area.

References

- ASCH, Solomon E. (1972): *Gestalt Theory*. In SILLS, David I. (ed.): *International Encyclopedia of the Social Sciences*, Volume 16, New York Macmillan & The Free Press, pp. 158-174
- BEAUMONT, Roger (1994): *War, Chaos, and History*, Praeger Publishers.
- BEYERCHEN, Alan D.: *Clausewitz, Nonlinearity and the Unpredictability of War*. www.clausewitz.com/CWZHOME/Beyerchen/CWZandNonlinearity.htm (02.08.2005.)
- BUCHLER, Justus (1966): *Metaphysics of Natural Complexes*, Columbia University Press.
- CHRISTENSEN, Clayton M. – RAYNOR, Michael E. (2003): *Why Hard-Nosed Executives Should Care*

- About Management Theory*, Harvard Business Review, September 2003, pp. 67-74
- CLAUSEWITZ, Carl von (1993): *On War*, Everyman's Library.
- COVENEY, Peter – HIGHFIELD, Roger (1995): *Frontiers of Complexity, The Search for Order in a Chaotic World*, Faber and Faber.
- CRAMER, Friedrich (1993): *Chaos and Order, The Complex Structure of Living Systems*, VCH Verlagsgesellschaft.
- DURHAM, Susan E. (Maj.) (1997): *Chaos Theory for the Practical Military Mind*, Air Command and Staff College, March 1997
- EMERY, Frederick E. (1974): *Methodological Premises of Social Forecasting*, in: Annals of the American Academy of Political and Social Science, Volume 412, The Information Revolution, March 1974, pp. 97-115 <https://doi.org/10.1177/000271627441200110>
- FLEMING, Bruce (2004): *Can Reading Clausewitz Save Us from Future Mistakes?* Parameters, Spring 2004, p. 62-76
- FRIEDMAN, George (2003): *The Unpredictability of War and Force Structure*, The STRATFOR Weekly, 29 September 2003. www.vialardi.org/IRAQ/unpredictability_of_war.html (12.08.2005)
- GEEAERTS, Gustaaf (1998): *Non-Linearity, Chaos and the Predictability of War*, Pole Paper, Volume 4, Number 1, January 1998. www.poli.vub.ac.be/publi/pole-papers/pole0401.htm (02.08.2005.)
- GÖDEL, Kurt (1962): *On Formally Undecidable Propositions of Principia Mathematica and Related Systems*, Basic Books.
- GOMORY, Ralph E. (1995): *The Known, the Unknown and the Unknowable*, essay, Scientific American, June 1995, p. 88. <https://doi.org/10.1038/scientificamerican0695-120>
- GOVE, Philip B. (ed. i. ch.) (1981): *Webster's Third New International Dictionary of the English Language*, unabridged, Merriam-Webster Inc.
- HERMAN, Mark (1998): *Entropy-Based Warfare: Modelling the Revolution in Military Affairs*, Joint Forces Quarterly, Autumn/Winter 1998-99, pp. 85-90.
- ILACHINSKI, Andrew (1996a): *Land Warfare and Complexity, Part I: Mathematical Background and Technical Sourcebook*, Center for Naval Analyses, CIM 461, July 1996.
- ILACHINSKI, Andrew (1996b): *Land Warfare and Complexity, Part II: An Assessment of the Applicability of Nonlinear Dynamics and Complex Systems Theory to the Study of Land Warfare (U)*, Center for Naval Analyses, CRM 96-68, July 1996.
- JAMES, Glenn E. (1996): *Chaos Theory, The Essentials for Military Applications*, The Newport Papers, Naval War College, October 1996
- JOMINI, Baron Antoine Henri de (1992): *The Art of War*, Greenhill Books, London, Stackpole Books, Pennsylvania, 1992
- KHALIL, Elias L. (1990): *Natural Complex vs. Natural System*, Journal of Social and Biological Structures, Volume 13, Number 1, 1990, pp. 11-31 [https://doi.org/10.1016/0140-1750\(90\)90031-Z](https://doi.org/10.1016/0140-1750(90)90031-Z)
- KLINGER, Janeen (2006): *The Social Science of Carl von Clausewitz*, Parameters, Spring 2006, pp. 79-89
- KUHN, Thomas S. (1962): *The Structure of Scientific Revolutions*, International Encyclopaedias of Unified Science, Foundations of the Unity of Science, Volume 2, Number 2, 1962
- KURUC, Anton (2003): *The Relevance of Chaos Theory to Operations*, Australian Defence Force Journal, Number 162, September/October 2003, pp. 4-16
- LORENZ, Edward N. (1993): *The Essence of Chaos*, WCL Press.
- MANN, Steven R. (1992): *Chaos Theory and Strategic Thought*, Parameters, Autumn 1992, pp. 54-68
- MANSFIELD, Sue (1982): *The Gestalts of War, An Inquiry into Its Origins and Meanings as a Social Institution*, The Dial Press.
- MCCRABB, Maris Dr.: *Uncertainty, Expeditionary Air Force and Effects-Based Operations*, Air Force Research Laboratory, 2002b, pp. 7-8. www.eps.gov/EPSdata/uSAF/Synopses/1142/reference-number-PRDA-00-06-IKFPA/uncertaintyandoperationalart.doc (23.04.2003)
- NAGEL, Ernest (1979): *The Structure of Science, Problems in the Logic of Scientific Explanation*, Hackett Publishing Company.
- NICHOLLS, David (Maj.) – TAGAREV, Todor (Maj.) (1994): *What Does Chaos Theory Mean for Warfare?*, Aerospace Power Journal, Fall 1994, www.airpower.maxwell.af.mil/airchronicles/apj/apj94/nichols.html (10.12.2003.)
- PEATLAND, Pat A. (Lt. Col.) (1993): *Centre of Gravity Analysis and Chaos Theory*, Air War College, Air University, April 1993.
- PFAFF, Charles A. (Maj.) (2000): *Chaos, Complexity and the Battlefield*, Military Review, July August 2000, pp. 83-86.
- POINCARÉ, Henry (1913): *The Foundations of Science, Science and Hypothesis, The Value of Science, Science and Method*. The Science Press, New York and Garrison. 127
- POOL, Robert (1989): *Chaos Theory: How Big an Advance?* Science, 7 July 1989, pp. 26-28
- REISCH, George A. (1991): *Chaos, History and Narrative*, History and Theory, Winter 1991, pp. 1-20
- SALMON, Wesley C. (2002): *Causation*. In: GALE, Richard: *Blackwell Guide to Metaphysics*, Blackwell., 303-305
- SAPERSTEIN, Alvin M. (1984): *Chaos – a model for the outbreak of war*, Nature, 24 May 1984, pp. 303-305
- SAPERSTEIN, Alvin M. (1991): *The "Long Peace" – Result of a Bipolar Competitive World*, Journal of Conflict Resolution, Volume 35, Number 1, March 1991, pp. 68-79
- SAPERSTEIN, Alvin M. (1995): *War and Chaos*, American Scientist, November-December 1995, pp. 548-557
- SHY, John (1986): Jomini. In PARET, Peter (ed.): *Makers of Modern Strategy: From Machiavelli to the Nuclear Age*. Princeton: Princeton University Press, 1986, pp. 164-184 <https://doi.org/10.2307/j.ctv8xnhvw>
- SIDRAN, Ezra D. (2004): *A Calculated Strategy: Readings directed towards the creation of a strategic artificial intelligence*, readings for research, Spring 2004, pp. 11-13, www.cs.uiowa.edu/~dsidran/

- readingsForresearch2.pdf (10.11.2005.)
- SPEIGHT L. R. (2002): *Lanchester's Equation And The Structure of the Operational Campaign: Between-Campaign Effects*, Military Operations research, Volume 7, Number 2, 2002, pp. 15-33
- SPEIGHT, L. R. (2003): 'Structural Variance' or 'Non-Monotonicity' Effects in Combat Models: A Review, Military Operations research, Volume 8, Number 1, 2003, pp. 17-33
- STACEY, Ralph D. (1996): *Strategic Management & Organisational Dynamics*, Pitman Publishing. VEGO, Milan N.
- (2006): *Effects-Based Operations: A Critique*, Joint Force Quarterly, Issue 41, 2nd Quarter 2006, pp. 51-57
- WEEKS, Michael R. (Maj.) (2003): Chaos, Complexity and Conflict, Air & Space Power Chronicles. www.airpower.maxwell.af.mil/airchronicles/cc/Weeks.html (22.05.2003.)

Horn of Africa. The Major Factors in Regional (In)security

BÁLINT Tamás – ZSIFKÓ Mariann¹

Despite its strategic location, the area known as the Horn of Africa has become one of the most badly impacted areas of the African continent through its political and economic crises and humanitarian disasters. Since Siad Barre's fall, Somalia is an area of continuous civil war. The neighbouring countries – led by their own interests – directly and indirectly interfere in the internal affairs of Somalia. As part of this intervention, they have repeatedly attacked the terrorist organization called Al-Shabab. Because of pressure and support from the international community, the transitional government initiated numerous reforms, and by 2012 at the end of the transitional period a new Federal Constitution was adopted, the new Parliament was established with the election of the country's new President. However the new government still has to face tribal rivalry, extreme Islamist movements to stabilize its power.

During the Cold War period, peoples of Eastern Africa proclaimed and created their independent states within the boundaries drawn by the former colonialist powers. The security and economic situation of the freshly established Eastern African states depended largely on the support of the two super powers. In 1991, the uSA and the Soviet union both withdrew their support from the Somali government led by Siad Barre, thus prompting its fall, causing total chaos and the disruption of the political superstructure and unleashing a series of armed conflicts among the states in question.

In 1991, Somalia's north-western territory proclaimed its independence as the republic of Somaliland, while the north-eastern Puntland became an autonomous territory inside the state. A number of clans and extremist Islamist groups fought in the southern and south-eastern part of the country over the control of the area. In 2002, the Somali factions – except for Somaliland – signed a ceasefire agreement in Eldoret, Kenya, which served as a basis for the Federal Constitution and for forming a Transitional Federal Government (TFG) and a Transitional Federal Assembly (TFA), in 2004. In 2006-2007, the so-called Supreme Council of Islamic Courts (SCIC)² launched an attack against the TFG and its supporters and took control of the southern part of the country. The TFG asked for Ethiopian military assistance and together they managed to wear down the SCIC military force by the end of 2006, causing the organisation to dissolve³. The driving out of the Islamist extremists, however, resulted in increasing maritime piracy sanctioned by Sharia law⁴. It rendered the government's battle against the extremists more difficult as the government forces

1 Email: zsmariann1@yahoo.com

2 Formerly it had existed under the name of the union of Islamic Courts (uIC), which took control of Mogadishu in 2006. The uIC had consisted of 11 independent religious councils and had maintained tight relations with Al-Qaeda terrorist organisation.

3 It fell apart to the Alliance for the re-Liberation of Somalia, Djibouti and Asmara and the Shabab Militia (ras Kamboni Brigade of Shabab).

4 According to the report issued by the Maritime Bureau's Piracy reporting Centre, 111 out of the 298 anti-ship attacks took place in 2008.

were also composed of several clans, frequently clashing with each other⁵.

In 2008, the Djibouti wing of the anti-government *Alliance for the Re-liberation of Somalia* (ArS) signed a peace agreement with the TGF and took part even in the presidential elections of 2009. ArS-D⁶ leader Sheik Sharif Sheikh Ahmed won the presidential elections.

In 2008, Ethiopian troops withdrew from Somalia leading to a power vacuum in the country. The radical Islamist militias and clans immediately took advantage of the situation and attacked the joint TFG and AMISOM subunits⁷. In 2009, Al-Shabab⁸ militia launched a general offensive against Mogadishu, which the government was able to repel only with the assistance of the pro-government militias. Because of the sudden and large-scale deterioration in the security situation, President Sheik Sharif Sheikh Ahmed declared a state of emergency and asked for a military intervention of the neighbouring states.

In 2010, Al-Shabab carried out an attack in the Ugandan capital claiming the life of 76 people and it intensified its attacks against the AMISOM troops. In addition, the terrorist organisation conducted a series of attacks on various institutions in Kenya kidnapping civilians there. As Al-Shabab gained ground, the chairperson of the African Union (Au) Commission Jean Ping requested further reinforcements from a number of African countries⁹.

On 16 October 2011, Kenyan troops launched the “Operation Linda Nchi” (OLN: Protect the Nation)¹⁰. A joint offensive of the TFG, AMISOM and Kenyan troops seriously damaged the capabilities of the terrorist organisation, driving its formations away from the greatest part of the territories under their control, thus forcing them to give up several settlements of strategic importance. Following the operation, Al-Shabab decided to modify its traditional fighting methods and opted for pursuing guerrilla warfare accompanied by terrorist actions.

In 2012, the Au once again requested the uN Security Council (uNSC) to contribute to an increase of the AMISOM personnel and provide further funds for stabilising the already achieved results and for expanding – in line with the strategic concept – the operational area. The uNSC issued its resolution No. 2036¹¹ proposing the increase of the AMISOM personnel. In the course of the II Somalia Conference held in Istanbul, the participants outlined that the country had entered into a new phase of peace building, and in the framework of this process efforts should be taken so that a new government could be elected.

In August and September 2012, the country officially declared its transitional period to be ended. The key milestones of this period were the adoption of the new Federal Constitution, the establishment of the new Parliament and the election of the country’s new President.

Risk factors

In 2008, the uSA and uN sponsored *Food Security Analysis Group* stated that the number of refugees and displaced persons depending on humanitarian aid was radically increasing. Those leav-

5 An armed clash broke out between the fighters of the Marehan and Majerteen clans belonging to the 1st Somali Brigade at the sieges of Kismayo in 2007.

6 ArS-D refers to the Djibouti wing of the Alliance for the re-liberation of Somalia.

7 The peacekeeping forces of the African Union in Somalia are referred to as the African Union Mission in Somalia (AMISOM).

8 Al-Shabab is the Somalia-based cell of the militant Islamist group al-Qaeda.

9 Angola, South Africa, Ghana, Guinea and Nigeria.

10 Its primary aim was to establish a buffer zone to a depth of 100 km from the Kenyan-Somali joint border, while the secondary one was to annihilate the armed groups of the al-Shabab movement.

11 resolution 2036 (2012): Security Council requests African Union increase troop levels of Somalia Mission to 17,700, establishing expanded presence in keeping with Strategic Concept.

ing their homes originated primarily from Central-Somalia and Puntland, which are famine and drought stricken territories. Accommodation and assistance of the refugees and displaced persons heavily burdens both Ethiopia and Kenya.

As from 2007, the famine, the withdrawal of the radical Islamic warriors, the inefficiency of the government forces in securing and protecting the maritime border and in preventing illegal fishing all have contributed to piracy gaining ground. The process was further strengthened by the fact that in Somali opinion the foreign fishing ships violated the country's territorial waters, thus any action against them was lawful. As a reaction to the Somali attacks against the foreign ships crossing the maritime area, the international community decided to send a naval force to the scene.¹²

Relations between Puntland and Somaliland have remained unsettled. One of the main reasons for the conflict is the fact that neither side controls officially the Sool and Sanaag areas of disputed territorial status. The conflicting sides try to put pressure on each other by establishing local councils, launching limited attacks and concluding contradictory agreements, while the locals constantly change their civic allegiance. These efforts end up in armed conflicts, as a rule. The once British colony Somaliland insists on its independence, while Puntland supports the TFG.

The TFG armed forces are hastily organised and non-transparent both in their structure and in personnel, thus opening the way for corruption. The armed personnel still consist of clan¹³ members in permanent rivalry with each other. Wavering loyalty and the insubordination of the TFG troops continues to pose a serious problem.¹⁴ Ethiopia contributes to a significant extent to the training of the soldiers and equipping them with defence materials.

Since 2005, it has been a permanent challenge for the local powers to decide where to situate the headquarter of the government and its organs. In 2005, Jahwar and Baidoa were the capitals of the country, while in 2006 – due to Yemeni pressure – the government finally decided to move to Baidoa. In 2007, several government organs removed to Mogadishu. In 2009, following the withdrawal of the Ethiopian troops, Al-Shabab troops and the forces of the Islamic Front of Somalia (IFS) occupied Baidoa, and so numerous parliamentary delegates left the country.

In 2007, the government started its reconciliation programme with the aim of getting the moderate SCIC members to join the TFA. In 2008, the ARS-D accepted the government conditions and formed a government of unity following the presidential elections. However, the rivalry among the clans loyal to the TFG cast a shadow on the reconciliation process. The opposition forces including the Al-Shabab terrorist organisation, the JIS, the Anole opposition group and the ARS-A decided to form the Islamic Party (Hisbi Islam/HI), which is still unwilling to reconcile with the government, its armed groups still attack the TFG forces and their supporters.

Moreover Somalia is characterised by extreme poverty, drought, famine and a largely destroyed infrastructure. At the same time, despite these enumerated problems, the country witnesses dynamic and lively economic activity, the reason for which is the fact that a number of Somali port cities¹⁵ represent an entry point for foreign goods to the entire network of African commerce. In addition, livestock breeding is also a key factor of the country's economic potential. The primary foreign markets of Somali livestock farming are the countries of the Arab Peninsula. The Gulf Countries¹⁶ profiting from Somalia's dependence significantly influence its politics and economics. The fi-

12 No. 1816 UNSC resolution was taken in July 2008.

13 Majerteen sub-clan, Marehan clan, rahanwhein clan as well as the Abgal and Saad sub-clans of the Hawiye clan.

14 In 2008, a significant number of TFG fighters left the armed forces and joined the militias, and in a number of cases the soldiers denied carrying out the orders.

15 Mogadishu, Marka and Kismaayo.

16 Saudi Arabia, Yemen and the United Arab Emirates.

nancial assistance of the Somali Diaspora also significantly contributes to the country's economic output, performance and standard of living.

The anti-government armed groups continue to represent a serious threat to the government and its allies. The HI and its members are committed to their fight against the government and the international forces, and are not willing to reconcile with the government. For this reason, the HI permanently attacks the armed forces and civilian officials of the government. The financial assistance of the Diaspora is also a key factor of the financial resources of the government forces.¹⁷

Reaction by the International Community

The uN attempted to manage the deteriorating security situation in Somalia by setting up the uN Operation in Somalia (uNOSOM) in 1992. In support of the uN efforts, the uS launched its own Operation Restore Hope, which later was integrated into the reorganised uNOSOM II operation. However, these operations failed to bring the expected results, taking a heavy toll on the side of the international forces.¹⁸ In 1995, the UN definitively withdrew its forces from the country. Since that time, it has taken political steps only to put pressure on the conflicting parties.

In 2009, the European union (Eu) started its training mission, the EuTM-I¹⁹ in uganda with the aim to train the detached Somali forces in the framework of a thorough and high-quality training programme under the control of Eu and ugandan military advisors. The training mission proved to be inefficient due to the high costs of the training activity, the poor motivation of the Somali soldiers and their largely different religious background. Despite its obvious failure, the initiative proves that Europe is very interested in settling the security situation of the region.

In 2006, the Somali government asked for military protection from the Au and the Arab League and requested peacekeeping units to be deployed on Somali soil to take part in the establishment of its armed organisations.²⁰ The Ethiopian government – as an Au member state – accepted the mission and marched into the country. Following the defeat of the SCIC, the Au remained committed to setting up a peacekeeping unit supported also by the uNSC.

Following the request, uganda and Burundi sent almost 2,350 troops to the country in 2007, while other donors²¹ failed to send troops in the framework of the AMISOM.²² The Au demanded uN participation in the mission, however it was ready to support the mission only with a smaller contingent of civilian and military advisors.²³ In its No. 1772 uNSC resolution (2007), the uN reminded of the weaknesses of the AMISOM, thoroughly examined the available options for supporting its forces. Despite the Au demand, the uN decided not to take over the mission. In 2011, the Au initiated the units taking part in the operation OLN and joining the AMISOM.

17 Certain international organisations estimate the financial assistance from the Diaspora at a sum of 500 million and 1 billion uSD.

18 In 1993, 24 Pakistani and 18 US troops lost their lives in fighting with the Somali National Alliance.

19 The establishment of the European union Training Mission-I was endorsed by the uN in No. 1872 uNSC resolution in 2009.

20 In terms of their mandate, the Au troops are required to help the TFG in consolidating its control over the entire area of Somalia and are supposed to train the armed forces. The plan envisaged the deployment of three battalions in the area of Mogadishu and Kismaayo (II Sector). In the second phase, the plan envisaged deploying a force of six battalions all over Somalia, including the I and III sectors, except for Somaliland.

21 Nigeria, Ghana, Malawi.

22 Currently the AMISOM personnel totals almost 8,000 troops, including 3,520 soldiers from Burundi and 4,480 from uganda.

23 The uN peacemaking mission established in the country in the period from 1992 to 1995 (uNOSOM) was unable to perform its mission, due to its failure the uN did not want to get directly involved in the new mission.

Somalia's foreign relations well reflect the territorial dividedness of the region. Puntland maintains good relations with Ethiopia, and is prone to frequently exploit its good ties with Addis Ababa even against Somaliland. Its informal relations with Yemen make it possible for Puntland to discuss their fishing disputes. The US had continuously supported its intelligence service; however, because of increasing piracy, the relations between the US and Puntland had become marginal.

Somaliland maintains low-level formal relations with Ethiopia. At the same time, the two countries signed a trade agreement in 2002. In terms of this agreement, Somaliland allows Ethiopia to use its port of Berbera. The inter-clan conflicts frequently spill over the frontiers. In 2008, the parties had talks on deepening their commercial and security relations. Somaliland has had several commercial disputes with Djibouti, yet following 2009, it intensified its economic, political and security relations with the country. South Africa has officially acknowledged the independence of Somaliland. The relations between the USA and Somaliland are balanced, due to the close cooperation between the intelligence organisations of the two countries.

International Organisations, Gulf Countries and China

The TFG enjoys all-out support from a number of international organisations²⁴ and from the neighbouring Arab states as well. The need for Somalia's territorial integrity and unity is emphasised first of all by Egypt, Libya, Saudi Arabia and the United Arab Emirates. Although the United Arab Emirates does not interfere in Somalia's internal affairs, it should be noted that the warlords controlling the country and their enterprises have their financial headquarters in Dubai.

The country signed a crude-oil extraction and exploitation agreement with China, and Chinese telecommunication companies are allowed to have a foothold in the capital. China supports the TFG with humanitarian and reconstruction assistance.

Djibouti

When proclaiming its independence, Somalia wanted to establish a *Great Somalia* by taking control of the former French colony, referred to as French Somalia, as well as Ethiopia and Kenya. After its war with Ethiopia in 1977, Somalia gave up its territorial claims, including those on Djibouti as well. In 2000, the relations between Djibouti and Somaliland became tense following the Reunification Conference of Arta, as Somaliland considered its secessionist efforts to be threatened by the conference. (For this reason it decided to boycott the event.) As a reaction to it, Djibouti decided to adopt numerous measures against the country. The Conference has negatively influenced the relations between Ethiopia and Djibouti as well, since Ethiopia saw its regional influence endangered by the initiative. On the other hand, their joint action against Eritrea²⁵ diminished the tension between the two countries.

In 2006, Djibouti entered into agreement with the SCIC and the TFG, playing an important role in the negotiations between the TFG and the opposition.

24 UNO, Arab League, Intergovernmental Authority on Development (IGAD), whose members are Djibouti, Eritrea, Ethiopia, Kenya, Somalia, Sudan and Uganda. Its aim is to support the environmentally friendly attitude of the members and boost their economic, security and political cooperation.

25 Both Ethiopia and Djibouti have territorial claims on Eritrea.

Eritrea

In the course of the Eritrean-Ethiopian War from 1998 to 2000, the conflicting sides – by exploiting the ethnic relations in the region – decided to arm some Somali groups.²⁶ In 2001, Eritrea recognised the Somali Transitional National Government (TNG). However, the country was against establishing the TFG supported by Ethiopia. For this reason, Eritrea supported the SCIC with weapons and reinforcements in 2006, and after its defeat opted to supporting the **ARS-A**,²⁷ as well as the Al-Shabab terrorist organisation and the JIS.

Ethiopia

The country supports the IGAD brokered Somali peace process, which led to the TFG being formed in 2004. The SCIC has not acknowledged the TFG and has attacked its facilities and representatives. Following a request from the **AU**, Ethiopia marched into Somalia, mopped up the SCIC fighters and withdrew from the country in 2009.

Ethiopia's interference in Somalia was not a simple peace keeping operation but a possibility for the country to get rid of the Islamic extremist groups. Because of this threat, Ethiopia maintains close contact with the **US** armed forces and carries out a series of covert operations against the groups of the Ogaden National Liberation Front (ONLF), which is an organisation supported by Somalia.

Ethiopia makes efforts both through formal and informal channels to influence the TFG and Somaliland.

Kenya

Kenya – which has a large Somali ethnic minority population in significant territories in the country – is directly interested in settling the internal crisis in Somalia. Since the Somali uprising of the '60s, the Kenyan majority identifies the ethnic group with extremist fighters and criminals. The situation is worsened by the fact that a large number of Somalis crossed the border and opted to live in refugee camps because of the ever-deepening internal crisis of Somalia. In many cases, the Somali extremists used these camps to carry out their actions against Somalia or the locals.

Moved by the serious problem, Kenya played an active role in the reunification and nation building initiatives. The country also acted as a mediator between the TNG and its opposition, as a result of which the sides signed the Nakuru agreement²⁸ in 2001. Although the agreement proved to be a failure, it led to the formation of the TFG with Kenyan support.

It was a diplomatic success that in 2009 Kenya and Somalia signed a memorandum of understanding, in terms of which Kenya undertook to support the new government in a number of fields, including various technical, security, migration and economic issues of overriding importance.

As a consequence of the continuous Al-Shabab actions and at the request of the **AU**, Kenya started the OLN Operation on 16th October 2011. Contrary to the unfavourable public reactions to Ethiopian military intervention, the Somali population accepted and supported the Kenyan military operations.

26 Somali middlemen armed the members of the Ethiopian Oromo Liberation Front (OLF), who attacked a series of Ethiopian targets from Somali territory.

27 Asmara wing of the Alliance for the re-liberation of Somalia.

28 The agreement aimed at establishing a new government.

USA

Following the uN withdrawal in 1995, the uS played an active role in the training and operation of the local intelligence organisations. Washington supported the 2006 Ethiopian intervention with intelligence data. The uS and its European allies carry out permanent HuMINT and ELINT operations in the country because of the activity of the Al-Qaeda terrorist organisation. The uS Air Force carried out numerous air raids against supposed Al-Qaeda targets.²⁹

The uSA supports the ongoing peace and nation building process in Somalia by all available means. At the reunification negotiations of Eldoret in Kenya, the US put political pressure on the negotiating parties in order to enforce the agreement, in 2009 – following President Sheik Sharif Sheikh Ahmed's inauguration into office – Washington promised political support and financial assistance to the government.

Conclusion

After the fall of President Siad Barre, Somalia has live in ongoing civil war. During the civil war Somalia has broken into parts: Somaliland, Puntland and the clan dominated region. The transitional government and the international community is seeking to unite the country, but the rivalry between the clans and the activities of radical Islamic organizations antagonize it. After the rule of the colonial system the newly independent states try to live by their own strength occupying the neighbouring areas. Somalia's dream of Great Somalia inter alia led to a war with Ethiopia. The wars and anarchic situation were favourable for the strengthening of various paramilitary organizations and radical Islamic groups especially when supported by particular states both financially and technically, and the opposition in their neighbouring countries.

The security situation in Somalia posed a direct threat to Ethiopia and Kenya, as radical Islamic paramilitary militias gained considerable influence in much of Somalia's territory. Ethiopia in 2006, and Kenya in 2011 intervened militarily in the internal affairs of Somalia, which has reduced the paramilitary militias' power and political influence. Another source of conflict is that Eritrea supports radical Somali Islamic organizations.

After its unsuccessful operation (uNOSOM), the uN is trying to put political pressure on the parties in the conflict. It also supports the African Union's peace operation (AMISOM), which aims to ensure a peaceful transition, support the transitional governmental structures, implement a national security plan, train the Somali security forces, and secure humanitarian activities. As a result all of these efforts, by mid-2012 the milestones of a new political system were established.

Despite the progress achieved, the new leadership will continue to face the tribal conflicts and extremist Islamist movements, while the government should seek elimination of the high level corruption, stabilization of the security situation which will create a foundation for the development of the country, and overcome the drought, the high unemployment. All the factors that give basis for economic-driven piracy, social and humanitarian disasters.

Stabilizing the situation in Somalia is impossible without the collaboration of the Somali communities and without the direct support of the neighbouring countries and the international community – and as it is well-known, all kinds of problems and conflicts that go far beyond the borders of Africa's Horn.

²⁹ The uSAF carried out an air raid against al-Qaeda members in March 2008, and killed one of the leaders of the Al-Shabab terrorist organisation in April 2008.

References

- Al-Shabaab (militant group). http://en.wikipedia.org/wiki/Al-Shabaab_%28militant_group%29 (23-01-2013)
- Are the ugandan Terror Attacks a Sign of Things to Come from al Shabaab? http://www.issafrika.org/iss_today.php?ID=983 (23-01-2013)
- Kenya: Implications of the Military Offensive Against Al-Shabaab. <http://allafrica.com/stories/201110250684.html> (11-12-2012)
- Killing of Fazul Abdullah Mohammed in Somalia a blow to Al Shabaab. http://www.issafrika.org/iss_today.php?ID=1305 (23-01-2013)
- OLN, Operation Linda Inchi by Kenya; Ramifications on Geopolitics. <http://www.horn.so/oln-operation-linda-inchi-by-kenya-ramifications-on-geopolitics> (25-02-2013)
- Operation Linda Nchi. <http://www.criticalthreats.org/somalia/operation-linda-nchi> (25-02-2013)
- Post-election Violence in uganda unlikely. http://www.issafrika.org/iss_today.php?ID=1225 (17-12-2012)
- PrOBÁLD Ferenc (Eds) (2002): *Afrika és a Közel-Kelet földrajza*. ELTE Eötvös Kiadó, Budapest, pp. 142–146.
- Somalia Country Report. <http://www.bti-project.de/fileadmin/Inhalte/reports/2012/pdf/BTI%202012%20Somalia.pdf> (18-11-2012)
- Somalia: Failed State and Failing responses. http://www.issafrika.org/iss_today.php?ID=1313 (25-02-2013)
- Somalia's Islamist war chest being boosted by uN funds. <http://www.telegraph.co.uk/news/worldnews/africaandindianocean/somalia/9563506/Somalias-Islamist-war-chest-being-boosted-by-uN-funds.html> (11-09-2012)
- Somalia: To Intervene or Not. http://www.issafrika.org/iss_today.php?ID=1000 (30-10-2012) TADESSE, Eyassu (2009): Politikai hatalom és nemzeti identitás Afrika szarván. 141-149. In: CSIZ-MADIA Sándor – TARRÓSY István (eds.): *Afrika ma, Tradíció, Átalakulás, Fejlődés*, Pécs.
- The Damage Done By War in Somalia. http://www.issafrika.org/iss_today.php?ID=1192 (19-12-2012)
- United Nations Security Council resolutions. <http://www.un.org/en/sc/documents/resolutions/> (28-12-2012)

Women as Suicide Bombers

KECSKÉS Tímea¹

A discussion on suicide attacks as one of the most widespread means of modern terrorism is considered commonplace nowadays. Hardly a day goes by without news about a terrorist act of this kind in some country – primarily in the Muslim World. Suicide attacks grew as a general means of modern terrorism at the turn of the 1980s and 1990s but it was not before 11th September 2001 that experts realized the need for a complex and comprehensive analysis and interpretation of the objectives and motivations of modern terrorists. As part of this process their studies also embraced less known female terrorism including its historical, social, and religious aspects.

Suicide attackers – a historical overview

Although suicide attacks comprise one of the most shocking phenomena of modern terrorism it is not a modern age invention. Individual assassins and attackers manifesting political violence frequently appeared in various historical ages, likewise religious-messianic or nationalistic movements or cults often used violence for achieving their objectives. Research papers on terrorism use the history of ancient Zealots, the assassins of the Crusades, or the anarchists of the 19th century to illustrate the fact that self-sacrifice and suicide attacks have always been present in the history of mankind. Although the tactics of suicide attacks are frequently illustrated by the assassination of Czar Alexander II of Russia, committed on 13th March 1881, in which the attacker belonging to the organization *Narodnaya Volya* (People's Will) was also killed, this was not a typical method of terrorism, of the classic anarchist movements in the 19th and early 20th centuries.

Zealots emerged under Caesar Augustus. According to messianic predictions the rule of God can come if four great empires (Babylon, Persia, Greece, and Rome) rule in a row over Israel. According to the predictions out of these four the last one would generate the resistance of the Jews. Since the Roman Republic became an Empire when Augustus took power, Zealots – radical and fanatic nationalists of that age – regarded it timely to liberate themselves from their anti-Judean rulers. The founder of the Zealot movement was Rabbi Judas of Galilee, who called his people to rebel against the Romans around 6 A.D. saying – according to Josephus Flavius – that as a result of their struggle the Kingdom of Israel and its ancient rule (the age of Solomon) could be restored. Although their uprisings were all suppressed Zealots – also known as sicarii because they carried daggers and killed Romans and Jews collaborating with them – grew increasingly radical. After the death of Judas of Galilee their movement broke into small groups and initiated terrorist acts and uprisings then in 66 A.D. an all-out war broke out against Rome. However, the massive legions of Rome overwhelmed them, in 70 A.D. they destroyed Jerusalem, and forced the Jewish people into dispersal for nearly 2,000 years.

During the crusades in the 11th century the Assassin cult was established by Prophet Hassan-i Sabbah. It terrified the enemies of Islam and primarily those of Prophet Sabbah. The fanatic Shiites committed brutal murders in their struggle against infidels and carried out their assassinations

¹ Email: timcsikecskes@gmail.com

under the influence of opium or cannabis. Some believe that the word assassin comes from this because the Arabic word *hasisin* means cannabis user. The foundation of their faith was that their self-sacrifice and martyrdom allowed them to enter Paradise. Hassan-i Sabbah began recruiting and training assassins in the castle of Alamut, south of the Caspian Sea. By drugging them he made the highlanders embark on assassinations even at the price of their lives. While their training was top secret, the assassinations had to be executed with the largest possible publicity in order to maximize the shock-effect on society. The activities of the cult spread into the modern day territories of Iran, Syria, and Iraq too. Their targets were selected from among important political and military leaders who were personal enemies of the cult leader. Among others their victims were leader Nizar al-Mulk, who was murdered in Baghdad in 1092, in Damascus khadi Abū Saad al-Harawi, and in Aleppo khadi, Ibn al-Khashab were killed in 1099 and 1123 respectively. Although the Abbasid caliphs made efforts to root it out the assassin cult disappeared only in the 13th century at the time of the Mongol invasion.

Suicide attackers are branded with different names. One of the best known of such names is in Arabic *fedajin* – those who are ready to sacrifice themselves. The Assassins of prophet Hassan-i Sabah may be regarded as their early versions but special literature gives the same name to certain armed groups fighting against the British occupation of Egypt in the 1940s, or those fighting the regime of the Shah of Iran Reza Pahlavi. In the mid 1950s Egyptian President Nasser also had fedajins trained for infiltrating into Israel from the territory of Jordan, terrorist attacks that provoked retaliatory action from the Israeli command, resulting in the violation of the ceasefire. The fedajins were excellent at the use of all kinds of deception typical of assassins in ages past, they approached their victims disguised as merchants. In early 1995 Iraqi dictator Saddam Hussein also established a paramilitary fedajin organization whose members were trained not only for general guerrilla warfare but also for

executing suicide attacks. The command of “the martyrs of Saddam” was the responsibility of Saddam’s sons, first Uday then Kusay, and in peacetime they were tasked with the most brutal police actions and political murders. During the 2003 Gulf War one of their important missions was to prevent the soldiers of the Iraqi regular forces from surrendering to the allied forces. This group, was also tasked with suicide attacks, they had a female section too, who were provided with a special chance to express their loyalty to the regime. The fedajíns, with their distinctive markings – the black uniform and the black scarf over their faces – became one of the symbols of the Middle East.

Female assassins and female terrorists – a historical overview

Probably the most famous assassin in history was Charlotte Corday, who murdered Jean-Paul Marat during the French revolution. The word terrorist itself was also coined at that time. Marat as a member of the Jacobin Party played a very important role in the preparation of the Jacobin dictatorship, the reign of Terror and the massacre of September 1792 can also be linked to him.²

Charlotte Corday has been present in the public mind as a woman who sacrificed herself for her country she has grown into a good reference point and a kind of a role model since the 19th century. Since the French revolution many women have become world famous or have turned into symbolic figures: Sophia Perovskaya and Vera Zasulich, Narodniks from Russian; Fanni Kaplan, who shot and wounded Lenin; or Leila Khaled today.³

² www.noiterrorizmus.hu

³ Новые камикадзе -www.sec4all.net/newkamikadze.html

The narodnik movement emerged in Russia and became one of the important revolutionary factions in the 1860s. Narodniks – “those who go to the people” – regarded the Russian rural communities (obshchinas) and Russian peasantry as the driving force of revolution, unlike Marxism, which considered the urban working class in this role. Agrarian socialist narodniks were mainly middle-class intellectuals who regarded the teaching and preparation of peasantry for revolutionary changes as their fundamental task. Their ideology – influenced mostly by Mikhail Bakunin and Piotr Lavrov – included elements of both anarchism and liberalism. It was narodniks who established the underground revolutionary organization *Zemlya i Volya* (Land and Freedom) in 1861.⁴

Vera Zasulich, who attempted to murder St. Petersburg police chief Fyodor Trepov in January 1878 became an iconic member of the movement. In 1879 the movement split into two factions: *Chorniy Peredel* (Black reparation) and *Narodnaya Volya* (People’s Will). The latter included narodniks and the supporters of individual terrorism. The group carried out or attempted a number of assassinations. Their main targets included the Tsar and the members of his family, and top leaders of the administration. Sophia Perovskaya was a member of the Narodnaya Volya leadership from the autumn of 1879 and played an active role in all three assassinations – in Moscow in November 1879, in Odessa in the spring of 1880, and in St. Petersburg on 1st March 1881 which proved successful – aimed at Tsar Alexander II.

In a way the modern leftist, neo-Marxist terrorist groups shaped in the 1960’s “emancipated” women: Gudrun Ensslin, Ulrike Meinhof and Irmgard Möller were among the founders of the German Red Army Faction (RAF); Margherita Cagol was one of the founders of the Italian Red Brigades (Brigate rosse); while Fusako Shigenobu helped establish the Japanese Red Army (JRA).⁵

By that time women had become more than mere organizers and executors of assassinations and – as proven by the case of Ulrike Meinhof – they occasionally became main ideologists. The targets and victims of these groups were not only political or military leaders or the representatives of capitalism but – as proven by the blood bath organized by three members of the JRA in the lounge of the Lod airport on 30th May 1972 (25 killed, over 60 wounded) – many innocent civilians.

In the 1960s and ‘70s the traditionalism of Muslim societies regarded female participation in armed conflicts as unacceptable. However, in the early 1980s this attitude began to change and the realization of the fact that female martyrdom had more impact on the public opinion and was a stronger factor in exercising pressure. Nowadays an increasing number of terrorist organizations in Muslim countries use women for such missions or exploits, and the stereotypes related to them, in order to legitimize suicide attacks.

The motivations of suicide terrorism

According to the definition of Robert A. Pape suicide terrorism is a mode of fanatical hatred, regarding its objectives, which involve retaliation, ruthlessness, and revenge, suicide terrorism also tries to have as much influence as possible on political and economic decisions and exercise pressure on the enemy.⁶ According to Boaz Ganor, a research fellow at the Israeli International Policy Institute for Counter-Terrorism – ICT, suicide terrorism is “an operational method in which the very act of the attack is dependent upon the death of the perpetrator. The terrorist is fully aware that if she/he does not kill her/himself, the planned attack will not be implemented.”⁷

- 4 Новые камикадзе -www.sec4all.net/newkamikadze.html
 5 Ibid.
 6 PAPE (2005)
 7 GANOR

Therefore suicide attacks have become more frequent in the age of postmodern terrorism. After 2001, when the tendency of including the civil population as potential targets of terrorism was of parallel importance to political and military leaders, came the terrorists' realization, of the fact, that previously successful terrorist tactics have become outdated – particularly in the case of protracted conflicts – and that they were unable to generate the desired impact. It can be added that suicide attacks provide a low-cost and efficient technique; between 1980 and 2003 suicide attacks comprised only three percent of the total number of terrorist acts, yet they took 48 percent of the death toll. The third factor is the media presence at terrorist acts, terrorist organizations realized that the media coverage can proportionally increase with the increasing radicalism and brutality of the execution and outcome of actions. The sacrifice of human lives and the murder of mostly innocent people usually prove radical enough to make such events newsworthy. Such sensations – again through the media – reinforce other terrorists in their conviction that pressure can only be exercised through such merciless and terrifying techniques and on the other hand transmit and amplify the fear generated by terrorism. The opinion of Cindy C. Combs and Martin Slann is no surprise: terrorism is a “synthesis of war and theatre”. This description aptly applies to female suicide bombers.⁸

Both the public and some experts link suicide terrorism almost exclusively to extremist Muslim terrorist organizations and Islamic fundamentalism. This, however, can be strongly disputed because the terrorist group Liberation Tigers of Tamil Eelam (LTTE) in Sri Lanka, which has been fighting the legitimate government, is on the platform of orthodox communism, advocates ideology with racist motives, moreover, most Tamils follow the Hindu religion. yet, LTTE has many suicide attacks to their credit: since its establishment some 240 attacks have been executed by its fanatic fighters, all aimed at both military and civilian targets and this is the organization which developed and first used “suicide belts” – an explosive-filled device to wear on the waist. Nevertheless, it is also true that nowadays terrorism affects primarily Muslim countries and most suicide attacks are committed by Islamist extremists. However, this fact far from proves that either religious fundamentalism or extremism would be the only or primary cause of suicide attacks although it is an undisputed fact that the approach to suicide attacks closely depends on particular cultures.

The terrorists of the Muslim world try to justify their acts through the slogans of martyrdom and self sacrifice for their country, and aim also at making their environment accept the necessity of violence. regarding this position there has long been a debate about whether suicide terrorism can be derived from and justified with the teachings of the Quran, referring to the defence of Islam, the fight against infidels, and self-sacrifice. Since the suicide attackers of the Muslim world are devout Muslims there are many who regard the religious fanaticism of such attackers or more precisely their bigot following of the teachings of the Quran as the main motivation, stating while on the one hand the Quran condemns suicide on the other hand it praises martyrdom. “And do not kill yourself, for God is indeed merciful to you (An-Nisa Surah, 4:29)... If any of you does so he soon gets burned in fire (Hadis)”. Therefore suicide is a crime stigmatizing not only the one who commits it but also his/her family while martyrdom – besides being the primary means of getting into Paradise – is a glorious act which is a merit to both the attackers and their families.

In my opinion this discussion is linked to attempts outlined first by a group of analysts interpreting the notion of security in the 1990s. According to them, in order to understand new conflicts, such as the Hutu-Tutsi conflict in Rwanda; the ethnic cleansing in Bosnia and Herzegovina; or the terrorist attacks against the USA on 11th September 2001 the key is not the loyalty to a state or the conflicts between them but the precise understanding of identity factors beyond the sub-state level

8 COMBS-SLANN

violence (“blood and belonging”). It should be noted that this group was widely criticized – perhaps not without a cause – for defining various types of irregular and asymmetric warfare and modern terrorism as new-type conflicts. Such criticism is justified not only because these phenomena – as it has been indicated – were omnipresent in the history of mankind (and developed together with that) but also primarily because the non-state players of the mentioned events did not go beyond the *Carmswilt* (12) *strout* *re*, claiming that war is the continuation of politics by other means. There has always been in the background of civil wars, ethnic and religious conflicts, or terrorist acts political intent, even if leaders of terrorist organizations apply fundamentalist ideas for mobilizing the members of affected communities. (The cases of mentally disturbed murderers, bombers, or school gunmen cannot be regarded as security policy issues because they present a law enforcement and criminal problem.) Therefore the primary message is that terrorist leaders encouraging suicide attacks are convinced that the idea of fighting suppression can only be expressed through blowing up flesh-and-blood people. They believe that these acts have an impact which is unachievable through other terrorist means and which can produce a counterbalance to the strength, the modern armed forces, and weapon systems of the enemy.

Finally, financial considerations also play an important role in the motivations of suicide bombers and assassins, and not only at the pre-assassination stage but afterwards too, as far as the financial support to their families is concerned. regarding the situation in Afghanistan experts called attention to a spreading phenomenon: the elders of families – for financial gains – offer up their eldest sons or daughters for suicide attack missions.

Through all this I wish to highlight the fact that suicide bombings and suicide terrorism can have extremely complex motivations therefore such acts cannot be traced back to one single reason.

Female suicide bombers

Regarding suicide attackers, a few fundamental questions are to be asked: why are they used? Who and why does one turn into a suicide attacker? All these questions need to be answered with regard to female terrorists too. Comparing them to male suicide bombers it is not uninteresting to examine the differences between them as far as their causes, motivations, and their roles in society are concerned, mainly because the situation of females in the Muslim world is far from being equal to that of males.

The primary cause of using suicide attackers is that they reliably execute low-cost and simple actions requiring short training time, with a capability of causing large destruction and attracting significant media coverage.⁹ The secret of suicide bombers lies mostly with the surprise factor. Another advantage is the lack of a chance to capture and interrogate the attackers, therefore the risk of disclosing the masterminds is low. Moreover, a suicide attack is an event with a psychological effect able to further aggravate the significant losses. It may not be an exaggeration to claim that suicide attackers comprise one of the most precise and most destructive means of terrorism of our age.

The appearance of women as suicide attackers has generated a large number of conflicts among Muslim religious leaders and shocked the public all over the world. Nevertheless, – as indicated by recent events – women are given an increasing role in suicide attacks and turn into weapons in terrorist acts. According to experts females are considerably more efficient than their male counterparts at an assassination, as they can much more easily deceive the members of security forces, thus they even more frequently carry out their missions successfully. They are able to exploit the

9 ZEDALIS

general belief that women are less violent than men, and their self-sacrifice can further increase the psychological influence on and the shock to the public.¹⁰ As a result of these factors the role of women has gradually increased and was given a new interpretation in Jihad.

Although terrorism experts have long been researching who becomes a suicide bomber and why, profiling has not provided a considerable breakthrough. In Muslim social relations there is a significant difference between the social status of men and women, according to Courtney e. Martin such difference is not detectable at the motivation level of suicide attackers. Religious fanaticism, fighting oppression and violence, and disappointment are typical for both male and female terrorists.¹¹

There is little information available on which social strata is to be regarded as a target group selected for carrying out suicide attacks or who prove to be fittest for executing assassinations. Mostly it is age which can be identified with relative precision and supported with statistic figures. Most suicide bombers are in their twenties although a teenage-terrorist has also been identified. On the other hand suicide bombers over 30 are rather rare. However, there is not very much information on other factors necessary for the typology of suicide bombers. It cannot be clearly identified whether members of the middle class or from the lower social strata embark on terrorist attacks, whether educated or uneducated youth is more involved. However, it can be definitely stated that there are independent organizations established exclusively for their recruitment possessing efficient means to have young people execute terrorist acts. It is very frequent that orphaned youth are recruited (e.g. in Palestine); girls are sold (in Chechnya); but pressure is exercised in other ways too. The majority, however, is comprised of young volunteers joining of their free will believing this is the only way to give their life an objective. Factors moving these young people toward suicide attacks can be very different: social and economic situation; cultural, religious, and family traditions; environment stricken by political violence; personal grievances; revenge; hatred of an enemy; patriotic emotions; or sacrifice.

In the case of women, it is even harder to tell why they become suicide bombers. The primary question is whether they should be regarded as vengeful and ruthless in the execution of a bombing as men, or we should accept woefully that Muslim women are mere devices and victims of terrorism. Since in most cases these women are from traditional societies where women are still inferior to men, many experts consider it doubtful that these women choose this role of their own accord. These experts pose the question: if the Jihad is not obligatory for women, why should they still participate in it voluntarily? Their viewpoint is frequently supported by the media which tends to present these women as victims of terrorism and as mothers and wives, not as cold-blooded killers who are ready to die and murder civilians out of vengefulness.

Russian journalist Yulia Yuzik dedicated an entire book to the topic of suicide bombers, titled *Brides of Allah*. She got in touch with the families of the so-called *Shahidkas* or *Black Widows* after the hostage crisis at the Dubrovka Theater, which took place between 23rd and 26th October 2002, in order to find the motivations of the suicide bombers and their reason for choosing certain death, for some kind of sublime goal. Although some of the women in this book are widows whose husbands were killed by Russian Special Forces, Yuzik classifies the *Shahidkas* into two categories.

On the one hand she distinguishes between those 15 to 19 year old girls who were sold by their families in order to prove their dedication to terrorism and who were thus forced to commit a suicide bombing. In their case Yuzik identified no motivation or urge for self-sacrifice. The primary reason for their sale was the financial support the Chechen families

received from the recruiters.

10 ZEDALIS

11 MARTIN (2008)

Although in some cases young girls are not purchased but kidnapped, in most cases it is their family that compels these young women to become Shahidkas by their dedication to terrorism. And the girls obey either believing that by their death they restore the honour of their family or simply because these women have no voice, no independent opinion and their sole task is obedience. They do not want to die but nobody asks them.¹²

“The second group consists of the unhappy. They are thirty to forty years old and tragedies have defined their entire lives. They lost their husbands, children or houses. Their lives are in ruins, and they can be easily convinced to take revenge”, writes yuzik. The main differences between the two categories are the methods of their recruitment and the nature of their motivations.¹³ For the recruiters of terrorist groups it is easier to find volunteers from the second group. In their case it is easier to justify dying as a form of revenge for the atrocities and cruelties that have befallen their families. In the initial phase of their training, for both groups, these women are separated from their families in order to brainwash them. Drugs, various narcotics, sexual abuse are used – in order to diminish their chances of marriage – and other violent means are used during their preparation for the bombing. They are made to believe that as a reward for their action they will gain entrance to Paradise where they will meet their lost family members.

According to yuzik, in many cases they do not blow themselves up but it is done by a remote control. She writes “The bombs are attached to them and are detonated from a distance.” Thus they do not need any kind of training or preparation. They are not trained in the use of firearms, terrorist organizations regard them as living bombs.

Therefore it is hard to decide whether they are victims or independent terrorists choosing death voluntarily of their own will. There are plenty of examples for both cases, therefore generalisation would be rushed. However, it is certain that the competent authorities must respond to this relatively new phenomenon with new devices and methods. Despite the traditions of Muslim society, in cases of conflicts women must be regarded as equal to men and must be viewed with the same suspicion.

Recruitment, training, technical preparation

Suicide bombings have few ingredients: take a human body, train it, attach a lot of explosives to it, take it to the target, and then blow it up. There is no shortage of human bodies since recruitment provides a steady supply of potential perpetrators for suicide bombings. In many places, “conscript- tion” is advertised on posters with the portraits of previous suicide bombers. The most common practice is that the female members of the terrorist group recruit those who they believe they can brainwash and convince to sacrifice themselves. One of these recruiters, Samira Ahmed Jassim, who became known as “the mother of the believers”, was tasked to recruit 80 suicide bombers as a member of the Ansar al-Sunnah Iraqi terrorist group, operational since 2003. She convinced women who had been raped to choose death, and due to their shame they volunteered more easily to sacrifice themselves in the hope of easing the pain. In February 2009 Samira Ahmed Jassim was caught and imprisoned. During her interrogation she admitted convincing, training and preparing more than 28 female terrorists for suicide bombings. In 2008 36 women attempted and executed 32 suicide bombings in Iraq while in 2007 only 8 suicide bombings were carried out by women. The increase of female perpetrators can be observed in other countries as well.

According to many experts recruitment is a pre-planned system where the elements of recruit-

12 JuZIK (2003)

13 Ibid.

ment deliberately build on each other. Independent organizations were established for recruitment and do not hesitate to use violent means occasionally. The use of drugs (LSD, amphetamine), hypnosis and sexual and physical violence are also common during preparation. The aim of these psychological methods is to make the individual assume new attitudes, abandon her old habits and environment and to lose her common sense, thus creating a new person with the identity of a terrorist executing the act by any means.

They wear the explosives under their garments in a belt or a vest, or they disguise themselves as pregnant, and it also happens that they carry the bomb to the target in bags. In regards to the substances used, the most effective explosive is C-4 but TNT, TATP (Acetone peroxide) as well as other chemicals are also in use. The kill zone of a bomb is frequently increased by the addition of metal, glass or shrapnel (nails, screws, bolts, glass balls or other sharp objects). Bomb experts also use remote controlled detonation lest the suicide bomber get caught, killed earlier, or changes her mind.

Publicity is the primary concern when choosing a target. Terrorist organizations choose busy and crowded places (the underground, hospitals, theatres, festivals or any other major event) as the scene of their bombings. They increasingly prefer places mainly frequented by women and children and try to commit efficient bombings with as much big media coverage as possible due to the high count of casualties and injuries.

Bombings and organizations

The bombing carried out on 9th April 1985 by Khyaladi Sana, a member of the Syrian Social Nationalist Party (SSNP), was the first known bombing executed by a woman. She drove into an Israeli military convoy with a truck loaded with explosives and she killed two Israeli soldiers.¹⁴ Her act was exemplary to such an extent that several similar bombings were committed in Lebanon in the very same year.

According to the databases on terrorist acts, female suicide bombers are primarily recruited and trained in Sri Lanka, Chechnya, Palestine, Iraq, Israel, Turkey and India. In this respect the Liberation Tigers of Tamil Eelam (LTTE) has the longest history. The Black Tiger – a specially selected and trained “unit” of the LTTE – is the most active suicide bomber group today. Thirty to forty percent of Tamil suicide bombings are carried out by women. Tamil suicide bombers are primarily motivated by political aims, and not religious goals, as in the case of the suicide attack against the Prime Minister of India Rajiv Gandhi which claimed not only the life of the prime minister but had another eleven victims as well.¹⁵ Likewise the Marxist-Leninist Kurdistan Workers’ Party (PKK) in Turkey also frequently uses suicide terrorists against members of the Turkish armed forces.

Among the fanatic religious organizations it is the Palestinian Al-Aqsa Martyrs’ Brigades and the Chechen Shahidkas which execute the most significant suicide bombings. In Chechnya the followers of Shamil Basayev are the most active in recruiting female terrorists who conduct their activity under the name “Garden of the Righteous”. The first woman to become known as a “Black Widow” was Khava Barayeva, who blew herself up in June 2000 and killed 27 Russian soldiers on a Russian military base in Chechnya. According to the witnesses her last words were the following: “I know what I am doing. Paradise has a price, and I hope this will be the price for Paradise.” On

27th November 2001 Ayza Gazuyeva carried out a suicide attack against Gaidar Gadzhiev, the commander of the Urus-Martan Military District in Chechnya. The young Muslim woman took revenge for the death of her husband, two brothers and a cousin who were killed by Russian Special

14 ZEDALIS

15 BEYLER (2004)

Forces. It is interesting that Chechen insurgents did not claim responsibility for her actions at that time. However this has changed by now: countless data and recordings prove that female Chechen terrorists are active participants in the terrorist attacks. Several Shahidkas participated in not only the above-mentioned Dubrovka theater crisis but in the Beslan school hostage crisis as well, and in the end of October 2008 a Chechen woman blew up a minivan in Vladikavkaz, the capital of North Ossetia, killing 8 and injuring 30 people.

It is not only the Al-Aqsa Martyrs’ Brigades which use suicide bombings in Israel, but also the Palestinian Islamic Jihad, Fatah and Hamas as well.¹⁶ The first woman to carry out such a bombing was Wafa Idris, a member of the Al-Aqsa Martyrs’ Brigades, who blew herself up in Jerusalem on

27th January 2002. She was working for a humanitarian organization when she was recruited as a suicide bomber. Presumably she chose death because her husband divorced her as she was infertile.

Palestinians do not have a common consensus concerning suicide bombings. There are many of them who criticise the participation and martyrdom of women, especially if they are wives and mothers. One of the greatest scandals was the recruitment of Reem Saleh Al-Riyashi and Ayad al-Masri, which split Palestinian public opinion. After this case, besides their families, many protested against Hamas and the Palestinian Islamic Jihad for manipulating and recruiting these women. The majority of Palestinian leaders believe that while there are enough men, it is not reasonable to involve women.

Suicide bombings are relatively frequent in Iraq as well and their number has increased recently. November 2008 saw the attack of the youngest bomber so far: a thirteen-year old Muslim girl blew herself up at a checkpoint in one of the most dangerous areas. Four people were killed and fifteen were injured in the bombing.

According to some experts, the number of female suicide bombers and bombings carried out by them is expected to increase.

BÉRÉSZ János (2007): A nők és az öngyilkos terrorizmus. In: *Felderítő Szemle*, 2007. 3. Issue, pp. 15–26. BEYLER,

Clara (2004): Messenger of Deaths: Female Suicide Bombers. In: *ICT Researcher*, 7 March, 2004

COMBS, Cindy C. – SLANN, Martin: Encyclopedia of Terrorism

GANOR, Boaz: Suicide Terrorism: *An Overview*. International Policy Institute for Counter-Terrorism.

Новые камикадзе. www.sec4all.net/newkamikadze.html

JUZIK, Julija (2003): *Nyeveszti Allaha*. Moskva, „ultra. Kultura”.

MARTIN, Courtney E. (2008): Female suicide bombers. In: *The Huffington Post*, 4 August, 2008. PAPER, Robert

A. (2005): *Dying to Win. The Strategic Logic of Suicide Terrorism*. New York, Randolph House.

PEDAHZUR, Ami (ed.) (2006): *Root Causes of Suicide Terrorism: The Globalization of Martyrdom*. <https://doi.org/10.4324/9780203964910>

London, routledge.
ZEDALIS, Debra D.: *(Female) Suicide bomber*. www.strategicstudiesinstitute.army.mil

16 BEyLEr (2004)

Another victorious presidential election – The Bolivarian Revolution and Venezuela

VOGEL, David¹

When in 1992 a military officer with a group of leftist followers tried to seize power in Venezuela, the events were enough for fifteen minutes of fame, but not more. However when the same person, namely Hugo Chávez won the presidential election in an outstanding victory six years later and started his so-called Bolivarian Revolution and initiated new methods, new approaches with fast and clearly visible results, the international community started to pay more attention, especially when similar leftist political movements began to win the elections in other countries in the region. The aim of this article is to take a closer look at Chávez himself, it is a short brief on his past deeds as the possible reasons for his continuous popularity amongst Venezuelans. Finally we shall give an overview of the needed actions in order to achieve the necessary development in the country and insure the continuity of the Bolivarian Revolution even after the late-president's death.

"A victory for Chávez is not just a victory for the people of Venezuela, but also a victory for all the people of Latin America ... this victory will strike another blow against imperialism."

Luiz Inácio Lula da Silva,
Brazilian President (2003-2010)

In 1992, a previously unknown lieutenant colonel showed up on the political scene of Venezuela in an eventually failed coup attempt: Hugo Chávez Frías. In six years, after winning the presidential election he started his so called Bolivarian revolution in order to build out a completely new social and political system in the Latin American country. Though, this step was only the first one in the continent-wide series of changes that have shaped the face of Latin America. But who was Hugo Chávez? What has happened in Venezuela since he was elected for the first time and what is the reason that the often criticized president could keep his seat after four elections? Last, but not least, what is in store for Venezuela during the upcoming presidential term: what is at stake for Venezuela?

Hugo Chávez Frías

Although originally he wanted to become a priest, Chávez – born the son of middle-class school-teachers – decided to join the military, so in 1975, he graduated from the Venezuelan Academy of Military Sciences.² even though he was an army officer, he got involved more and more with politics, opposing the ruling governments, then in February 1992, he became the leader of a failed coup

1 Email: divad.legov@gmail.com

2 <http://www.reuters.com/article/2007/05/19/us-pope-chavez-iduSN1819661120070519> (10.04.2013.)

attempt, aiming to overthrow the cabinet of President Carlos Andres Perez.³ Two years later, after receiving a pardon, Chávez was released from prison, then after having left the army, he quickly established his own party, the Movement of the Fifth Republic and he started his political career, which reached its first success in a landslide victory against Henrique Salas in the presidential elections in 1998, winning by 56.2 percent, as opposed to Salas' 39.97 percent.⁴ Even the United States Department of State report declared the procedure “a good and clean election”, showing a great difference between the two candidates, since Jaime Lusinchi defeated his opponent, Rafael Caldera in 1983, 57 to 34 percent.⁵

In less than one and a half year, after taking office in February 1999, Chávez faced another challenge: as the first great step of his presidency, he changed the country's constitution, extending the duration of the presidential term to six years. In July 2000, he got elected for the second time in accordance with the new election law, so this time for six more years. Despite all his popularity, in April 2002 – just ten years after he tried to overthrow the government – he found himself in the same situation: he was temporarily removed from power for two days. Another two years with no disturbance followed, and then a recall referendum was initiated by the opposition that Chávez eventually managed to win, in August 2004. In December 2006 came another election victory, won by 62.57 percent to 37.18 percent against Manuel Rosales, the candidate of the opposing party, *un Nuevo Tiempo* (A New Era, *uNT*).⁶

Carrying on his Bolivarian revolution, in December 2007, El Presidente initiated a constitutional referendum to lift the presidential term limits. However the results were not in his favour, Chávez rephrased the question this time to include all the elected officials: the referendum then allowed him to run for the presidency without term limits. In September 2010, Chávez and his party *PSuV*, being still popular, won the elections for the National Assembly, however, the opposition got more than 40 percent, meaning a slight increase in their support.⁷

In regards to his private life, which affected his political career, in June 2011, Chávez revealed that he had been receiving cancer treatment and nine months later he had surgery in Cuba.⁸ The disease, he said, was cured so he ran for his third full term in October 2012, receiving 55.14 percent of the votes against Henrique Capriles Radonski running on the ballot of the *Movimiento Primero Justicia* (Justice First Movement), getting only 44.24 percent support of the voters, but still making it the tightest presidential race with Chávez involved.⁹

Even though the margin narrowed down to eleven percent, Chávez remained a controversial, but popular politician, even when compared to other North and South American leaders. According to the study ‘Approval of Presidents: America and the World’, done by *Consulta Mitofsky*, a Mexican polling firm, Hugo Chávez was the fourth most popular president among twenty on the American continents with a 64 percent approval rating, right after the 80 percent of the Ecuadorian

3 The roots of his movement can be traced back to 1982, when Chávez formed a secret group of military officers. This was in fact the first time he used the name ‘Simon Bolivar’ in connection with his political actions. eventually, the riot of the revolutionary Bolivarian Movement was put down with 18 casualties, 60 people injured and Chávez giving up himself to the authorities. His fellow fighters tried to overthrow the regime nine months later, but failed again.

4 <http://www.electoralgeography.com/new/en/countries/v/venezuela/venezuela-presidential-election-1998.html> (28.11.2012.)

5 <http://www.state.gov/documents/organization/143536.pdf> (28.11.2012.)

6 <http://www.electoralgeography.com/new/en/countries/v/venezuela/venezuela-presidential-election-2006.html> (29.11.2012.)

7 Even though *PSuV* won only slightly with its 48.20 percent over the 47.17 percent of the opposition, *Democratic Unity Roundtable* (*Mesa de la Unidad Democrática, MuD*), but due to the electoral system, it gained 96 seats, while the *MuD* obtained only 64 mandates. <http://electionguide.org/results.php?ID=1518> (11.04.2013.)

8 <http://www.bbc.co.uk/news/world-latin-america-10086210> (17-10-2012)

9 <http://www.electoralgeography.com/new/en/countries/v/venezuela/venezuela-presidential-election-2012.html> (29.11.2012.)

President, Rafael Correa, President Mauricio Funes' 72 percent from El Salvador and the Guatemalan Otto Pérez with his 69 percent popularity rating.¹⁰ This score was not only 6 points higher than last year's, but also higher than the Brazilian President Dilma Rousseff's 62 percent, or that of US President Barack Obama who was only in tenth place, with a more modest 49 percent rating. But what could possibly cause such strong support for a leader who had been in power for fourteen years and had also been constantly criticised for his – sometimes radical – leftist views and political techniques and most of all because of his authoritarian attitude.

Chávez was handling issues in an opposite way to the majority of the world, he opposed the USA and had a warm relationship with Iran. Despite this, no one could have stated that he was alone with his politics, rather the opposite, he had several followers at home as well as abroad. Critics said that he was risking the future of Venezuela, he was wasting the huge oil income of the country on unnecessary projects at home and on supporting allied countries, that his system was highly corrupt and most of all that he would do anything to stay in power, taking the country to the very edge of collapse.

Four times in a row – but what was the reason behind it?

In order to have a clear picture on why Chávez was re-elected, we need to take a closer look at such important issues like the reform of the social structures: education and healthcare, and the figures showing the performance of the economy. If we compare the official data provided by the World Bank about the above mentioned topics, we can clearly see the difference between the time when Chávez took office, and data as of today. The positive development is evidently visible, and we cannot forget the fact that all social programs or big reforms need time for the implementation and for the first results to be noticeable. Besides all these, of course we need to take into consideration the negative effects of the world financial crises as well.

First, let's have a closer look at education, as one of the most important investments in a country's future. There are three important factors when talking about education and its effectiveness: government expenditure, literacy rate and the completion rate. Unfortunately not all the data for these are available on the Internet, but regarding the government spending on primary education per capita in percentage of the GDP, we can quote the data for 2006 and 2007, being 8 percent and 9 percent respectively,¹¹ showing a important increase in the educational budget. It is understandable that it is not only the money spent, but the outcome, and the efficiency that can give a more precise picture. In regards to the literacy rate¹² provided by the World Bank, we can see that the two given data referring to 2001 and 2007 show a two-percent increase from 93 to 95 percent, which is quite remarkable in such a short time.

An even wider set of data is available in connection with the primary completion rate between 1999 and 2010, showing an outstanding increase from 81 percent to 94 percent during the given

10 CAMPOS-HERNÁNDEZ (2012) p. 3-4.

11 Primary is the total public expenditure per student in primary education as a percentage of GDP per capita. Public expenditure (current and capital) includes government spending on educational institutions (both public and private), education administration as well as subsidies for private entities (students/households and other private entities). <http://data.worldbank.org/indicator/SE.XPD.PRIM.PC.ZS?page=1> (23.02.2013.)

12 According to the World Bank definition, literacy rate refers to the percentage of the population age 15 and above who can, with understanding, read and write a short, simple statement on their everyday life. Generally, 'literacy' also encompasses 'numeracy', the ability to make simple arithmetic calculations. This indicator is calculated by dividing the number of literates aged 15 years and over by the corresponding age group population and multiplying the result by 100. <http://data.worldbank.org/indicator/SE.ADT.LITR.ZS/countries?page=2> (23.02.2013.)

time of a little bit more than a decade, even reaching 98 percent in 2007.¹³

Though, not only education but the level of healthcare reveals a lot about a country's state. Regarding the health expenditure per capita between 1998 and 2010 a raise with a value of uSD 487 – from the very low level of uSD 176 to uSD 663 – means a real change in the quality and availability of the health care services, especially if we compare these numbers with those of Argentina, an increase of uSD 54, from uSD 688 to uSD 742 during the given period.¹⁴ These investments then contribute to another important factor when talking about a country's level of development: the infant mortality rate; this in Venezuela's case decreased by 35 percent from 20 per 1,000 in 1998 to 13 per 1,000 in 2011, beating Argentina's 31 percent.¹⁵

Access to improved sanitation facilities also reflects on the development of a state, this increased by 2 percent during the decade from 1998, from 88 percent to 90 percent, while during the same period Argentina could only maintain the same level of 90 percent.¹⁶

All the achievements behind these numbers are made possible by the economy's performance, mostly based on the rising of the price of the crude oil, that was as low as uSD 12.21 when Chávez took office (February 2, 1999), reached its highest value at USD 145.31 on July 3, 2008, but was at a quite high level of uSD 90.88, when the president died (March 5, 2013).¹⁷ In order to feel the impact of the huge increase in the income and the reality of the changes and the development, some relevant indicators must be examined.

The GDP per capita almost tripled. It increased from uSD 3,901 to uSD 10,810 in 14 years from 1998.¹⁸ Just to highlight the increase, let us compare Venezuela with another country from the region with similar data from 1998, like Panama with its uSD 3,845, but only uSD 7,498 in 2011, or with one of the regional powers, Argentina with a data of uSD 10,942 in 2011, reached only from a higher value, uSD 8,273 of 1998. Even though, the annual GDP growths during these years were quite extreme: they reached their lowest, -8.9 percent in 2002, but peaked in 2004 with

13 Total is the total number of new entrants in the last grade of primary education, regardless of age, expressed as percentage of the total population of the theoretical entrance age to the last grade of primary. This indicator is also known as "gross intake rate to the last grade of primary." The ratio can exceed 100% due to over-aged and under-aged children who enter primary school late/early and/or repeat grades. <http://data.worldbank.org/indicator/SE.PRM.CMPT.ZS/countries?page=2> (23.02.2013.)

14 Total health expenditure is the sum of public and private health expenditures as a ratio of total population. It covers the provision of health services (preventive and curative), family planning activities, nutrition activities, and emergency aid designated for health but does not include provision of water and sanitation. Data are in current u.S. dollars. <http://data.worldbank.org/indicator/SH.XPD.PCAP/countries?page=2> (25.02.2013.)

15 Infant mortality rate is the number of infants dying before reaching one year of age, per 1,000 live births in a given year. Level & Trends in Child Mortality, report 2011. Estimates Developed by the uN Inter-agency Group for Child Mortality Estimation (uNICEF, WHO, World Bank, uN DESA, uNPD). <http://data.worldbank.org/indicator/SP.DY.N.IMR.T.IN/countries?page=2> (26.02.2013.)

16 Access to improved sanitation facilities refers to the percentage of the population with at least adequate access to excreta disposal facilities that can effectively prevent human, animal, and insect contact with excreta. Improved facilities range from simple but protected pit latrines to flush toilets with a sewerage connection. To be effective, facilities must be correctly constructed and properly maintained. <http://data.worldbank.org/indicator/SH.STA.ACSN/countries?page=2> (26.02.2013.)

17 <http://www.quandl.com/DOE-uS-Department-of-Energy/rWTC-WTI-Crude-Oil-Spot-Price-Cushing-OK-FOB> (10.04.2013.)

18 GDP per capita is gross domestic product divided by midyear population. GDP is the sum of gross value added by all resident producers in the economy plus any product taxes and minus any subsidies not included in the value of the products. It is calculated without making deductions for depreciation of fabricated assets or for depletion and degradation of natural resources. Data are in current u.S. dollars. <http://data.worldbank.org/indicator/Ny.GDP.PCAP.CD?page=2> (24.02.2013.)

an outstanding 18.3 percent growth, being the fifth highest in the world that year.¹⁹ Other factors that could exemplify the positive progress in the economy are the current account balance and the volume of the IBRD loans.

From the extreme low uSD -4,432,000,000 current account balance in 1998, the 2011 value is 27,205,000,000 and even reached 34,098,000,000 in 2008.²⁰

The loans from the International Bank for Reconstruction and Development were always very strong arguments in Chávez's rhetoric, representing the strong dependence on an organization that is controlled by the Western World, generally interpreted as an oppressive and hostile actor, so paying off the debts was one of the main aims of the Presidente: from uSD 1,219,012,000 in 1998 to the full repayment by 2007.²¹

One can say these figures are only portions of the whole picture and that is true, however, they are still valid and the positive changes they show still exist and can give an idea as to why Chávez got support from the Venezuelans.

Despite all the progress, the social programs and the money spent on lifting the living standards of the citizens, Chávez felt that the time had come for changes in his rhetoric as well. He always portrayed himself as a strong leader who is fighting against Western neo-colonisation, the growing influence of foreign companies and organisations, and he always saw his opposition – who, according to Chávez and even some independent sources, were financially supported from abroad – to be the allies of these foreign entities. So he always called for action against these groups, and parties, in the name of defending his country. However, feeling the wind of change amongst the population, he changed his approach to the opposition, switching to a more moderate tone when referring to them and even pledging that he would work with the opposition in the future, for the good of the country, saying that he wants to be a “better president”: “I want to include everybody, including sectors of the opposition [...] I commit to being a better president than I've been these past few years. [...] I thank God and ask him for life and health to keep serving the Venezuelan people.”²²

This latter statement was a strong reference to Chávez's fight against cancer that was treated in Cuba before the elections and even jeopardised the run for the presidency, but then he himself finally declared the cancer cured and his own health to be good for another six-year term as leader of the country.

Even though the initiator of the Bolivarian revolution has passed away, his fellow party leaders and followers want to carry on his programs and not only keep up the work, but to keep a greater focus on several issues that were addressed more strongly during Chávez's campaign. The weaknesses of his presidencies were issues such as extremely high crime rates, the urgent need for the reform of the heavily oil-dependent economy and last but not least to end the growing political

19 Annual percentage growth rate of GDP at market prices based on constant local currency. Aggregates are based on constant 2000 u.S. dollars. GDP is the sum of gross value added by all resident producers in the economy plus any product taxes and minus any subsidies not included in the value of the products. It is calculated without making deductions for depreciation of fabricated assets or for depletion and degradation of natural resources. <http://data.worldbank.org/indicator/Ny.GDP.MKTP.KD.ZG/countries?page=2> (24.02.2013.)

20 Current account balance is the sum of net exports of goods, services, net income, and net current transfers. Data are in current u.S. dollars. 1998-2011. <http://data.worldbank.org/indicator/BN.CAB.XOKA.CD/countries?page=2> (25.02.2013.)

21 IBRD loans and IDA credits are public and publicly guaranteed debt extended by the World Bank Group. The International Bank for Reconstruction and Development (IBRD) lends at market rates. Credits from the International Development Association (IDA) are at concessional rates. Data are in current u.S. dollars. <http://www.indexmundi.com/facts/venezuela/ibrd-loans-and-ida-credits> (25.02.2013.)

22 <http://www.rnw.nl/english/bulletin/chavez-pledges-become-better-president> (13.11.2012.)

gap between the two sides of the population, to unite the Venezuelans. Needless to say that the successful answers to these challenges are essential for Chávez's party, the united Socialist Party of Venezuela (Partido Socialista unido de Venezuela, PSuV), in order to remain in power, not just in the presidential seat, but on other levels as well.

"Disappointed but not defeated" – was quoted many times by the international media, words coming from a Capriles student supporter, the sentence describes well the mixed feelings of the international community as well, both the united States and the European union stressing that the re-elected president should not ignore, but cooperate with the representatives of the 6.4 million voters of the opposition.²³

So what is in store for Venezuela after the elections?

Even though Chávez fought against cancer for a long time, and had received medical treatment in Cuba and Venezuela he felt strong enough for another term, the one he won, but was never sworn in for. Either he felt that the end was approaching or he wanted to have an even stronger government to match the united opposition. In order to keep his support, one of his steps at the time of the election was to move the right people to the right places, his reliable, close colleagues were put in key positions, not only in the central government, but he nominated them to run for governorships. Chávez named former Foreign Minister Nicolás Maduro to be his vice president, replacing Elias Jaua so he could run against Capriles for the governorship of Miranda, the second largest state of the country.²⁴ Although Jaua eventually lost the election²⁵ Chávez did not want to lose one of his best men, so he appointed Jaua foreign minister.

Another appointment worth mentioning is General Nestor Reverol's, who used to head the country's anti-drug efforts and. He was made the new minister of interior and justice, taking the place of Tareck El Aissami, who was named candidate for the governor's seat of Aragua.²⁶ Another high-ranking person from the military, Admiral Carmen Melendez – the first female to reach such a high rank in the history of Venezuela – was appointed the new head of the Office of the Presidency, replacing Erika Farias, who then successfully ran for the governorship of Cojedes.²⁷

When talking about newly appointed leaders²⁸ and about succession, we need to stop for a minute to look at a long-time aide and fellow reformist who happens to be the interim president of Venezuela now, after Chávez's death: Nicolás Maduro. He is considered to be one of the founders of Chávez's political movement (Movement of the Fifth Republic) and also one of the leading activists who fought for the release of Chávez when he was imprisoned for the failed coup attempt in 1992.²⁹ The 49-year old Maduro is said to have very good relations with fellow leftist leaders of Cuba, Raúl and Fidel Castro, and besides this to have extraordinary skills

23 <http://www.rnw.nl/english/bulletin/chavez-pledges-become-better-president> (13.11.2012.)

24 <http://www.huffingtonpost.com/huff-wires/20121013/lt-venezuela-cabinet-changes> (27.02.2013.)

25 <http://www.bloomberg.com/news/2012-12-17/capriles-defeats-chavez-candidate-in-venezuela-regional-vote-1-.html> (27.02.2013.)

26 Eventually winning it by 55.55 percent. <http://www.elaragueno.com.ve/region/articulo/24322/tareck-el-aissami-electo-nuevo-gobernador-de-aragua> (27.02.2013)

27 Winning the election by 63.43 percent. <http://www.vtv.gob.ve/articulos/2012/12/19/erika-farias-proclamada-gobernadora-del-estado-cojedes-9227.html> (27.02.2013.)

28 Besides these, newly assigned ministers include the positions of the minister of Information and communication, environment, agriculture and indigenous peoples, also representing key elements of Chávez's Bolivarian revolution. <http://www.huffingtonpost.com/huff-wires/20121013/lt-venezuela-cabinet-changes> (27.02.2013.)

29 <http://www.guardian.co.uk/world/2012/dec/12/hugo-chavez-heir> (10.04.2013.)

and diverse experience in international politics, let us just think about the cooperation with ALBA and UNASUR, or about the improving relationships with Russia, China, Iran or Colombia amongst many others. During Chávez's almost one and a half decade long presidency, Maduro was his eighth vice-president, but maybe with the firmest leftist views and possibly one of those with the strongest belief in the state control of the economy, anti-imperialist foreign policy and centralized political power. In many ways his character is similar to the late Presidente, and so Maduro was the perfect candidate to be the successor of Chávez, especially if we consider the duties Maduro already took over while the president was not in satisfactory health.³⁰ The *raison d'être* for the presumption was at the beginning proven by the fact that local political think-tanks were already making surveys about Maduro's popularity when he was only the vice president.

The steps for insuring the political continuity and the strength of the Bolivarian system had been made already, according to the presidential program, the big social programs, housing and the investments in healthcare and education were going to continue with even greater financial support. In his speech, following the oath of the new cabinet, Chávez called for a greater efficiency in the government, and highlighted that the Bolivarian revolution needs to continue in order to achieve a true socialist state. Even though he was receiving medical treatment in hospital, Chávez headed the cabinet meetings, many of which focused on economic issues, such as one devaluating the national currency against the US dollar from 4.3 bolivar to 6.3 bolivar, meaning a large-scale increase in prices.³¹ Many have waited for this step for a long time, but there were other necessary decisions to be made soon after the new president is elected. The diversification of the country's economy and export goods, the urgent development of the country's infrastructure, most importantly the road – and the electric systems, the elimination of the ubiquitous corruption and last but not least the normalization of the shocking crime rates. The speeches of both candidates, Capriles and Maduro as well, reveal that they share the same focuses, and in several cases even some similar programs and solutions. With all these given, the presidential election of 2013 could not offer much difference than the one that was won by Chávez.

After Chávez's death and Maduro as the interim president running for the presidency, according to one of the latest polls, done by Hinterlaces, Maduro had a 20 percent lead against Capriles, only 10 days before the presidential election on April 14, 2013.³² Like at many political rallies and other occasions, and even in articles, such as the one Maduro published in *The Guardian* two days before the election, Chávez's political successor declared that the peaceful Bolivarian revolution will continue, stressing that "there are of course many challenges still to overcome, as Chávez himself acknowledged. Among my primary objectives is the need to intensify our efforts to curb crime and aggressively confront inefficiency and corruption in a nationwide campaign."³³

Thanks to the modern electronic voting system, the official results arrived shortly after the polling stations ('mesas') had closed their doors. The results were closer than expected, though they did not change the estimated outcome: at 11:49 PM EDT the National Electoral Council (Consejo Nacional Electoral, CNE) announced that with 78.71 voter participation, Nicolás Maduro had won with 50.66 percent of the votes cast versus Henrique Capriles Radonski's 49.07

30 http://www.huffingtonpost.com/2012/10/11/nicolas-maduro-venezuela_n_1958546.html (17.10.2012.)

31 <http://www.americasquarterly.org/content/venezuelan-currency-devaluation-goes-effect> (10.04.2013.)

32 <http://www.strategic-culture.org/news/2013/04/08/venezuela-elect-president-opposition-stands-no-chance.html> (10.04.2013.)

33 <http://www.guardian.co.uk/commentisfree/2013/apr/12/my-presidency-chavez-revolution-continue> (14.04.2013)

percent share.³⁴ In my opinion, these results have a double importance: on the one hand, all of course, they reveal that Chávez's heritage, the Bolivarian revolution and socialist ideology still have the massive support of the Venezuelan people, on the other hand they also show the added strength of the personal charisma of the late-president. The exceptionally low difference of only around 300 000 votes in favour of Maduro tells that despite all the positive development and the grandiose social programs the power of the governing party PSuV is decreasing, especially if we compare it with the growing popularity of the united opposition. Maduro is failing to show a strong leader's character so far, looking less energetic than his opponent, the ten year younger Capriles, he also seems to possess weaker rhetorical skills than his late master. So the question now is that whether the actions of his government can persuade the people that they need to continue to support Maduro and the PSuV, because we cannot forget about the fact that the president is recallable by referendum.

References

- CAMPOS, Roy - HERNÁNDEZ, Ana María: Aprobación de mandatarios - América y el Mundo, Consulta Mitofsky, Distrito Federal, México, September 2012, p. 3-4.
<http://data.worldbank.org>
<http://www.americasquarterly.org>
<http://www.bbc.co.uk> <http://www.bloomberg.com>
<http://www.elaragueno.com.ve>
<http://electionguide.org>
<http://www.electoralgeography.com>
<http://www.guardian.co.uk>
<http://www.huffingtonpost.com>
<http://www.indexmundi.com>
<http://www.nytimes.com> <http://www.quandl.com>
<http://www.reuters.com> <http://www.rnw.nl>
<http://www.state.gov> <http://www.strategic-culture.org> <http://www.vtv.gob.ve>

34 <http://www.cepr.net/index.php/blogs/the-americas-blog/venezuelas-presidential-elections-2013-live-blog> (15.04.2013.)

NATO Information Operations in Theory and in Practice Battling for Hearts and Minds in Afghanistan

rÓZSA Tibor¹

The value of information has grown dramatically in our societies. We experience the speed of information constantly accelerating and the amount of information generated is also increasing. The use of social media now has a great impact both on our daily life and the Alliance decision making processes. Information Operations concept has evolved significantly in the last, almost, two decades. Lessons learned in the Balkans and in Afghanistan are particularly important for the allied countries. Consequently, member states and NATO must incorporate experience from the battlefield into doctrines.

“In all fighting, the direct method may be used for joining battle, but indirect methods will be needed in order to secure victory.”
The Art of War, by Sun Tzu

Introduction

The above Sun Tzu quote could be the signature statement concerning the importance of information operations, which are as old as warfare. Winning a battle without a gunshot has always been the ultimate victory over the enemy. The key to fighting in the information domain is about influencing adversary perceptions.

Today’s conflict in Afghanistan is also about affecting peoples’ hearts and minds. It will be critical for stabilizing the country in the future. NATO’s International Security and Assistance Force (ISAF) in cooperation with other international and national actors are doing their best to make Afghanistan a better place to live. ISAF aims to help provide security, and to contribute to a better future for Afghan people. As officially stated: “To carry out its mission, ISAF conducts population-centric counterinsurgency operations in partnership with Afghan National Security Forces.”² The nature of problems military forces face in Afghanistan is complex – asymmetric war, terrorism, illegal arms and drug trade, a multiethnic, underdeveloped nation, corruption – which requires multifaceted solutions. Information Operations (Info Ops) play a major role in ISAF mission as troops on the ground employ a great variety of assets to achieve their objectives including the capacity building of the Afghan state, particularly its security forces. Nevertheless, ISAF efforts are far from enough without making Afghan people believe in common efforts for a better future of Afghanistan and then to commit themselves to it. Afghans have to make up their minds and decide at the end of the day.

Information Operations concept has evolved significantly in the last two decades. Lessons learned in the Balkans and in Afghanistan are particularly important for the allied countries. Consequently, member states and NATO incorporate experiences from the battlefield into doctrines.

1 Officer at the Joint Force Command in the Hungarian Defense Forces, PhD student in Military Science Doctoral School, served as PrT Commander in Afghanistan in 2007-2008. Email: trozsa22@gmail.com

2 International Security Assistance Force (ISAF): Key Facts and Figures.
<http://www.nato.int/isaf/docu/epub/pdf/placemat.pdf> (04.01.2013.)

This article argues that Info Ops play an increasingly important role in Alliance operations and it is reflected both on the battleground and in conceptual papers. It also says that the integrating role of Info Ops has to receive more attention by experts and decision makers. It starts with a short description of national doctrines: the recent evolution of the most influential US doctrine; the UK doctrine which may accumulate century old experiences; and the doctrine of the freshly experienced Hungarian participation. It continues with the presentation of the commonly developed Alliance doctrine, which will be followed by the relevant experiences in Afghanistan based on articles and personal experiences as PrT Commander in Baghlan Province, in the northern region of Afghanistan.

Overview Information Operations' doctrines

Info Ops have different interpretations among NATO countries as Info Ops doctrine has been evolving for the last decade. It's not surprising that the first Info Ops doctrine was published by the uS Army in 1996, and the latest version has recently been released. As a result of lessons learned from operations over the last decade, major improvements have been made by many countries regarding these doctrines. NATO also published its Allied Joint Doctrine for Information Operations (AJP 3.10)³ on this subject in November 2009. However, different approaches still exist and this topic continues to generate much debate⁴ amongst experts. It is in line with the rapid changes occurring in the information environment in the last couple of years. "The Information Environment comprises the information itself, the individuals, organizations and systems that receive, process and convey the information".⁵ We experience that the speed of information constantly accelerates, the amount of information generated is increasing and the use of social media is having a great impact both on our daily life and Alliance decision making processes. The value of information has grown dramatically in our societies.⁶

United States

The latest uS joint level doctrine, JP 3-13 Information Operations⁷ has been recently published. It is the newest of its kind, and it contains the most recent lessons learned from operations in Iraq and Afghanistan. "Info Ops are characterized as the integrated employment, during, military operations, of information-related capabilities in concert with other lines of operation to influence, disrupt, corrupt, or usurp the decision making of adversaries or potential adversaries while protecting our own."⁸ If we compare it with the previous Info Ops doctrine, dated 2006, we can find that almost the same notion is being used in both. The main difference between this one and the doctrine published in 2006 is that it talks about information-related capabilities (IrCs) in general, instead of naming specific capabilities as it did earlier. The new doctrine makes a distinction among these information-related capabilities, however formerly they were categorized as core, supporting and

3 Allied Joint Doctrine for Information Operations AJP-3.10.
<http://info.publicintelligence.net/NATO-IO.pdf> (04.01.2013.)

4 CHuKA (2009)

5 MC 0422/4 NATO Military Policy on Information Operations p. 2.
<http://info.publicintelligence.net/NATO-IO-Policy.pdf>

6 HAIG (2009) p. 77.

7 JP 3-13 Information Operations, 27 November 2012.
http://www.dtic.mil/doctrine/new_pubs/jp3_13.pdf (13.01.2013.)

8 Ibid. p. I-1.

related capabilities in previous doctrine. These **IrCs** are the available tools at the disposal of the commander to affect the cognitive, physical or virtual dimensions of the information environment.

I find it very important that the ultimate goal of Info Ops has slightly changed from achieving information superiority to affect adversary actions in the physical dimension. The previous doctrine, dated 2006 mentioned information superiority more than 20 times while in the new doctrine it is discussed only in relation to information assurance. It was already in the “air”, since the **uS** Army made changes in its FM 3-0 manual⁹ in 2011, where the term information operations was “unburdened” and inform and influence activities were introduced instead of information tasks. Nevertheless the desire to compose the most effective courses of actions to shape the information environment to our favor is still valid.

The new doctrine also puts more emphasis on integrating information-related capabilities throughout the joint operation planning process and stresses the employment of Info Ops in a multinational environment. The doctrine states that the purpose of the integrated use of **IrCs** is to influence selected audiences. early lessons learned from Iraq and Afghanistan show that integrating Info Ops always lacked clear guidance¹⁰ which resulted in different implementation. Consequently integrating **IrCs** is a key question to the whole model and the doctrine gives detailed direction in the context of the influence relational framework. experiences prove that Info Ops is not about possession of capabilities. For that reason the doctrine argues¹¹ that it is not the ownership of the capabilities and techniques that is important, but rather their integrated employment in order to achieve desired end state.

Though integrating **IrCs** is the real challenge for the Info Ops staff at every level, since experiences show that nobody wants to be coordinated because capabilities do not want to “lose their face.”

United Kingdom

The latest joint level Info Ops doctrine¹² in the **uK** was published in 2002, which obviously does not reflect any lessons learned from the latest NATO operations. The definition of Info Ops is very similar to the definition in the previous US doctrine. It is defined¹³ as co-ordinated actions to influence an adversary by undermining his will and decision making ability while protecting one’s own decision making processes. Influence activities, counter-command activities and information activities are the main aspects of Info Ops. Their focus is on influencing will and affecting those capabilities that directly enable the application of will. In comparison to the current **uS** doctrine it is noteworthy to point out that only media operations and CIMIC are mentioned as related activities. It is also important to note that Info Ops activities intend to influence not only adversary and uncommitted groups but allied audiences as well.

After reading the new US doctrine I find JWP 3-80 a bit outdated since it lacks apparent direction on integrating and applying information related capabilities. As it will be discussed later, this doctrine’s greatest value is that it served as a solid base for NATO’s Info Ops doctrine which was

9 FM 3-0 Operations

<http://www.kmimediagroup.com/files/FM3-0.pdf> (14.01.2013.)

10 CoxMajor Joseph L. Cox: Information Operations in Operations Enduring Freedom and Iraqi Freedom – What Went Wrong? **uS** Army School of Advanced Military Studies, Fort Leavenworth, Kansas Ay 05-06

<http://www.fas.org/irp/eprint/cox.pdf> (13.01.2013.)

11 Ibid. I-5.

12 JWP 3-80 Information Operations

http://ics-www.leeds.ac.uk/papers/pmt/exhibits/2270/jwp3_80.pdf (15.01.2013.)

13 Ibid 2-1.

published in 2009. It shows how deeply the uK was involved in the creation of AJP 3.10.

No material has been found on the developing uK Info Ops doctrine, but I presume that similarly to the uS doctrinal changes, the new term will differ from the existing one. According to the latest British Defence Doctrine,¹⁴ dated November 2011, “Military operations are executed through joint action, a term used to describe the deliberate use and orchestration of military capabilities and activities to realize specific physical and/or psychological effects.”¹⁵ Joint action, as a new term focuses on influencing and effect and is divided into three categories: Fires, Information Activities and Maneuver. This concept officially brings Information Activities up to the level of Fires and Maneuver where originally the only the latter two stayed. According to this new approach Information Activities are used in the place of Info Ops and it is not clear yet what Info Ops will be comprised of.

NATO

After many years of development NATO’s Allied Joint Doctrine for Information Operations was published in November 2009. The common understanding of Info Ops seemed to be crucial for enabling the Alliance to cope with challenges in the information arena. Although finally it was accepted, three member states – uSA, Germany and Italy – had reservations concerning it, which also reflects the different approaches to this issue. The definition of Info Ops is very similar to the uK one: “Info Ops is a military function to provide advice and coordination of military information activities in order to create desired effects on the will, understanding and capability of adversaries, potential adversaries and other NAC approved parties in support of Alliance mission objectives.”¹⁶ This lengthy description is complemented by another expression of the information activities, which is intended to define influence operations. “Information activities are actions designed to affect information and or information systems. They can be performed by any actor and include protective measures.”¹⁷

Not only the term of Info Ops, but the whole Fundamentals of Info Ops are – in section II – closely related to the uK document. Therefore the focus of Info Ops is the understanding of goals and capabilities of adversaries, potential adversaries or any parties approved by the North Atlantic Council. Although there is no NATO wide accepted term for the effect-based approach to operations it is included in this doctrine. The tools and techniques that produce effects in the battle space are not new, but how to plan and execute operations is the essence of this concept. “It puts a stronger focus on cause and effect versus target-centric attrition.”¹⁸

Section IV discusses the three inter-related activity areas of information operations. First of all, “activities that focus on influencing perceptions and attitudes of adversaries.” Secondly, “information activities that focus on preserving and protecting Alliance freedom of maneuver in the information environment.” Finally, “information activities that focus on countering command functions and capabilities, by affecting the data and information that support adversaries and are used in

14 Joint Doctrine Publication 0-01, British Defence Doctrine.

https://www.gov.uk/government/uploads/system/uploads/attachment_data/file/33697/20111130jdp001_bdd_ed4.pdf (15.01.2013.)

15 Ibid 5-8.

16 Allied Joint Doctrine for Information Operations I-3.

<http://info.publicintelligence.net/NATO-IO.pdf> (15.01.2013.)

17 Ibid. 1-3.

18 Allied Joint Doctrine for Information Operations I-5.

<http://info.publicintelligence.net/NATO-IO.pdf> (15.01.2013.)

command and control, intelligence, surveillance and target acquisition, and weapon systems.”¹⁹ Info Ops is not a capability of its own, but it is an integrating function and can employ all necessary capabilities in order to accomplish desired effects. However the doctrine mentions Psychological Operations (PSyOPS), Presence, Posture and Profile (PPP), Operations Security (OPSeC), Information Security (INFOSEC), Deception, Electronic Warfare (EW), Physical Destruction (PD), Key Leader Engagement (KLE), Computer Network Operations (CNO) and Civil-military Cooperation (CIMIC) as the most important capabilities used by Info Ops. Public Affairs (PA) are described as a separate but related function. Beyond coordination of efforts and messages PA has no role in achieving Info Ops objectives.

This doctrine was accepted in November 2009. The new NATO Military Policy on Information Operations has recently been issued establishing a working group in order to incorporate current lessons learned into conceptual papers. I anticipate that theoretical documents will meet practical experiences especially from ISAF mission and nations will have broad-spectrum understanding of planning and executing Info Ops in Alliance missions.

Hungary

Hungary doesn't have a separate joint level Info Ops doctrine yet, but there is one under development and it is planned to be published in 2014. However NATO AJP 3.10 is fully accepted and used in Alliance operations. Currently both the Joint and the Joint Operations doctrine are under revision in Hungary. There is a section in the currently existing Joint doctrine about Info Ops. It attributes Info Ops as coordinating function to influence adversaries' will and capabilities and protect their own effectiveness and systems. The ultimate goal is information superiority through command and control supremacy. It played an important role in the ISAF mission in Afghanistan, as the complexity of tasks and challenges were previously described.

Recent experiences lead to the revision of existing doctrines. As Info Ops is evolving and lessons learned from ongoing operations are utilized in conceptual documents changes are expected in this approach. Info Ops will become an integrating function and its main goal will be influencing adversary actions and behavior.

Information Operations in Afghanistan

After 11 years of engagement in Afghanistan we still struggle with the “fog of war”. Even though we collected plenty of information on culture, religion, ethnic groups and tribes we have little understanding about why people do what they do. We are trained in the code of conduct and are equipped with smart cards telling us the “do's and don'ts” but still face many difficulties in understanding the big picture. We know that this is a different type of warfare and after winning the short war we are still challenged to win the peace. Much of the fight happens in the information battle space from the tactical level up to the strategic stage. All participants want to shape the information environment in their favour, yet every action they may produce intended or unintended effects. In the following part of my study I highlight some of the aspects of information operations' in the ISAF mission in Afghanistan.

¹⁹ Ibid. 1-7.

ISAF

Info Ops have played an ever increasing role in the ISAF mission since its beginning. Experiences at the beginning show that existing doctrines provided little guidance for planning, integrating and executing Info Ops tasks. As the ISAF mission evolved everybody in the chain of command seemed to realize its importance and besides firepower and maneuver, Info Ops have become the third element of combat power.²⁰ It is vital for ISAF to transmit the same message to selected audiences through every channel and at every level. But sending messages is clearly not enough; they should be supported by integrated and cohesive actions at the same time.

To achieve desired effects Info Ops should be applied in a full spectrum of operations instead of limiting it to information superiority. This should begin with a solid conceptual base providing necessary guidance on understanding how Info Ops supports commanders in accomplishing political and military objectives. A clear definition helps realize what Info Ops really is, but we also need obvious understanding on how to integrate and employ related elements. As some doctrines were previously assessed, I think there has been a great development in ISAF mission regarding this issue.

In 2007, when I commanded a PrT in Baghlan Province PSyOPS, CIMIC, KLE, (Key Leader engagement), PPP (Presence, Posture and Profile), INFOSeC and non-kinetic targeting were the main elements of information operations. Non-kinetic targeting was coordinated at the operational level and its main goal was to reach desired effects in the behavior of selected persons. In many cases multiple capabilities were used depending on the specific situation. At that time the operational level (r regional Commands) was the lowest where Info Ops posts were authorized in the structure. On the tactical level PrTs mostly had CIMIC, PSyOPS, HuMINT, EW, SIGINT and PA elements at their disposal. According to my experience PrT Commanders soon realized that these capabilities should be employed in synergy to accomplish their mission. In Baghlan Province, we integrated these elements from the start of planning our tasks. The main group whom we wanted to have a positive effect on was the great majority; the “uncommitted” population. It was obvious that in the end they decide whom to support and our goal was to establish an existing communication with them. As part of the target audience analysis process we tried to explore the most efficient channels to reach out to “ordinary” people. One good example was that we particularly supported local TV and radio stations and extensively used them to convey our messages. According to our assessment it proved to be relatively effective, but it is not simple to measure effectiveness in the information domain. The results of surveys and a recorded call-in radio program called “Ask the PrT Commander” showed that at least our messages reached some parts of the population directly. The information campaign we planned and executed was proactive and contained positive communication.

General ISAF narratives on the PrT level were:

- we are here to help and support you
- Afghanistan deserves peace and development
- we will help the Afghan people to find Afghan solutions to their problems
- central and local governments are elected to serve people
- we respect Afghan culture and religion

In addition to these basic messages there were specific campaigns on IeDs, surrendering weap-

20 Commander ISAF Joint Command's Tactical Information Directive, COIN Common Sense. Volume 1. Issue 7. p. 1. <http://www.army.mil/article/47177/>

ons and traffic rules with ISAF convoys. Furthermore PRTs extensively used billboards to advertise any specific projects or programs run by them. Surveys measured the effectiveness of what we did, but we had a very limited indication as to what Afghans really needed in order to find their own solutions to their problems.

There was more reactive communication if something “went wrong” on the strategic or sometimes on the highest political level. even if it turned out later, that the first hand information was not precise, it was hard to succeed in such situations.

Nowadays these narratives are almost the same as it is stated in the tactical directive²¹ issued by the Commander ISAF Joint Command in 2011. Info Ops still puts the population in the center and ISAF facilitates “Afghans communicating with Afghans.” At the same time there is more emphasis on informing the public on the Taliban’s idea of the future of the country. Afghan people should hear it from their own formal and informal leaders because it is the most convincing way to be informed.

regarding structure, as the information battle evolved, Info Ops posts were introduced not only on the strategic and operational level but on the tactical level as well. until then Info Ops used to be a secondary job for someone from the staff and related capabilities were keen on their separation. These days “at HQ ISAF Info Ops function sits primarily in DCOS Communication’s directorate within the Influence and Outreach branch.”²² This is a relatively small branch headed by a brigadier general. Their mission is to conduct full spectrum information operations in order to influence the behavior of friendly, neutral and enemy groups. To achieve effects close coordination and “horizontally and vertically” integrated efforts are needed. “Horizontal integration is about the link between Say and Do, vertical integration is all about the link between Info Ops staffs at different level.” Info Ops working groups make sure at every regional command that their activities are fully synchronized across the country.

Influencing the neutral majority of the civilian population has become the center of gravity of information operations. As the international community begins to withdraw its troops to reinforce our narratives and build up confidence it is even more critical. I am sure that there is enough understanding of the situation in Afghanistan to be able to apply appropriate information activities in this regard. On the other hand to counter effectively Taliban propaganda on longer terms still poses a challenge for ISAF troops on the ground.

Taliban

The Taliban in Afghanistan have a good reputation of employing their mode of fear propaganda. Even though they do not have a doctrine they make use of information techniques better than expected. “Since their removal from power in late 2001, the initially anti-modern Taliban have increasingly recognized that modern technology and media can (and even must) be utilized in support of their confrontation with the Afghan government and international community.”²³ Taliban quickly adapted to the needs of international media and audiences as well. The videos about IED²⁴ attacks or kidnapped westerners posted on YouTube are extensively watched in our societies.

21 Commander ISAF Joint Command’s Tactical Information Directive, COIN Common Sense. Volume 1. Issue 7. p. 1. <http://www.army.mil/article/47177/>

22 Ibid. p.3.

23 FOXLEy, Tim: Countering Taliban Information Operations in Afghanistan <http://www.ndu.edu/press/countering-taliban-information-operations.html> (16.01.2013.)

24 Improvised Explosive Devices

Their real aim is not the physical destruction of soldiers or civilians, but they want to generate a non-kinetic effect with a kinetic action. even if the credibility of these videos cannot be verified they reach their aim. In November 2007, BBC broadcasted news that Burkha District in Baghlan Province was recaptured by the Taliban. The next day my team and I had a school opening ceremony in that district and of course the local governor was still in power.

youTube videos would not work in the Afghan villages, because TV sets are only in some Afghan homes, basically in urban areas. However it is remarkable how local commercial media has grown since 2002, this allows people to have alternative sources of information. According to my experience TV is becoming more and more common, but in rural areas radio is still the primary media source.

So called “night letters” are used frequently by Taliban, which are particularly effective in Afghan tribal society. That is why they fear the expansion of radio and TV stations. Taliban are also good at “fear propaganda” when they kidnap or execute someone from the local community because of talking to an ISAF patrol. During my time in Afghanistan I saw interpreters wearing traditional clothes to get to the camp where they changed into jeans. As we come closer to 2014, many of our local civilian employees intend to seek refuge in the countries of ISAF nations. The understanding of local habits and knowing local people is an advantage for face to face communication, which is still a very effective way of transmitting messages in Afghanistan.

Taliban have suffered great losses from airstrikes. Therefore their communication focuses very much on ISAF airstrikes, especially on the deaths of local civilians, the so called “collateral damage.” It has a serious effect among civilian and political audiences in the troop-contributing nations. An airstrike in Kunduz, in 2009²⁵ resulted in 142 deaths including civilians and caused NATO wide humiliation and major political turbulence in Germany. This and other similar incidents lead NATO to reduce its airstrikes in Afghanistan. “Perhaps what the Mujahedeen achieved against Soviet airpower in 1980’s with guided missiles, the Taliban are achieving, 20 years later, through the power of guided information.”²⁶

All these examples show how the Taliban manipulate tactical issues in the information environment. But there are many key questions they try to avoid in their communication, such as the Afghan civilian deaths due to IED and suicide attacks, or losses they suffer from well executed ISAF raids. understandably Taliban do not talk about education – especially girls’ –healthcare, development, governance, legal issues and public security. As the world opens up to the Afghan people these topics will become the focus of their interest. For example, since 2011, the international community has built a great number of schools, this too is missing from Taliban messages and I know from experience, that girls enjoy going to these schools very much.

Summary

The new NATO policy on information operations clearly reflects how the Info Ops concept²⁷ has developed lately. Info Ops are increasingly important to cope with the demands of recent warfare and integrate those capabilities which enable military forces to influence the battlefield as it was

25 <http://www.spiegel.de/international/germany/kunduz-bombing-in-afghanistan-german-defense-ministry-sought-to-obscure-the-truth-a-684411.html> (16.01.2013.)

26 Tim Foxley: Countering Taliban Information Operations in Afghanistan
<http://www.ndu.edu/press/countering-taliban-information-operations.html> (16.01.2013.)

27 MC 0422/4 NATO Military Policy on Information Operations,
<http://info.publicintelligence.net/NATO-IO-Policy.pdf> (19.01.2013.)

described.

Although information operations is not a capability of its own it indisputably has become an integrating staff function in order to affect the battle space through information activities. In line with this progress there has been a shift in focus from information superiority to influencing in the physical and cognitive domain. Planning for effects also has become the center in NATO operational planning process.²⁸ Much work has to be done in the close future to incorporate the vast experience of ISAF and national experiences in Afghanistan. It could secure more effective and efficient operations in weak or failed states, which seem to be unavoidable in the coming years.

In Hungary as we make efforts not to lose any traditional military capability it is necessary to take into account information related capabilities as well. Capabilities require doctrine, manpower and training. Therefore, the doctrine to be published in 2014 should give a clear guidance why Info Ops is inevitable in modern warfare and should include all information related capabilities such as CIMIC, PSyOPS, HuMINT, EW, SIGINT and PA. Info Ops posts should be established on the operational and strategic level in order to plan the integrated employment of these capabilities. Commanders and staffs are supposed to be trained regularly in Info Ops and planning for information effects should be an essential part of exercises.

References

- Allied Command Operations Comprehensive Operations Planning Directive I-2.
<http://info.publicintelligence.net/NATO-COPD.pdf> (20.01.2013.)
- Allied Joint Doctrine for Information Operations AJP-3.10.
<http://info.publicintelligence.net/NATO-IO.pdf> (04.01.2013.)
- Allied Joint Doctrine for Information Operations I-3.
<http://info.publicintelligence.net/NATO-IO.pdf> (15.01.2013.)
- CHuKA, Neil (2009): Note To File – A Comparison of the Information Operations Doctrine of Canada, the united States, the united Kingdom, and NATO. In: *Canadian Army Journal*. Vol. 12, No. 2, Summer 2009.
- Commander ISAF Joint Command's Tactical Information Directive, COIN Common Sense Volume 1. Issue 7.
<http://www.army.mil/article/47177/>
- COX, Joseph L., Major (2006): Information Operations in Operations Enduring Freedom and Iraqi Freedom – What Went Wrong? uS Army School of Advanced Military Studies, Fort Leavenworth, Kansas Ay 05-06.
<http://www.fas.org/irp/eprint/cox.pdf> (13.01.2013.)
- FM 3-0 Operations.
<http://www.kmimediagroup.com/files/FM3-0.pdf> (14.01.2013.)
- FOXLEY, Tim: Countering Taliban Information Operations in Afghanistan
<http://www.ndu.edu/press/countering-taliban-information-operations.html> (16.01.2013.)
- HAIG Zsolt dr. et al. (2009): A kritikus információs infrastruktúrák meghatározásának módszertana. ENO Advisory Kft.
- International Security Assistance Force (ISAF): Key Facts and Figures.
<http://www.nato.int/isaf/docu/epub/pdf/placemat.pdf> (04.01.2013.)
- Joint Doctrine Publication 0-01, British Defence Doctrine.
https://www.gov.uk/government/uploads/system/uploads/attachment_data/file/33697/20111130jdp001_bdd_Ed4.pdf (15.01.2013.)

28 Allied Command Operations Comprehensive Operations Planning Directive. p. I-2
<http://info.publicintelligence.net/NATO-COPD.pdf> (20.01.2013.)

JP 3-13 Information Operations, 27 November 2012.

http://www.dtic.mil/doctrine/new_pubs/jp3_13.pdf (13.01.2013.)

JWP 3-80 Information Operations.

http://ics-www.leeds.ac.uk/papers/pmt/exhibits/2270/jwp3_80.pdf (15.01.2013.)

MC 0422/4 NATO Military Policy on Information Operations.

<http://info.publicintelligence.net/NATO-IO-Policy.pdf> (13.01.2013.)

Spiegel Online International: Kunduz Bombing in Afghanistan: German Defense Ministry Sought to Obscure the Truth.

<http://www.spiegel.de/international/germany/kunduz-bombing-in-afghanistan-german-defense-ministry-sought-to-obscure-the-truth-a-684411.html> (16.01.2013.)