

# Mediation and Trust

KOME – An International Journal of Pure  
Communication Inquiry  
Volume 2 Issue 1 p.1-2  
© The Author(s) 2014  
Reprints and Permission:  
kome@komejournal.com  
Published by the Hungarian Communication  
Studies Association

## Zsolt Nagy Károly

Institute of Ethnology, Research Centre for the Humanities of Hungarian Academy of Sciences

The journal KOME, just starting its second volume, is again offering its readers a wide range of texts embracing the field of pure communication inquiry. In the first text of our current issue, Viktor Németh is examining the topic of mediation in the context of the participatory theory of communication. Through analyzing practical examples of mediation, the author presents how this technique can function as the scene of problem solving right through realizing the mutual availability of the preparedness of the participating agents – let them be either individuals or constituents of a coalition – as part of the process. The key element in Németh's interpretation is that the participating agents have the opportunity to reveal their own world for the other party via the contribution of the mediator, and, as the author writes: "As a result, the agents – the existing in two or more own worlds – mutually understanding each other's own reading create a common own world. The own world jointly created this way contains the preparedness, knowledge and skills of all present and having knowledge regarding the topic. In addition, it contains the desired needs and interests as well, which should be met to terminate the problem for the agent. All of the parties concerned have access to the joint preparedness."

In the situations outlined by Németh, trust plays an important role. Its loss is part of the problem, while its recovery, or at least the bridging over its absence via the activity of the mediator is part of the solution to the problem. Losing the trust – or, more precisely, the forfeiture of the trust not yet even gained – is in the background of the processes presented in our second text as well. The baseline of Jim Schnell's study is the situation the U.S. Army has created for itself by ignoring the characteristics of the foreign culture during its operations in Iraq. As the author writes: "Making enemies when we should be making friends created significant obstacles to U.S.-Iraq relations." He thinks this was mostly apparent in that "[e]ach Iraqi owed it to himself and his family to decide whether it made more sense to cooperate with us or to cooperate with somebody else, the insurgents. Unfortunately, because of our incompetence, more and more Iraqis have made the decision that their interests don't lie with us." For solving the problem, as we can read in the text, the army "has deployed" consultants, whose task was to train the American soldiers entering cultural conflicts on the global scene to be some kind of mediators along the straightforward goals and simple methods of a very deliberate strategy. This new knowledge, that is, preparedness, which the author calls cross-cultural competence "provide[s] the ability to operate effectively in any culturally complex environment [...] Cross-cultural competence is recognized as a force multiplier that can significantly enhance operations. It can develop over time through

experience, but can also be accelerated by principled learning methods. Cross-cultural competence enables negotiation and persuasion; mediation and conflict resolution; leadership and influence; cultural evaluation, synthesis, and predictive analysis during staff planning; and other abilities that pertain to a specific geographic area." Hereafter the faint question arises in the mind of the naive reader trusting the power and potentials of communication: why an army armed by such knowledge still needs rifles, tanks and rockets?

Another type of conflicts and their peculiar solutions are in the focus of Barbara Sólyom's research study, which is rich in empirical data. Sólyom is examining the coexistence of the Hungarian majority and the German ethnic minority in a Hungarian village, particularly the self-defensive strategies of the German minority. She studies the question within the theoretical framework of social psychology, with the concept of social identity in the center. Our social identity is defined from two directions: for one, the way we identify ourselves as the member of a group, and also the way others do this with us. But "we are worried that others may judge us based on stereotypes applied to the group we belong to or that our behavior reinforces these stereotypes. This basically stems from meta-stereotypes: what stereotypes are used regarding the group according to its own individual member. These meta-stereotypes may be the source of social identity threat. They are particularly visible in case of interactions between minorities, notably ethnic groups." Sólyom identifies three strategies the minority members use to defend themselves in the examined situation: firstly, avoiding contact; secondly, dismissing or ignoring the image formed about them by the majority group; while the most complex and riskiest possibility is "coordinating behavior during social interaction. People belonging to the majority or an ethnic minority may also respond to threats against their identity by modifying their behavior in order to ensure a good impression in the eyes of their partners. This means they change their behavior in order to avoid confirming an already existing stereotype and they harmonize it with stereotype expectations applied to the group they belong to." There are several factors determining which option a member of the minority group chooses, but according to Sólyom it is certain that "[t]hose who are motivated to ensure a better image and believe in success also believe that they have the capacities necessary to choose the strategy of controlling behavior." In these conflicts the control of behavior, that is, the intentional cultural "mistranslation," as well as the common reconstruction of reality built on such mistranslations, i.e. stereotypes, evokes the scenes of the majority and the minority groups' coexistence.

The last study of this present issue – contrary to the above – is a theoretical text, in which Márton Demeter drafts a logical system "in which reversible and irreversible processes could be uniformly handled. This attempt originates in the observation that the question of reversibility not essentially emerges in logic, nor yet in temporal logic in spite of the fact that, in principle, it should be an eminent question as regards any action (where time is the vehiculum and presupposition of change). The situation is quite similar with communication theories, where the expression 'communication' usually refers to an individual process or action in spite of the fact that any process presupposes a given, timeless type for this process. This timeless or time-indifferent types are the prototypes of pure communication." Demeter's lucid reasoning is made especially exciting by the diagrammatic representations of the analyzed logical concepts, and not only because this way he promotes a better understanding of the problems – by providing a kind of an illustration – but also because he manages to incorporate the diagrams into the flow of his argument, which in turn leads to a much more complex understanding.

# Mediation as Problem-Solving Scene in the Light of PTC

KOME – An International Journal of Pure  
Communication Inquiry  
Volume 2 Issue 1 p. 3-13  
© The Author(s) 2014  
Reprints and Permission:  
kome@komejournal.com  
Published by the Hungarian Communication  
Studies Association

**Viktor Németh**

Corvinus University of Budapest, Hungary

**Abstract:** Mediation does not only mean a specific procedure or protocol but the related attitude, mindset as well. This perspective gives opportunity to demonstrate the problem in a different way than previously. In the present study the participatory theory of communication (PTC) appears as a framework which makes the communication of participants of the mediation interpretable and transparent.

**Keywords:** mediation, participation, scene, problem solving, conflict resolution

## 1. Approaches to the Problem

From amongst the problem-solving protocols – and the related approaches – the ones related to interpersonal problem-solving can be considered as the most complicated ones because the human thinking could not be fully formalized even over yearthousands.

In the western world, the theories related to problem-solving – along which later on the legal system also crystallizes – is related to the Big Three in Greek Philosophy.<sup>1</sup> The essence of this philosophy is the analysis – judgement – reasoning – criticism ridge. According to this system, we get around in the world if we try to condense new experience into the boxes, theories deriving from the past. Everything existing either is or is not in a box. The tight logical system based on the duality of „is” and „is not” and the exclusion of controversy stems from this. (Bono 1995) This is functional in every case when the circumstances existing at time T1 are identical to T2,3...n timeline, since in this case the past and the future do not vary thus the existing circumstances do not vary either in each world condition (W1,2,3...n). This system builds on the analysis and finding of causation, signification, etc. relationships. It does not take into consideration the possibility that the cause may not be found or the cause may not be terminated.

---

<sup>1</sup> Socrates, Plato and Aristotle

### 1.1. Legal boxes

The legal system of today in the European continent bases the logical system of the institution on the above mindset as well. The actors of the legal system – judges, prosecutors, attorneys – use this common language. The institutions are basically searching for the truth<sup>2</sup> when a problem appears and not the possibility for the best solution thereof. That truth along which it can judge and condemn. But what comes after the judgement? After the imposition and implementation of the sentence, either there is a possibility for the agent to somehow change the outcome of his act on his own or he is unable to do so and uses the same solution method as before. Because the subject of judgement is one of the parties involved in the problem. So, in this system, the solution of the problem is to restore the previous world condition through the prohibition or undermining of one of the agents' act causing the problem. Ergo, one of the parties is the cause of the unwanted condition, thus the possible outcome of the participating agents can be described along the winner-loser theory if they are in the legal system with their problem.

### 1.2. The problem as possibility

In a system where the problem is approached as a system of possibilities (Bono 1995), different dates can be related to – previously eventually non-existing – different world conditions. The problem between the agents indicates the need for change or modification. It acknowledges the conditions changed compared to the past and does not want to restore them. It intends to reactivate – in a different way stemming from the nature of change – the induced congestion or modification. Emphasis is put on the different way, namely this approach considers the change and the related possibilities, the new and unknown variables, as natural. It also takes into consideration the change of the date related to the given world condition, namely a new moment in time (future) cannot necessarily be linked to an argument related to an already existing past or present moment. This is one of the essential differences between the two approaches.

The other difference is that the agents become the subject of the process in the legal system, examining that which one of them has made a mistake and has deviated from the rules of the legal system.

However, the agents involved at the time of the developing of the problem continue to be present later and in the solution of it as well.

If the parties given the chance to decide on their own future situation, they compare to each other and form their position appropriate to their needs thus enabling a possible win-win outcome (Zagare 1984).

However, this result can only be achieved in the full atmosphere of trust, entirely revealing own interests and needs. The cases analysed and practical experience show that they are able to do so only under certain conditions, namely relevant manifestation of an agent's world for another agent can only be realised under certain conditions. Which means that manifestation of their own world (Horányi 2007) is mutual among the participants, furthermore, it can be detected and interpreted for the parties in – nearly – the same way. To achieve this, one of the most appropriate scenes is mediation.

---

<sup>2</sup> The truth here means the compliance with one of the conditions of the legal system.

## 2. Mediation

Mediation occurs when the participants settle their dispute jointly, voluntarily via involving a neutral and impartial third party (a mediator).

### 2.1. Mediation scene

Mediation scene is a scene where the participants have not been present yet – or at least not with the same partners. Thus, in this space – beyond the current rules of mediation (Bush – Folger 2005) – the mediator is able to guide the participants without previously expected behavioural pattern control. One of the mediator's primary tasks is to achieve that the agents participating in the process make their thoughts, feelings and views stored in their own world regarding the given conflict best available for the other participants – with as little modification as possible – thus showing their real needs, interests in a way formed and desired by the agent.

This physical space starts with the formation of appropriately discrete and relaxed atmosphere. In the space furnished by the mediator, the agents have the opportunity to form – with the active participation of the mediator – the safe scene appropriate for both their own and the common display of thoughts of challenges and modifications. At the beginning of the mediation session, not only the consciously controllable frames – rules to be obeyed during the session – but also the postural (Scheflen 1964) and proxemics (Hall 1987) dimensions being part of non-verbal communication can be formed freely according to the parties' needs. The most important features of these dimensions are that (1) with the possibility of their manifestation – contrary to e.g. legal scenes<sup>3</sup> – they supplement the agents' verbal content, increasing the easier interpretation, clarity thereof, (2) they are changing continuously, which can significantly help the dynamics of the parties' continuous communication.

By the possible use of non-verbal communication stemming from the fact that the agents are in a common space, the positive effects of field theories come into operation as well. Kurt Lewin's (Lewin 1972) or the morphogenetic (Sheldrake 2009) field theory may be referred to. When using the common scene, the agents have to be helped to be able to find the optimal use of their non-verbal communication which accounts for 65-70% of our communication.

### 2.2. The role of time in mediation

The active listening (Gordon 2010) creates a situation of trust in itself, which is indispensable for the manifestation of the own world. If there is not enough time for detection, processing of new information compared to the past – on intellectual and emotional level as well – the agents cannot integrate into their own world the changes necessary to solve the problem.

More time is necessary for widening the viewing options of the parties as in other, ordinary dispute resolution environment – e.g. in a court room. Often the parties realize during mediation time, during the so-called own time how their thoughts were formed and manifested in some missed actions in relation to the case.

It is the mediator's task to create an atmosphere of trust, to which – besides the appropriate communication techniques – it is indispensable to ensure enough time. This is a kind of attunement time which intends to ensure that the participants of the mediation feel a safe, discrete, relaxed environment for the communication.

---

<sup>3</sup> In the continental legal system neither the judge, the prosecutor, the attorney nor the represented parties are characterised by the dynamic enforcement of non-verbal communication, it is much typical in the Anglo-Saxon system. Its use is induced there during the process by the persuasion of the jury consisting of laymen.

Providing the necessary time gives the participants the opportunity to get active listening to disclose their own world. This process can proceed where the necessary conditions are met: (1) agents being able to show the problem; (2) a mediator who guides the process, follows the parties and properly detects their communication; (3) scene providing an adequate level of security; (4) enough time (quantitatively and qualitatively as well).

Significant part of this time is spent on the demonstration of emotions and fears related to the given situation. If enough time is provided to mutually demonstrate the pains related to the past grievances and the fears related to the clearly changing future, the relationship of trust between the agents may be rebuilt – this is the first step to demonstrate the own world related to the creation of the problem. If the relationship is restored on the emotional level, the agents will be able to raise awareness of the problem to be solved and search the possible solutions thereof on this – conscious – scene as well. So, not only the necessary amount of time on the appropriate scene is important but the thematic sequencing assigned to the time unit as well: (1) emotional level, (2) conscious, rational level.

### **2.3. The mediator as leader**

This scene is further refined by the mediator<sup>4</sup> to enable the agents to show, demonstrate their own worlds. By using several verbal and non-verbal techniques, in which it is common that they strengthen the competence, the own and the common resources of the participants.<sup>5</sup> Bush and Fogel started to use this term in different meaning than earlier in connection with transformative mediation. According to their interpretation – unlike the previous ones – it means capability instead of force equalizing or redistribution. Capability for all participants to become able to make the best possible decision in the given situation. Detection, observation and raising awareness in the parties of own values, strengths and capacities in order to enable them to use their solution toolbars to the fullest. So the agents participating in the conflict use the tools in their own worlds, relevant from the point of view of the solution. When using these skills, the agent participating in problem solving uses the best tools, techniques he/she is holding to demonstrate his/her own world, namely to place it in the common scene.

The main goal of empowerment or confirmation is to transform the information between the agent's own world and their shared world by minimizing the loss. This is true in case of every need related to the conflict, formulating, appearing in the agent. So, the transformer loss stemming from the passage between the two world conditions can be kept below critical level of the lack of understanding. Critical level in my interpretation means the level where information flow between the parties stops or is diverted to a direction different from the internal worlds.

By creating a positive, supporting, safe and discrete communication scene and strengthening the parties' resources, the mediator creates a previously unknown communication situation for the agents. It leads the agents judging the other party negatively, focusing on past events and therefore being in a separate position towards the future joint cooperation and search for solution step-by-step. This guiding can only be realised if during the process the mediator can follow the real-time and content needs of the parties.

---

<sup>4</sup> The mediator is an impartial, unbiased, neutral third party in the system of the transformative mediation analysed here, who does not judge, suggest or decide on the matters related to the mediation. In the types of mediation formed previously, advising or opinion-forming of the mediator was a common practice, e.g. evaluative mediation.

<sup>5</sup> The English literature uses the phrase 'empowerment' for the strengthening of the own resources.

As a result, the agents – the existing in two or more own worlds – mutually understanding each other's own reading create a common own world. The own world jointly created this way contains the preparedness, knowledge and skills of all present and having knowledge regarding the topic. In addition, it contains the desired needs and interests as well, which should be met to terminate the problem for the agent. All of the parties concerned have access to the joint preparedness. (Horányi 2007).

This means the new jointly constructed common own world to enable the involved parties to jointly define that difference/change which caused the conflict between them. To solve the problem specified on the said basis, the agents can use their own or the common resources by completing, coordinating each other.

This can be helped as a first step by the tool of parallel thinking (Bono 1994), the „own time<sup>6</sup>” by using a mediation phrase, during which the parties can describe their own views regarding the problem without interruption. This description goes beyond the factual representation, allowing the underlying – real or perceived – feelings, emotions to appear, which hindered the safe demonstration of the own interests, needs. If the agents mutually demonstrated their own readings regarding their own worlds, they mutually have the opportunity for broader insight and understanding, recognition and taking into account of the criteria and thinking of the other party.

In this phase the parties can see the problem from a different perspective, the part of their own “old” world related to the problem changes unintentionally. Thus, on a mental level they get to know something new, something different from their own, however on emotional level the agents also get closer to get to know and understand each other's perspective – that is not equal to immediate and unconditional acceptance. Getting closer is taking place because the agents get to know the thoughts, feelings related to the problem but belonging to each other's own world. Up to now, the agents replaced these thoughts, feelings – skills, knowledge – with beliefs based on intentional grounds. The specific approaches shared by the agents eliminate the emotional approach (which is mostly based on fears) related to the problem. After recognition, solely the relevant content part forms basis of the dispute, thus not the other party but the problem to be solved will be focused on.

#### 2.4. **Collective individuals**

The logic of communication of the agents may change as well through the recognition of each other's real demands, needs. Prior to the interaction on the common scene, most of the agents use communication tools, which can be described by 'either-or' logical relations. This mostly arises from the a defensive-offensive view labelling the other party as the cause of problem that is further strengthened by the case-based approach encoded in our problem-solving culture.

When meeting the other agent in the mediation space, the substitution of previous uncertainty, lack of information from the own beliefs is replaced by the necessary access to preparedness. During the first half of the mediation session, the transformation from judgement-based thinking to the system of possibilities approach during the manifestation of the agent's own world. This usually happens with significant emotional impact: crying, trembling, stuttering, shouting, long silence, etc. This transformation means the opening of the gates of the own world. The parties involved in the process, who were present until then

---

<sup>6</sup> The different schools divide the mediation process into 4-7 steps, the second phase is the own time of the agents in every case, where he/she can demonstrate his/her own insights relating to the given conflict from his/her own perspective without the interruption of the others present.

(even) as individual agents<sup>7</sup> – or they created the impression thereof, or they lived in the belief that they are and will remain such individual agents – will be part of the collective agent category by creating the common own worlds (Ws) and the associated future cooperation. Through creation of the new own worlds such a new system, actions or in other words a pattern is rationalized that are induced for the future by the changes in the past. All of the agents involved consider these changes desirable because usually this new pattern is the maximum which can be sustainably achieved with the least loss by drawing from the joint preparedness of the agents. By the new pattern – which is usually a modification of the old one – the common work carried out undoubtedly overwrites the previous fears and beliefs which were previously built up by the individual agent in his/her own world during the time he/she was separated – on some level – from the other party.

This recovery process established in the mediation also strengthens and promotes the realization of and compliance with the new patterns while making space for a future new option for connection.

## 2.5. The own worlds are becoming common

In the case below, the cooperation of agents in the mediation process can be observed step-by-step:

*Couple of years ago a lady with noble ancestors and therefore socialised and living in a matching environment, living in a villa in Buda visited our mediation office. The lady arrived in an upset emotional state. As the owner of more real estates she covered her livelihood and travels abroad from leasing them. The tenant of one of these apartments, Imre disappeared a few months ago and could not be reached since. He even replaced the locks of the front door of the apartment and did not give the owner a new key. The tenant sold the furniture, tools being originally part of the apartment (washing machine, gas stove, television, radio, fridge). Gertrúd initiated the mediation, we contacted Imre, who – as we discussed – was willing to attend a mediation session. However, only Gertrúd was present at the appointed time. The lady showed strong emotional outbursts; she scolded today's youth with increased tone and volume, she expressed the destruction of the old values, her disappointment and feeling of being cheated. After some hesitation, she decided to give a last chance to Imre. Next time, both Imre and Gertrúd were present at the mediation session. Gertrúd, as the initiator of the session, explained the extent of damage she suffered and that she feels profound loss of trust against Imre. Imre explained in his own reading that he came to Budapest from the countryside half a year ago for in order to work. In a few weeks he got a job but after a couple of months he –without his fault – lost his job and ran out of his money saved. He was not able to tell Gertrúd that he could not pay because on the countryside where he came from, it is a very big shame for a young vigorous man. Therefore, instead of speaking with her, he ceased communication and replaced the lock. And he sold the furnitures of the apartment per piece in order to have something to eat. When he came to the mediation session, he already had a new job. Gertrúd was surprised to hear that such events can occur in one's life, and to hear that there weren't any friends or relatives living in that village, furthermore the necessity to buy bread*

---

<sup>7</sup> The collective agent where a group of agents collectively performs a given act and therefore the act carried out by them has more starting points.

*from the price of the stove sold. She saw that Imre sincerely regrets the events and that due to the shame he cannot dare to look at her. Getting to know the real reasons and details, Gertrúd had completely changed. She told Imre „Why didn't you tell me? We could have spoken about it.” During the further parts of the mediation session, they easily agreed on the extent of the damage, the payment method, deadline and instalments thereof and the re-instalment of the original lock.*

The realization of the first mediation session was endangered by the thinking, categorization of one of the agents in his/her own world regarding unemployed people – judging, stigmatizing the person itself. If one of the parties accepts and follows this, he/she joins the queue and together with the others – natural persons or the court – destroy further the agent's last possibilities that would allow the solution, improvement, positive change.

On the borderline of this preconception, Imre came to the mediation session – which was the second occasion – when he already had a new job. Based on his explanation, it was a motivation for him and had a positive impact on him that Gertrúd was willing to settle their dispute in the framework of a mediation session. This is the first moment where the positive change in the separate relation may be observed, where the agent detects – often unconsciously – the existence of the other agent as possible partner to solve the problem. The structured information-sharing in the common space, the description of the own world in the common scene totally modified the agent's (Gertrúd's) intention. As Imre had explained his situation in his own reading, the image of Imre, which was previously formed in Gertrúd's mind, completely changed. On the one hand, she did not speak in general (previously she scolded the young people) but she could concentrate on Imre and her own relation to him as she got proper relevant information regarding the events. On the other hand, the facts and information shared from Imre's own world had an emotional impact on Gertrúd. One of the alleged members of the 'delinquent youth' based on the unknown and intentional basis became a specific person with an own, individual life for Gertrúd. Who, compared to her previous experience – she did not have experience based on real facts with regard to young male tenants coming to Budapest from the countryside – changed, filled the place of presumptions, the relevant thoughts in her own world with specific experience.

The net effect of this was that Gertrúd realised that the theft of furniture was not an act against her personally but against the landlord of the apartment because at that moment Imre could cover his needs only from selling the furniture.

Mediation experience shows that if the parties get to know the real motivation, they calm down, the fear eliminates resulting in that the rational thinking gradually takes the place of the emotional approach. They start to find the solutions, protocols to be used jointly in the future. By thinking rationally of the extent of claim for damages, both Imre and Gertrúd said the same amount of money. Gertrúd accepted the solution of payment in instalments because she knew that Imre lives from month to month, he has no money saved and there is nobody from whom he could borrow.

## 2.6. Community mediation

So far the cases with small number of participants and the relations between them during mediation were examined. The number of parties involved – based on own experience – may reach 40-50 people as well, the result of the mediation – also based on practical experience – may affect a city with thirty something thousand inhabitants. Such a big number of participants practically seems to be unthinkable and impossible to deal with even in terms of

the time available. How is it possible to demonstrate so many own worlds during such short time?

Nevertheless, the community mediation can be divided into two main groups: (1) the goal is to solve a given problem having the same meaning for every participant from the beginning – such as e.g. changing a city's traffic order; (2) restoration of a specific damage, namely supporting, listening to the parties during the offender-victim mediation<sup>8</sup> or participation of the persons indirectly affected as audience. Such as for example a school fight where the aggrieved party is present as well as the perpetrator or perpetrators and the supporters too who help the parties to reach the best reparation solution. In this case the supporters are the parents, friends, classmates, further actors may be teachers, school psychologist, etc.

Community mediations are also developed to change an existing pattern, habit or to create a system not existing before. However, the interests, needs are completely clear, they are not hidden, or just a very small part of them are. Thus, the community mediation sessions are about the problem statement and searching for solution on a conscious, rational level.

The responsibility of the mediators to properly choose the appropriate representatives of community interests is bigger as in case of other mediations. To properly demonstrate the problem to be solved and articulate the associated needs, demand, it has to be represented on the session by those who have proper knowledge of and access to the preparedness. The identification of and searching for the persons with proper competence, making appointments, etc. requires much time, sometimes even one or two months. However, this ensures the opportunity of community feedback: affected people may appear who previously have not been solicited, either by contacting the organisers on their own initiatives or on recommendation. There are mediators, who deal with the preparation only, while others – usually two persons – deal exclusively with leading the session.

### 2.7. Agents in coalition

During community mediation the agents form a coalition with the other agents involved. The own capacity can be supplemented with capacities made available for each other, which can be used to recognise and solve the problem and during the communication as well (Horányi 2007).

This is exemplified by a community mediation described below which was initiated by the chief architect of the mayor's office of a Hungarian city.

The regulation of the city's traffic system did not follow a unified concept in the past decades. The change in the traffic order consisted of isolated actions of local and occasional problem-solving on an ad hoc basis: making streets one-way, parking order, placement of no stopping and no waiting signs, etc. The specific decisions were not related to each other, they did not form a structure and did not become integral part of the city's traffic order. The decision-makers did not consult with other parties concerned and competent in the given matter, due to other problems they decided on the traffic order of the city in their own way. This practice has not caused problems for a long time because the single minor decisions did not induce tensions on a community level.

The feature stemming from the geographical situation of the city possessing four different parts – downtown, garden suburb, old town, suburb – has a significant impact on the city's traffic order. This historical separation – clearly appearing on the physical scene as well – further strengthened the delay in the appearance of problems related to the traffic order

---

<sup>8</sup> Offender-victim mediation or restorative process is a mediation process where the restoration of some damage takes place.

because the user of every city part felt their own problem as specific and isolated and therefore insignificant for a long time – further delaying the feedback on the actual problem. The user of the different parts of the city – inhabitants, lorry drivers, cyclists, taxi drivers, car drivers, etc. – initially inquired, then complained in the mayor's office one by one but the individual motions have not generated significant changes. Everything the employees of the office could do was limited to listening to and registering the complaint – while they quite clearly understood the majority of the reported problems since they lived in the same city or commuted by car every day. This generated a new problem – strengthening the previous one – because thereby the employees of the office – even those officials who were not working on traffic issues – lost a lot from their professional credibility. Therefore, when they were contacted in other cases, the clients communicated with them on a lower trust level – compared to previous cases.

In this situation it was already useless from the employees of the municipality to initiate any consultation, the population did not appear or did not consider the persons initiating these professional fora unbiased. Consequently, an event where the persons concerned – all of the agents who could do something to help the case to move forward – would have been present, could not be realised. They did not consider the municipality officials impartial with regard to the developed problem.

The city's chief architect had previously participated in a municipal mediation process as observer and therefore he already knew the methodology, efficiency, financial and implementation aspects of the procedure. The project was financed by the Ökotárs Foundation, thus the city had to contribute only by providing the location in the building of the town hall twice for four hours.

The mediation session took place on two occasions each lasting for four hours. Three persons were working on the preparation of the mediation for more than two months. During the preparation, the needs of the principal, the leader of the mayor's office (mayor) had been assessed with regard to the end of the mediation:

- a) list of the traffic points to be changed,
- b) solution proposed to the points,
- c) in practice, there was no fund to carry out the changes, therefore only cost-efficient solution proposals could be taken into consideration.

The decision concerning the location and the possible dates was followed by designation of the city parts concerned and the detection of persons competent in traffic matters and their division into groups per city parts. The persons concerned were contacted via phone, in the course of which we explained to the participants the frameworks, basic rules, goal and duration of the community mediation. We adapted the selection of the participants to the city parts.

Each of the four city parts was represented by:

- assigned transport expert – one person
- representative of the local civil organisation – one person (who previously had collected information in the district)
- local resident – two persons
- expert professionally engaged in transportation being familiar with the city part – one person (e.g. taxi driver, representative of local bus company, traffic policeman)
- representative of the mayor's office – one person

Two mediators led the mediation and the preparatory mediator was present as well as the

chief architect and his colleague as representatives of the principal. Furthermore, the two representatives of the funding organisations, Ökotárs Foundation were also present as observers. Mediation took place in the assembly hall of the municipality.

On the mediation session, the goal and the formal frameworks of the meeting were described at first, followed by the introduction of the participants. After some formal questions, the proposal of the community was that the persons belonging to the different city parts started to assess, mark and to take notes on the problems regarding the traffic order on one-one map outline sized A0 separately, then when they finished it, they described it in front of the whole community. The mediators have created the groups to represent each type of the above listed agents. The community constructively criticised and supplemented the traffic-related problems collected in respect of each part of the city.

The second session took place two weeks later at the same location with the same participants. The groups worked separately again, this time to solve the problems regarding the traffic order collected at the first session. The first filter of the solutions was the need of the circulating people, the second one was the road traffic regulations – each group had an official expert – and the third one was the low financial opportunities of the city.

The groups made a total of 57 solution proposals, which complied with the road traffic regulations, met the requirements of the experts of the city's traffic department and satisfied the needs of the users of the city, they solved it on a very low budget. Specifically, via the replacement, termination and placement of traffic signs. Significant cost effects had only a blinking yellow traffic light and the painting of two road gateways.

The Traffic Department of the Mayor's Office received the proposals.

The reason of success of the above cases was the coalition on a common scene of more, manifold agents – related to the manifestation of the scene – with knowledge, skills and competence not having met in a common dimension before (Horányi 2007).

The agents with such preparedness – in addition to the proper communication holding them together – actively participated in the workshops relating to the city parts as well as in matters affecting the whole city. The latter one is crucial because the result was not five different solutions of five different city parts but the solution proposals formed by respecting the priorities specified and assigned to the goal at the beginning of the mediation session (compliance with traffic safety, low cost, acceleration of the transport, etc.). Thereby the changes necessary to be implemented for the interest of the whole community – viable transport system in the city – could be detected. The community made the persons in the workshops comply with the priorities set previously both at the time of listing of problems regarding the traffic order – the first mediation session – and at the time of developing the solutions – second session –, namely a strong controller role of the community as a whole could also be observed.

As the result of the knowledge related to the city's traffic order and cooperating in the workshop the listing of all emerged traffic problems and the possibility to change them was made possible. Even at the first meeting, the groups took into consideration opportunities reaching beyond transportation problems, but related to them (e.g. the change in the traffic order should be realised only after arrangement of community spaces). This shows that if the proper preparedness is added up well, they are not only able to solve the problem – namely to solve the problem generated in the past – but to recommend changes proactively in order to continue to find good solutions in the future. This arises from the fact that the own logic of agents participating in the coalition – which was evident in the cost-efficient, constructive thinking in favour of the city – is identical to the logic of other members of the coalition.

During the common work, the parties demonstrated their preparedness from their own world related to the specific problem to be solved on the mediation scene.

### 3. Final thoughts

The mediation – to be approached even as the alternative protocol of the court procedure or as an approach which is able to open the agents' own world to each other – is a conflict management communication process that currently cannot be replaced by anything else.

The safety, secrecy, dignity and the time of full attention, quality available in the mediation scene provides new opportunities to the agent regarding the communication and problem recognition and/or solution.

Furthermore, it also provides an opportunity to choose from the infinite number of solutions within our reach regarding the future, by respecting our sceptic approaches towards changes but overcoming them.

Because closeness is endless.

### References

Baruch, Robert A. & Bush, J. P. Folger, 2005. *The Promise of Mediation The Transformative Approach to Conflict*. San Francisco: Jossey-Bass.

Bono, Edward de 1994. *Paralell thinking*. London: Viking.

Bono, Edward de 1995. *Teach yourself to think*, Penguin Books Inc.

Dr. Eörsi Mátyás-dr. Ábrahám Zita(szerk.) 2003. *Mediáció: A szelíd konfliktuskezelés*, Budapest, Minerva. (Mátyás Eörsi, dr. - Zita Ábrahám, dr. (editors) 2003. *Mediation: The gentle conflict management*, Budapest, Minerva.)

Gordon, Thomas 2010. : P.e.T. *A gyereknevelés aranykönyve* [P.E.T. - Parent Effectiveness Training], Budapest: Gordon Kiadó.

Hall, Edward T. 1987. *Rejtett dimenziók* [The Hidden Dimension], Budapest: Gondolat.

Horányi, Özséb (ed.) 2007. *A kommunikáció mint participáció* [Communication as participation]. Budapest: Typotex.

Lewin, Kurt 1972. : *A mezőelmélet a társadalomtudományban* [Field theory in social science], Budapest: Gondolat

Schefflen, Albert E. 1964. The significance of posture in communication systems. *Journal for the Study of Interpersonal Processes*, 27(4): 316-331.

Sheldrake, Rupert. 2009. *Morphic Resonance: The Nature of Formative Causation*, Rochester: Park Street Press.

Újlaki, L. 2001. Fogalmi és terminológiai tisztázás igénye a békítés, kiegyeztetés és a közvetítés témakörében [Need for conceptual and terminological clarification in the topic of conciliation and mediation]. *Jogtudományi Közlöny* (1).

Zagare, Frank C. 1984. *Game Theory. Concepts and Applications*, London: Sage Publications.

# The U.S. Army Initiates a Proactive Approach to Leverage Cross-Cultural Understanding: The Case for the Culture & Foreign Language Enterprise

KOME – An International Journal of Pure  
Communication Inquiry  
Volume 2 Issue 1 p. 14-27  
© The Author(s) 2014  
Reprints and Permission:  
kome@komejournal.com  
Published by the Hungarian Communication  
Studies Association

**Jim Schnell**

Ohio Dominican University, Division of Social and Behavioral Science, USA

**Abstract:** This article will describe how the U.S. Army has created a culture & foreign language enterprise in an effort to leverage cross-cultural understanding in support of U.S. Army mission objectives. Topics to be addressed include problems and challenges related to cultural issues that the U.S. Army has encountered since September 11, 2001 during military operations in Pakistan, Iraq, Afghanistan and surrounding countries in the region and steps taken to address these problems and challenges.

Such topics describe the workings of the Army bureaucracy as it sought to maneuver resources in a manner that could effectively address culturally oriented issues and obstacles. The resulting approaches that have been created, funded, defended and sustained are detailed as examples of how large government institutions can persevere with agility to address such goals.

The primary focus of this article, regarding the aforementioned, is the Army Culture & Foreign Language Enterprise. The life of this Enterprise exemplifies how a vision for utilizing civilian social science Ph.D.s, in support of Army goals & objectives related to culture, came to fruition and effectively functions. This description illustrates how such an Enterprise approach can be employed in other types of settings and with other types of issues.

**Keywords:** U.S. Army, cross-cultural understanding, culture, foreign language, public affairs

## 1. Approaches to the Problem

The September 11, 2001 attacks against the United States significantly altered the context within which the U.S. Army functions. A sense of urgency became a paramount theme that has, at times, served to dilute critical thinking processes that were more prevalent in the pre-9/11 (September 11, 2001) world. The passage of time has allowed for this sense of urgency, while still there, to find its rightful place within a pecking order of priorities. This passage of time has provided opportunity for observation and reflection regarding decisions and

*Address for Correspondence:* J. Schnell, email: schnell.38[at]osu.edu

*Article received* on the 8th Feb, 2014. *Article accepted* on the 17th April, 2014

*Conflict of Interest:* The author declares no conflict of interest.

subsequent actions that have been implemented affecting U.S. foreign policy and military actions.

In his book *Fiasco: The American Military Adventure in Iraq*, Thomas Ricks describes in detail vivid mistakes that occurred in relation to cultural issues linked to U.S. Army functioning. Significant in this scenario, according to Ricks, is a lack of awareness regarding cross-cultural communication dynamics (Ricks, 2006, p. 238). His highlighting of cross-cultural concerns is couched within other themes in the book. Such topics include focus on the role of military doctrine, the Bush rationale for military intervention in Iraq, problems associated with strategy, confusion regarding the notion of counterinsurgency, misuse of the U.S. Army, cross-cultural issues and parallels with U.S. involvement in the Vietnam War.

Important cultural norms were trampled as the Army sought to achieve their objectives. “Entering the private space of the house where the women and children were, then tying up and interrogating (i.e, humiliating) the man in the house in front of his family, the premier cultural value of family honor was violated....You’ve created a blood debt when you do that” (Ricks, 2006, p. 238). Such scenarios played out over and over again during the U.S. military occupation of Iraq. Making enemies when we should be making friends created significant obstacles to U.S.-Iraq relations.

“Each Iraqi owed it to himself and his family to decide whether it made more sense to cooperate with us or to cooperate with somebody else, the insurgents. Unfortunately, because of our incompetence, more and more Iraqis have made the decision that their interests don’t lie with us” (Ricks, 2006, pp. 325-326). This is depicted as one of many cascading failures. Other such culturally oriented failures include, but are not limited to, the Abu Graib prison abuses, burnt Qur’ans, U.S. Special Forces troops urinating on dead enemies etc. It is worth noting that mass media broadcast of such failures served to amplify the depth and breadth of damage to the U.S. cause in the region and around the world.

### **A Move Toward Being Culturally Proactive**

Against this backdrop the U.S. Army leadership saw the need to address culturally oriented challenges and acted on that realization. One such action resulted in implementation of the Human Terrain System, that involves placement of social science Ph.D.s (primarily Anthropologists) on the ground with Army troops in Iraq & Afghanistan, and development of an Army Culture & Foreign Language Enterprise that focuses on creation of an Enterprise composed of social science Ph.D.s whose function is to instill culturally oriented emphasis in the education & training of U.S. Army troops. This author serves as the Lead Social Scientist of the latter. He was hired to serve as the first Lead Social Scientist of the Army Culture & Foreign Enterprise during the conceptualization stage of development and has readily observed it’s evolution and impact.

The beginnings of the Army Culture & Foreign Language Enterprise can be traced to a memo released by Army four-star general William Wallace on 4 December, 2008 that was directed to Commanding Generals/Commandants at CoE’s (Centers of Excellence) throughout the Army.

He explained “It is time to execute some initial steps to implement the Army Culture & Foreign Language Strategy (ACFLS). I want to initialize these steps even before the ACFLS is finalized in order to generate some momentum and leverage your current initiatives” (Wallace, 2008). He went on to instruct “I want you to hire a culture and foreign language

advisor. This advisor is to be a senior member of your staff to integrate all efforts across your directorates in your organization” (Wallace, 2008). Wallace was Commanding General of HQ TRADOC (Headquarters, Training & Doctrine Command) at the time and his directive carried considerable weight in the creation of the Enterprise.

This memo was reinforced with a follow-up memo from the next TRADOC CG (Commanding General), four-star General Martin Dempsey. His 22 September, 2010 memorandum to CoE CGs/Commandants builds upon the 2008 Wallace memo by stressing “On 4 December, 2008 General Wallace, CG TRADOC, issued a memorandum directing specific organizations to hire a culture and foreign language advisor. Thus far, only five of 15 CFLAs have been filled. It was noted during the Quarterly OE Review on 1 July, 2010 that organizations with CFLAs on board were making significant progress to the culture and foreign language education programs” (Dempsey, 2010). General Dempsey asserts “Commanders of organizations that do not have a CFLA (Culture & Foreign Language Advisor) on board . . . will contact the ACFLMO (Army Culture & Foreign Language Management Office) immediately for assistance in hiring a CFLA” (Dempsey, 2010). This author is listed as the Point of Contact, regarding who is to be contacted for follow-up information about the directive in that memo.

General Dempsey soon after advanced to the position of CSA (Chief of Staff of the Army). Within one year of this memo he was serving as Chairman, Joint Chiefs of Staff. Thus, the relevance of cultural concerns was clearly recognized at senior levels of the Army and DoD (Department of Defense).

The Wallace and Dempsey directives were echoed in the Army Learning Concept for 2015. The specific relevance of cultural emphasis is clearly stressed. “The Army operates with and among other cultures, engaging adaptive enemies where indigenous populations, varying cultures, divergent politics, and wholly different religions intersect. This requires developing Soldiers who understand that the context of the problem matters and that their understanding of the non-military world of foreign societies and cultures should be broadened. Soldiers and leaders need to learn general cultural skills that may be applied to any environment as well as just-in-time information that is specific to their area of operations. The Army culture and foreign language strategy requires both career development and pre-deployment training to achieve the culture and foreign language capabilities necessary to conduct full-spectrum operations” (Army Learning Concept for 2015, p. 11).

There was a recognized need to proactively leverage cross-cultural understanding in such a way that this knowledge can be harnessed and used as foundation for effective decision-making. The option, or status quo at that point, was to merely react to cross-cultural problems when they occurred. The Abu Graib prison abuses yesterday, burnt Qur’ans today, what problem is waiting to happen tomorrow? We are going to gain much more ground being on the cultural offensive than to continually find ourselves spontaneously responding to cultural problems & challenges and being on the cultural defensive whereby victory is seen to be merely protecting the posture we are presently in.

### **The Army Culture & Foreign Language Management Office**

Within this framework the Army Culture & Foreign Language Management Office (ACFLMO) was founded to build the Army Culture & Foreign Language Enterprise (ACFLE) in accordance with the Army Culture & Foreign Language Strategy (ACFLS). Four individuals were hired to address this task.

Captain (U.S. Navy, retired) Dave Ott was hired in the fall, 2009 to serve as Director of the ACLFMO. Dave, an Annapolis graduate, had been a naval aviator and went on to work various intelligence/targeting assignments. He is known to be gifted with entrepreneurial tasks within the DoD community and was brought in to navigate the DoD waters and “make things happen.” That he does.

Colonel (U.S. Army, retired) Eric Stanhagen was hired in the winter, 2010 as ACFLMO Deputy Director. Eric, a West Point graduate, had a distinguished career in Special Forces, has an acute understanding of the Army bureaucracy and exercises sound judgment regarding details supporting strategies and tactics for getting ACFLMO objectives accomplished. He was a “by name” hire by Dave Ott. They had worked closely together, in an operational setting, during their active duty years.

Captain (U.S. Navy, retired) Bruce (Rocky) Wilkinson was hired in fall, 2009 during the initial months of the ACFLMO standup. He had served the U.S. Navy as a career intelligence officer. Like Eric, he has an innate sense for macro-level DoD concerns, but also evidences a keen eye for details regarding specific practices and protocol concerns.

A common process regarding ACFLMO advancement is for Dave to have the initial inspiration of an idea, Eric provides insight regarding if it is realistic and how it might be approached and Rocky nails down the specifics of how to proceed insofar as how to move ahead and via what channels. Working with them, observing this process, is akin to watching a ballet. Each dancer with his part.

This author, Colonel Jim Schnell, Ph.D. (U.S. Air Force Reserve, retired), was hired in spring, 2010 as the Lead Social Scientist. He had 30 years service in the military intelligence community with the final 14 years as Assistant Air Attache to China. His background as a social science Ph.D., working in civilian universities, provides him with insights for recruiting CFLA candidates, vetting credentials, interviewing and the hiring process.

Central to the effective functioning of these four members of the ACFLMO is that there is a high level of expertise (all four have attained the rank equivalent of O-6/Colonel) and a climate of respect & trust that makes for productive working relationships. Dave Ott, as Director, can be credited for working to create and maintain this contextual backdrop for ACFLMO functioning.

The ACFLMO was originally situated in the G-2 (Intelligence) directorate of TRADOC in that it was observed to be the most appropriate domain to place the ACLMO function. It reported to the head of G-2, Maxie McFarland, via Dave Ott (the ACFLMO director). The ACFLMO staff and all CFLAs were hired on two year contracts with the allowance for renewable contracts beyond that.

### **The Culture & Foreign Language Advisor (CFLA) Enterprise**

The ACFLMO manages the CFLA enterprise via hiring of CFLAs and placement at the following locations: Maneuver CoE (Fort Benning, GA) , Infantry & Armor Schools (two positions filled by Drs. Ron Holt & Dr. Toni Fisher); Maneuver Support CoE (Fort Leonard Wood, MO), Engineer, Military Police, & Chemical Schools (one position initially filled by Dr. Tseggain Isaac and subsequently filled by Boshra El-Guindy); Intel CoE (Fort Huachuca, AZ), Intel School (one position that is covered by the TRADOC Culture Center); Aviation CoE (Fort Rucker), Aviation School (one position filled by Dr. Mandouh El-Nady);

Signal CoE (Fort Gordon, GA), Signal School; BCT/SSI CoE (Fort Jackson, SC), Basic Combat Training, Finance, Adjutant General Schools (one position filled by Dr. El-Rayah Osman); Sustainment CoE (Fort Lee, VA), Army Logistics University, Quartermaster, Transportation, & Ordnance Schools (two positions filled by Drs. Andrew Kosydar & Howard DeNike); Fires CoE (Fort Sill, OK), Artillery, Air Defense Artillery Schools (two positions filled by Drs. Daryl Liskey & Hassan Ahmed); AWC (Carlisle Barracks, PA), Army War College (one position filled by Dr. Adam Silverman); USASMA CoE (Fort Bliss, TX), Sergeants Major Academy (one position filled by Dr. Scott Wilson).

Since inception the CFLAs have been guided by a very basic directive used as a foundation to build from. That directive rests within the following statement. The mission of the Army Culture and Foreign Language Management Office (ACFLMO) is to manage the implementation of the Army Culture and Foreign Language Strategy (ACFLS). Fifteen Culture and Foreign Language Advisors (CFLAs) have been placed at the TRADOC (Training & Doctrine) Centers of Excellence (CoE). The CFLA function is to assist CoE leaders by working to infuse culturally oriented emphasis into CoE programming. Each CoE has unique areas of focus and, thus, the CFLA positions at each CoE are unique insofar as they reflect the goals of each particular CoE.

The CFLA selection process, as administered by the ACFLMO, is rigorous and involves thorough vetting to ensure top quality CFLAs, holding verifiable Ph.D.s, are placed at the CoEs. The only exception to the aforementioned hiring process involved the two CFLAs at Fort Leavenworth. These two CFLAs serving CGSC, ILE (Command & General Staff College) CoE (Fort Leavenworth, KS), Mr. Sameh Yousseff and Mr. Mahir Ibrahimov, were hired via other means that involved a different hiring mechanism.

CFLAs are hired for an initial two-year period and can typically be renewed for two year increments. Some of the CFLAs, such as professors who hold tenured faculty positions in a university, choose to participate for a two years and then return to their university (with the possibility of returning to the CFLA enterprise later). Others seek to remain in their CFLA positions via two year renewals. Thus, the CLFA Enterprise has balance between long and short term CFLAs.

A significant aspect of the vetting process, during the recruitment of CFLA candidates, focuses on ensuring that claims of academic credentials are legitimate. In civilian higher education, where such academic credentialing concerns are commonly dealt with, familiarity with this issue helps ferret out fraudulent claims in fairly short order. However, this author found that claims of academic credentials can easily go undetected in domains outside of higher education, such as government, because most people in such settings simply are not aware how easy it is to make a fraudulent credential claim and have it go undetected.

A grey area in that regard involves degrees from “diploma mills,” which equates with paying a fee and getting a Ph.D. in return after writing a report (or not even that) and receiving the necessary course credits for “life experiences.” Such Ph.D. degrees are a sham, clear and simple, but this author has observed first hand how such claims can go unchallenged. A simple way to ensure legitimate claims, that is the universal routine practice in civilian higher education, is to require that a certified copy of the Ph.D. transcript be sent to the hiring organization directly from the university that has granted the degree. Then the quality of such institutions can be gauged to ensure legitimacy. That approach was used by this author in his role as Lead Social Scientist. All CFLAs hired by this office followed this procedure and Ph.D. transcripts for such CFLAs are kept on file in the ACFLMO.

The CFLA Enterprise functions very much like a university faculty. Each CoE benefits from the regional area expertise of the CFLA assigned to that CoE but each CoE also benefits from

the regional expertise areas of all the CFLAs in the Enterprise. So the CFLA assigned to Fort Leonard Wood, who has Middle-East area expertise, can call on the CFLA from Fort Gordon if Central Asia expertise is needed. Thus each CoE can benefit from the expertise of their locally assigned CFLA(s) and the expertise of all the CFLAs posted at other CoEs.

### **The CFLA Enterprise as Flat & Agile Organizational Entity**

The CFLA Enterprise is flat, agile and can change directions in short order. It places CFLAs with each CoE/school to create a flat, highly communicative Enterprise that is rich in geographic, academic and operational diversity and assists Commandants in providing the best possible culture & foreign language offerings within Program of Instruction (POI) parameters. The CFLA Enterprise garners efficiencies, eliminates redundancies and builds coherence of effort.

It contrasts the larger DoD bureaucratic system within which it is positioned and serves. The larger DoD bureaucracy functions for the most part via position descriptions and vividly clear expectations but also does allow for innovation. The CFLA enterprise, in contrast, is driven primarily by innovative applications while giving secondary emphasis to more standardized expectations.

The relevance of this unique enterprise approach, within the larger DoD system, cannot be overstated. For instance, the emphasis on culture is about education versus training. The CFLA enterprise is predicated on that realization. It is a given. Whereas the larger Army is much more about training versus education. Training is much easier to design, implement and assess. Education is more vague and has more levels of abstraction involved. The CFLA Enterprise recognizes these challenges and operates from a better position to engage such challenges given the flat and agile nature of the structure from which it operates.

An Enterprise is understood to be a collection of people, processes and technology within organizational structures that have a set of purposes in common. It generally refers to people and organizational components that exist in many organizations and function as a network. This is commonly labeled as Network Centric Operations (Ott, 2010).

This kind of process and content often run counter to the instinctual nature of functioning that can evolve over time when Army members (Soldier and civilian) become used to defining their work landscape in terms of vivid blacks and whites rather than more abstract shades of grey. They are not to be faulted for having such an orientation. The system within which they work prescribes, and rewards, such mindsets. This is much more about the bureaucratic nature of organizations than it is about the individuals or being that it is the military.

As such there are organizational anti-bodies that innately reject the mission and structure of the CFLA Enterprise approach. This is where the multi-faceted talents of the ACFLMO have vividly come into play to protect the enterprise and work to carve out niches where the CFLA Enterprise can not only survive but thrive. The collective understanding of Dave Ott, Eric Stanhagen and Rocky Wilkinson has been key in that regard.

Each CFLA has a regional area of expertise (East Asia, Middle East, Africa etc.) and other areas of expertise. For instance, some CFLAs have significant backgrounds with survey methods and qualitative methodologies. There are frequent exchanges of information among the CFLAs via e-mail, telephone, CFLA teleconferences and CFLA conferences. Most common are e-mail exchanges whereby all the CFLAs receive a message sent by one of the other CFLAs or member of the ACFLMO and this typically begins a dialog that can result in exchanges that go on over a period of days. Sometimes specific CFLAs have a specific interest in some facet of a topic and can arrange to discuss an issue via phone.

Once a month, on the third Tuesday of each month at 1-2:30 p.m. (Eastern Time), CFLAs call in to the ACFLMO phone system to participate in a CFLA teleconference that involve guidance from the ACFLMO, discussion of various topics of concern and general announcements affecting the enterprise. Less common are the CFLA conferences where CFLAs meet as a group with the ACFLMO for a few days to discuss issues of concern that can benefit from extensive discussion.

The CFLA enterprise embraces a high degree of academic freedom for the individual CFLAs. That is, CFLAs enjoy considerable freedom to operate independently so as to generate an abundance of ideas. This approach works very well with brainstorming and prompts a wide range of considerations regarding problem solving and how to address challenges. After everybody conveys input on an issue, if there is not a consensus, then the ACFLMO offers a ruling that typically involves some sort of compromise. This approach usually allows us to generate quality ideas and reinforce respect for diversity of thought.

Beyond the CFLA Enterprise, the CFLAs have periodic exchanges with entities who provide degrees of support for our common efforts and concerns. The Cultural Knowledge Consortium (CKC), which includes a wide range of Army people and organizations that focus on culture, provides a forum for exchange on a variety of topics affecting cultural understanding. Similarly, Army Knowledge Online (AKO) provides a website where Army personnel can post information and seek information about a variety of topics, including culture.

### **The Army Culture & Foreign Language Strategy**

The Army Culture and Foreign Language Strategy (ACFLS) has served as the functioning framework for the CFLA Enterprise. It was created in December, 2009 and has guided much of the development of the CFLA program. The overall goal is to “build and sustain an Army with the right blend of culture and foreign language capabilities to facilitate full spectrum operations, now and in the future” (Army Posture Statement, 2011). “The ACFLS goal is to establish a baseline of culture & foreign language capabilities for all leaders and Soldiers to support the accomplishment of unit missions . . . . The resulting force will have the ability to effectively conduct operations with and among other cultures” (Smith, 2012, p. 3).

Use of such a strategy as a guide is not common in such contexts but it has been used to ensure the CFLA Enterprise has the freedom to identify the most pressing issues and speculate on how these issues can best be addressed. To be constrained by too many details, that may lack in relevance, would only fog the environment CFLAs are working in. Thus, the strategy was designed to be a guide, not a directive. It was intended to undergo significant revision. This kind of flexibility has been key to the success of the CFLA Enterprise.

The ACFLS seeks to fix the “gap” in culture and foreign language capability by focusing on the capabilities we have versus what we need. It seeks to integrate efforts across the Army. It is nested in the Army Leader Development Program (ALDP) and defines requirements by cohort for culture and foreign language within the general purpose force (GPF). The overall goal being to build and sustain an Army with the right blend of culture and foreign language capabilities to facilitate unified land operations.

It is worth noting that the Army’s Leader Development Strategy prescribes that the future security environment will require leaders who *understand* the context of the factors influencing the military situation, *act* within that understanding, continually *assess and adapt* those actions based on the interactions and circumstances of the enemy and environment,

*consolidate* tactical and operational opportunities into strategic aims, and be able to effectively *transition* from one form of operation to another. As leaders and Soldiers support full spectrum operations, challenges in how we conduct military operations will require agility and innovation as new adaptive threats that employ a mix of new and old strategies and technologies emerge (TRADOC, 2011, p. 1).

Without a coherent strategy we have a scenario where there are many oars rowing but no movement. The strategy provides a framework preparing individuals & units, Soldiers & leaders and it develops experts as well as the general force. It does this via two paths, career development (life-long learning) and pre-deployment, that move toward the desired end state of building and sustaining an Army with the right blend of culture & foreign language capabilities to facilitate full spectrum operations.

Thus, the overarching goal can be recognized as developing and maintaining expeditionary forces that are led by Soldiers who are ready to deploy and operate effectively anywhere in the world across the full spectrum of conflict. This will require leaders who have sufficient cross-cultural, regional and foreign language competencies to enable the successful execution of military operations...not only an understanding of the culture and language in a particular area, but an understanding of the implications these considerations have on how operations are conducted. To achieve this goal, leaders and Soldiers must increase their cultural knowledge through operational experience, self-development, or as a learning opportunity during their professional military education. Within TRADOC, this will require schools and centers to develop, integrate and deliver cross-cultural education within their respective programs of instruction (TRADOC, 2011, p. 2)

### **Cross-Culture Competence as Primary Theoretical Construct**

The primary theoretical consideration in the life of the CFLA Enterprise focuses on cross-cultural competence (3C). It is directly, and indirectly, related to much of what we do on a daily basis. “Cross-cultural competence is based on a set of knowledge, skills and attributes (KSAs) developed through education, training and experience that provide the ability to operate effectively in any culturally complex environment” (Department of Defense, 2010, p. 1).

Cross-cultural competence is recognized as a force multiplier that can significantly enhance operations. It can develop over time through experience, but can also be accelerated by principled learning methods. Cross-cultural competence enables negotiation and persuasion; mediation and conflict resolution; leadership and influence; cultural evaluation, synthesis, and predictive analysis during staff planning; and other abilities that pertain to a specific geographic area. Additional characteristics are:

- 1) Cross-cultural competence provides awareness of culture and of one’s own cultural context, general cross-cultural schema and culture-analytic models, and an increasingly complex understanding of the impact of culture on military planning and operations (knowledge).
- 2) Critical aspects of cross-cultural competence are interpersonal and communication skills, flexibility in seeing different cultural frames and perspectives, and the ability to regulate one’s own reactions (skills).
- 3) Necessary ingredients of cross-cultural competence are non-ethnocentric attitudes,

motivation to learn about culture and to update one's knowledge base as new information is encountered and empathy grows (attributes). (TRADOC, 2011, p. 2)

Focus on cross-cultural competence can be recognized in various areas of the defense establishment and has been building over time. It is evidenced in the 2004 National Military Strategy, underscored in the 2008 National Defense Strategy and reiterated in the 2010 National Security Strategy. The 2006 National Security Strategy exemplifies such emphasis in that there is a stated need for “actively engaging foreign audiences, expanding educational opportunities for Americans to learn about foreign languages and cultures and for foreign students and scholars to study in the United States” (National Security Strategy, 2006, p. 45). Emphasis on cross-cultural skills has received attention at the highest levels of the U.S. government. In March 2009, Defense Secretary Robert Gates conveyed “Global competence, which consists of foreign language skills and cross-cultural communication, has now become a national critical competency . . . . Just about every military member of our Armed Forces will serve in a foreign country at some point in their military careers. . . .” (Department of Defense, 2010, p. 9).

Similarly, Ms. Gail McGinn, Deputy Under Secretary of Defense (Plans) followed up in June, 2009 with the assertion that has resonated throughout DoD (Department of Defense). “Cross-cultural competence is a force multiplier, allowing members of the Total Force who have not received in-depth training to operate in a multi-cultural environment . . . . Most importantly, 3C enables all members of the Total Force to adapt to a multi-cultural force, to multi-cultural conditions, and to multi-cultural operating environments” (Department of Defense, 2009, p. 4).

In most basic terms cross-cultural competence can be understood through the “Framework of 3C Core Competencies & 3C Enablers.” They stress Thinking Factors--applying cultural knowledge, organizational awareness & cultural perspective taking; Connecting Factors--communication, interpersonal skills & cultural adaptability; Resilience Factors--focusing on the self, emotion & cognition; and Engagement Factors--learning & interaction (Defense Language Office, 2011, p. 4).

The “Framework of 3C Core Competencies & 3C Enablers” serve as foundation for seven “Core Competency Learning Recommendations” (Defense Language Office, 2011, pp. 7-16). These recommendations are well grounded in the academic literature and this grounding reinforces the legitimacy of the Framework.

Recommendation One: Applying Cultural Knowledge stresses considerations such as culture, cross-cultural communication, common cultural processes, cultural evolution, multiple layers of cultures (McDonald et al., 2008) and common cultural behaviors/systems & structures/beliefs & values (Selmeski, 2009). This also includes emphasis on operational culture (NAVMC 3500.65, 2009), environmental cues (Wisecarver et al., 2010), history/politics/religious factors (Ross et al., 2010), geographical features (McDonald et al., 2008) and current social/ethnic/language features (Russell et al., 1995).

Recommendation Two: Organizational Awareness promotes concern with organizational mission, social systems, policies and requirements (Wisecarver, 2010). These areas are accented with focus on military cultures (McDonald, 2010) and cross-cultural teamwork skills (Sutton et al., 2006; Tuckman, 1965).

Recommendation Three: Cultural Perspective Taking Skills include conceptual basics, observing & interpreting skills and skills with navigating point of view of others. Conceptual

basics relate to the role of cultural roots, cultural models & attitude formation (Russell et al., 1995) along with cultural assumptions, values & biases (Wisecarver et al., 2010). Observing & interpreting skills deals with situational cues (Abbe, 2007; McCloskey et al., 2009), perceptual cues & cultural context (Wisecarver et al., 2010) and tactical, operational & strategic planning (Ross et al., 2010). Skills with navigating point of view of others address cultural assumptions (Abbe et al., 2007), self perception processes (McDonald et al., 2008), sensitivity to diversity (Hardison et al., 2009) and cultural values & assumptions (Wisecarver et al., 2010).

Recommendation Four: Communication Skills involves nonverbal and verbal concepts & skills. The nonverbal frameworks stress acceptable behavior considerations (Wisecarver et al., 2010), relevance of nonverbal behaviors (NAVMC 3500.65, 2009), typical nonverbal cues (McDonald et al., 2008) and acceptable display rules (Russell et al., 1995). The verbal frameworks focus on survival and tactical language skills (NAVMC 3500.65, 2009) and audience expectations (Wisecarver et al., 2010). Similarly, the role of listening skills and intercultural perspectives are acknowledged (INCA, 2004).

Recommendation Five: Interpersonal Skills primarily addresses cross-cultural contexts (Mendenhall et al., 2008), conflict oriented relations (Hardison et al., 2009) and persuasive techniques (Russell et al., 1995). These primary concerns are reinforced via secondary concerns of rapport (Mendenhall et al., 2008), language barriers (Wisecarver et al., 2010) and emotional/psychological needs (Mendenhall et al., 2008).

Recommendation Six: Cultural Adaptability deals with adapting behavior in other cultural contexts (Abbe et al., 2007) and behavioral adjustment considerations (Wisecarver et al., 2010). The relevance of these variables are enhanced via understanding of situational integration (Ross et al., 2010), self monitoring efforts (Mendenhall et al., 2008) and situational interpretation (Ross et al., 2010).

Recommendation Seven: 3C Core Enablers outline a wide range of suggested learning concerns. These areas of concern focus on critical thinking & perspective taking (Matsumoto et al., 2007), stress exposure (Driskell & Johnston, 1998) and emotion management (Matsumoto et al., 2001). Supplementary support skill areas include self-correction (Smith-Jentsch et al., 1998), and cultural adaptability (Sutton et al., 2006).

A related major component of the culture development program is regional competence. Regional competence is a set of knowledge, skills, and attributes related to a particular country, region, organization, or social group, which enables effective adaptation to that specific culture. Additional characteristics:

- 1) Awareness of the historical, political, cultural (including linguistic and religious), sociological (including demographic), economic, and geographic dimensions of a foreign country, global region, or other specific culture.
- 2) Enables negotiation and persuasion; mediation and conflict resolution; leadership and influence; cultural evaluation, synthesis, and predictive analysis during staff planning; and many other abilities that pertain to a specific area of operations.
- 3) Ability to adopt perspectives common to that culture; ability to regulate one's own behavior, communication, and emotional expression to match cultural norms where appropriate. Includes positive attitudes toward the population and motivation to learn about the culture, to include how they make decisions. (TRADOC, 2011, pp. 2-3)

### **Duties of the Culture & Foreign Language Advisor**

The primary roles of the CFLA are to infuse cultural awareness into the CoE curriculum where he/she serves, advise the CoE how to meet the cultural requirements set forth by the OPOD (Operations Order), teach courses, provide lectures within sections of courses, initiate interest with culturally oriented programming and participate with special projects that are brought to CFLA attention by the ACFLMO and their CoE. An example of the latter occurred when AFRICOM (African Command) requested CFLA assistance with U.S. troop preparations for duty in Africa. Four CFLAs have substantial expertise with the African continent and were tasked to assist with this undertaking. The ACFLMO is periodically contacted about these types of special projects and draws from the expertise of the CFLA enterprise to address such needs as they arise.

Each CoE is unique and has needs that are unique to that location so each CFLA is encouraged to address what is specifically needed at his/her CoE rather than be being bound by minute details of a standard job description. However, at the same time, there are common ground considerations that are shared across the CFLA Enterprise. The following list of such considerations is not meant to be seen as requirements but, rather, as areas the CFLA can consider stressing.

Thus, a fully developed Army Culture & Foreign Language Program can be understood with regard to the following:

- 1) Have a clear Culture & Foreign Language strategic document that acknowledges its particular situation and mission.
- 2) Have a clear mandate from the CG, be nested in the Staff and appropriate Task Organization with appropriate mission and vision statements.
- 3) The CFLA should work as a colleague with various directorates and libraries across the organization.
- 4) The CFLA should act as a liaison to other COEs and Army organizations as well as the cultural centers of other military services.
- 5) Have a well developed plan that seeks to infuse cultural awareness in relevant areas of the curriculum.
- 6) Have a website with easy access to culture and foreign language resources.
- 7) Maintain a library that carries culture & foreign language resources and related materials.
- 8) Maintain good media relations for high visibility and reputation.
- 9) Sponsor language programs, culture programs and guest lectures on the COE installation.
- 10) Have training and education available to DoD (Department of Defense) civilians.
- 11) Support pre-deployment training.
- 12) Encourage lifelong learning initiatives.
- 13) Ensure appropriate budgeting plans are in place to support the work of the CFLA and related programming.
- 14) Constantly evaluate trends in the world-wide operating environment.
- 15) Engage in active outreach with other CFLAs at various COEs as a means to improve cultural programming.

Assessment of CFLA functioning, with regard to contract renewal, is addressed primarily by the CoE being served based on their view of how well they are being served by the CFLA. It

is addressed secondarily by the ACFLMO insofar as gauging how well the CFLA maintains linkage with the CFLA enterprise mission and practices. A key venue for the ACFLMO to do that is via the CFLA portfolio that is to be prepared by the CFLA.

CFLAs function with a high degree of autonomy. Most DoD positions are organized in such a way that the employee has a job description which is used to evaluate performance. That is, performance is measured against the standard of the position description. The CFLA existence is more abstract in that the needs of the CFLA position are unique to that location and the needs are constantly changing. The CFLA has a high degree of freedom to do whatever he/she thinks should be done. A possible shortcoming with this scenario is that there can be a lack of accountability and mismanagement, with regard to CFLA functioning, in comparison to more standard DoD positions.

### **The CFLA Enterprise in Relation to Army Leader Development**

A significant circumstance that frames the work of the CFLA is that cultural emphasis exists within the larger context of leader development concerns. As such, cross-cultural education should build on the foundation of an individual's existing leader attributes which in turn reinforces the core leader competencies of leading others, developing oneself and achieving results:

- 1) *Character.* A leader of character internalizes the Army Values, lives by our Professional Military Ethic, reflects the Warrior Ethos and displays empathy towards Soldiers, families and those people affected by the unit's actions. Competence places an individual in position to lead – character makes him or her an effective leader.
- 2) *Presence.* A leader of presence has credibility, exudes confidence and builds trust. Presence is conveyed through actions, appearance, demeanor and words.
- 3) *Intellect.* A leader of intellect has the conceptual capability to understand complex situations, determine what needs to be done and interact with others to get it done. Leaders must have the ability to reason, to think critically and creatively, to anticipate consequences and to solve problems. (TRADOC, 2011, p. 4)

### **The Way Forward**

The CFLA Enterprise, conceptually and thematically, represents innovative initiative with regard to the content it is addressing and the format it is using to do so. It portrays how the military can learn from the past, understand the present and exercise vision with speculation about the future. The CFLA enterprise exemplifies approaches that manifest competency with all three concerns.

The relevance of cultural understanding has been stressed since the beginnings of organized society. The lessons seem to be relearned from generation to generation via recognition of their relevance. The efforts of the CFLA Enterprise seek to approach such cultural phenomena in a manner that will have lasting impact and provide a solid foundation for development of applicable models for enhancement of cultural understanding.

Toward that end, this report is intended to record a point on the CFLA Enterprise timeline so that weaknesses can be diminished and strengths can be capitalized on. The path to preeminence is typically littered with outdated assumptions and rejected theories. This report

provides a beginning baseline from which the effectiveness of the CFLA Enterprise can be measured and gains can be gauged.

On a larger scale, findings from this report convey how the Enterprise model can be used with varied types of initiatives. The idea of creating a flat, agile enterprise within a deep, entrenched bureaucracy challenges standard inside-the-box assumptions but, at times, can produce outside-of-the box results that are beneficial and visionary in scope. The report serves as a contribution to that fund of knowledge and intention.

## References

- Abbe, A., Gulick, L. M. V., & Herman, J. L. , 2007. *Cross-Cultural Competence in Army Leaders: A Conceptual and Empirical Foundation*\_(ARI Study Report 2008-01). Arlington, VA: U. S. Army Research Institute for the Behavioral and Social Sciences.
- Army Posture Statement, 2011.
- Defense Language Office, 2011. *A Framework for Cross-Cultural Competence and Learning Recommendations*. Arlington, Virginia: Defense Language Office.
- Department of Defense, 2007. *Human Terrain Team Preliminary Assessment*.
- Department of Defense, 2010. *Cross-Cultural Competence Roadmap*
- Dempsey, Martin. 2010. *Memorandum from U.S. Army TRADOC (Training & Doctrine) Commanding General to CoE (Centers of Excellence) Commanding Generals/Commandants*. (22 September).
- Driskell, J.E. & Johnson, J.H. , 1998. "Stress Exposure Training." In J.A. Cannon-Bowers & E. Salas (Eds.), *Making Decisions Under Stress: Implications for Individual and Team Training*. Washington, D.C.: American Psychological Association.
- Hardison, C.M., Sims, C.S., Fargabam A., Villamizar, A., Mundell, B. & Howe, P. , 2009 *Cross-Cultural Skills for Deployed Air Force Personnel: Defining Cross-Cultural Performance*. Santa Monica, CA: Rand Corporation.
- Intercultural Competence Assessment (INCA) Project*, 2004. sponsored by Leonardo da Vinci II. London, UK: CILT - National Centre for Languages.
- Matsumoto, D., LeRoux, J.A., Roblesa, Y., & Campos, G. 2007 The Intercultural Adjustment Potential Scale (ICAPS) Predicts Adjustment Above and Beyond Personality and General Intelligence. *International Journal of Intercultural Relations*, 31(6), 747-759.
- Matsumoto, D., LeRoux, J., Ratzlaff, C., Tatani, H., Uchida, H., Kim, C., & Araki, S. , 2001. Development and Validation of a Measure of Intercultural Adjustment Potential in Japanese Sojourners: The Intercultural Adjustment Potential Scale (ICAPS). *International Journal of Intercultural Relations*, 25, 483-510.
- McCloskey, M.J., Grandjean, A., & Behymer, K.J., 2009. *Assessing the Development of Cross-Cultural Competence in Soldiers*. Arlington, VA: U. S. Army Research Institute for the Behavioral and Social Sciences.
- McDonald, D. P., McGuire, G., Johnston, J., Selmeski, B., & Abbe, A., 2008 *Developing and Managing Cross-Cultural Competency within the Department of Defense: Recommendations for Learning and Assessment*. Defense Equal Opportunity Management Institute (DEOMI/J-9). Patrick Air Force Base, FL,

Mendenhall, M.E., Stevens, M.J., Bird, A., & Oddou, G.R., 2008. *Specification of the Content Domain of the Global Competencies Inventory (GCI)*. Chesterfield, MO: The Kozai Group Inc.

*National Security Strategy of the United States*, March 2006.

NAVMC 3500.65 *Marine Corps Operational Culture, Language Training and Readiness Manual (Short Title: Culture T&R Manual)*, 2009.

Ott, D.T. 2010. *Army Culture and Foreign Language Management Office Information Brief*.

Ricks, T.E. 2006. *Fiasco: The American Military Adventure in Iraq*. New York: Penguin Books, 2006.

Ross, K.G., MacNulty, C., Bencaz, N.A., Thornson, C.A., & Johnston, J. 2010 *A Framework for Cross-Cultural Competence (3C) Learning Outcomes*. Defense Equal Opportunity Management Institute (DEOMI/J-9), Patrick Air Force Base, FL.

Russell, T.L., Crafts, J.L., & Brooks, J.E., 1995. *Intercultural Communication Requirements for Special Forces Teams*. U.S. Army Research Institute for the Behavioral and Social Sciences (Report #1683)

Selmeski, B. R. , 2009. *Expeditionary Airman Field Guide: Iraq*. Air Force Culture & Language Center

Smith-Jentsch, K.A., Zeisig, R.L., Acton, B., & McPherson, J.A. , 1998. Team Dimensional Training: A Strategy for Guided Team Self-Correction” In J.A. Cannon-Bowers & E. Salas (Eds.), *Making Decisions Under Stress: Implications for Individual and Team Training*. Washington, D.C.: American Psychological Association,

Smith, S. , 2012 “Army Culture and Foreign Language Program,” *Military Intelligence* (Volume 38, No. 1),

Sutton, J.L., Pierce, L.G., Burke, C.S., & Salas, E., 2006. Understanding Adaptability: A Prerequisite for Effective Performance within Complex Environments. *Advances in Human Performance and Cognitive Engineering Research*, 6, 143-173.

TRADOC Leader Development and Education (LD&E) Culture and Foreign Language Guidance FY ‘12 Planning, 2011.

Tuckman, B. 1965. Developmental Sequence in Small Groups. *Psychological Bulletin*, 63, 384-399.

*U.S. Army Learning Concept for 2015*, 20 January 2011.

Wallace, William. , 2008. *Memorandum from U.S. Army TRADOC (Training & Doctrine) Commanding General to CoE (Centers of Excellence) Commanding Generals/Commandants* (4 December).

Wisecarver, M.M., Ferro, G., & Hope, T., 2010. *Proposed Regional Proficiency Competency Model*. Arlington, VA: Defense Language Office.

# Dual Identity in Interethnic Context

KOME – An International Journal of Pure  
Communication Inquiry  
Volume 2 Issue 1 p. 28-36  
© The Author(s) 2014  
Reprints and Permission:  
kome@komejournal.com  
Published by the Hungarian Communication  
Studies Association

**Barbara Sólyom**

Corvinus University of Budapest, Doctoral School of Social Communication, Hungary

**Abstract:** The field of social psychology, over the past few years, has created a new term to describe threats to collective identity called social identity threat. This study sets out to present how social identity threat may arise between different ethnic groups, describes its conditions and determining factors, possible responses and forms of reaction to such dangers; furthermore, it also covers factors which decide what self-defense strategy one may choose. Finally, the possible outcomes and consequences are examined. The article discusses the phenomenon of social identity threat using empirics of theoretical and international research applied to the coexistence of ethnic Germans and Hungarians in a village in Hungary. Exploring the life of the settlement is part of a broader empirical research.

**Keywords:** ethnic minorities, interethnic relationships, group identity, stereotypes, prejudice, social identity threat

## Introduction

In order to accurately describe the notion of social identity threat, one must first define the term of *collective identity* and its evolution and importance has to be briefly summarized as well. Aspects nurtured by emotions and knowledge applied or related to our group forms an essential part of ourselves as, according to the social identity theory, one's identity originates from one's personal group. These associations determine in what ways we differ from or are similar to other members. This means that our personal identity includes the mentality, worldview and value system of our group and since we are members, our own identity simultaneously influences and determines norms and beliefs within the group. Personal and collective identities thus mutually determine each other and this relationship is apparent in the case of stereotypes and prejudice as well; personal preconceptions and generalizations affect those of the group and vice versa.

*Address for Correspondence:* Barbara Sólyom, email: barbara.solyom[at]uni-corvinus.hu

Article *received* on the 11th March, 2013. Article *accepted* on the 21th April, 2013

*Conflict of Interest:* The author declares no conflict of interest.

Collective identity, that is the feeling of belonging to a group, *is defined by two factors and from two directions*: one is that we define ourselves as group members and the second is that other persons perceive us as belonging to a certain group.

Numerous studies in the field of psychology, sociology and social psychology confirm that the significance of collective identity stems from the fact that we constantly evaluate our group higher and place it above other groups based on aspects important to us. Collective identity is essential for a member as it is the primary source of one's self-esteem. (Turner & Oakes 1986).

### **Threats to nationality and ethnic identity**

Nationality and ethnic identity are part of social identity. They mainly serve to help individuals place themselves between various ethnic groups by using the dimensions of familiar and foreign. In case of the ethnic German community presented in the article, we may define ethnic identity as follows (Bindorffer – Sólyom 2007): feeling of attachment and self-identification of an individual to a group to which that person was born into, and where said individual acquires a set of knowledge related to ethnicity which will be the basis of comparison later on. In this knowledge system we find the common awareness of origin, the cultural repertoire, traditions and values determining the similarity of habit, religion and the practice of constructing and operating certain survival strategies; in other words, all that ensures identification and separation.

Identity threat is related to the phenomenon called stereotype threat (Steele and Aronson 1995). Steele and Aronson (1995) were the first to perform experiments demonstrating that stereotype threat can undermine intellectual performance in academic context. The results showed that performance was poorer only among those African-Americans whose racial identity was made salient prior to testing. These studies established the existence of stereotype threat and provided evidence that stereotypes suggesting poor performance, when made noticeable in a context involving the stereotypical ability, can disrupt performance, may produce doubt about one's abilities, and cause an individual to dissociate from one's ethnic group. This effect was termed *stereotype threat*. More than 300 published papers show the effects of stereotype threat on performance in a variety of domains.

*Social identity threat* (Vorauer 2003; Siklaci 2010; Daróczy 2011) may be defined as a hazard to collective identity. We are worried that others may judge us based on stereotypes applied to the group we belong to or that our behavior reinforces these stereotypes. This basically stems from meta-stereotypes: what stereotypes are used regarding the group according to its own individual member. These meta-stereotypes may be the source of social identity threat. *They are particularly visible in case of interactions between minorities, notably ethnic groups.* For example, the characteristics of unreliability, athleticism, exceptional aggressiveness, laziness are among meta-stereotypes of African-Americans meaning this is what they expect other Americans will see them as in case of interaction.

Threats to identity may appear as a result of various factors. These may include a visible difference in appearance or being easily able to classify one as member of a certain group. In such situations, an individual may “rightfully” consider the possibility that other persons belonging to different groups will define and evaluate him/her based on stereotypes and as someone who is member of a particular group. Aside from appearance, threats to identity may also be related to differences in social status.

Meta-stereotypes originating from interactions between minority ethnic groups do not necessarily cause social identity threat. The level of sense of fear is determined by how and to

what extent group members perceive stereotypes being applied against them. At this point, the role of attitudes should also be mentioned (Vorauer-Kumhyr 2001): less prejudiced individuals will feel less threatened by meta-stereotypes compared to those with serious preconceptions since the former believe that members of other groups will not apply these stereotypes against them. Another important factor is whether a fellow group member or someone belonging to another group is present in the given situation and what is his/her behavior (Vorauer 2003). In an experiment, persons with less prepossessions thought that if a member of another group is present and is surrounded by his peers, that group member will have a much more negative view towards the individual, compared to a scenario in which s/he were evaluating the situation alone. However, if we consider the opinion of an individual with many prejudices, a member of an external group will see the person less negatively if his/her peers are present as compared to an evaluation when s/he is alone. This means that the combination of individual attitudes and a social context determines how members of another group view the members of the in-group, and to what extent various ethnic groups experience social identity threat during interaction.

Let us look at the phenomenon of social identity threat using the relationship between the Hungarian majority and the German minority. In a study conducted in an ethnic German village of Pest county, Györgyi Bindorffer (Bindorffer 2001) considered the issue of interethnic relations as well. In a research of my own (Sólyom 2004), I also found features of majority-minority relations and manifestations at an intergroup level. I observed that the ethnic German population examined has a dual identity. They feel, live and define themselves both ethnic German and Hungarian simultaneously. Over the decades, they managed to acquire the most essential, most necessary knowledge in order to live securely, without any threats, and to participate in communication with the Hungarian majority as a survival strategy. Ethnic Germans adopted elements which are acceptable, useful and easy to integrate and which comply with a certain set of requirements; they are willing to acquire only as much as a dual identity, and are opposed to full homogeneity, assimilation and surrender. Members of the ethnic German community also develop, define and apply their own negative stereotypes towards the majority and have their prejudices operative. Nevertheless, reactions given to social identity threat do not necessarily follow the group pattern in every situation and in case of all members. Possible responses include full assimilation, detachment from the minority group, surrender, or departure from the group. Compromise as a solution also means dual identity. Dual identity thus is a certain response to factors, phenomena, tendencies that may threaten ethnic German identity and helps not only with self-preservation but also reduces inter-group conflicts. Such a duality means that when ethnic Germans identify themselves as Hungarians, negative stereotypes and attitudes towards Hungarians become less condemnatory, less of an insult and less exclusive and social identity threat becomes less significant. Experience gained from inter-ethnic relations and conclusions arrived at, emotional influences as well as assimilation affect and determine relations of the two ethnic groups in an opposite direction.

### **Responses to social identity threats**

Ethnic groups respond to social identity threat in multiple ways, and interaction between different groups may also take several forms (Síklaki 2010). One possibility is avoiding any contact between different groups, or escaping from these. This means – physically, mentally – we prefer not to interact with another group in order to protect our self-esteem. For instance, before the Second World War, the local elite in the ethnic German settlement (wealthy peasants and intellectuals) avoided interactions with local stone miners. They lived, spent their free time in different parts of the village, they frequented other people and they

did not allow their children to marry with those outside their group. They were proud of their social status and did everything in order to keep their positions and wealth. Another possible way to defend our self-esteem and positive image of ourselves is rejecting the views of other group(s). This of course is the case if our self-esteem is threatened – for example, when we receive negative feedback on our level of intellect -, we have an increased need for such a mechanism and prejudice becomes even stronger towards group members to which we apply stereotypes. This is due to the fact that we tend to evaluate people to whom we apply stereotypes more negatively and criticize them more profoundly. If our self-esteem is endangered, this process is further reinforced. If we have a chance to denigrate a member of the group to which we have attached stereotypes, we may significantly improve our self-esteem. Thus prejudice in this case has a reinforcing, an empowering effect. Such forms of defense have been used in ethnic German-Hungarian interactions, when the minority felt that stereotypes attached to them may be negative, e.g. ethnic German penny pinching, the importance attached to perceptions and superficialities.

Another possible form of “self-defense” may be to simply ignore the threat, not to fight it and to attempt to strengthen another aspect of our personality, thus highlighting and supporting our generally positive view of ourselves. This process may also be of prejudiced nature. However, if our self-esteem is not damaged, is not threatened or something previously has improved it, we do not need the aid of stereotypes and we do not reject other groups (Smith-Mackie 2001).

A third solution to avoid social identity threat is coordinating behavior during social interaction. People belonging to the majority or an ethnic minority may also respond to threats against their identity by modifying their behavior in order to ensure a good impression in the eyes of their partners. This means they change their behavior in order to avoid confirming an already existing stereotype and they harmonize it with stereotype expectations applied to the group they belong to. The ethnic German community is again an adequate example against whom a stereotype is that they work really hard, they save a lot, their first and foremost objective is increasing wealth and thus they are incapable of enjoying life due to the lot of work, the ascetic attitude and puritan lifestyle. They indeed live like this but they are proud of their mentality. They never deny these features, they never try to give an explanation, and instead they accept and are proud of these thereby reinforcing their self-esteem, identity while they also adhere to an external group’s precognition about them.

„Everybody, always, in all ways possible, had to increase wealth. This was an obligation, even if it meant sacrificing individual happiness. As they said: wealth marries wealth” – said one of my interviewees, a native ethnic German woman in her nineties when we were discussing what influenced the possibility of ethnic German-Hungarian mixed marriages.

The question ‘who opts for which strategy’ in order to avoid any dangers to his/her identity is determined by motivation, the efficiency of the self, power and status. Those who are motivated to ensure a better image and believe in success also believe that they have the capacities necessary to choose the strategy of controlling behavior. This behavior is thus a common feature of wealthy ethnic German families. However, those who lack determination and/or do not believe that they are capable of successfully influencing others’ perception of themselves, will instead rely on the other two strategies, namely avoidance or rejecting the external group’s views. Attitudes related to a given situation are also important. If tolerance dominates, people tend to strive for harmony, harmonic interactions and not rejecting opinions of other groups or criticizing these latter. Nevertheless, if they counter hostile attitude, they will become similar and fight takes place. If we examine selection of strategy from the viewpoints of status and power, we may conclude that persons of higher status are able to behave in a riskier way, choosing from a wider range of strategies which are of greater effects, compared to individuals who have a lower status. They express their feelings and

opinions more efficiently, they are more apt and their behavior during social interactions is much more diverse. They are more self-reliant, decisive, confident and tend to be “voices of groups” when compared to people of a lower status (Fiske 1993; Fiske 2006). During my research conducted in the ethnic German community, I have concluded that different strategies of defending one’s identity – in order to attain the goal – may also be mixed with each other. If relations of the ethnic Germans and Hungarians in the village are considered, we may see the following results (Bindorffer 2001; Sólyom 2004). Throughout history, ethnic Germans have repeatedly been assimilated by force; their positive ethnic features were looked down on. They were demanded to transpose values of the Hungarian majority as quick as possible while Hungarians did not take up any ethnic German mentality such as work culture of peasants, way of life, value system and way of thinking even after a considerable period of time. Ethnic Germans did everything to strengthen their identity and at the same time could not successfully oppose assimilation. Prior to the Second World War, the community of the village was rather closed which defined relations and communication in and between subgroups. A rigorous adherence to rules was typical: they established how one may and should behave with others, whom an individual may talk to, whom they can marry, or kids may or may not play with. They had a hard time accepting the arrival of outsiders. However, rules started to become more flexible over time due to certain historical and social events (e.g. the Second World War, the 1947 relocation, obligatory school and commute to work) following which the village became more open, acceptant but one can still sense that indigenous families allow outsiders to approach them only to a certain point.

Ethnic Germans classified themselves into different categories, groups. The scale ranged from acceptance to full rejection: majority Catholic Hungarians; local, native Hungarians of protestant faith who form a minority; Hungarians from neighboring Slovakia or the “settlers” (who arrived as a result of the exchange of population); people from nearby villages and communities (most of whom occupied empty houses of ethnic Germans after 1947). Ethnic Germans’ hostility was strongest (category of full rejection) towards Hungarians who moved into houses of ethnic German families who were relocated or forced to share houses with other minority families after their wealth has been taken away. The labels ‘Protestant’ and ‘settler’ became part of the category to be rejected reaching the same level as that before the Second World War, an ethnic German was not allowed to marry a settler and if so, he/she would have been shamed, looked down on, excommunicated and the relationship would have been ruined. Children of ethnic Germans could not play together with settlers’ kids, any form of contact was prohibited and the ethnic German community avoided any kind of interaction and maintenance of communication. Hungarians of Slovakian origin were regarded as a source of all problems, ethnic Germans transferred their scapegoat role onto them. The former were considered foreigners who took over their wealth, the dangerous, fear-inducing, and oppressive power to which only strongly negative content had been attached. Shared daily life, forcedly living together, having the same workplace, school, commute and Catholic religion softened tensions but older people continue to hold a grudge and to them the term “settler” still has negative connotations. These are thus not ethnic categories, but “simply” negative value judgments, prejudices. The local ethnic German community categorized Hungarian villagers based on denomination which was thus the ground for labeling. Protestant Hungarians, a minority in the village, were one group while Catholic Hungarians from outside the settlement were considered different. Catholic Hungarians were of the same faith as ethnic Germans so they were accepted more easily than Protestants, which was apparent in case of mixed marriages as well; they were more likely to approve of a marriage with a Hungarian Catholic. They were also unfriendly towards Hungarians of nearby settlements, people whom they considered lazy, messy, whom they looked down on but they did not fear. The German community never allowed Roma to settle in the village, anyone

who still stayed managed to do so as a result of a mixed marriage but only very few people. The ethnic German minority thus identified and kept trace of its enemies. Acceptance has slowly increased over time and the village is now more open, tolerant but still establishes categories. On the hill above the village, those who live in the area of vacation houses are foreigners to whom the outsider label has been attached, while permanent residents of the village who resettled here have been classified according to their behavior and attitude. Those who wanted to integrate have to take steps in order to be accepted e.g. have to attend Catholic church, have to send their children to the local kindergarten and school, should attend ethnic German balls and concerts, and if can play an instrument should participate in one of the local bands. Mixed marriages are becoming more and more common but non-ethnic German parties, although considered less of an outsider, will still never enjoy the same status.

The bond of marriage may present one of the greatest dangers to minority identity thus it is not surprising that this is where social identity threat is most apparent possibly even on the form of rejection:

“It was an ethnic German-Hungarian issue because Hungarians were unable to get used to the situation, they wanted to be involved in everything, parents did not allow certain relationships and prohibited them, but the young allowed themselves to be convinced” – said one of the interviewees, a local ethnic German man in his 80s.

„Family wanted to have a say in everything, the woman escaped, the relationship was ruined and the outsiders was picked on” – said a 60-some woman who moved into the village later.

„It was a Hungarian-German marriage, at first condemned, especially by those who considered themselves fully German, but it was later acknowledged. The situation further improved later on, the war loosened up many such rules, moral principles, forms of behavior, people mixed to a considerable extent, many have been in Russia and as mobility increased, so did life changed and many have seen a lot of things that were unheard of in the village, so ancient ‘remnants’ dissolved considerably later on” – said a man in his 80s who had also resettled in the village.

The question of identity is also raised within the ethnic German minority. Religion is a fundamental factor among local and non-local members of the German community. To be an ethnic German does not mean a common conscience, identification for all members in Hungary. Catholics belong to the “we” group while Lutherans are “them”. Aside from religion, different levels of assimilation, geographical fragmentation and different native language or dialect are also reasons why ethnic Germans do not constitute one single community. However, this is also changing as groups are getting gradually approaching each other.

„In the old times, there was a strong discrimination; a Protestant wanting to marry a Catholic had always caused huge problems. If they had already got married, it was accepted as it was a fact, unchangeable, people had to put up with it... This conflict has generally disappeared but to a slight extent may still be present on a personal level in case of certain individuals. Nowadays, it has again become important, but also due to the character of the two religions. A Protestant is a stubborn Calvinist, a persistent Calvinist” – says an 80 year old ethnic German interviewee who is a native to the village.

The relationship between ethnic Germans and other Germans outside Hungary is another identity-dimension. Ties of the local minority and Germans is becoming stronger as locals have direct experience with Germans living in Germany based partially on media as well as relatives, friends and personal experience. Following the repatriation in 1947, many relatives, friends who did not come back, those who returned and more and more intense relations between sister cities also fuel positive stereotypes of local ethnic Germans regarding other Germans, and they even want to become like them in certain fields of life. The multifocal relationship results in a considerable effort to teach and practice German to the extent that there is a German kindergarten and elementary school in the village, that is children learn and practice the language from a quite young age and they learn a German that is different from the one spoken in their homes, that differs from the dialect of the elders. Nevertheless, separation, emphasizing differences is still present: this is based on language, citizenship, patriotism and the bad, economy-oriented mentality of Germans according to the local minority. Given all these, the ethnic German minority is still situated closer to Hungarians than Germans of their home country, due to dual identity, everyday knowledge, living together and sharing a language.

### **Responses to social identity threat may have similar outcomes**

Avoiding interaction is the most harmful strategy when it comes to fighting stereotypes – this approach means no actual experience will be gained regarding the other group –shameing another group and rejecting its views will result in retaliation and there will never be understanding and acceptance between the two opposing sides. Chances of reducing prejudices may considerably vary. Evading a strongly judgmental person means the minority group protects itself from negative stereotypes. However, if one interacts with said person, we may experience a serious damage to our values. Meanwhile, avoiding a person with less precognitions means there is no actual chance to decrease those and is not an efficient strategy. Getting to know that person and revealing ourselves and group would be worth in this case, as Allport writes in his classic work (Allport 1977). The relationship between ethnic Germans of the selected village and other national minorities is also interesting. Regarding the opinions of the Hungarian majority on minorities of the country, Germans enjoy the top spot. They are viewed as Hungarians as they have assimilated to a sufficient extent in the eyes of the majority; they are equally developed and have a similar way of thought. Ethnic Germans and Hungarians resemble each other the most, Hungarians accept them individually and collectively as well, and view them positively. Negative stereotypes of ethnic Germans are also much weaker towards Hungarians compared to against other nationalities. The level of assimilation is directly proportionate to mutual acceptance. During the period when the village formed a closed community, Hungarians had been called pessimists, people strive on failure, they prefer having fun and spending time in the pub, irresponsibly spending their wealth, and they are not hardworking, diligent and lacking in prudence. These labels have since become positive, Hungarians have acquired a mentality similar to ethnic Germans over the last 20-30 years and the two communities accept each other. This enforces self-esteem in both groups as well as relations.

## Summary

According to the theory of social identity, individual identity is defined by the mindset, value system and character of one's group and our own personal identity affects norms and behavior of our group. This mutual impact shapes prejudices and stereotypes as well. The fact that we continuously rank our own group higher compared to other groups according to standards more important to us shows the importance of collective identity. Social identity is also essential for the group member as a considerable part of his/her own self-esteem originates from the group the person belongs to.

Dangers to collective identity are called social identity threat. These stem from meta-stereotypes: we are afraid that we will be judged by others based on stereotypes applied to the group we belong to or we fear that our personal behavior will reinforce such a stereotype. These meta-stereotypes are particularly relevant in case of interactions between different minorities, most notably ethnic groups.

Hazards to identity may arise due to a number of factors, including physical appearance or differences in social status.

How threatened one feels is influenced by how and to what extent group members consider stereotypes applied to them as valid, what attitude they have, whether other member(s) of the in-group or other groups are present in the particular situation and how they behave.

Ethnic groups may respond to social identity threat in a number of ways: they may avoid interaction of groups; they can reject another group's views; and they may coordinate behavior. Who opts for which strategy in order to avoid a threat to his/her identity depends on motivation, the efficiency of the self, power and social status.

I considered the case of an ethnic German village located in Pest County to examine the phenomenon of social identity threat. Based on my experience, the minority German population has a dual identity: they feel and consider themselves ethnic Germans and Hungarians simultaneously. As a survival strategy, they have acquired the most essential, most necessary knowledge in order to participate in coexistence with the Hungarian majority. An ethnic German adopts elements which are useful, easily attainable and acceptable and which satisfy certain basic requirements but will only be willing to have a dual identity, rejecting full assimilation and surrender of oneself. Furthermore, ethnic Germans also maintain certain negative stereotypes and prejudices towards the majority. Dual identity is thus a form of response to elements, phenomena and tendencies potentially dangerous to ethnic German identity and it also helps reducing conflicts between different groups, while helping self-preservation.

## References

- Allport, Gordon W. 1977. *Az előítélet* [The prejudice]. Budapest: Gondolat, 369-394.
- Bindorffer, Györgyi, 2001. *Kettős identitás* [Dual identity]. Budapest: Új Mandátum-MTA Kisebbségkutató Intézet.
- Bindorffer, Györgyi – Sólyom, Barbara, 2007. A pomázi szerbek identitása [The identity of Serbs of Pomáz]. In: Bindorffer Györgyi (ed.): *Változatok a kettős identitásra* [Variations of the double identity]. Budapest: Gondolat - MTA Etnikai-Nemzeti-Kisebbségkutató Intézet, 188-236.
- Daróczi, Ágnes (ed.), 2001. *Cigányság-identitás-kultúra-történelem* [Roma-identity-culture-history]. Budapest: Magyar Művelődési Intézet és Képzőművészeti Lektorátus.

Fiske, Susan T. , 1993. Controlling other people: The effect of power on stereotyping. *American Psychologist* 48, 621-628.

Fiske, Susan T. 2006. *Társas alapmotívumok* [Basic core motives]. Budapest: Osiris, 511-582.

Síklaki, István, 2010. *Előítélet és tolerancia* [Prejudice and tolerance]. Budapest: Akadémia, 160-178.

Smith, Eliot R. – Mackie, Diane M. 2001. *Szociálpszichológia* [Social Psychology]. Budapest: Osiris, 208-248.

Sólyom, Barbara, 2004. Társadalmi és házassági mobilitás Dunabogdányban [Social and marriage mobility in Dunabogdány]. *Tabula*, 7.(I), 71-96.

Steele, Claude M. - Aronson, Joshua, 1995. Stereotype threat and the intellectual test performance of African Americans. *Journal of Personality and Social Psychology* 69(5): 797–811.

Turner, John - Oakes, Penny, 1986. The significance of the social identity concept for social psychology with reference to individualism, interactionism and social influence. *British Journal of Social Psychology* 25(3): 237–252.

Vorauer, Jackie D. – Kumhyr, S. 2001. Is this about you or me? Self - versus other-directed judgments and feeling in response to intergroup interaction. *Personality and Social Psychology Bulletin* 27, 706-719.

Vorauer, Jackie D. 2003. Dominant group members in intergroup interaction: Safety or vulnerability in numbers? *Personality and Social Psychology Bulletin* 29, 498-511.

# Remarks on the Logic of Irreversible Actions

KOME – An International Journal of Pure  
Communication Inquiry  
Volume 2 Issue 1 p. 37-68  
© The Author(s) 2014  
Reprints and Permission:  
kome@komejournal.com  
Published by the Hungarian Communication  
Studies Association

## Márton Demeter

Károli Gáspár University of the Reformed Church, Institute of Liberal Arts, Hungary

**Abstract:** This paper proposes a logical system in which reversible and irreversible processes could be uniformly handled. This attempt originates in the observation that the question of reversibility not essentially emerges in logic, nor yet in temporal logic in spite of the fact that, in principle, it should be an eminent question as regards any action (where time is the vehiculum and presupposition of change). The situation is quite similar with communication theories, where the expression 'communication' usually refers to an individual process or action in spite of the fact that any process presupposes a given, timeless type for this process. This timeless or time-indifferent types are the prototypes of pure communication.

**Keywords:** reversibility, irreversibility, tense logic, change, action, pure communication

## Philosophical Propedeutics as regards the Idea of Separate Change

The early Wittgenstein wrote in his Tractatus that *«Eines kann der Fall sein oder nicht der Fall sein und alles übrige gleich bleiben»*<sup>1</sup> (Wittgenstein 1921; 1.21.) and, I think, the consequence of this statement is a real philosophical mess-up. Let's call this view the Idea of Separate Change (ISC). In this paper I try to show that ISC is an idea as regards our *models* of the world, but there can be no separate changes in the world itself.

---

<sup>1</sup> Translated by D. F. Pears and B. F. McGuinness as „Each item can be the case or not the case while everything else remains the same” (Wittgenstein 2001)

Let's suppose, for example, that there is an ISC event, namely,  $A\langle aTb\rangle$ , which is an event member of the world  $W_1$ , where  $a$  and  $b$  are individual states of affairs and  $a$  transforms to  $b$  while no other transformations happens in  $W_1$ . Similarly, an event  $B\langle bTa\rangle \in W_2$  could be postulated. Now suppose the conjunction of transformations in A and B as (1) shows:

$$(1) \quad W_1\langle A\langle aTb\rangle\rangle T W_2\langle B\langle bTa\rangle\rangle$$

Now we obtain from (1) by condensation that

$$(2) \quad W_1\langle aTb\rangle T W_2\langle bTa\rangle$$

and then

$$(3) \quad \langle W_1a\rangle T \langle W_2a\rangle$$

But from the definition of ISC it follows that no distinction could be made between  $W_1$  and  $W_2$ : the succession of the transformations A and B results in no transformation, which is absurd. The plain fact that  $W_1$  and  $W_2$  could be indexed as different worlds entails the presupposition that there are at least one difference between them apart from  $a$ . Moreover, its counterintuitive enough to say that successive transformations could be identical with no transformations. Therefore I think that ISC applies to notations, and not to the events of the world.

To buttres up this argumentation many examples could be cited; if the window is open and I close it, and then I open the window again, who could say that I did nothing? Of course I used energy, wasted time and so on. But if a model of the possible states of the window describes the opened-window-state as A, the closed-window-state as B, it could be said that A could be transformed to B and then it could be transformed to A: then this is a reductive notation of the actual processes with identical input and output notation. Similarly, a pure dialogue (with the possibility of any discussion) is the type for every possible (individual) dialogues.

### Handlig events and notations

The relation between events and notations is not self-evident so it has to be analyzed itself. It's trivial that notations are notations of *something*, say events, states, processes and others, so it seems plausible to say that the relation between events and notations is simply that notations are representations of events. The fact that notations are events themselves is far less evident and this recognition leads to infinite regress unless the well known restrictions for object language sentences (notations). Suppose that A is an event and B is the notation of A; but since notations are events, too, B should be represented as C, and than C as D and so on. We can say, of course, that B could be represent both the event B and the notation of this event but in this case events and notations became indistinguishable. Escaping from this situation, logicians started to demarcate object language sentences from meta language sentences, but this effort proved to be unaccomplishable without the aim of further notations, as in the case of (3).

(3) It's raining.

(3b) 'It's raining.'

It could be seen that, as (3b) shows, single quotes notate the notation of the event (3). Notating (3b) requires additional quotation marks and so on, and the problem of infinite regress remains. Obviating this situation logicians started to use the expression 'notation' for its result only, which, at least at first sight, did not seem to be an event. But as a matter of fact, not just the noting, but the reading of a notation is also an event *per se*, since both noting and writing happens in time, and none of them are irreversible. Note, that any communication presupposes a notation, so what holds for 'notation' also holds for 'communication'.

### Basal considerations as regards ISC

Based on the above discussed questions we should ascertain some basal considerations as regards time, change and notations.

- (I) Let the fact that ISC applies to notations and not to the events of the world be our first consideration.

But since noting or reading (so: communicating) a notation is an event too, and notations are in the world, we have to say that, strictly speaking, ISC applies only to the *idea* of notations, and not to the notations themselves.

- (II) Let the fact that ISC applies only to transcendental objects be our second consideration.

But it's hard to say that logic is evidently transcendental. We should skip the ontological questions of mathematics and logics here, and we could still say that whether logic is transcendental or ISC not hold for logic itself.

### Remarks on the concept of notations as events

Of course not Wittgenstein nor later logicians thought that logical representations of any structures refer to events, so the distinction between notations as events and notations referring to events should be made. For example, noting or reading a tautology is always an event, but no tautology refers to any event. In spite of the fact that the ordinary language transcriptions of logical connectives may contain event-words like 'if', 'and' or 'then', there is nothing event-characteristic in their logical equivalents. The above mentioned characteristic of tautologies could be easily apprehended by examining the following formulas.

$$(4) \quad A \equiv B$$

The literal translation of (4) is that A is identical with B.

$$(4a) \quad A \equiv B \supset B \equiv A$$

The literal translation of (4a) is that if A is identical with B then B is identical with A.

$$(4b) \quad A \equiv B \supset \langle A \supset B \rangle \wedge \langle B \supset A \rangle$$

The literal translation of (4b) is that if A is identical with B then if A then B and if B then A.

$$(4c) \quad \langle\langle A \supset B \rangle \wedge \langle B \supset C \rangle\rangle \supset \langle A \supset C \rangle$$

The literal translation of (4c) is that if A then B and if B then C then A then C.

But, unlike ordinary language sentences, logical formulas could be conceived as diagrams. When a formula is conceived like this, the reading of the formulae could be undirected. The following examples are diagrammatic interpretations of (4) – (4c).

$$(4) \quad A \equiv B$$

The undirected diagrammatic interpretations of (4) could be either

that A is identical with B.  
or  
that B is identical with A.

$$(4a) \quad A \equiv B \supset B \equiv A$$

The undirected diagrammatic interpretations of (4a) could be either

that if A is identical with B then B is identical with A.  
or  
that if B is identical with A then A is identical with B.  
or  
that if A is identical with B then A is identical with B.  
or  
that if B is identical with A then B is identical with A.

$$(4b) \quad A \equiv B \supset \langle A \supset B \rangle \wedge \langle B \supset A \rangle$$

The undirected diagrammatic interpretations of (4b) could be either

that if A is identical with B then if A then B and if B then A.  
or  
that if B is identical with A then if A then B and if B then A.  
or  
that if A is identical with B then if B then A and if A then B.  
etc.

$$(4c) \quad \langle\langle A \supset B \rangle \wedge \langle B \supset C \rangle\rangle \supset \langle A \supset C \rangle$$

The undirected diagrammatic interpretations of (4c) could be either

that if A then B and if B then C then if A then C.  
or  
that if B then C and if A then B then if A then C  
or  
that if A then C then it is impossible that if A then B then if C then not-B

Construing undirected diagrammatic interpretations, of course, presupposes precursory knowledge on logical languages, but the situation is the very same with ordinary and conventionally interpreted logical languages, and, as it could be seen by (5) –(5b), with arithmetic itself.

$$(5) \quad 1 = 1$$

$$(5a) \quad 1 + 1 = 2$$

$$(5b) \quad 1 + 1 + 1 + 1 = 2 + 2 = 4$$

Interpreters have to know that addition and equality are reversible and they have to be adept in, at least, some naive number theory (NNT<sup>2</sup>). Then undirected diagrammatic interpretations of the above run as follows.

$$(5) \quad 1 = 1$$

The undirected diagrammatic interpretations of (5) could be either

that 1 equals 1  
or  
that equal-sign connects equals

so (5) could be interpreted as the definition of 1 and the definition of equal-sign alike.

$$(5a) \quad 1 + 1 = 2$$

The undirected diagrammatic interpretations of (5a) could be either

that 1 plus 1 equals 2  
or  
that 2 equals 2  
or  
that 1 plus 1 equals 1 plus 1  
or  
that 2 minus 1 equals 1

$$(5b) \quad 1 + 1 + 1 + 1 = 2 + 2 = 4$$

The undirected diagrammatic interpretations of (5b) could be either

that 1 plus 1 plus 1 plus 1 equals 2 plus 2 equals 4  
or  
that 4 equals 4 equals 4  
or  
that that 1 plus 1 plus 1 plus 1 equals that 1 plus 1 plus 1 plus 1 equals that 1 plus 1 plus 1 plus 1  
etc.

---

<sup>2</sup> Let NNT refer here to adequate knowledge on relational properties of basal arithmetical operations and ordinary knowledge on natural numbers.

Interpreting arithmetical formulas in this diagrammatic way presupposes the following assumptions only:

- (III) Let the fact that the interpreters of arithmetical formulas have to be acquainted with NNT be our third consideration.
- (IV) Let the fact that any formula includes itself, and any concept A includes the concept of A be our fourth consideration.
- (V) Let the fact that the concept of natural numbers includes the concept of any natural number with all the operations on them be our fifth consideration.

Based on the considerations (III) – (V) it has to be said, that any natural number and any valid operation on them asserts the concept of natural numbers. In the same way, any valid structure of logical symbols asserts the concept of the corresponding logical system.

- (VI) Let the fact that any valid logical formulae is a tautology which asserts the concept of the corresponding logical system be our sixth consideration.

### Diagrammatic representations of logical concepts

At this point we could represent the above mentioned tautological structures diagrammatically. The most perspicuous, contemporary way of representing logical structures is the Venn-II system of Sun-Joo Shin (Sun-Joo Shin, 1994, 2006). The following representations harmonize with her system but a few differences will be introduced and elucidated.

(4)  $A \equiv B$

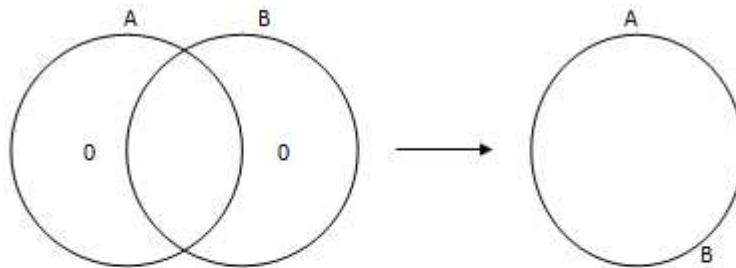

(4a)  $A \equiv B \supset B \equiv A$

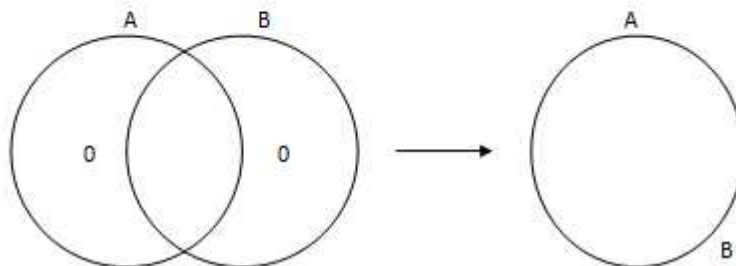

(4b)  $A \equiv B \supset \langle A \supset B \rangle \wedge \langle B \supset A \rangle$

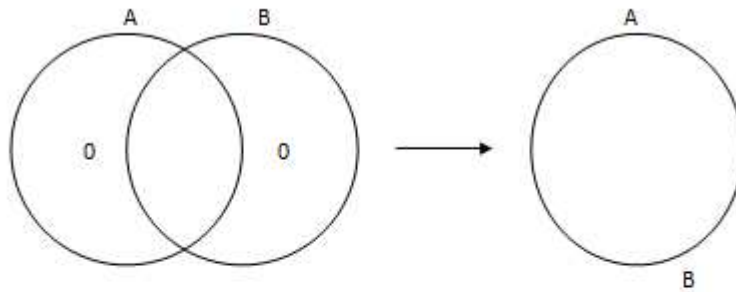

(4c)  $\langle \langle A \supset B \rangle \wedge \langle B \supset C \rangle \rangle \supset \langle A \supset C \rangle$

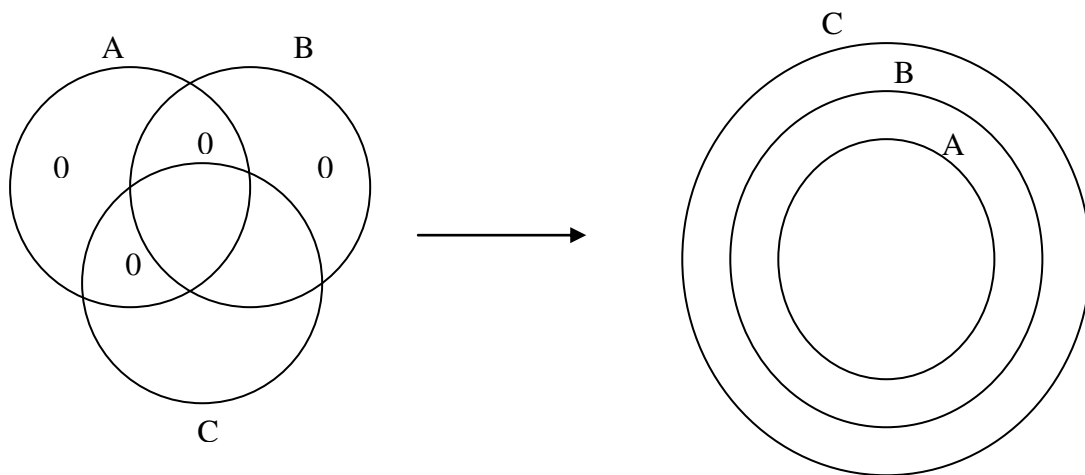
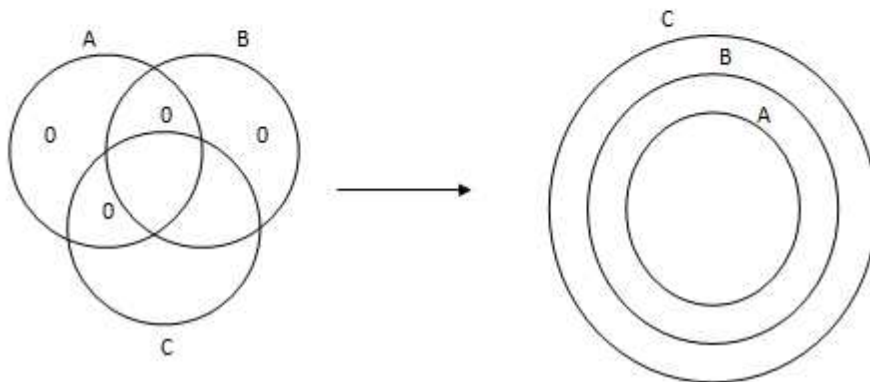

(5)  $1 = 1$

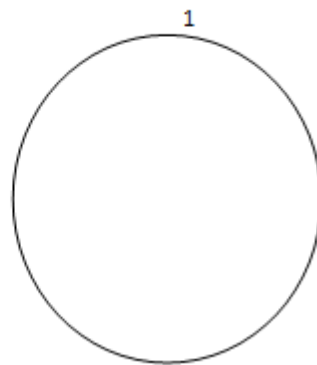

(5a)  $1 + 1 = 2$

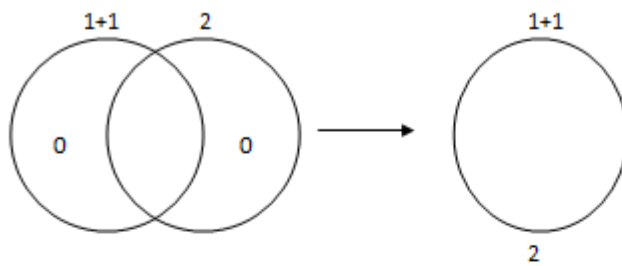

(5b)  $1 + 1 + 1 + 1 = 2 + 2 = 4$

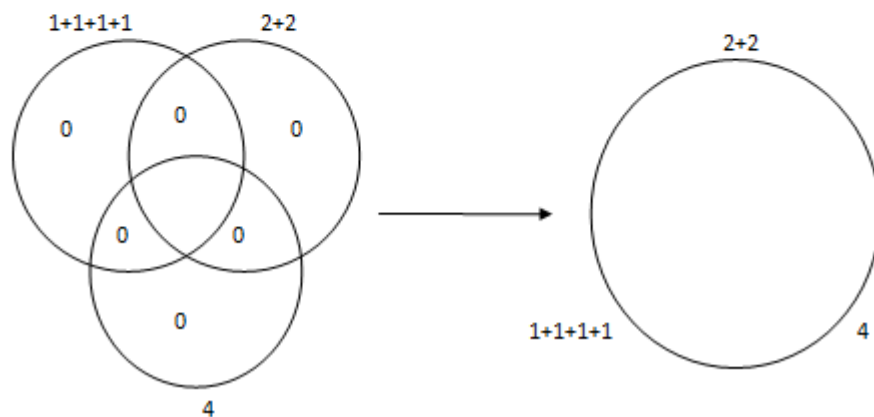

We should interpose some axioms as regards the representations stand above.

- Axiom 1.* Each closed curve represents a set.  
*Axiom 2.* Any closed intersection of sets is a set.  
*Axiom 3.* When a set C is an intersection of sets A and B, then A and B are the parent sets of C.  
*Axiom 4.* Each set should be labelled.  
*Axiom 5.* Labels should be written outside the set.  
*Axiom 6.* Intersections inherit all the labels of their parent sets.  
*Axiom 7.* The label of a set is its name.  
*Axiom 8.* When a set has multiple names, then multiple names signify the same set.  
*Axiom 9.* Any set includes all its members, so a closed curve without any symbol signifies all its members.  
*Axiom 10.* A closed curve with the symbol '0' signifies the empty set.  
*Axiom 11.* Empty sets signifies the same set without respect to their names.  
*Axiom 12.* Empty sets could be deleted without changing the reference of the corresponding representation scheme.

As it could be seen, this representational method can handle the problem of extensional identity that could be stated in spite of intensional differences. Its opposite, viz. the intensional identity despite extensional differences should not be occurred in formal languages.

### **Some additional remarks on ISC**

As we could now delineate, diagrammatic representation systems show that logical expressions need not, and could not refer reversible or irreversible processes or actions, because they do not refer to actions at all. Instead, logical expressions refer to states, which are the preconditions of processes and actions. As against physical and mental phenomena, where the observer encounters with processes alone, the logical sphere consists of states.

(VI) Let the fact that logical expressions (tautologies) are the types of processes be our sixth consideration.

That being the case, we have to differentiate logical types from physical or mental exemplars: the first refer to states, and the second, being temporal derivatives of the first, refer to processes. For example, opening or closing a window is always a physical process; similarly, the intention to close or open a window is always a mental process. But the logical precondition of all the above mentioned processes is a state, i.e. that the core definition of being a window includes that it could be opened or closed. None but this differentiation can lead us to the correct questions as regards reversibility: we should consider that the questions pertain to the exemplars of logical states, namely, physical and mental processes and not to logical expressions themselves.

## Representing types and exemplars: states become processes

In the recent paper we will represent types as hypergraphs, and exemplars will be represented as directed graphs derived from the corresponding type.<sup>3</sup> Note that hypergraph-based representational systems describe *concrete* (non-discrete or analogue) tense logic, while representation systems operating on directed graphs describe *discrete* tense logic. This remark should be considered later, when non-logical expressions like 'next', 'until' or 'now' will be analyzed. Since there are no temporal expressions apart from 'always' and 'at least once' that could be handled as logical expressions<sup>4</sup>, the above mentioned terms belong to physical and mental languages: consequently, they will be represented as directed graphs.<sup>5</sup>

Before constructing a graph system based on the above mentioned considerations it should be mentioned that, contrary to the usual graph constructions which derive hypergraphs from normal graphs, the basis of our recent system will be the hypergraphs themselves, and normal graphs will be the derivatives. This sequentiality corresponds to the consideration that exemplars (processes and actions) always derive from possible states i.e., from types. Let's call this type-exemplar graph system TEGS hereunder. As it could be conjectured, a TEGS consists of types and exemplars where types are the basal entities. A simple representative of TEGS could be constructed as follows.

*Definition 1.* A  $G = (V,E)$  graph consists of the sets  $V$  and  $E$ ; the elements of  $V$  are the  $v \in V$  vertices, the elements of  $E$  are the  $e \in E$  edges.

*Definition 2.* For every edge  $e$ , there is a set  $C$  contains  $c$  vertices which are the *end vertices* of  $e$ .

*Definition 3.* If  $v$  is the end vertex of  $e$ , then  $v$  *suits*  $v$  and  $e$  *suits*  $v$ .

*Definition 4.* Let's call the  $n$  number of edges between vertices *multiplicity*.

*Definition 5.* Let's call the  $c$  number of vertices suits  $e$  the *cardinality* of  $e$ .

*Definition 6.* Let's call the  $k$  number of edges suits  $v$  the *degree* of  $v$  [ $(\varphi(v))$ ].

*Definition 7.* If  $e$  suits  $n$  vertices and  $n = 1$ , then  $e$  is a *knot*; if  $e > 1$  then  $e$  is a *proper edge*.

*Definition 8.* The set of minimum 2 proper edges or knots suit the same end vertices is a *multiedge*.

*Definition 9.* A graph wherein  $c$ ,  $k$  and  $n$  are unspecified is a *hypergraph*.

*Definition 10.* A *simple graph* could be derived from a hypergraph, wherein  $c \leq 2$  and  $k$ ,  $n$  are unspecified.

*Definition 11.* The alternate sequence of edges and vertices in a  $G$  graph is the  $W$  walk.

$$W = \{v_0, e_1, v_1, e_2, \dots, e_n, v_n\}$$

*Definition 12.* If there is a walk between  $v_1$  and  $v_2$  then  $v_1$  and  $v_2$  are *accessible* vertices.

*Definition 13.* A graph is *connected* when all its vertices are accessible from each other.

*Definition 14.* Both edges and vertices could be *labeled*. Labels are represented with colours. Edges and vertices with the same colour belong to the same *label class* (LC).

<sup>3</sup> In this paper we treat types and exemplars from a basal logical point of view. In the case of our diagrammatic system, types are labelled with capital letters (A), and exemplars are labelled with lower cases (a). We will later specify the logical properties of types and exemplars, but for the sake of an anticipatory understanding one could correspond them with the sentential calculus; then exemplars correspond to individual propositions (p,q), and types correspond to general propositions ( $\varphi, \phi$ ).

<sup>4</sup> Where 'always' is the temporal equivalent of the universal, and 'at least once' is the temporal equivalent of the existential quantifier.

<sup>5</sup> According to Tarski, no logical expressions may refer to temporality (future, past) at all.

Consider a representative of TEGS on Fig1.

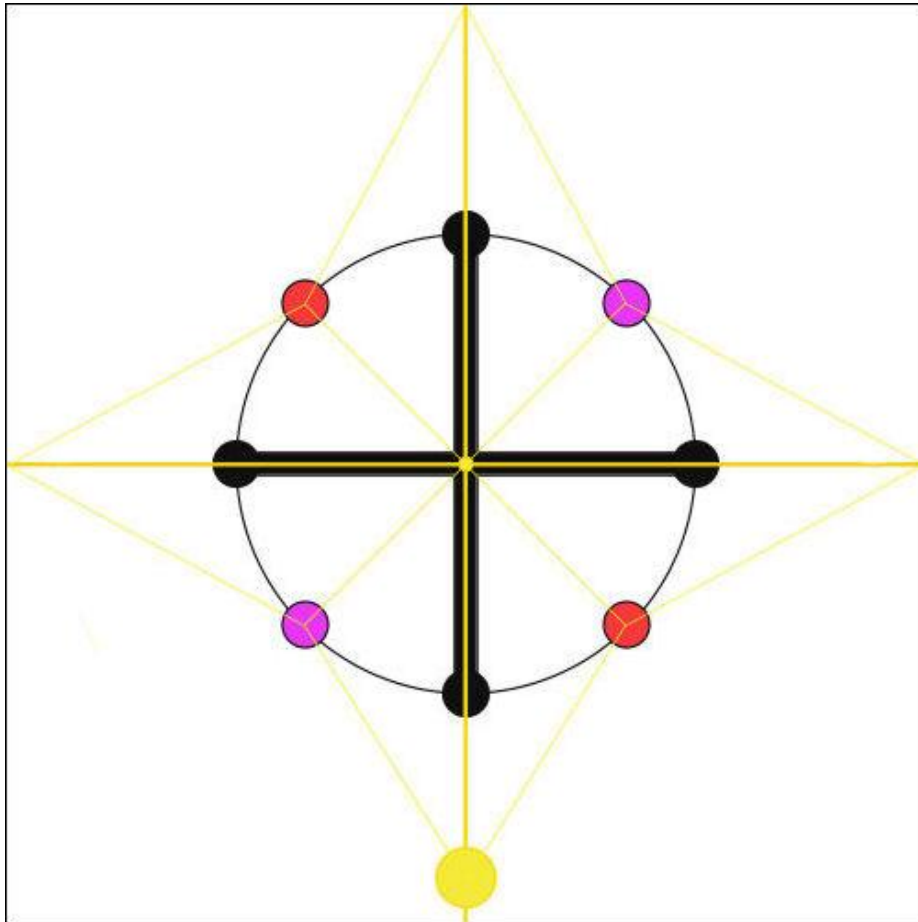

Fig 1. A representative of TEGS . Different colours represent different LCs.

The TEGS represented by Fig 1. is a connected simple graph with hypergraphs as its vertices. All its edges and vertices are labelled. Nevertheless this paper will be concerned with graphs with only one LC, because it focuses on tense logical problems where different LCs are not needed.

*Definition 15.* The vertices and edges belong to the same LC are the *fragments* of that LC ( ${}^t\text{LC}$ )

*Definition 16.* If fragments  $x,y$  have an edge that  $e: (x,y)$  and  $x,y \ni \text{LC}$ , than  $x$  and  $y$  are accessible from each other *simply*.

*Definition 17.* If fragments  $x,y$  aren't accessible from each other simply, but they have an edge that  $e: (x,y)$  and  $x \ni \text{LC} \wedge \neg y \ni \text{LC}$  or  $y \ni \text{LC} \wedge \neg x \ni \text{LC}$  than  $e$  is a bilateral edge, and  $x,y$  are accessible from each other *synthetically*.

By definition 17. it follows that fragments of the same LC are accessible from each other simply, fragments of different Lcs are accessible from each other synthetically. Different LCs are represented by different colours on TEGS and they could be indexed as  $\text{LC}_1, \text{LC}_2$  and so on. Any representative of TEGS could be constructed as a complex of LC(s) so a TEGS is a recursively constructed class of hypergraphs, which are the basis graphs of TEGS.

To represent exemplars, types need to be dissolved as follows.

*Definition 18.* The  $P_2$  structure of an  $H: (V,E)$  hypergraph induces a 2-vertices walk on  $H$ ; now  $P_2H$  shows the  $v \ni V$  vertices induces the fitting  $e \ni E$  edge.

*Definition 19.* Dissolving an  $H: (V,E)$  hypergraph results in the  $P_2H \subset H$ .

*Definition 20.* The  $R: \{V=( \dots, v_0, v_1, v_2, \dots), E=( \dots, v_0v_1, v_1v_2, v_2v_3, \dots)\}$  subgraph of the  $H: (V,E)$  hypergraph is its *radius*.

Now states and processes could be represented by TEGS as follows. The first relation is the most simple as it represent that any part of the LC could be access from its basal LC (fig2). Note that, as *Definition 20.* states,  $R$  is a subgraph of the dissolved hypergraph labelled with the corresponding LC. In our undermentioned examples LCs will be represented with colours (black, red etc.).

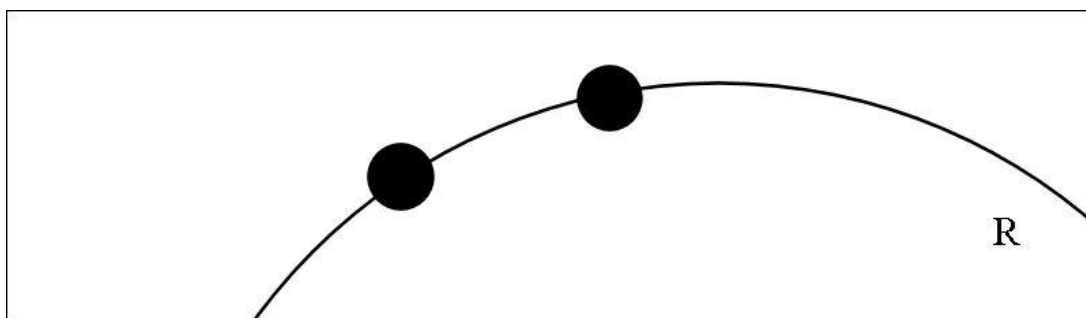

Fig 2. Any part of an LC could be simply access from the LC.

The relation that Fig 2. shows is the diagrammatic equivalent of inclusion. For a conceptual example, suppose that an LC carries the label 'Number'. Now any part of that LC, say, 'rational number' carries the label 'Number' at the same time. Without direction, Fig 2. could represent the state that, for example, A and B are the parts of the  $R \langle LC \rangle$ . For an everyday language example that had been formerly quoted, suppose that the LC represented with black on Fig 2. carries the label „Window”. Then Fig 2. could represent the state of being an opened window and the state of being a closed window are parts of being a window. It means, conceptually, that the concept of window includes the possibilities of being opened and being closed: these possibilities are determined by the basal concept.

The second relation on Fig 3. shows that any fragment of an LC could be simply access from the LC.

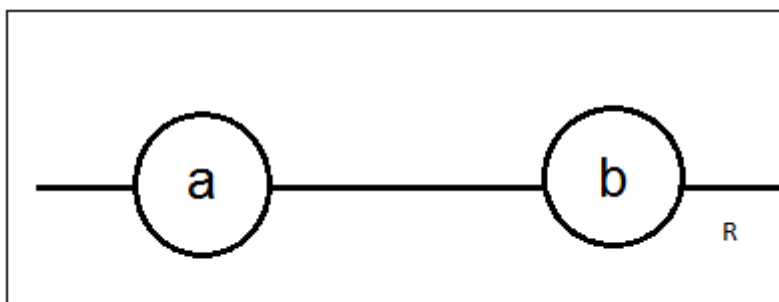

Fig 3. Any fragment of an LC could be simply access from that LC.

As it could be seen, on Fig 3. the fragments of the LC are named (as A and B), so the graph shows the relations between  $LC : A : B$ . But naming fragments is not necessary: without additional marks, a blank closed curve means 'a fragment of that LC include it'. Some logicians use the symbol 'O' representing the empty set, viz. types without fragments but this

representational tradition could not be harmonized with our conception of graphical logic from causes we could only touch here.

In the case of diagrammatic logic, iconicity is a very important factor, so the so-called negative fact should not be represented, if it is possible. For example, to represent the fact that A is an empty set, we have better ignore the representation of the set A instead of labeling a set with A, and then mark it with a 'O'. This could be considered as the extensional criteria for TEGS. An intensional criteria should be formulated as well, because one could state that even if a set hasn't got any elements, we should represent the set itself as it could be labelled lucidly. For example, the set of round squares are empty, but the label 'round squares' could be considered intelligible (even if I think that it is not the case). As regards diagrammatic representation, the situation is very simple here because only that fact has to be represented that the set of round things and the set of squares are disjuncts. A slightly more difficult problem may emerge with labels like 'centaur' in spite of the fact that many logicians thought that they should be analysed in the same way that round squares: centaurs should be represented as an empty intersection of the sets 'man' and 'horse'. I think that an analysis of that kind may violate our conception of normal language usage, because 'centaur' does not seem like a complex expression at all. So I propose that empty sets, which are not to be represented as intersections could be represented as types without exemplars. In this case, the representation refers to the existence of a label, for example, it could show that we have the conception of centaurs (but we don't actually know exemplars falling into this category). The issues of the above mentioned considerations are shown at Fig 4.

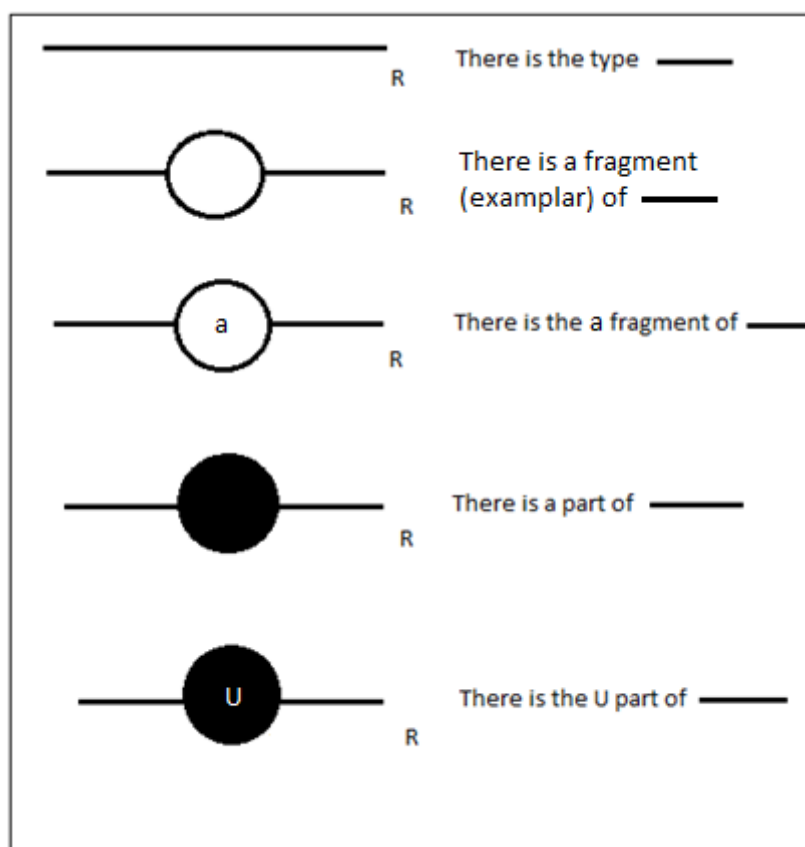

Fig 4.

In addition, Fig 5. shows the relations of universality, uniqueness and definite uniqueness in TEGS.

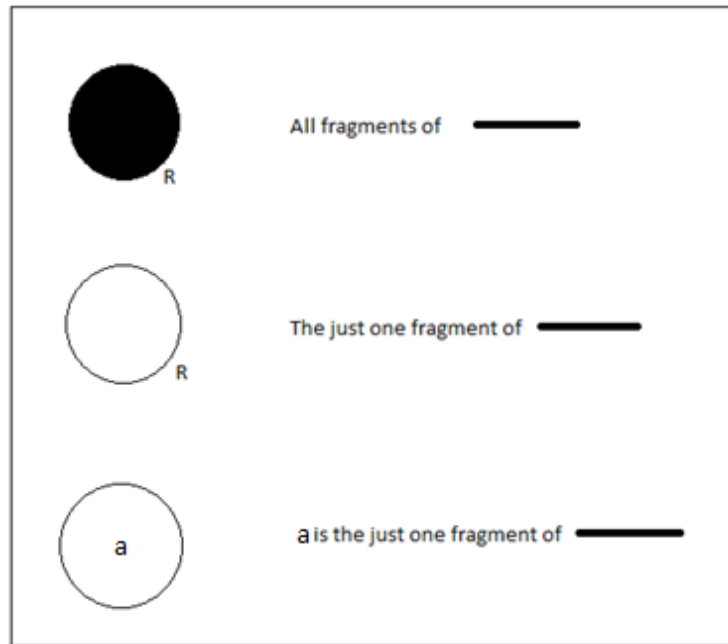

Fig 5.

Now the well known logical relations could be represented by TEGS as Fig 6. shows.

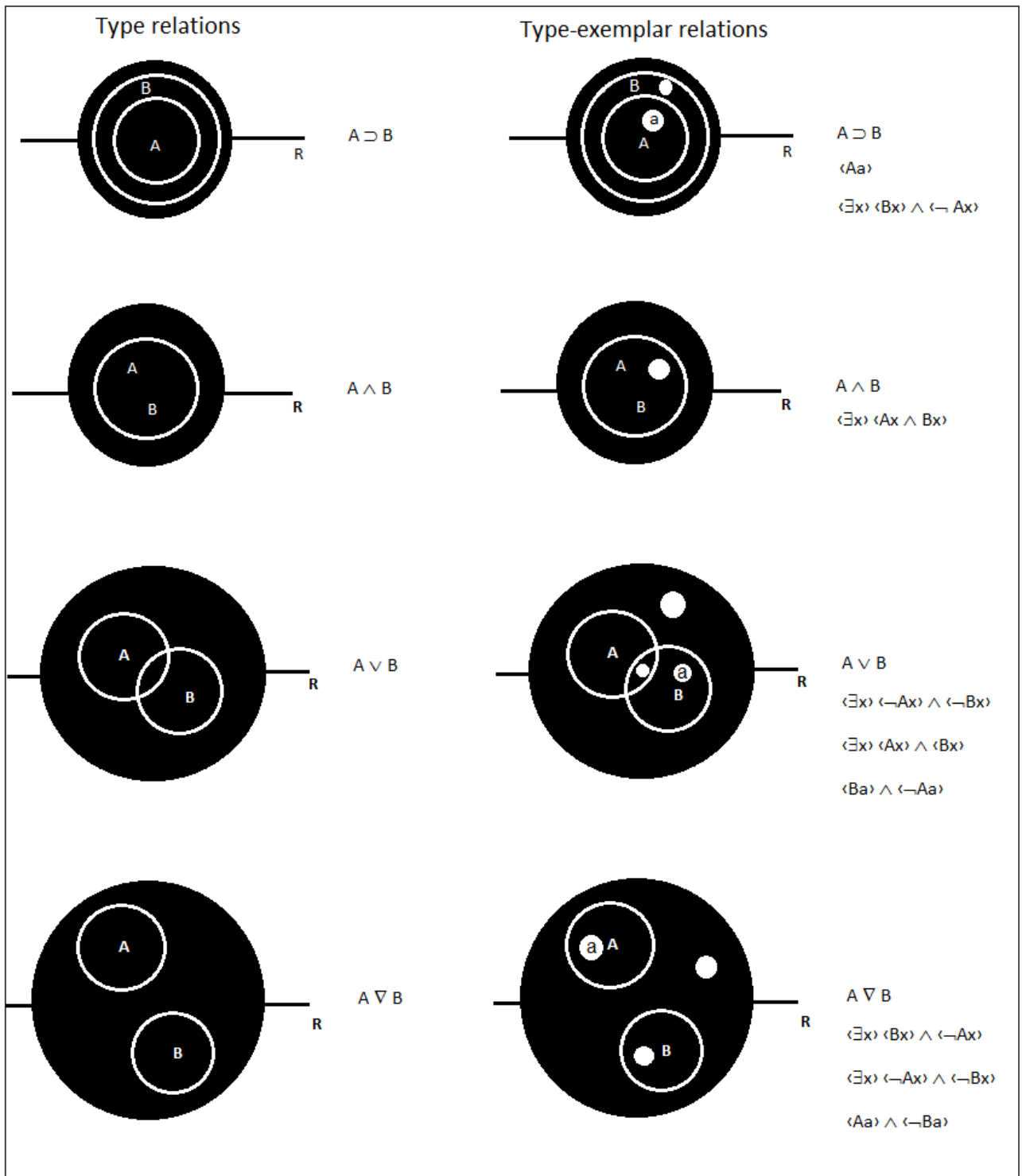

Fig 6.

For a better understanding consider the following examples.

*Example 1.*

Let  $R$  be the part of the LC with the label 'Man'; let „ $A$ ” represent the type 'Male', let „ $B$ ” represent the type 'Female' and let „ $a$ ” represent 'Adam'. Now consider Fig 7.

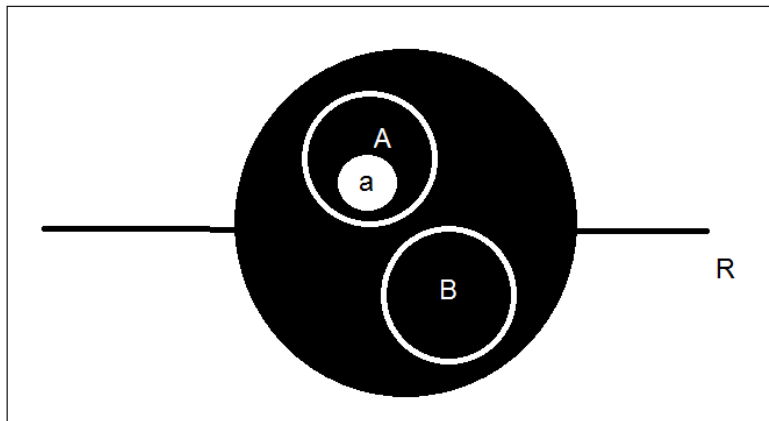

Fig 7.

*Example 2.*

Let  $R$  be the part of the LC with the label 'Window'; let „ $A$ ” represent the type 'Opened thing', let „ $B$ ” represent the type 'Closed thing' and let „ $a$ ” represent a definite description of an individual window at a given time. Now consider Fig 7. again.

Of course there can be logical states where we have to operate on different LCs. Then, as it had been mentioned earlier (see Definition 17.) the accessibility of the constituents is synthetical. But in this paper we won't need the representations of synthetical accessibilities because we will focus on the problem of time and change, and this could be considered as a one-dimensional problem as regards LCs. Of course there are philosophical problems that could not be handled without different LCs, and the most obvious of them are presumably the so-called body-mind problems, or the problem of propositional attitudes, where physical and mental states have to be differentiated by different LCs. It stands to reason that the above mentioned problems could not be discussed in this paper.

As regard our original problem, we earlier said that the questions of states and processes could be handled by representing only one LC, because we only consider here physical changes in time. Now we have the representations of logical relations and we said that they representing logical states, so they could not, and should not represent processes at all, but they are the presuppositions of any process. So hereunder we should deal with processes as they are derivated from states.

It seems obvious, that types are not subjects to change, because they are the bases to any change could be conceived. For example, if  $A$  is the type of a closed window and  $B$  is the type of an opened window,  $A$  could not became  $B$ , but an individual window could fall under  $A$  in  $t_1$ , and fall under  $B$  in  $t_2$ .

*Definition 21.* An  $e: (v_1, v_2)$  edge is *directed*, when its end vertices are ordered as  $v_1 \rightarrow v_2$ . Here  $v_1$  is the *initial verticle* of  $e$ , and  $v_2$  is the *terminal verticle* of  $e$ .

*Definition 22.* An edge with ordered vertices is the  $a: (v_1 \rightarrow v_2)$  *arc*.

*Definition 23.* The  $W = \{v_0, e_1, v_1, e_1, \dots, e_n, v_n\}$  walk is a *directed walk* when it has an arc in its set of edges. Then  $v_0$  is the initial verticle,  $v_n$  is the terminal verticle, and any other vertices in  $W$  are *internal verticles*.

Now directed TEGSs could be drawn with initial, internal and terminal vertices. The most basal interpretation of  $\rightarrow$  is undeniably the temporal interpretation: then  $\rightarrow$  means temporal succession, so  $v_1 \rightarrow v_2$  should be interpreted as 'v<sub>1</sub> precedes v<sub>2</sub>' or 'v<sub>2</sub> follows v<sub>1</sub>'. A more problematic interpretation of  $v_1 \rightarrow v_2$  could be that 'if v<sub>1</sub> then v<sub>2</sub>'. Since the latter interpretation suggests implication, some remarks should have been taken here as regards inclusion and implication.

According to the philosophy of this paper, inclusion (or entailment) is a logical relation between types, and it evokes logical necessity. For example, the type 'Number' includes the type 'Rational number' so it is logically impossible to be a rational number and not to be a number. When  $a$  is a rational number then it must be a number by logical necessity. On the other hand, implication evokes factual necessity, like in the case of physical laws. The fact that if I lose hold of an apple then it will fall down is governed by physical, but not logical laws, so it cannot be represented by inclusion. Finally, the weakest sense of implication could be called hypothetical implication, like in the case of the statement 'If you don't go I'll call the police'.

With regard to the above mentioned differences we denote inclusion (logical consequences) with closed curves as before. Now let's introduce the sign  $\Rightarrow$  for factual implication, so  $v_1 \Rightarrow v_2$  means that 'v<sub>1</sub> causes v<sub>2</sub>'. Finally, let's maintain the sign  $\rightarrow$  for temporal succession.

Now basal temporal questions could be represented starting with the most simple one viz. when a process is a simple change of states without any agent (see fig 8.)

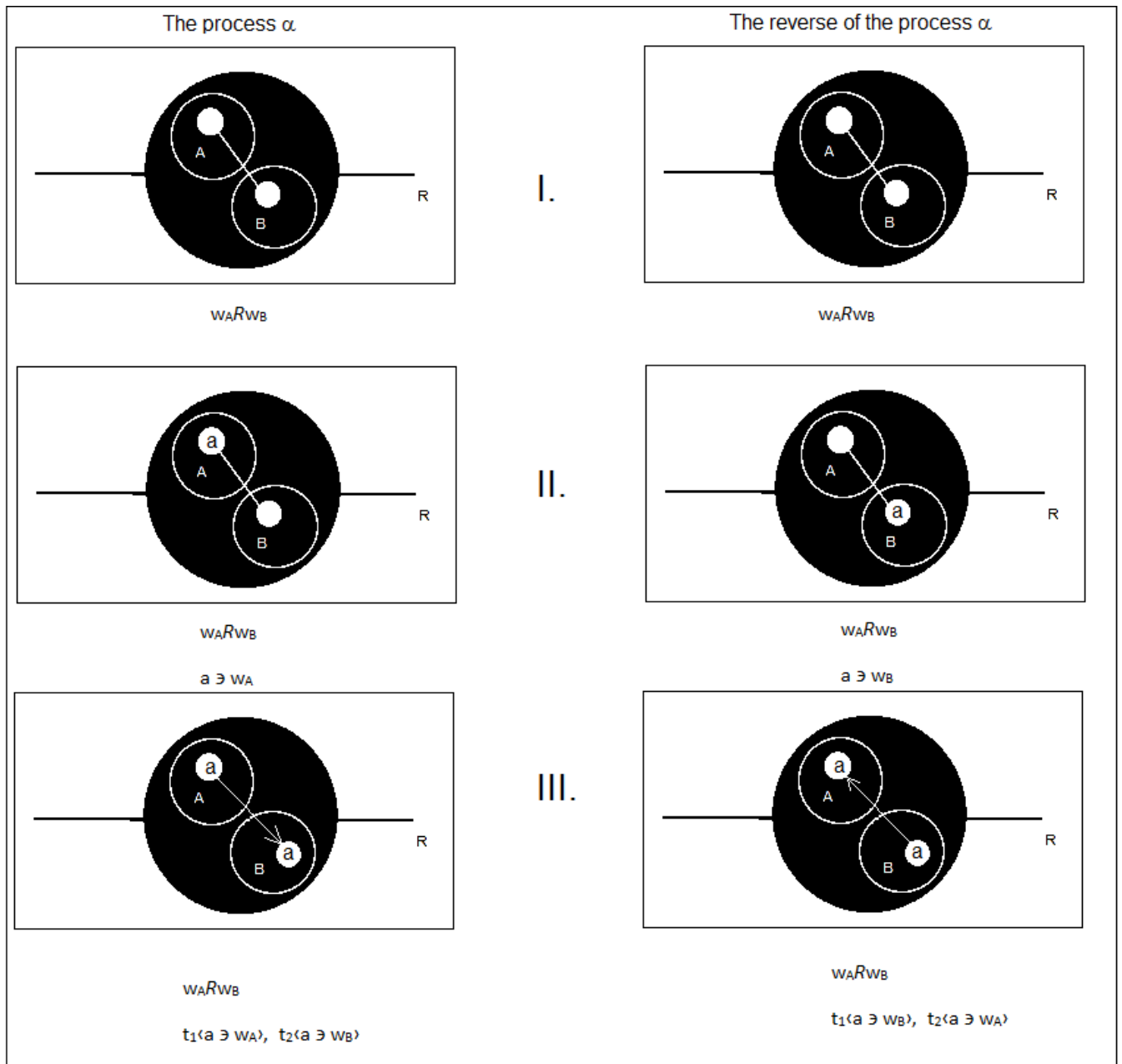

Fig 8.

Fig 8. shows a simple change of states without the indication of an agent and it also shows the reverse process. Figures in the line I. show that the presupposition of both processes is the condition that there are exemplars of type A and type B and they are accessible from each other. Symbolically it could be expressed as accessibility relations between possible worlds  $w_A$  and  $w_B$ . Figures in the line II. show the position of individual  $a$  at  $t_1$ . Finally, figures in the line III. show the process that  $Aa$  becomes  $Ba$ , and its reversal, when  $Ba$  becomes  $Aa$ .

### Processes become actions

Actions are processes with agent(s), who cause(s) change(s) in time. A typical action could be represented by TEGS as figure 9. shows.

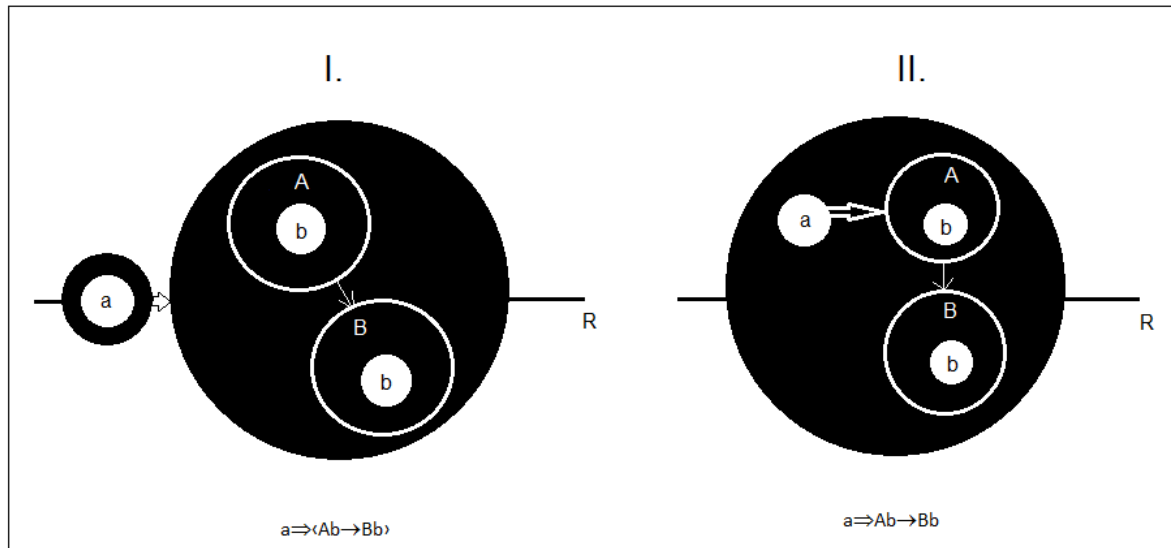

Fig 9. Two ways of representing actions in TEGS

As it could be seen by Fig 9. even elementary actions can lead to alternative explanations. First, as I. shows,  $\langle$ the change of  $b$  from  $A$  to  $B$  by  $a$  $\rangle$  could be conceived as  $a$  causes the process that  $Ab$  becomes  $Bb$ . Second, as II. shows, it could be interpreted as  $a$  causes the state  $Ab$ , and if  $Ab$ , then  $Bb$ . In any way soever, diagramatization could clarify the situation. Note that some logicians suggest constructing separate diagrams for every state (we will refer to this idea as 'separate-diagrams-tradition' or SDT), so we have to defend our position that we use only one diagram for representing processes and actions. For this reason we should mention one another consideration.

(VII) Let the fact that any individual could take up only one (logical) place at a given time be our 7th consideration.

Now it follows from (VII) that, normally, a given exemplar has to itinerate during change, so initial vertices has to be deleted as their contents (the individuals) become terminal vertices. Nevertheless, as Fig 10. shows, taking notice of (VII), our representational method TEGS (I.) and SDT (II.) are in correspondence.

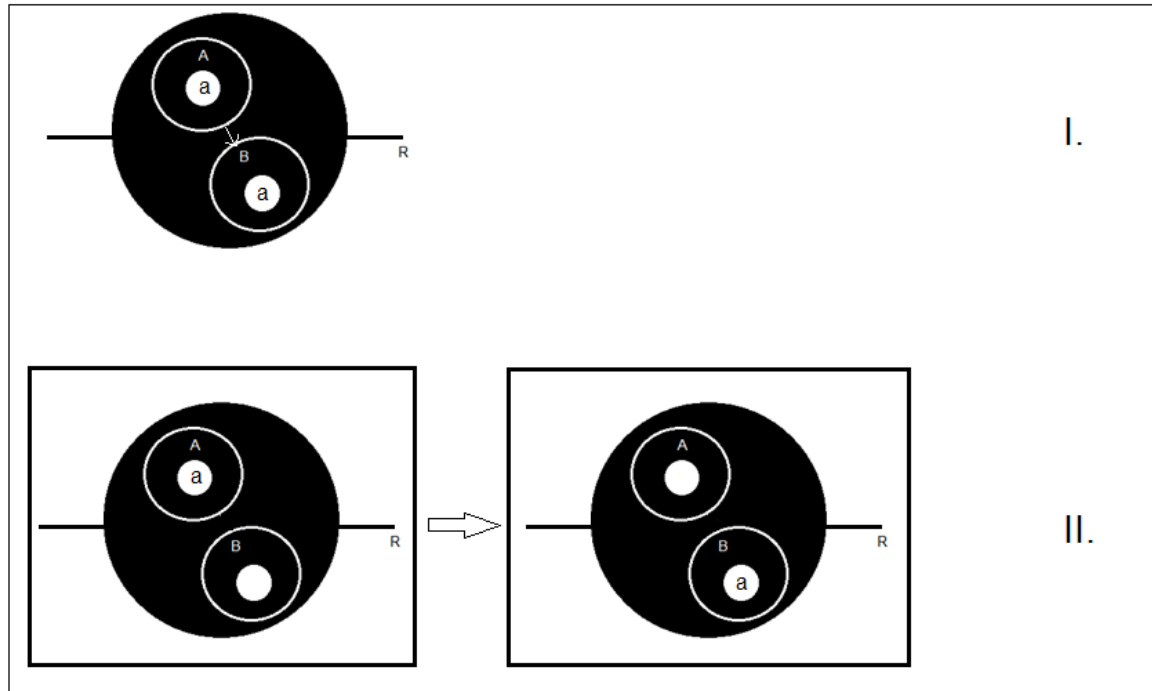

Fig 10. The diagrammatization of change with TEGS (I) and SDT (II).

However, beside simple change of states, there are at least two typical processes, namely *addition* and *abstraction*. In the case of addition, an entity broadens and acquires new properties, while in the case of abstraction an entity narrows and loses properties. Now we can symbolize addition as  $Aa \rightarrow Aa \wedge Ba$ , and abstraction as  $Aa \wedge Ba \rightarrow Aa$ , and Fig 11-12. show their diagrammatization by TEGS and SDT.

Note that (VII) still applies on addition and abstraction because both the process  $\langle Aa \rightarrow Aa \wedge Ba \rangle$  and  $\langle Aa \wedge Ba \rightarrow Aa \rangle$  change the logical position of  $a$ . The illustration of addition and abstraction by traditional Venn-methods (signed with III. on both Fig 11. and Fig 12.) make the situation apparent.

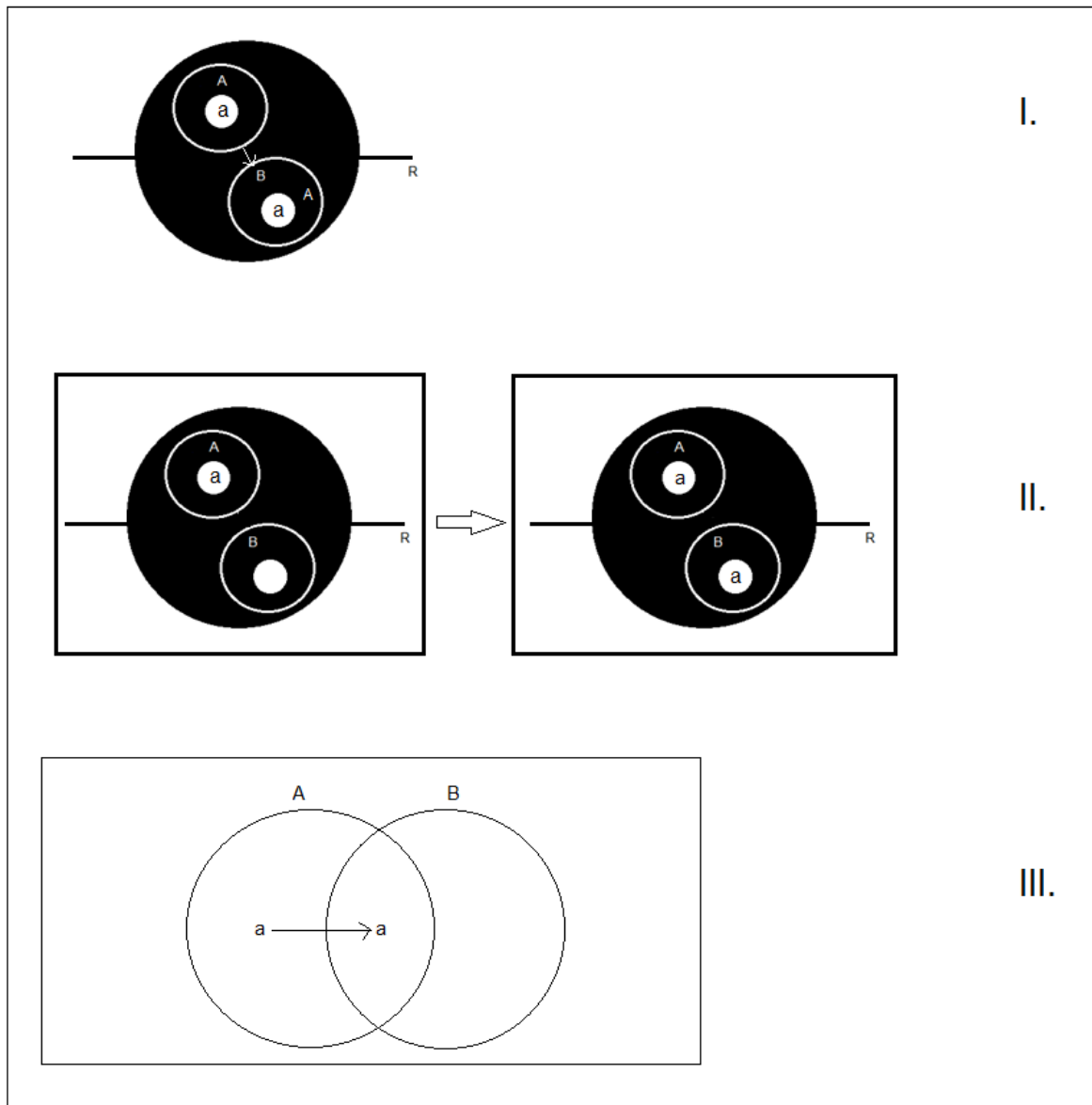

Fig 11. Addition, represented by TEGS (I) SDT (II) and Venn-diagramms (III).

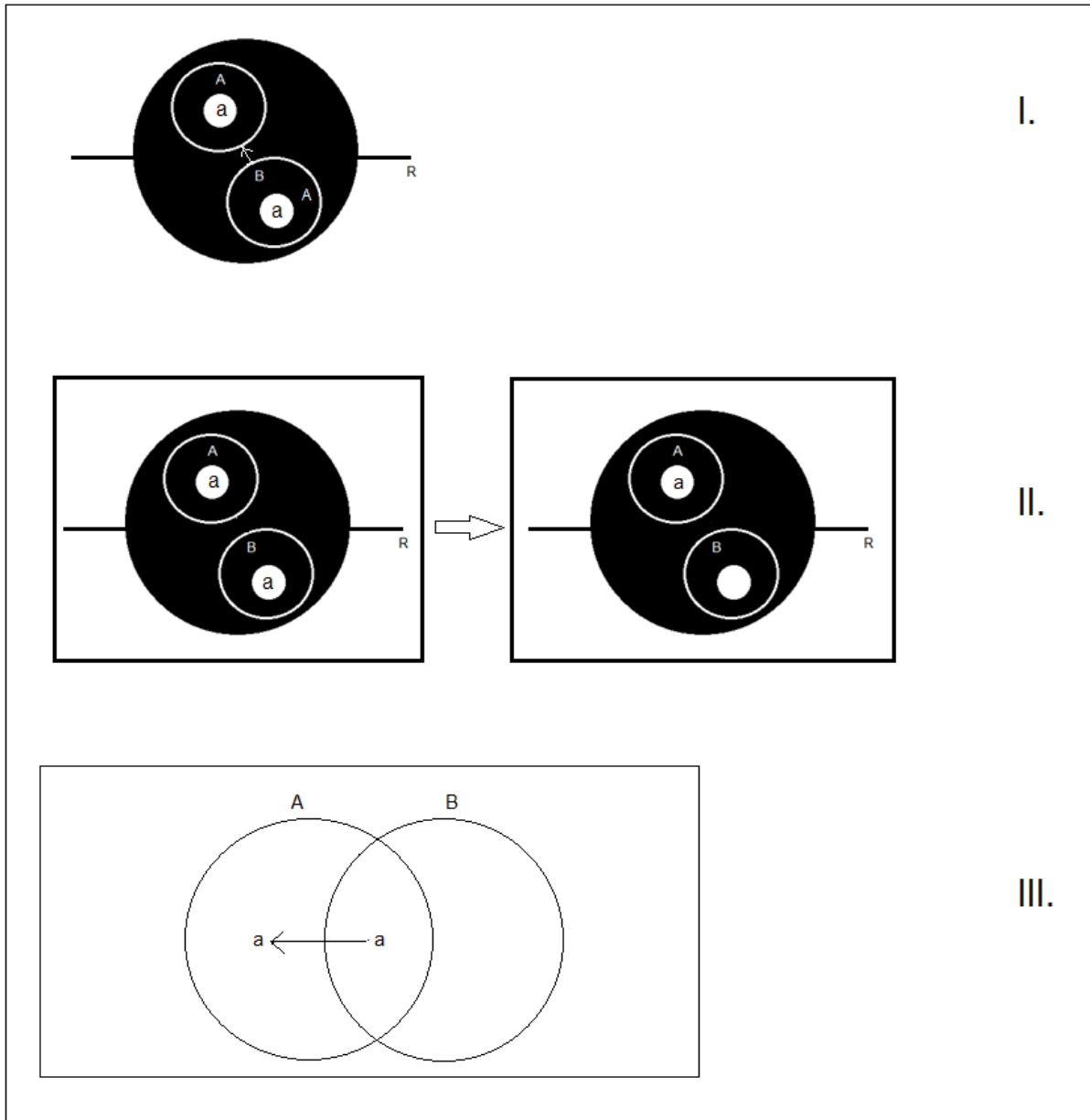

Fig 12. Abstraction, represented by TEGS (I) SDT (II) and Venn-diagramms (III).

**Interpreting related systems of temporal logics in TEGS: T-calculi**

The first system we would like to interpret in TEGS will be Von Wright’s T-calculi as it was presented in his Norm and Action (Wright 1963). Note that we could only mention the basal ideas and notation (Fig 13.)

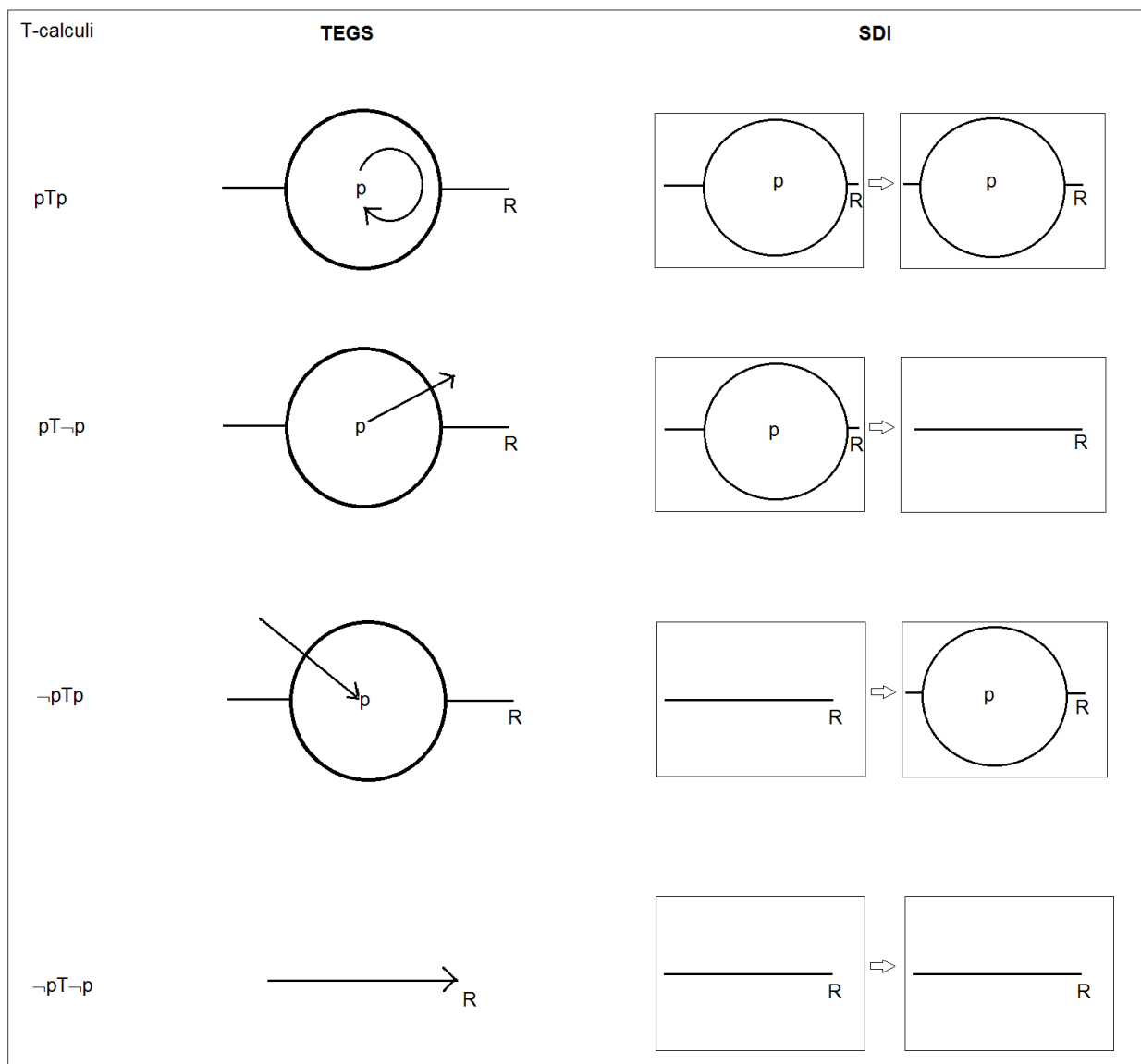

Fig 13. Primary relations in T-calculi, TEGS and SDT.

The first line expresses no change but time with a given content  $p$ . Note, that only *types* are constants; on the other hand, exemplars *have to* change at least inasmuch as they exist at *different* moments, while types exist timelessly. The second line expresses termination while the third line shows formation. Finally, the fourth line (like the first one) expresses no change but time without any content. Note that without positive facts, tense-operator expresses only the change of time, viz. the pure container of any possible change.

A more problematic application of T-calculi will be represented on Fig 14. with the original scheme of Von Wright. Note that, from a diagrammatical point of view, his scheme seem to be elliptic in the sense that they should be augmented with presuppositions. For example, his first scheme runs as  $pTq$ , but it can be conceived in many ways. Based on the complex formula, we could extricate two states (S1,S2) and the relation T. The complex formula contains information about two propositions (p,q) but elementary formulas (S1,S2) affirm only one of them: so the position of the suppressed proposition should be presupposed. Then  $pTq$  could be interpreted 4 ways (explicit information is marked with bold).

- a.  $p \wedge q \mathbf{T} p \wedge q$
- b.  $p \wedge q \mathbf{T} \neg p \wedge q$
- c.  $p \wedge \neg q \mathbf{T} p \wedge q$
- d.  $p \wedge \neg q \mathbf{T} \neg p \wedge q$

Now Fig 14. shows the interpretations of T-calculi with two propositions.

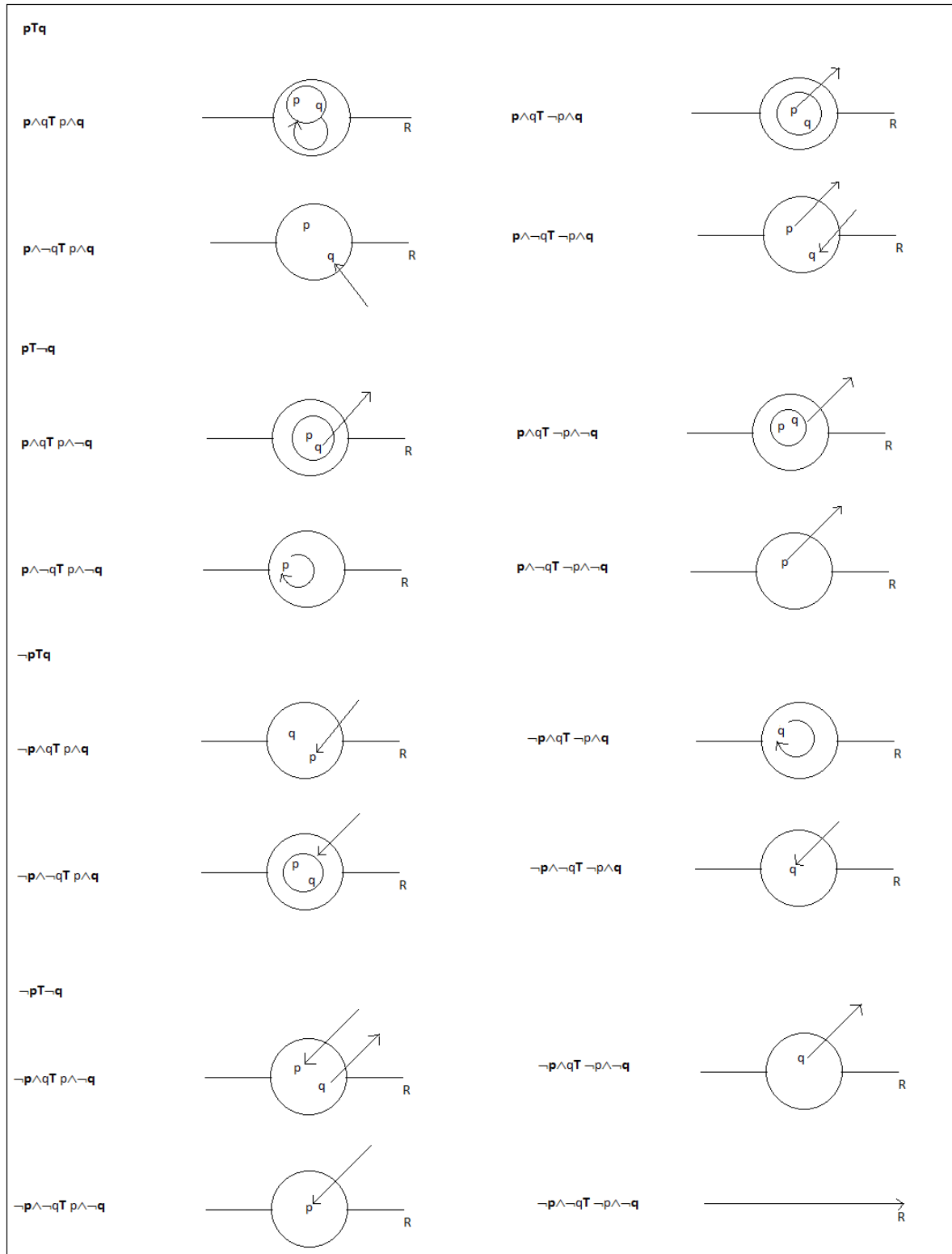

Fig 14. T-calculi and TEGS with 2 propositions

**IBT**

Our second system is based on the idea of branching time (IBT) as it has been interpreted by Prior and Kripke (Prior 1967, Ohrstrom – Hasle 1995). The main problem as regards IBT is indisputably the question of determinism, but we won't be concerned with it as our interests are the structural properties of IBT here. But since in IBT the direction of time is structurally decisive, we should analyse its representative methods first.

According to Galton (Galton 1987) there are at least four ways of representing the topology of time, namely the linear, the parallel, the branching and the circular representational systems. Note that the above mentioned four concept could be reduced to linear and nonlinear ones, since linear time could be considered as hapax linear (single linear), as bilinear (parallel) as multilinear and as branching time. But they are not distinct topological systems, because, as Fig 15 shows, the more complex topologies could include simpler ones. Let us represent the topology of the different time concepts as follows.

- [A] The topology of nonlinear time
- [B] The topology of hapax time
- [C] The topology of bilinear time
- [D] The topology of multilinear time
- [E] The topology of branching time

Let the index TC signify the topological complexity of different topological structures. Topological complexity means that representations with more TC could include representations with less TC. Now Fig 15 shows that  $[A]_{TC} < [B]_{TC} < [C]_{TC} < [D]_{TC} < [E]_{TC}$

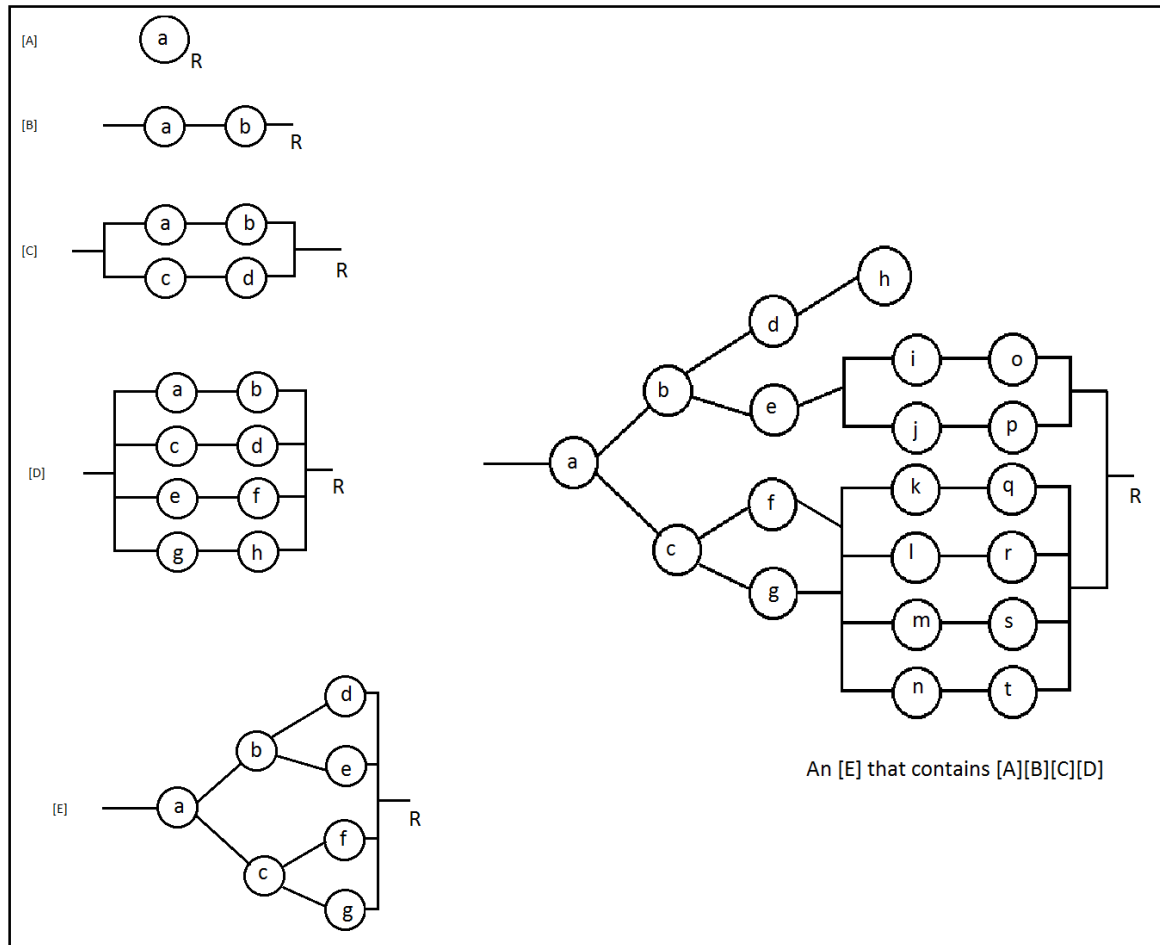

Fig 15.

Fig 15. shows that [E] could include [A] or [B] or [C] or [D]; the diagram on the right shows that an [E] contains an [A] (see unit 'a'), a [B] (see, for example units 'a-b'), a [C] (see units 'i -j-o-p') or a [D] (see units 'k-l-m-n-q-r-s-t'). But it also shows that logical connections as regards parallel and branching time are different; in the case of the former the connection is 'AND', while in the case of the latter it is „XOR". Parallel time concepts could be interpreted at least two ways. The first is the simpler one because it only suggests that different propositions could be true at the same time (as in the case of [C] on Fig 15. It simply means that parallel states could exist simultaneously. But the second interpretation could suggest a more problematic situation that could be represented as Fig 16 shows.

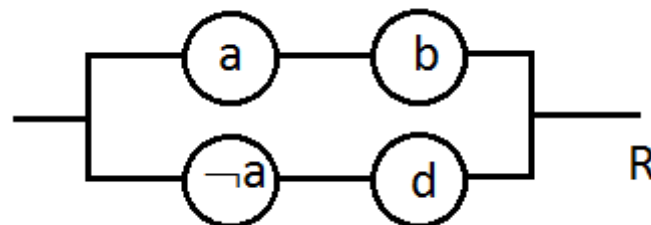

Fig 16.

As opposed to the first interpretation Fig 16. shows a situation where a and not-a could be simultaneously true in parallel times. But this curiosity is not important for us here, so let us get on to our original subjects, namely types and exemplars.

The simpler challenge is apparently the question of exemplars: we plainly have to direct the edges of the appropriate graphs.

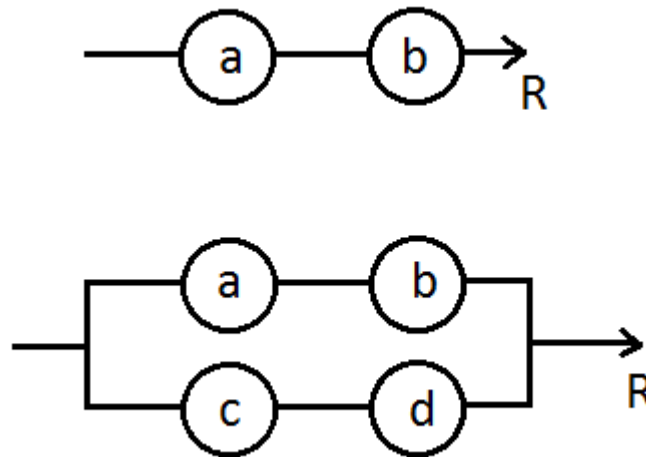

Fig 17.

Note that we need not direct all edges because the sequential order could be indicated by directing R only. Consider moreover that this way of representing temporal sequences shares problems with the T-calculi as it is elliptic too. For example, 'the change from a to b' could be interpreted either as 'the change from  $\langle a \rangle$  to  $\langle b \text{ and not-}a \rangle$ ' or as 'the change from  $\langle a \rangle$  to  $\langle a \text{ and } b \rangle$ '. Even though this kind of ambiguity significantly increases in the case of IBT we won't deal with it because the thickening here is basically simply combinatorial so it could be handled by means of the considerations as regards the interpretation of T-calculi.

Representing types is far more interesting because we have to show that type-structures should not contain directed edges. For this end we will show that *structural* succession is not a question of time, but a question of encompassment.

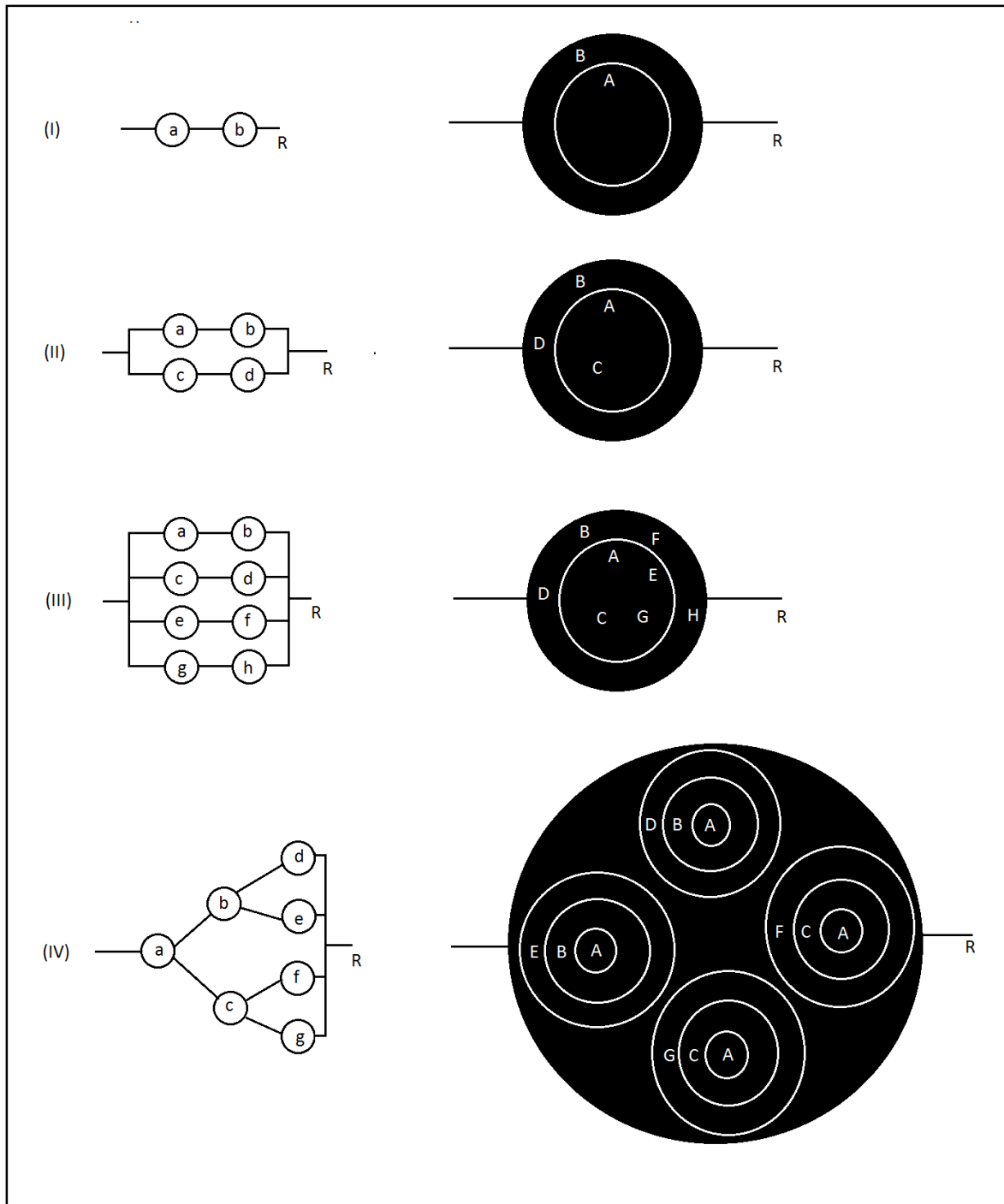

Fig 18.

Now Fig 18. shows that parallel and branching time-concepts could be represented without directed edges when we represent types instead of exemplars. Note that while IBT representations show temporal relations, TEGS interpretations show the logical structure itself. So representations on Fig 18. should be interpreted as follows.

- (I) If A then B
- (II) If A and C then B and D
- (III) If A and C and E and G then B and D and F and G
- (IV) If A, then either B or C  
If B, then either D or E  
If C, then either F or G  
So If A, then either D or E or F or G

Note, that in the case of IBT 'then' should be conceived in a temporal sense while in the case of TEGS 'then' signifies logical implication.

### Some remarks on additional expressions of temporal logics

As it is well known, temporal logics are usually considered as extensions of modal logics which operate on temporal expressions of the ordinary language: Prior's system is an early example (Prior 1957). In our days, the main disciplines studying temporal questions are AI and Computer Science which have adopted the modal and linguistic conception of temporal logic (note that Prior's original expression was 'tense logic' which directly refers to a linguistic approach). In this paper I tried to show that some apparent temporal expressions of natural languages can be substituted with timeless (logical) expressions or, more precisely, temporal diagrammatizations could be substituted with atemporal ones. In spite of the fact that many so-called temporal expressions could have been analysed (for example: 'until', 'eventually', 'unless', 'at the next moment', 'precedes' see LAMPORT 1980, JOSKO 1987) we will concentrate here only two of them, namely 'always' and 'never'.

Note that, in the case of temporal logics, originally timeless expressions like 'always' are usually analyzed as they occur in time. For example, expressions like  $\langle \Box p \rangle$  that means 'p is true throughout every possible future' or 'p was, is and will be true forever' suggest a temporal interpretation of being always true. But I think these interpretations misunderstand the logical structure of originally atemporal expressions since the word 'always' simply states logical inclusion between individuals, concepts, propositions or functors. Consider the following examples.

- a. Peter will always be a human.
- b. Romeo will always love Juliet.
- c. 2 will always be an even number.

Its easy to see that none of these statements express temporality, since they could be transcribed as follows.

- a'. Being Peter entails being human.
- b'. Being Romeo entails loving Juliet.
- c'. The concept of '2' entails being an even number.

The situation is slightly different when inclusion applies to functors as in the case of d.

- d. A bachelor will always be unmarried.
- d'. The functor 'x is a bachelor' entails the functor 'x is unmarried'.

Inclusion is far more apparent in the case of functors since the sentence 'A bachelor will always be unmarried' could be transcribed as 'All bachelors are unmarried', and it is well known that this latter expression doesn't express a statement on  $\langle \text{all bachelors} \rangle$ , but it expresses that  $\langle \text{if } x \text{ is a bachelor then } x \text{ is unmarried} \rangle$ . So 'always' should be analyzed so much as 'all'. Then, for example, the sentence 'Romeo will always love Juliet' does not express a temporal statement that Romeo will love Juliet tomorrow, the day after tomorrow etc. but it states that if someone is Romeo then he loves Juliet:  $\langle \forall x \rangle \langle Fx \supset Gx \rangle$

In the same way, we don't have to refer to temporality as regards expressions contains the word 'never' because the point is that, logically, 'never' refers to disjunctive individuals, propositions, concepts or functors.

- a. Peter will never be a spider.
  - b. Romeo will never love a dinosaur.
  - c. 2 will never be an odd number.
  - d. A bachelor will never be a bigamist.
- a' 'Being Peter' and 'being a spider' are disjuncts.
  - b' 'Being Romeo' and 'loving a dinosaur' are disjuncts.
  - c' The concept '2' and the concept of 'odd number' are disjuncts.
  - d' The functor 'x is a bachelor' and the functor 'x is a bigamist' are disjuncts.

Fig 19. shows some TEGS representations of 'always' and 'never'.

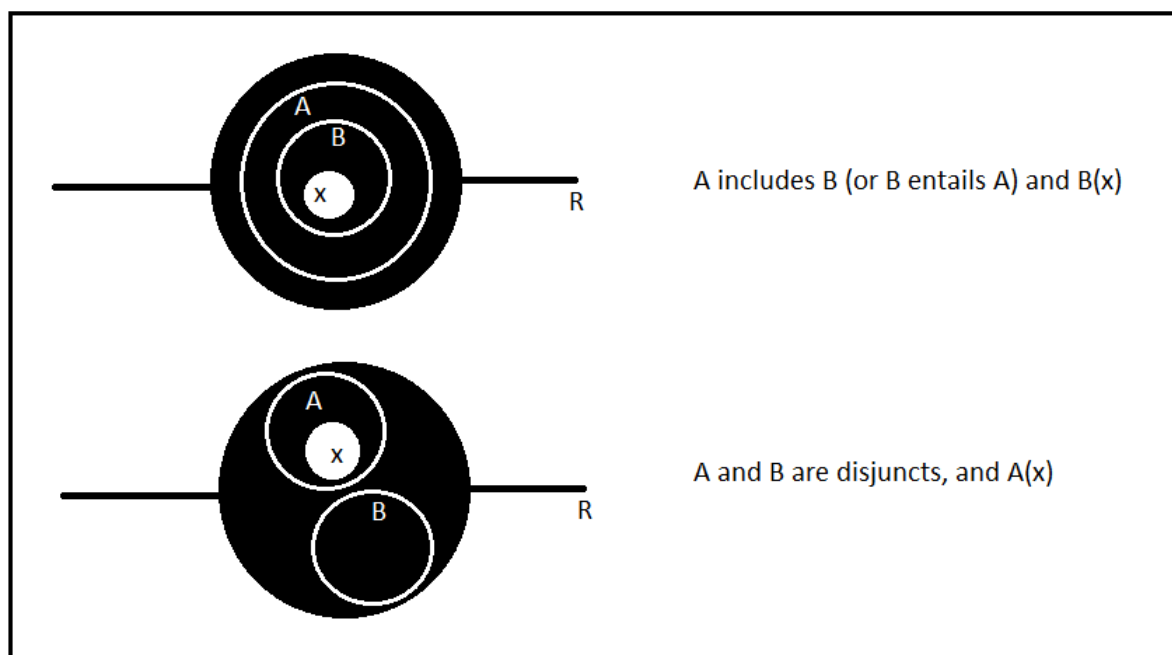

Fig 19.

### Concluding remarks

At first sight, reversibility presupposes temporality, but I hope that I could show that logical types and their relations are atemporal. So reversibility and irreversibility are irrelevant categories as regards logical types. Nevertheless, exemplars and their relations are subject of change; but the possibility of these changes are preordained by the logical types they could be

occurred in. In a few words, the boundary conditions of any possible change are always atemporal type-relations. Pseudo-temporal expressions like 'always' and 'never' could be transcribed as expressions with atemporal structure. The idea of 'reversible process' is not a temporal, but a logical idea which refers to symmetric structures. In other words: notations could be mirrored as long as they are symmetrical. Logically symmetrical structures are primarily conjunction, disjunction and exclusive disjunction (Fig 20.)

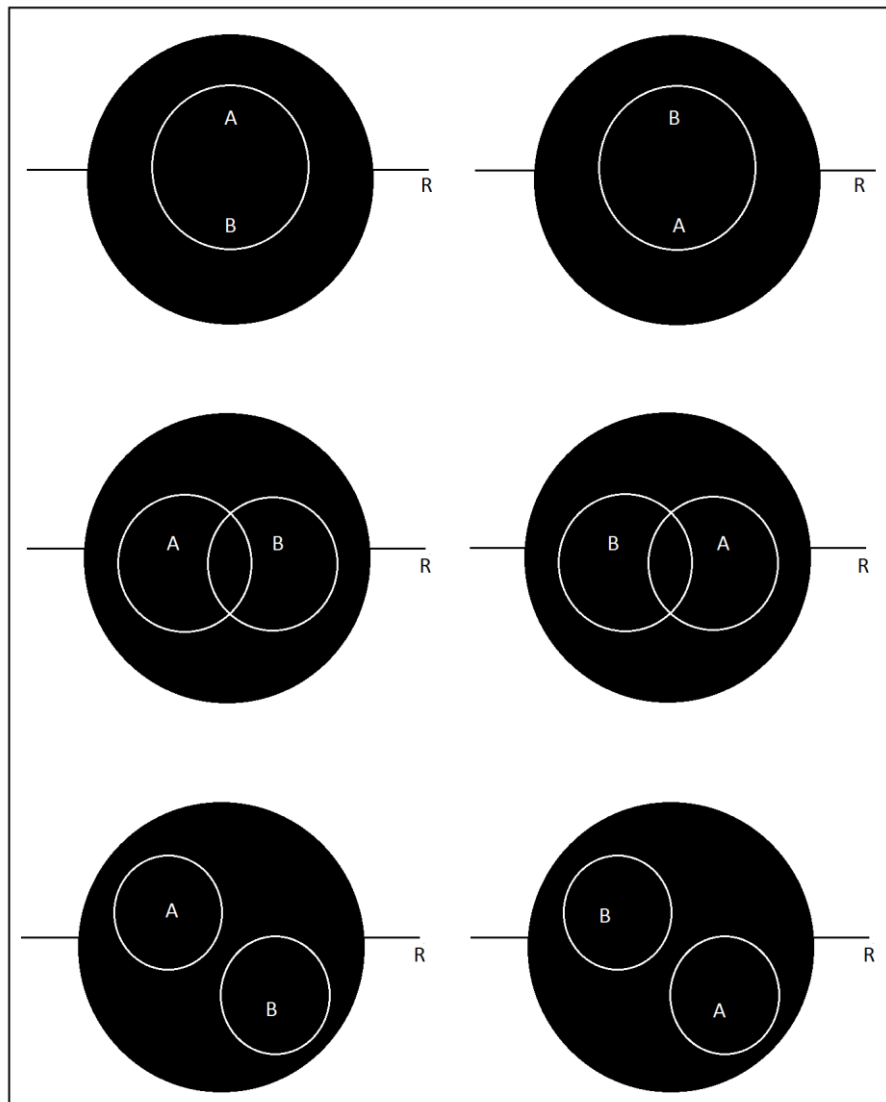

Fig 20.

As for communication, we could now express three considerations. First, communication (as an event, process or action) could not be reversed. Second, the type of a given communication could be structurally symmetric (which does not mean that it is reversible). And third, the possibility of a given communication is *a priori* to its individual occurrence. Let Wittgenstein's Tractatus re-emerge: *«In der Logik ist nichts zufällig: Wenn das Ding im Sachverhalt vorkommen kann, son muß die Möglichkeit des Sachverhaltes im Ding bereits präjudiziert sein»*<sup>6</sup>. (Wittgenstein 1921:2.012).

<sup>6</sup> Translated by D. F. Pears and B. F. McGuinness as „In logic nothing is accidental: if a thing *can* occur in a state of affairs, the possibility of the state of affairs must be written into the thing itself” Wittgenstein 2001: 2.012.

## References

- Ben-Ari, M.; Pnueli, A.; Manna, Z.: 1981, 'The Temporal Logic of Branching Time', *Proc. 8th ACM Syrup. on Principles of Programming Languages*, 1981, pp. 164-176.
- Benthem, J. F. A. K. van: 1983, *The Logic of Time*, London
- Burgess, J. P.: 1980, 'Decidability for Branching Time', *Studia Logica*, p. 203ff.
- Fisher, M (2011): *An Introduction to Practical Formal Methods Using Temporal Logic*. John Wiley & Sons.
- Galton, Antony (editor): 1987, *Temporal Logics and Their Applications*. Academic Press, London.
- Goos, G. – Hartmanis, J. (eds); 1987, *Temporal Logic in Specification*. Springer Verlag.
- Greiner, W. – Brendt, M.; 1994: *Quantum Mechanics. Symmetries*. 2nd ed., Springer.
- Josko, Bertrand: MCTL - AN Extension of CTL for Modular Verification of Concurrent Systems in Goos, G. – Hartmanis, J. (eds); 1987, *Temporal Logic in Specification*. Springer Verlag.
- Lamport, L. (1980): '„Sometime” is sometimes „not never”: on the temporal logic of programs.' *Proceedings of the 7th ACM Symp. on Principles of Programming Languages*, pp. 174-185.
- McDermott, D.: 1982, 'A Temporal Logic for Reasoning about Processes and Plans', *Cognitive Science* 6, pp. 101-55.
- Nishimura, Hirokazu: 1979, 'Is the Semantics of Branching Structures Adequate for Non-metric Ockhamist Tense Logics', *Journal of Philosophical Logic* 8, pp. 477-478.
- Ohrstrom, Peter – Hasle, Per F.V.: 1995, *Temporal Logic. From Ancient Ideas to Artificial Intelligence*. Kluwer Academic Publishers, Dordrecht, Boston, London.
- Prior, A. N., 1957, *Time and Modality*, Oxford: Clarendon Press.
- Prior, A. N.: 1967, *Past, Present and Future*, Oxford: Clarendon Press.
- Rescher, N. – Urquhart, A.: 1971: *Temporal Logic*. Springer-Verlag, Wien – N.Y..
- Sachs, R. G.: 1987: *The Physics of Time Reversal*. University of Chicago Press.
- Stirling, Colin: Comparing Linear and Branching Time Temporal Logics in Goos, G. – Hartmanis, J. (eds); 1987, *Temporal Logic in Specification*. Springer Verlag.
- Sun-Joo Shin: *The Logical Status of Diagrams*. Cambridge University Press, 1994, 2006.
- Wille, R. – Drechsler, R.: 2010: *Towards a Design Flow for Reversible Logic*. Springer.
- Wittgenstein, Ludwig (1921): *Logisch-Philosophische Abhandlung. Annalen der Naturphilosophie, Band 14, 1921, S. 185–262*.
- Wittgenstein, Ludwig, 2001. *Tractatus Logico-Philosophicus*. Routledge Classics, 2001.
- Wolper, Pierre: On the Relation of Programs and Computations to Models of Temporal Logic in Goos, G. – Hartmanis, J. (eds); 1987, *Temporal Logic in Specification*. Springer Verlag.
- Wright, Georg Henrik von, 1963. *Norm and Action. A logical Enquiry*. Routledge – Kegan Paul, London. .