

Development of Cement Bonded Composite Beams

László BEJÓ* – Péter TAKÁTS – Norbert VASS

Institute of Wood and Paper Technology, University of West Hungary, Sopron, Hungary

Abstract – The paper reports on the early steps in the development of cement bonded composite beams. The advantage of such products is that they are lighter than reinforced concrete, while more fire-resistant than solid wood or traditional composite beams. Experimental beams were produced to imitate the structure of organic bonded PSL and LSL, using poplar veneer strips and Scots pine strands. In this phase of the research, the aim was to verify that such products are feasible, compare different beam types, and determine the focus for the ongoing development of cement-bonded composite beams.

The manufactured beams were found to be fairly lightweight, but their mechanical properties were lower than those of solid wood or composite beams. PSL type beams performed better than cement-bonded LSL. Problem areas that caused the relatively poor performance were identified. Further experimental work will be directed at improving the mechanical performance of the beams.

cement bonded wood composites / composite beams / non-destructive testing

Kivonat – A cement-kötésű kompozit gerendák kifejlesztésének kezdeti lépései. Ezen újságcikk a cementkötésű kompozit gerendák kifejlesztésére tett első kísérleteket mutatja be. E termékek előnye, hogy könnyebbek a vasbetonnál, azonban tűzállóbbak a tömörfánál és a hagyományos kompozit gerendáknál. A szerves kötésű PSL és LSL termékekhez hasonló szerkezetű kísérleti gerendák nyár furnércsíkokból, illetve erdei fenyő strand-ekből készültek. A kutatás jelenlegi szakaszának a célja az ilyen termékek kivitelezhetőségének ellenőrzése, a különböző gerendafajták összehasonlítása és a cementkötésű kompozit gerendák további fejlesztési irányának meghatározása volt.

Az elkészült termékek önsúlya viszonylag alacsony volt, azonban mechanikai tulajdonságai elmaradtak a tömörfától vagy más kompozit gerendaféleségektől. A PSL jellegű tartók nagyobb szilárdságúak lettek az LSL típusúaknál. A kutatás következő szakaszának célja az új termék mechanikai tulajdonságainak javítása bizonyos gyártástechnológiai problémák megoldása által.

cementkötésű fakompozitok / kompozit gerendák / roncsolásmentes vizsgálatok

1 INTRODUCTION

Recent years brought a renewed interest in wood-based construction in many European countries. Despite the manifold advantages, structural application of natural wood and wood based composites represent certain challenges. The biggest problem is the typical and not always groundless classification of wood as a flammable material (Wood Handbook 1999).

* Corresponding author: lbejo@fmk.nyme.hu; H-9401 SOPRON, Pf. 132

Wood based composites, too, are usually considered as combustible materials releasing toxic fumes when burning.

Inorganic building materials like stone, brick and concrete have high compression strength. One problem is that their tensile strength, and consequently, their bending strength, is very low. In the antiquity, this problem was handled by densely spaced columns, later by using arches. A serious breakthrough came with the invention of steel-reinforced concrete. In this structure, steel components resist tensile, flexural loads and shear, while concrete prevents compressive failure and buckling, and provides protection against corrosion.

While reinforced concrete is a “tried and true” material, one should note some disadvantages. Both steel and concrete have high density, thus their combination will be heavy as well. Also, the mineral resources of our world are not endless, and neither steel nor concrete are renewable materials. The possibility of creating new, lighter and more environment friendly load-bearing structures should be therefore investigated.

Engineered wood-based composite beams are relatively new products. Until recently, lightframe construction used solid wood only. Even though its development for commercial use started in 1967 (Kunesh 1978) it was not until the 80’s that LVL, the first engineered composite beam, entered the commercial market. LSL and PSL are even newer than that. The latter two composite types are true value-added products; they incorporate low-quality wood components – veneer strips and strands – to yield high-strength composite beam products (Wood Handbook 1999).

Inorganic bonded wood composites have been developed at the end of the 19th century (Kossatz et al. 1983, Winkler 1998). There are many different composite types, and their characteristics are much varied (Simatupang – Lange 1992). Even though their mechanical properties are typically low due to the lack of chemical bonds between the wood and the inorganic binder, they have several advantages. One is the superior fire resistance. Some high-density products have reached the A₂ fire-resistance class (non-flammable) according to DIN 4102 (Takats 1998). Inorganic bonded composite materials are typically produced as panel products or building blocks of various densities. There seems to be little indication in the literature that they have ever been considered as one-dimensional load-bearing elements (columns or beams).

Our research project is aimed at creating a composite beam from wood and cement. The goal is to produce beams that present a feasible compromise between the seemingly contradicting requirements of high strength, low weight, renewability and fire resistance. The technology and experience for producing inorganic-bonded wood composites, wood-based composite beams and concrete beams reinforced to resist tensile and flexural loads are already in place. In this project we attempt to combine these in a single product: the cement bonded wood composite beam.

The present article describes the first steps in the project. The objectives for this phase of the research were the following:

- manufacturing a limited number of beams of different structures and densities to verify that such products are feasible,
- comparing different types of wood constituents to establish what constituent geometry is better suited for such composites,
- determining the focus for the ongoing development of cement-bonded composite beams.

The weakest link in the fibre-matrix system is the interface between the cement matrix and the woody constituents. In wood-cement composite systems there is no chemical bond between the components. There is a physical connection between the wood and the cement mix. Fibre-cement interface testing is rarely done, because of technical difficulties in mounting the specimens on the test blocks.

Figure 1 shows the fracture surface of a cement bonded chipboard specimen. It confirms that the interface is indeed the weakest part of the system. Fracture occurs either in the matrix or at the interface. Even though this image was taken after a bending test, it is safe to assume that the same would happen in shear or internal bond tests. For this reason, our research did not include fibre-matrix interface testing.

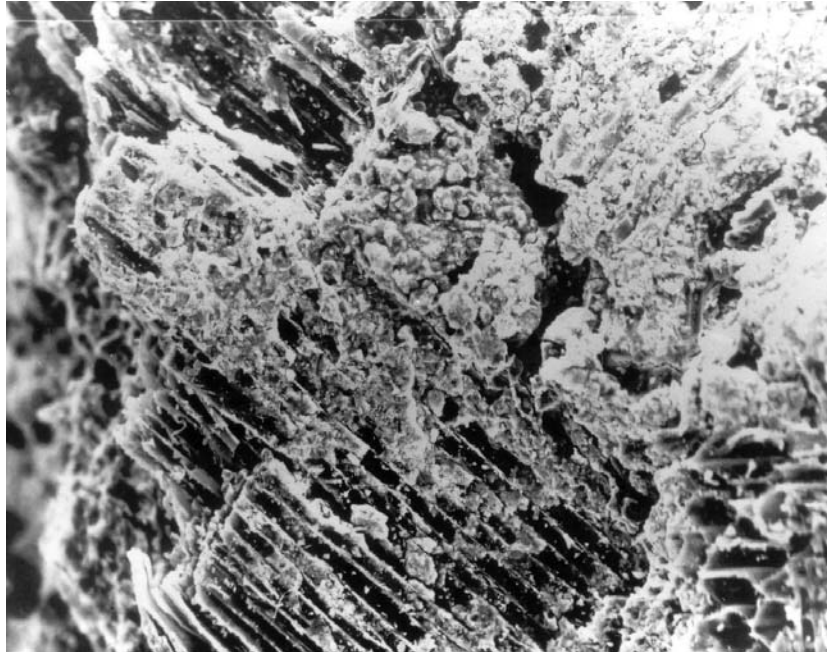

Figure 1. Scanning electromicroscopic image of the fibre-matrix interface (Takáts 2002)

2 MATERIALS AND METHODS

2.1 Composite beam manufacture

Experimentation included two basic composite beam structures: PSL type beams made of veneer strips and LSL type beams composed of strands. Both beam types were manufactured to two different target density values of 800 and 1100 kg/m³. For easier reference, the four beam types were named PSL800, PSL1100, LSL800 and LSL1100, respectively.

Raw material of the PSL type beams included 0.6 m long, 10mm wide and 3 mm thick poplar (*Populus x euramericana cv. I-214*) veneer strips. LSL type beams were made of standard Scots pine (*Pinus silvestris*) OSB face strands originating from KRONOSPAN Poland. Figure 2 demonstrates the shape and dimensions of the strands. We chose the above wood species because they, unlike many other species, do not contain chemical constituents that inhibit cement curing (Takáts 1998). We used high-strength Portland cement as a matrix material, with calciumchloride-dihydrate (CaCl₂ + H₂O) accelerator.

The mix was prepared using a 0.18 wood-cement ratio and a 0.4 water-cement ratio in all cases. Veneer and strand moisture content was estimated at 6%, according to the environment in which they had been kept for several weeks, and was accounted for when adding water. The amount of CaCl₂ additive was 3% of the amount of concrete, based on mass. The same mixture was used for the 800 and 1100 kg/m³ beams. The total of six beams produced included two pieces of both LSL800 and LSL1100, and one piece of both PSL800 and PSL1100.

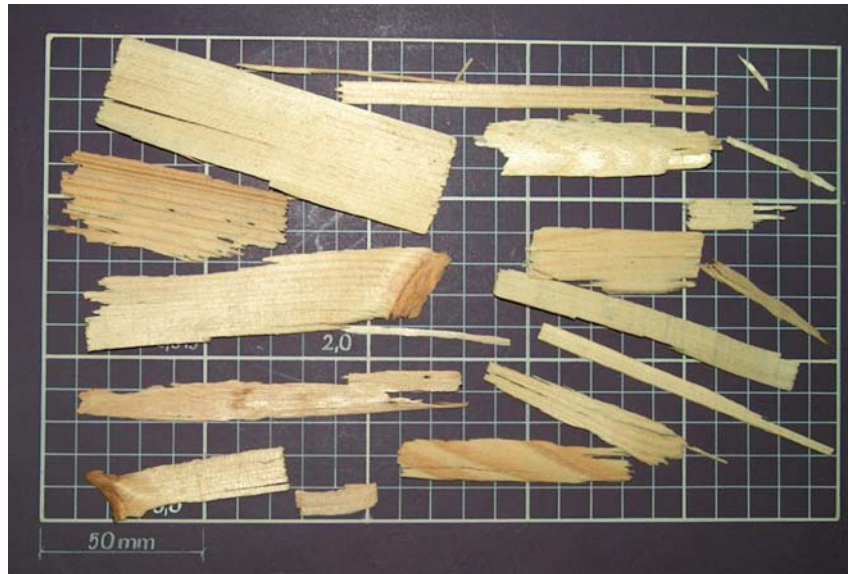

Figure 2. OSB strands used for the LSL type beams

The six forming boxes were made of 30 mm thick MDF boards. Figure 3 shows the structure of the formwork. The height of the sidewalls was twice that of the beam, to house the forming web of the top piece designed to densify the material. According to the setup shown on Figure 3, final beam dimensions were 2 m x 0.1 m x 0.06 m.

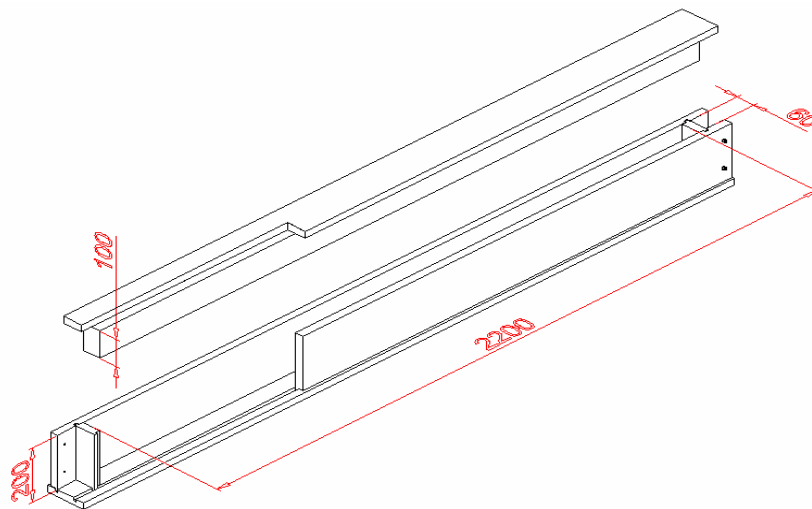

Figure 3. Formwork configuration and dimensions

Beam manufacture started by mixing strands and veneer strips with the required amount of water and CaCl_2 . This procedure allowed the wood components to take up most of the water necessary for cement cure, and gradually release it back into the matrix throughout the cure period. Unfortunately, thick veneer strips used for the PSL type product could not take up all of the water, which caused some of the hydrated cement to cluster, rather than covering the strips evenly, as happened in the case of LSL strands.

The next step was manually filling the mixture into the formwork. LSL strands were oriented using a funnel-like apparatus (Figure 4), while longer veneer strips aligned themselves well. Special care was taken to distribute the strands evenly along the length of the beam. For this reason, some veneer strips were broken to fill the ends of the PSL type beams. After filling the formwork, the mix was manually pre-pressed.



Figure 4. Aligning the strands in LSL type composites

The beams contained in their formworks were then placed into a standard single-daylight hot press. The press was closed and enough pressure applied so that the gap between the top and side pieces was closed completely. The press remained closed for the next 24 hours. Press platen heating was turned off during pressure application. After 24 hours the beams were removed from the hot press, and stored in an indoor environment ($T = 21^{\circ}\text{C}$, 50% R.H.) for a further 27 days.

2.2 Beam testing

Beam testing included non-destructive evaluation of the Young modulus using free longitudinal vibrations, and static bending tests. For non-destructive testing we used a measurement setup developed at the Non-destructive Testing Laboratory, UWH (Divos 2002). The basic principle of the test is the well-known fact that the stress-wave velocity of any material depends on the modulus of elasticity.

Figure 5 shows the test setup. Test pieces were supported at both ends. One end rested on a digital scale that measured the half-mass of the specimen. One end of the specimen was hit by a hammer, while a sensitive microphone picked up the vibration signal on the other end. Both the scale and the microphone were connected to a laptop computer that evaluated the data and – using the previously entered dimensional values – computed the stress-wave velocity, density and dynamic MOE. (Further details regarding stress-wave MOE determination may be found in Pellerin and Ross 2002.)

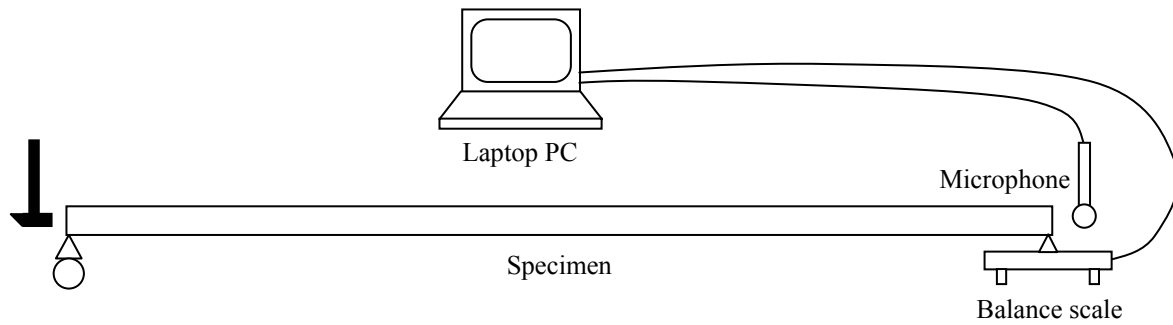

Figure 5. Dynamic MOE measurement setup

A 10 kN capacity Heckert FPZ 100/1 type universal screw-driven testing machine was used for the static bending tests. A three-point test setup was used for the measurements, with a crosshead speed of 5 mm/min that brought the beams to destruction in approximately sixty seconds. The testing machine recorded the load-deflection curves on paper. Deflection values were estimated by the cross-head displacement. The above practices were in accordance with an earlier Hungarian standard.¹

The cross-head penetrates into the material, as well as causing deflection, which decreases the measured MOE value. This penetration was fairly excessive in our case. Shear deformation that occurs when using the 3-point measurements also resulted in an underestimation of the MOE value. Because of the above, the MOE values reported in this article should be considered as apparent, approximate values only. MOR values, however, are accurate.

3 RESULTS AND DISCUSSION

Figure 6 shows the finished PSL and LSL type specimens. Cement clumping described in the previous section is clearly visible in the picture. Because of the larger cross section and higher stiffness of the veneer strips, the structure of the PSL type beams is less uniform, and contains more gaps. (This is true for organic-bonded PSL, too.) Table 1 summarises the measured density, static and dynamic mechanical properties of the beams.

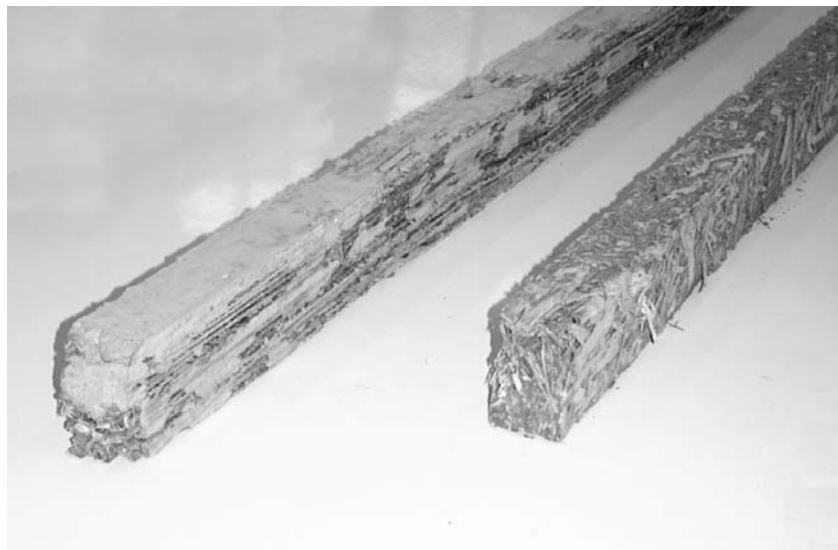

Figure 6. LSL (left) and PSL (right) cement bonded beams. Cement clumping is visible

¹ The European Standard EN 408:2003 describes the bending tests to be used for structural wood beams. Due to our limited means, our tests did not follow the specifications of this standard.

Table 1. Physical and mechanical properties of the beams

Beams	Density (kg/m ³)	MOR (MPa)	Static MOE (MPa)	Dynamic MOE (MPa)
LSL800 / 1	800	0.62	506	3 700
LSL800 / 2	780	1.34	1 123	1 150
LSL1100 / 1	1 140	5.74	2 699	5 600
LSL1100 / 2	1 100	3.44	2 218	5 500
PSL800	750	5.70	2 826	4 600
PSL1100	1 110	13.22	4 728	9 300

Lower density beams had consistently lower mechanical properties than those of the higher density ones. PSL performed better than LSL, but the values are still fairly low when compared to the strength and elastic properties of either solid wood or organic bonded composite beams (Table 2).

Table 2. Physical and mechanical properties of the raw material and of traditional composite beams

Wood species / composite beam type	Average density (kg/m ³)	MOR (MPa)	MOE (MPa)
Scots pine ¹	520	80	12 000
Poplar (clone 'I-214') ¹	320	58	5 330
Aspen LVL ²	566	62	8 960
Yellow-poplar PSL ²	673	73	13 800

¹ Source: Molnár and Bariska 2002

² Source: Bejo and Láng 2004

In most cases, dynamic MOE was roughly twice as high as the static value. This is partly due to the viscoelastic nature of the wood components, which makes the dynamically determined MOE roughly 10% higher than the static Young's modulus for solid wood (Divos – Tanaka 2000). The previously described inaccuracies, inherent to the measurement method, caused further discrepancies. In spite of these problems, the reasonably good correlation between dynamic and static MOE ($r^2 = 0.77$) gives some indication that vibration testing may be applicable to these composite beam types.

The superior strength of the PSL type beams is probably due to the length of the veneer strips. The length of the components is important, because, in cement bonded wood composites, there is no chemical bonding between the matrix and the fibre. Their integrity depends largely on the bonding surface. Long veneer strips are much harder to pull out of the matrix, than short strands. The longitudinal orientation of veneer strips was also much better than that of the shorter strand elements. Therefore, in spite of some manufacturing issues, like uneven cement distribution and structure, these beams proved to be much stronger than the LSL type beams.

The reason for the lower mechanical properties of the LSL type beams is mainly due to the short wood components that pulled out of the matrix relatively easily, and their alignment was less accurate than that of PSL veneer strips. There seems to be little room for improvement, therefore the concept of this beam type seems to be a cul-de-sac.

The positive correlation between beam density and mechanical properties was expected. Higher beam density was achieved through higher pressures during manufacture, which resulted in wood densification, elimination of gaps and improved connection between the matrix and the fibre. All of these contribute to the improved strength and stiffness.

3 SUMMARY AND CONCLUSIONS

Six experimental beams of various densities and composition were manufactured and tested for their mechanical properties, to assess the viability of cement-bonded composite beams for construction use. Of the two varieties, the PSL type beam performed better, and will be the basis of further product development. The load-bearing capacity of the composites was worse than that of solid wood. Further experimental work will be directed at improving the mechanical performance of the beams by solving some manufacturing issues that have been identified as problem areas. This will include:

- *Soaking veneer strips prior to mixing.* This way strips will contain the moisture needed for cement cure, and release it gradually into the matrix. This will prevent cement clumping and provide a more uniform structure.
- *Curing beams in a high humidity environment* would lead to better curing, as the moisture will be supplied by the atmosphere rather than the wood. This would decrease shrinkage that may sever the connection between the wood and the matrix during curing.
- *Using different wood component geometries*, namely, thinner and longer strips. These will take up water readily and resist being pulled out of the matrix.
- *Mixing strands and strips in the same product* might have advantages. The former can make the product stronger, while the latter fills in the gaps inherent to PSL geometry.

Acknowledgements: The authors express their thankfulness to Interspan Hungary and Heraklith Ltd. for their respective help in providing the strands and the cement needed for the experiments. Gratitude is also extended to Dr. Ferenc Divos at the Non-destructive Testing Laboratory and Szabolcs Csikos at the Institute of Applied Mechanics, UWH, for their help in beam testing. This research was partly funded by the Hungarian National Research and Development Programs (NKFP) research grant nr. 4/19/2001 (Forest-Wood Programme).

REFERENCES

- BEJO, L. – LÁNG, E.M. (2004): Simulation based modeling of the elastic properties of structural composite lumber. *Wood Fiber Sci.* 36 (3): 295-410.
- DIN 4102 Teil 1. 1981. Brandverhalten von Baustoffen und Bauteilen; Baustoffe; Begriffe, Anforderungen und Prüfungen. Beuth Verlag GmbH, Berlin. 15 p.
- DIVÓS, F. (2002): Portable lumber grader. In: Beall, F.C. (ed.): Proc. 13th Int. Symp. on Nondestructive Testing of Wood. Berkely, CA. August 19-21: 335.
- DIVÓS, F. – TANAKA, T. (2000): Effects of creep on modulus of elasticity determination of wood. *J. Vibration Acoustics - Transactions ASME* 122 (1): 89-92.
- EN 408:2003. Timber structures – Test methods – Solid timber and glued laminated timber – Determination of some physical and mechanical properties. CEN, Bruxelles, Belgium.
- FOREST PRODUCTS LABORATORY (1999): Wood handbook: wood as an engineering material. Washington DC: U.S. Department of Agriculture.

- KOSSATZ, G. – LEMPFER, K. – SATTLER, H. (1983): Anorganisch gebundene Holzwerkstoffplatten. Geschäftsbericht der Europäischen Föderation der Verbände der Spanplatten und anderer Werkstoffe. 98-108.
- KUNESH, R.H. (1978): MICRO = LAM: structural laminated veneer lumber. Forest Prod. J. 28(7): 41-44.
- MOLNÁR, S. – BARISKA, M. (2002). Magyarország ipari fái – Wood species of Hungary. Szaktudás Kiadó Ház, Budapest. 210 p. (bilingual)
- PELLERIN, R. F. – ROSS, R. J.: Transverse vibration and longitudinal stress wave nondestructive evaluation methods. In: Pellerin, R.F. – Ross, R.J. (eds.): Nondestructive evaluation of wood. Forest Products Society, Madison, WI. 13-37.
- SIMATUPANG, M.H. – LANGE, H. (1992): Herstellung und Anwendung mineralisch gebundener Holzwerkstoffe (1). Holz Zentralblatt 118 (20): 324-326.
- TAKÁTS, P. (1998). Szervetlen kötésű fa- és rost kompozitok. [Inorganic bonded wood and fibre composites]. Lecture Notes, University of Sopron. 109 p. (in Hungarian)
- WINKLER, A. (1998). Faforgácslapok [Chipboards]. Dinasztia Kiadó, Budapest. 183 p. (in Hungarian)