

Assessment of Quality-related Risks by the Use of Complex Networks

Tamás CSISZÉR*

Cziráki József Doctoral School of Wood Science and Technology, University of West Hungary, Sopron, Hungary

Abstract – This study introduces the NTS network as a new way of analysing, verifying and improving quality-related risk assessment. NTS is based on a network science approach that models complex systems by graphs. By using *N*, *T* and *S-Graphs* as the elements of NTS, risk events that play special role in the risk management system can be identified. Based on their characteristics, the strength of their potential causal connections can be recalculated, providing more precise predictions of the occurrence frequencies of events.

network science / risk assessment / optimization / FMEA / NTS graphs

Kivonat – Minőségi kockázatok elemzése komplex hálózatok segítségével. A tanulmány bemutatja a minőségügyi kockázatok közötti kapcsolatok elemzésére használható NTS hálózatot, amelynek segítségével - a kockázati események valós előfordulása alapján - értékelhetők és javíthatók a minőségi kockázatok elemzésének eredményei. Az NTS alkalmazása a hálózattudomány újszerű megközelítésén alapul, amely gráfok segítségével modellezi a komplex rendszereket. Az NTS elemeinek, az ún. *N*-, *T*- és *S*-gráfoknak a használatával azonosíthatók azok a kockázati események, amelyek speciális szerepet játszanak a kockázatmenedzsment rendszerben. Ismerve a jellegzetességeiket, az események közötti potenciális okozati kapcsolatok újraértékelhetők, amelynek eredményeképpen megbízhatóbb előrejelzés adható az egyes események előfordulási gyakoriságára.

hálózattudomány / kockázatelemzés / optimalizálás / FMEA / NTS gráfok

1 INTRODUCTION

Quality-related risk assessment aims to identify, analyze and prioritize events that may cause quality problems of products and processes. Experts try to evaluate the probability and effect of risks prior to the implementation of a new process and to the manufacturing of a new product. There might be cause-effect connections among ‘risk events’. Therefore, to ensure the proper performance of risk assessment, we must handle them as elements of a complex system, and take their connections into consideration as well.

There are many ways of modelling and analyzing complex systems. One of the emerging toolsets is coming from the field of network science. It structures systems in graphs, emphasizing the connectivity that forms the network and influences its characteristics. By

* Corresponding author: csisztam@gmail.com; H-2120 DUNAKESZI, Kazinczy u. 6a

representing risk events with vertices and their causal connections with edges, we construct a risk-network, with which a deeper insight into the structure of potential problems can be obtained, and more analyses can be conducted in order to validate and improve the output of the risk assessment.

Since there may be many difficulties with the raw material and manufacturing conditions in industrial technology, a new approach of risk assessment can be relevant and useful for researchers and engineers as well.

In the followings we briefly introduce network science basics related to the topic of this article, define and describe the NTS network as a new tool in risk assessment, and finally demonstrate how this method can be utilized and what kind of conclusions can be drawn based upon it.

2 BRIEFLY ABOUT NETWORK SCIENCE

Network science deals with complex systems. It models and analyzes these systems by graphs. The main purposes are to identify and define network models that are independent from the entities of the system, describe the characteristics of the networks, and give predictions to the reaction of the system to different influences, like modifying the number of vertices or the weights of the edges.

Networks can be featured by certain attributes. The degree of a node and the degree distribution of a network show how many edges are linked to the vertices and whether there are some nodes that are significantly 'richer' or more important than others (Newman 2003). By creating a graph, we can see whether it is a connected network or there are separated nodes or groups of nodes within the graph. This can be useful when we want to find the shortest or fastest path between two different parts of the system.

Vertices can have different roles according to their position. Some of them function as bridges, connecting two parts of the graph. Others are hubs with high degrees and centrality, and, as such, have huge effect on processes running in the network. There can be isolated nodes as well, with no links to others (Csermely 2005).

Networks are not static; many changes can be detected during their lifetime. A network starts when two or more entities create one or more connection among themselves. When a new node is introduced to the network, it gets connected to one or more original ones according to a network specific rule. One of the widely accepted theories defines this rule as the 'power law', where the probability of forming a connection is proportional to the degree of the original node. This has been modified by some other works implementing different variables. (Dorogovtsev 2000). The general principle is that the probability of connecting is proportional to the importance and some 'individual characteristics' of vertices.

Networks can be fragmented as well. When one or more links are eliminated due to some events, nodes or sub-graphs get separated from the network. This process can make the whole network unable to operate, i.e. to ensure the flow of information, material or other exchangeable among vertices.

Knowing the structure, the attributes and the operation rules of the network, we can deeply understand the given complex system. Thus we can establish a robust system that would be more protected from intentional or accidental problems.

3 QUALITY-RELATED RISK ASSESSMENT

3.1 Traditional approaches

Several methods exist that provide tools for quality-related risk assessment. One of the most widely spread ones is the Failure Modes and Effects Analysis (FMEA). This mainly qualitative method can be used to analyse the probability and the effect of potential failures associated with a process or a product.

The purpose of FMEA is to mitigate the risk by reducing either the severity, or the probability of an incident. First of all, potential failures need to be listed. For each one, three factors should be calculated: 1) probability, i.e. the likelihood of occurrence; 2) severity, i.e. the worst case scenario of negative effect; 3) detection, i.e. how easy it is to detect the problem during operation. The combination of factors is the risk level. Based on this level, preventive, detective and corrective actions can be defined (Stamatis 2003).

Another method called Fault Tree Analysis (FTA) builds a hierarchical structure of undesired events and their potential causes. It defines logical connections among causes by Boolean operators and calculates the probability of an event from the probabilities of causes (Andrews 2012).

Both FMEA and FTA are aimed at identifying and analysing potential problems and trying to reduce their negative effects. While FMEA is a deductive, top-down methodology, focusing on the effects of an initial event, FTA is an inductive, bottom-up method, considering the potential causes of a failure as an undesired effect. FMEA builds a cause-effect tree from the root; FTA builds the same tree from the crown. If we apply FMEA and FTA together, the result will be a complex system with negative events and the causal connections among them. This system could be modelled by a network that can handle the data of probabilities and logical relationships. In order to keep the risk assessment results updated during the operation, information of real occurrences needs to be handled too. By analysing this network regularly, the theoretical structure of potential failures and the performance of risk management can be improved.

3.2 Definition of the NTS network

NTS consists of failures or, in a broader sense, risk events as vertices and common occurrences or presumed causal connections among them as directed edges. Edges can be weighted according to the strength of connection between cause and effect. In the analysis phase, the weight of an edge is

$$S_{A_e, A_c} = P(A_c)P(A_e) \quad (1)$$

where S_{A_e, A_c} the weight or strength of an edge between A_c as the cause, and A_e as the effect, whilst P is the probability of the occurrence of an event. If there are several causes, the value of $P(A_c)$ is the combination of the probabilities of these causes ($A_{c1}, A_{c2} \dots A_{cn}$). There are two different cases:

- 1) events that can cause the effect only when they occur together;
 $A_{c1} \text{ AND } A_{c2} \Rightarrow P(A_c) = P(A_{c1})P(A_{c2});$
- 2) events that can cause the effect separately;
 $A_{c3} \text{ OR } A_{c4} \Rightarrow P(A_c) = P(A_{c3}) + P(A_{c4}).$

Figure 1 shows the graph representation of a simple system. A_{c1} and A_{c2} are represented together by one vertex in graph; A_{c3} , A_{c4} and A_e are separate vertices.

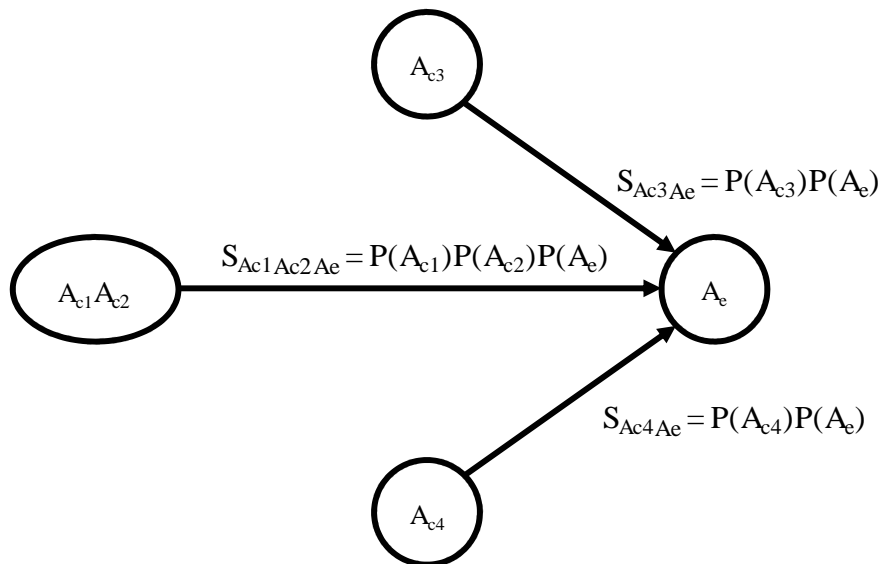

Figure 1: Graph representation of cause-effect connections of events

Since vertices $A_{c1}A_{c2}$, A_{c3} and A_{c4} are independent from each other,

$$P(A_e) = P(A_{c1}A_{c2}) + P(A_{c3}) + P(A_{c4}) \quad (2)$$

The weights of links can be calculated, as follows:

$$S_{Ac3Ae} = P(A_{c3})(P(A_{c1}A_{c2}) + P(A_{c3}) + P(A_{c4})) \quad (3)$$

$$S_{Ac1Ac2Ae} = P(A_{c1})P(A_{c2})(P(A_{c1}A_{c2}) + P(A_{c3}) + P(A_{c4})) \quad (4)$$

$$S_{Ac4Ae} = P(A_{c4})(P(A_{c1}A_{c2}) + P(A_{c3}) + P(A_{c4})) \quad (5)$$

This means that without knowing the probability of the occurrence of the final effect, we can calculate the weights of the links among a risk event and its potential causes.

3.3 The use of NTS

These weights are theoretical, since their calculation is based on prediction. If we want to validate these values, we have to calculate them based on data coming from the running process. There are two indicators that can be used to estimate the strength of connection (S) in the operational phase. The first one is the number of simultaneous occurrences (N), the other one is the time difference between the occurrences of cause and effect (T). The higher the N and the lower the T , the higher will be S . Consequently higher N/T ratios result in higher S values. T can be calculated as the average number of occurrences of common detections.

3.3.1 N-Graph

Let's assume that, from the analysis phase, we have a list of risk events related to the quality of a manufacturing process. When an event ($A1$) is detected, it has to be noted as a potential root cause. If, within a certain time period after $A1$, another event is detected, we record the time that passed between detections. Let this period be 4 seconds. The strength of the link between $A1$ and $A2$ is

$$S_{A1A2} = N/T = 1/4 = 0.25 \quad (6)$$

When a third event is detected e.g. 5 seconds after A2, the same calculation can be done. So, the strength of the link between A2 and A3 is

$$S_{A2A3} = N/T = 1/5 = 0.2 \tag{7}$$

Now we have a small connected group with three vertices and two edges. *Figure 2* shows the graph that represents this triplet.

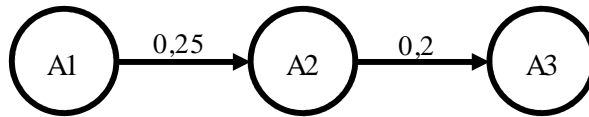

Figure 2: Graph representation of event connections with the weights of connections indicated above the edges

We do not know yet whether A1 or A2 or both together caused A3, we just know that there is a chance that the common occurrence may reflect a causal connection.

Let us assume that, two minutes later, A2 is detected again. Two conclusions are possible: 1) A3 caused A2, or 2) this is an independent occurrence. Based on the elapsed time and on professional experience, we can make a decision concerning the existence of a causal connection. If we think that there is no causal connection, or there can be, but the time is much longer than the time has passed between the former detections, we can take A2 as a first event of a new cause-effect chain. Obviously, if there is no significant lag between them, and a causal connection is possible, A3 may cause A2, so the link between them is bi-directional. Since 2 min is much longer than the previously detected durations, now A2 starts a new graph. Obviously, this does not mean that A3 could not have caused A2, since we have no evidence that A2 is certainly the reason of A3. Continuing this event monitoring and detection process, we can get short event-chains consisting of connected groups of vertices (*Figure 3*).

[N]

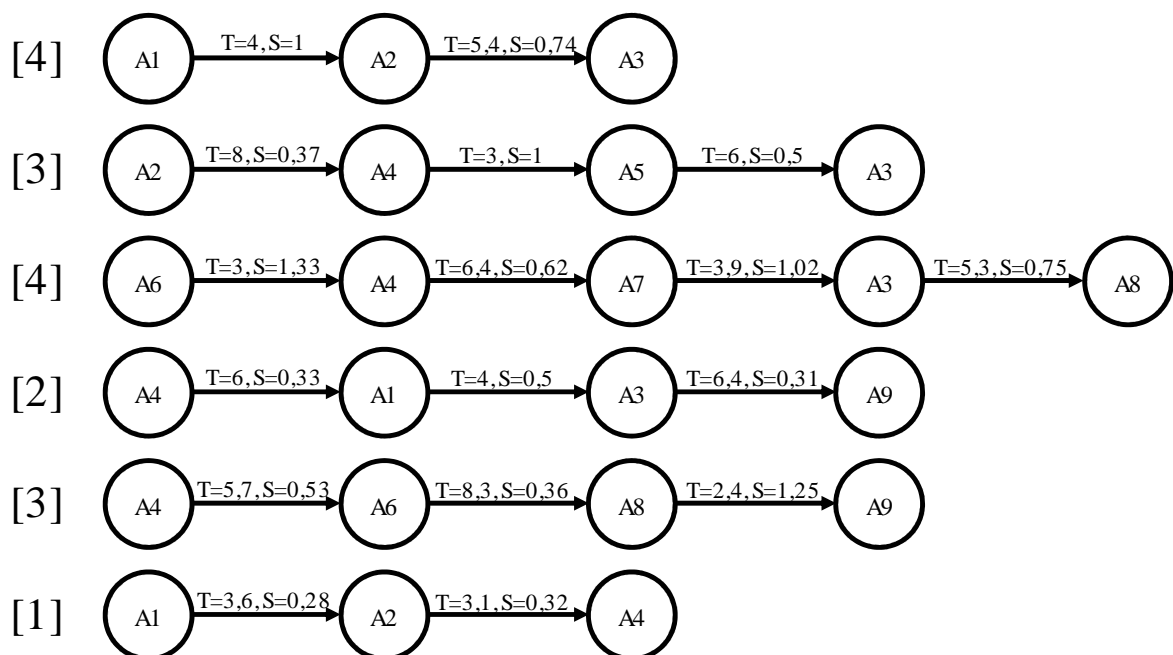

Figure 3: Event-chains with the attributes of links as follows: N (Nr. of common occurrences), T (average time between the occurrences of events), S (weight of edge).

In order to get a connected network from event-chains, we should merge them by using only one vertex for the same event. Since all of the attributes of the links (N , T , S) can reflect the strength of a causal connection, they can be used to create separate networks with N , T and S as the weights of edges.

The N -Graph (Figure 4) shows how frequently the events occurred together. The weight of the edge is reflected by the thickness of the arrow, the number on the arrow and the two-dimensional distance between the linked vertices.

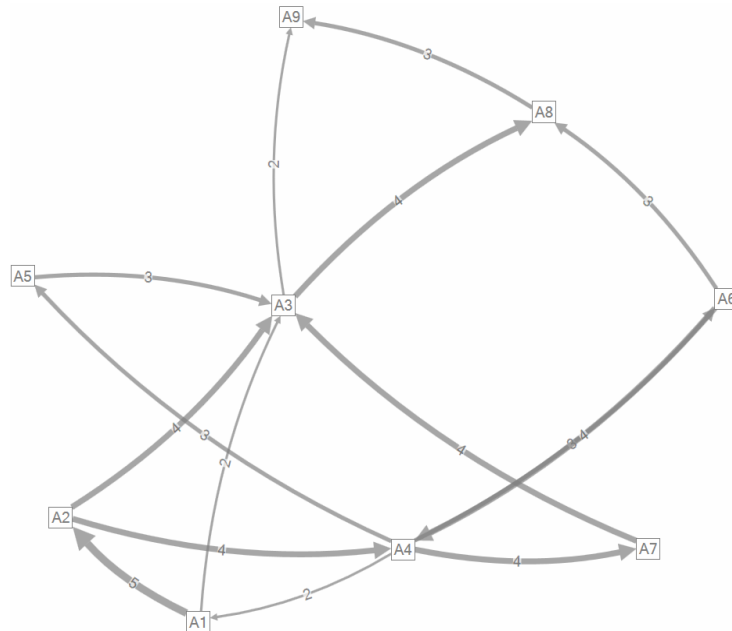

Figure 4: N -Graph

The degree parameters of vertices are listed in Table 1. The weights and the in- and out-connection ratios of edges are presented in Table 2.

Table 1. Degree parameters of vertices of the N -Graph

Vertex	Weighted in-degree	Weighted out-degree	Weighted degree
A1	2	7	9
A2	5	8	13
A3	13	6	19
A4	8	12	20
A5	3	3	6
A6	3	7	10
A7	4	4	8
A8	7	3	10
A9	5	0	5

Table 2. The weights and the out- and in-connection ratios of edges of the N-Graph

Vertex 1	Vertex 2	Weight	Out-connection frequency ratio ¹ (%)	In-connection frequency ratio ² (%)
A1	A2	5	71.4	100.0
A2	A3	4	50.0	30.8
A2	A4	4	50.0	50.0
A4	A5	3	25.0	100.0
A5	A3	3	100.0	23.1
A6	A4	4	57.1	50.0
A4	A7	4	33.3	100.0
A7	A3	4	100.0	30.8
A3	A8	4	66.7	57.1
A4	A1	2	16.7	100.0
A1	A3	2	28.6	15.4
A3	A9	2	33.3	40.0
A4	A6	3	25.0	100.0
A6	A8	3	42.9	42.9
A8	A9	3	100.0	60.0

1 – Weight of the current edge / weighted out-degree of Vertex 1 as the start node

2 – Weight of the current edge / weighted in-degree of Vertex 2 as the end node

The following main conclusions can be drawn from *N-Graph* and the associated tables:

- 1) Every event follows at least one other event (in-degree is never zero);
- 2) *A9* is not followed by any other event (its out-degree is zero);
- 3) *A3* and *A4* play central roles, since their weighted degrees are the highest;
- 4) The weighted in-degree of *A3* (13) is approx. twice as big as its out-degree, so *A3* tends to occur as a successor, rather than a predecessor;
- 5) Contrary to *A3*, for instance, *A4* tends to occur as a predecessor rather than a successor, since its out-degree is 12 and its in-degree is 8;
- 6) According to the out-degree frequency ratio of the *A5-A3* connection, when *A5* occurs (three-times), it always causes *A3*. In contrast, according to the out-degree frequency ratio of the *A5-A3* connection, *A3* is caused by *A5* in 3 cases, which is only 23,1% of all occurrences of *A3* (13).

Applying the *N-Graph*, we can come to the following general conclusions:

- 1) The higher the out- or in-degree frequency ratio of a connection, the higher the probability of their common occurrence;
- 2) If the in-degree of a vertex is higher than its out-degree, the event tends to be a successor of other events;
- 3) If the out-degree of a vertex is higher than its in-degree, the event tends to be a predecessor of other events;
- 4) If the in-degree of a vertex is zero, it starts an event-chain or its predecessors are unknown;
- 5) If the out-degree of a vertex is zero, it ends an event-chain or their successors are unknown;
- 6) Isolated vertices (both their in- and out-degrees are zero) have no connections with other events in the N-Graph.

3.3.2 T-Graph

The *T-Graph* (Figure 5) is created based on the time that passes between the occurrences of vertices. The shorter the time, the stronger the connection and the larger the weight of edge.

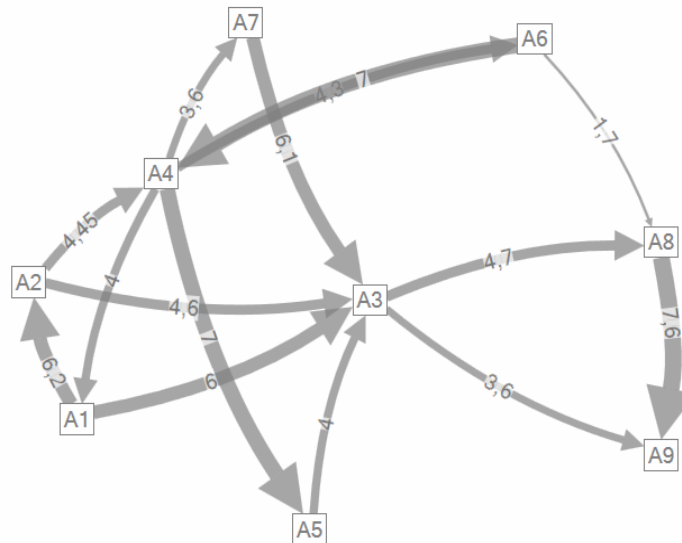

Figure 5: *T-Graph*

In the *T-Graph* we can identify the possible sequences of events. For example, if *A1* occurs, *A2* and/or *A3* are also likely to occur, approx. 6 seconds later. When *A3* occurs, we have to take appropriate measures in order to prevent the occurrence of *A8* and *A9*. From the *T-Graph*, we do not know what the probability of a successor's occurrence is.

3.3.3 S-Graph

The *S-Graph* (Figure 6) shows the relative probability of an event's occurrence after the occurrence of its predecessor has been detected. The relative probability is the weight of the edge between the predecessor and the successor, divided by the sum of the weights of the out-edges of the predecessor. For example, if we detect the occurrence of *A1*, the relative probability of the occurrence of *A2* is $4.8/(3.8 + 4.8) = 0.558$. The relative probability of the occurrence of *A3* is $3.8/(3.8 + 4.8) = 0.442$. This means that the occurrence of *A2* is more probable. Since *A2* can cause *A3* too, the relative probability of the occurrence after the detections of *A1* and *A2* is $(3.8/(3.8 + 4.8)) + ((4.8/(3.8 + 4.8))(5.6/(5.6 + 2.6))) = 0.442 + 0.558 \times 0.683 = 0.82$.

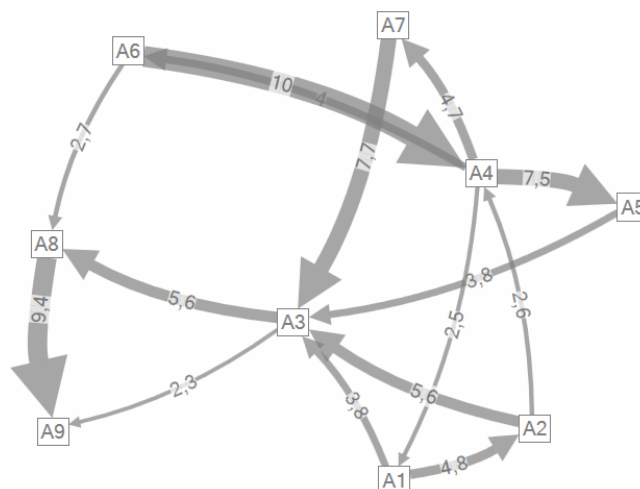

Figure 6: *S-Graph*

By calculating the relative probability of every possible event-chain, we can quantify the strength of connections and the chance that a failure occurs.

3.4 Conclusions

The N , T and S -*Graphs*, collectively named NTS, show the events that play specific roles in risk assessment. Based on the analysis of connectivity, we can verify and modify the results of risk assessment and we can create new risk management strategies and actions. Some of the general conclusions based on the NTS analysis are as follows:

- 1) The higher the S and the relative probability, the larger the probability of the existence of causal connection between vertices. This means that if this connection has not been identified formerly, preventive actions need to be defined and applied.
- 2) The larger the out-degree of a vertex in the N -*Graph*, the more important role the associated event plays as a possible cause of problem. This means that the risk management activities have to be focused on the prevention and detection of this event.
- 3) The bigger the in-degree of a vertex in the N -*Graph*, the more likely its occurrence is. This means that we have to count on its frequent occurrence, so the introduction of risk mitigation measures is strongly advised.
- 4) The lower the average time between the occurrences of two connected events in the T -*Graph*, the faster we have to react to prevent the occurrence of its successor. This means that we have to define actions that can be conducted in a very short time.

Finally, it is important to emphasise that NTS is only an approximation of the existence of a causal connection. In order to prove the causality, NTS and other professional investigation tools need to be applied on the long run.

REFERENCES

- ANDREWS, J. (2012): Introduction to Fault Tree Analysis. In: 2012 Annual Reliability and Maintainability Symposium. USA. January 2012. 1–3
- CSERMELY, P. (2005): A rejtett hálózatok ereje. [The power of hidden networks] Vince Kiadó, Budapest. (in Hungarian)
- DOROGOVTSSEV, S.N. (2000): Structure of growing networks with preferential thinking, Phys. Rev. Lett. 85, 4633.
- NEWMAN, M.E.J. (2003): Random graphs as models of networks. In: Bornholdt, S. (ed.): Handbook of Graphs and Networks, Wiley-VCH GmbH & Co. KGaA, Weinheim. 35–68
- STAMATIS, D.H. (2003): Failure Mode and Effect Analysis, ASQ Quality Press, Milwaukee

