

**HUNGARIAN**

**AGRICULTURAL**

**ENGINEERING**

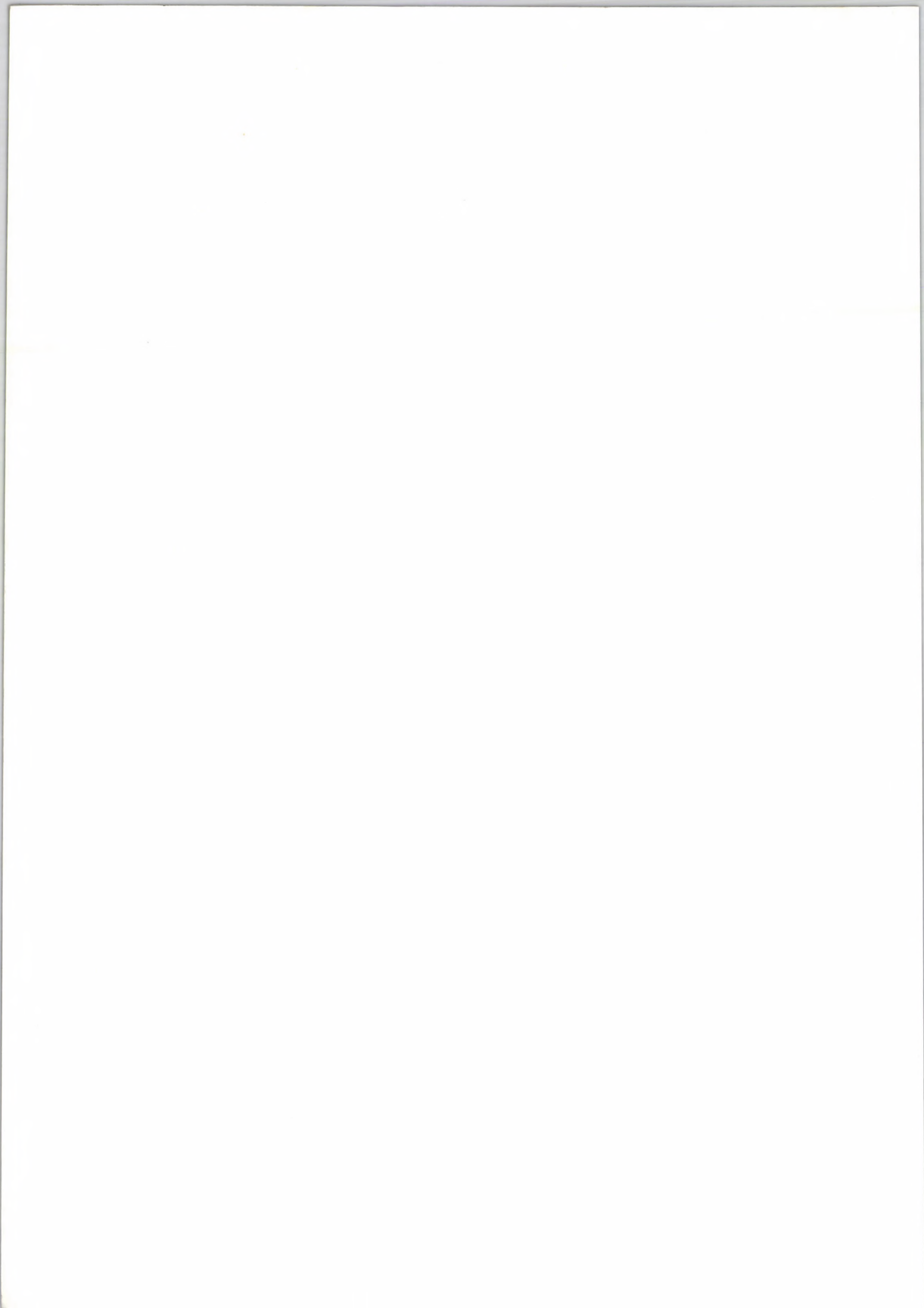



**HUNGARIAN AGRICULTURAL ENGINEERING**  
**N<sup>o</sup> 6/1993**

Editor:  
Prof. Dr.László Tóth

HU ISSN 0804-7410

– Gödöllő –

HUNGARIAN AGRICULTURAL ENGINEERING  
N° 1993

HU ISSN 0864-7410

- öllöb6F -

# PREFACE

The Agricultural Engineering Board of the Hungarian Academy of Sciences which supervises the development of this branch organises annually a conference at Gödöllő, which is the central place of the Hungarian agricultural scientific activity.

During the sessions, research scientist, developing engineers, experts of institutions engaged in agricultural engineering development strong in numbers the organizer, the hungarian universities and other higher grades of education, the research institutions: Hungarian Institute of Agricultural Engineering at Gödöllő, Faculty of Agricultural Engineering of the University of Agriculture at Gödöllő and foreign guests give account of their results obtained in the research work and development of agricultural machinery.

This yearly English-Language publication the "Hungarian Agricultural Engineering", started at 1988, contains selected papers presented at the conference of 1993. To the published scientific papers are enclosed reports of the test performed by the Hungarian Institute of Agricultural Engineering at 1991. We do hope that this publication will be found interesting to a big part of agricultural engineers.



György Mészáros  
director

Hungarian Institute of Agricultural Engineering  
Gödöllő

125 years anniversary  
Hungarian Institute of Agricultural  
Engineering





## PART I.

# ABSTRACT OF SELECTED PAPERS

POSSIBILITIES OF FIGHTING POLLUTION  
ENERGY RESPONSIBILITY IN THE INDUSTRIAL  
ECONOMY

Dr. K. H. JOHNSON  
University of California, Berkeley

The author discusses the possibilities of fighting pollution in the industrial economy. He points out that the industrial economy is the major source of pollution and that it is essential to find ways to reduce pollution from this source. He discusses the role of government, industry, and the public in this effort. He also discusses the importance of energy conservation and the development of new energy sources. The author concludes that a combination of these measures is necessary to reduce pollution from the industrial economy.

METHOD FOR CLEANING THE FILTER  
MATERIAL IN ENVIRONMENTAL FILTERS

The author describes a method for cleaning the filter material in environmental filters. The method involves the use of a special cleaning solution and a special cleaning process. The author explains that this method is more effective than other methods and that it can be used to clean a wide variety of filter materials. The author also discusses the importance of regular cleaning of environmental filters and the benefits of using this method.

ELABORATION OF A BIODEGRADABLE  
PROCEDURE FOR FIBER CLEANING

Dr. M. KELLER - Dr. J. KELLY - Dr. J. KELLY  
University of Southern California, Los Angeles

The aim of our research is to develop a biodegradable procedure for fiber cleaning. This procedure involves the use of a special cleaning solution and a special cleaning process. The author explains that this procedure is more effective than other procedures and that it can be used to clean a wide variety of fiber materials. The author also discusses the importance of regular cleaning of fiber materials and the benefits of using this procedure.

AUTOMATICATION OF FILTERING OF  
CLEANING PROCESS

Dr. J. KELLY - Dr. J. KELLY  
University of Southern California, Los Angeles

The author discusses the automation of the filtering of the cleaning process. He points out that the automation of this process can lead to significant improvements in efficiency and cost. He discusses the challenges of automating this process and the solutions that have been developed. The author concludes that the automation of the filtering of the cleaning process is a promising area of research.

## **POSSIBILITIES OF PRODUCING RENEWABLE ENERGY RESOURCES IN THE AGRICULTURAL ECONOMY**

Dr. K. KOCSIS  
University of Agricultural Sciences, Gödöllő

To summarize foregoings the biomass origin energy source materials in the European FAO member countries can be estimated about 140 million tOE per year that is approximately four times of the fossil energy need of the agricultural industry branches and that is 10 percent of the total energy consumption of the region. With maximum utilization of the potential reserves the biomass origin energy sources could substitute about 44 % of the presently consumed liquid energy sources and 15 % of the total engine fuel consumption.

Based on the mentioned facts one can state that in the far future the agricultural industries can be reformed to become energy self-supplying and net energy producing branches by changing considerably the production targets, profiles and technologies. Producing and using of environment friendly and clean so called green energy sources can contribute in a significant extent to establishing a sustainable agricultural production and rural development and to solving environment pollution problems of micro and macro regions by means of closed CO<sub>2</sub> cycle biomass origin fuel and heating materials.

## **METHOD FOR PLANNING THE UTILIZATION OF MANURE IN ENVIRONMENTAL FRIENDLY MANNER**

GY. MÉSZÁROS - Dr. L. FENYVESI - L. MÁTYÁS -  
Dr. B. KULI - P. HORINKA  
Hungarian Institute of Agricultural Engineering, Gödöllő

In the scope of the development task such a nutrient supply method is worked out that beside saving of the soil the environmental saving utilization of manure can also be achieved. The programme consists of three parts: determination the composition of the soil, the field oriented manure distribution and modifying of the manure composition to be distributed.

The paper deals with the determination of the area distribution of the soil characteristics. By our elaborated method distribution of organic carbon content of the soil can be determined with not more than 5 % error. Among the macro elements distribution of those can be given from which deficiency can be observed. Obtained results can be documented by rasters so these can be processed by the help of such known photo informatic systems as the ARCIINFO.

## **ELABORATION OF AN ELECTROPHYSICAL PROCEDURE FOR SEED CLEANING**

Dr. P. SZENDRŐ - Dr. J. KOLTAY - Dr. GY. VINCZE  
University of Agricultural Sciences, Gödöllő

The aim of our research is working out, establishing a procedure theoretically and practically for separating bulks of components behaving different way in changing polarity, zero mean value, high voltage impulse generated electric field.

In the course of our research the aim was to establish an electrophysical procedure theoretically which can be used to a sorting technology in order to separate mixed seed (grain bulk) components more effectively in comparison to those being used

so far. The basis of the technique lays on the characteristics having not been utilized.

## **SOIL PHYSICAL AND TILLAGE ENERGETIC INTERACTIONS**

Dr. B. SINÓROS-SZABÓ - Dr. B. KAZÓ  
University of Agricultural Sciences,  
Agricultural Engineering College, Nyíregyháza

In the arable land plant production two main questions are highlighted: increasing yield and making the work more rational. The additional novel topic is the environment. In the environment of arable land economy (above all at the soil) such an extent damages has taken place what queries fundamentals of our existence included in the cropland.

The arable land economy need to be rethought and only this can lead to results insuring long term perspective. Complex solutions are inevitable such as interaction examination of the system of physics and mechanics of soil and tillage part, the better and more exact knowledge of soil-material system as well as the changes of them through the cultivation energetic changing. Practical application of multivariable soil-machine interaction in consultant level includes the soil protection, moisture keeping, precipitation utilization and especially the favourable values of tillage cost.

## **PIG HUSBANDRY ON DEEP LITTER**

L. MÁTYÁS - Dr. B. KULI  
Hungarian Institute of Agricultural Engineering, Gödöllő  
Dr. G. MÁRAY - E. GYÖKÖS PÁLVÖLGYINÉ  
University of Agricultural Sciences, Gödöllő

In order to test the deep litter housing technology in Hungarian conditions 15-15 pigs were fattened in two 16 square meter boxes on 80 cm thick sawdust litter. In the interest of manure decomposition on the spot the litter was treated with SEF-C and ENVISTIM bioactive litter additive agents.

The litter was regularly rotated by man-power. Automatic feeders combined with nipple drinkers were used for feeding and drinking. As control 8-8 animals were fattened in 8 square meter boxes in traditional liquid manure system.

In the course of the July-August first fattening cycle due to several unfavourable effects the results of both the experimental stock and the control one were worse than expected. In the September-December production cycle the daily weight gain was 652 and 641 g on the average of the experimental groups, while that of the two control group was 621 g.

Thus the weight gain by the deep litter groups was higher by 5 and 3.3 %. The feed conversion efficiencies were 3.52, 3.59 kg/kg and 3.67 kg/kg respectively.

As a result of the deep litter technology compost type material was formed instead of great amount of slurry.

## **AUTOMATIZATION OF MILKING DEVICE CLEANING PROCESS**

Dr. L. TÓTH - Dr. J. BAK - J. BOLYÓS  
Hungarian Institute of Agricultural Engineering, Gödöllő

The Hungarian Institute of Agricultural Engineering have been dealing with the robotization and automatization of milking equipments since 1988. Connected this work experiments were carried out for automatizing milking machine

cleaning and periodical rinse. It was a fundamental aim that they could be integrated to both traditional milking devices and milking robots. There were further requirements of saving energy and chemicals in the cleaning process, as well of good quality, low seed number milk produce.

## COMPARATIVE TEST WITH DIFFERENT BIO-DIESEL FUELS IN TRACTOR ENGINE

Dr. I. J. JÓRI - Dr. M. SZENTE - G. RADVÁNYI  
Hungarian Institute of Agricultural Engineering, Gödöllő

As a part of "Alternative fuels for engine" R and D work which was support by OMF and four Ministry (KHVM, KTM, FM, IKM) we have done a comparative test with diesel fuel, RME (from Austria), RME (Győr) and rape oil mixture (Schur) in tractor engines (MTZ-80 and Zetor 160.45).

Based on the results of the bench engine test with different kind of fuels, Diesel fuel, RME - from Austria and Hungary and rape oil mixture (Schur), we can conclude that:

- The operation of the agricultural tractors (engines) has no any limitation with rape oil fuels,
- Using different rape oil fuels the engine power decreases by a few % compared to Diesel fuel. Otherwise the energy consumption and the efficiency of the combustion becomes a bit better,
- At the test condition was no any significant differences between the results getting from RME's and rape oil mixture (Schur).

## DRUM CAGE SUPPORT FORCES AND THE DRIVING FORCE OF DRUM

Dr. P. SOÓS - Dr. ZS. SZÜLE - Dr. J. KOLTAY -  
Dr. K. PETRÓCZKY  
University of Agricultural Sciences, Gödöllő

The power need of threshing drum was investigated in several countries in the past decades. The concave support forces were however measured hardly. This is now timely because the electronics developed a lot so that the possibility of material transmission monitoring is available. Despite there are already such kind of automates but their control signal measuring place is far from the drum which can be a source of uncertainty.

The drum concave force can be a certain basic signal of the automatic monitoring of transmission. We wish to carry out the measurement on the field in arable land conditions. The declination and torsion of drum shaft will be measured together with the necessary acceleration moment and power. As an introduction to our gap filling measurements in order to get informed the most important professional literature has been collected and are evaluated. Some of them will be shown here.

## APPLICATION OF THERMOGRAPHY IN AGRICULTURAL ENGINEERING RESEARCH

Z. PAPP  
Hungarian Institute of Agricultural Engineering, Gödöllő

Determination of surface temperature making use of remote sensing and thermovision serve new ways of approach to solve problems of several fields of agricultural research. Surpassing the possibility to examine thermal processes without disturbing the environment the method with the available technical

background including video and RGB system and computer processing units ensures such an evaluation possibility to the user which can not be solved with any other technique. The paper shows the possibilities of application through some practical examples.

## EXAMINATION OF GRAIN MILL FOR SMALL SCALE FARM

Dr. GY. GYÓRFY  
University of Agricultural Sciences,  
Agricultural Engineering College, Mezőtúr

Investigations were carried out with FV-III-S type crushing mill. Wheat and corn produces were used. The investigation was made with different screen sizes and at a single output rate repeated three times.

According to our measurements with Ø3 screen 1.6 mm groats average particle size, 17.72 Wh/kg specific energy intensity as well as 1.5 groats average particle size and 8.52 Wh/kg specific energy intensity were showed up for wheat and maize, respectively.

With the tested machine the ratio of fractions above 1.6 mm were above 40 % in every case and their values reached 50-70 % when using larger size screens. The specific energy need of the machine can be characterized by regression relationships of  $E_{fb}=43.56 M^{-1} - 8.72$  (Wh/kg) ( $R=0.983$  correlation quotient,  $S=0.843$  standard deviation),  $E_{fk}=21.69 M^{-1} - 6.53$  (Wh/kg) ( $R=0.969$  correlation quotient,  $S=0.455$  standard deviation) for wheat and maize, respectively. In the expressions M is the groats average particle size (module).

In short it can be stated that the mill is applicable to produce larger size of groats as desirable besides high specific energy consumption.

## THERMOVISION METHOD FOR THE MEASURING OF THE KERNEL'S SURFACE TEMPERATURE DURING DRYING

M. NEMÉNYI - K. KACZ - I. CZABA - A. KOVÁCS  
PANNON Agricultural University, Mosonmagyaróvár

Research programmes aiming at the drying process of maize hybrids already began at the Pannon Agric. Univ., Faculty of Agricultural Sciences in 1981. Within the project from 1981 to 1984 physical (first of all heat physical), chemical and morphological tests of the hybrid grains of different drying characteristics were carried out. Knowing the drying functions and the surface area of kernels (a new calculation method has been elaborated for this by Neményi and Szodfridt 1985) the diffusion coefficient of the tested hybrids was calculated as a function of temperature and moisture content. On the basis of it, diffusion functions and the mathematical connections among diffusion parameters and the distinctive features of the substance were set up (Neményi 1983, 1988 and 1990; Neményi and Szodfridt 1985; Neményi and Szabó 1987).

In the next step (1985-1986) the so called endosperm mutants, firstly the Opaque 2 hybrids were tested. Ripening of the endosperm mutants is slower than that of the normal hybrids; but at the same time under artificial circumstances the Opaques dry more intensively. We tested that how much Opaque 2 gen ingestion speeds up the drying under artificial circumstances, in that way that ripening still does not slow down (Neményi 1988).

From 1986 different hybrids (56) were tested resp. ranked in the interest of the practical application of the research results.

## **ENGINEERING AND ENVIRONMENT PROTECTION QUESTIONS OF VEGETABLE ENGINE FUELS**

Dr. A. VAS - Dr. V. VARGA  
University of Agricultural Sciences, Gödöllő

In several countries of Europe including Hungary attention is focused on the questions of vegetable oils fuel application in diesel engines.

The properties of plant oils - treated in different ways, mainly esterified - have approximately the same properties as fossil diesel oils have. In our study engine tuning, operational specialities and environmental load are dealt with and compared.

## **MATHEMATICAL MODEL OF MASS REDUCING OF TILLAGE MACHINES**

Dr. I. PÁLINKÁS  
University of Agricultural Sciences, Gödöllő

The author describes theoretical considerations supported by soil box measurements with plough, harrow and disk. The useful mass calculation expression has been elaborated for each examined cultivation ways. The influence of machine mass reducing on such important parameters of implement - power machine - soil system as hauling force, pressure on soil and energy consumption. Furtherly those formulas were also elaborated which can be used to estimate the extent of mass reducing of a machine part if the cross section or material or both of that is modified practicably.

## **OPERATION EXPERIENCES OF DAIRY COW PLANTS SUPPLIED WITH COMPUTER PRODUCTION MANAGEMENT SYSTEM**

Dr. A. ERÉNYI  
University of Agricultural Sciences,  
Agricultural Engineering College, Mezőtúr

In our dairy farms computerized plant management systems were installed partly as home development and partly adapted from different western European countries. In the research operationally important questions as accuracy of animal identification with different technical solution units, relations of the number of feeder and the number of animals, milk meter operation with milking devices are covered. The investigations seek for answers to the economy of creation of systems taking into account the operation aspects.

## **ANALYSIS MEASURING ERRORS OF MEASURING CIRCUIT BUILT WITH THERMOCOUPLE**

Dr. GY. VINCZE - I. SERES  
University of Agricultural Sciences, Gödöllő

Temperature sensors built with thermocouple are widely used in practice. In the course of our research work a measuring arrangement and evaluation method without fixed reference point was elaborated. In our paper systematic errors of the assembly are analyzed by means of non-equilibrium thermodynamic. The dependence on electrochemical potential temperature gradient and static magnetic fields is touched.

Based on literature data the concrete calculations are carried out for copper-constantan thermocouple, as well.

## **ROUTE PLANNING ON TRANSPORT NETWORK**

Dr. J. BENKŐ  
University of Agricultural Sciences, Gödöllő

Today no one argues that transport is most costly and important operation of logistic activities. Traffic manager who manipulates vehicles faces to simple everyday problems of route planning, vehicle distribution, path and connection determination etc. Amongst them route determination is the most frequent problem, which means nothing else but the seeking for optimal path of a vehicle on a given traffic network.

## **A SYNTHESIS OF THE INTER-RELATIONS ANIMAL HOUSE, ENVIRONMENT, RENTABILITY, HUMAN AND ANIMAL WELFARE**

Dr. A. MATON  
RvL, Merelbeke, Belgium

The environmental elements of husbandry processes are important factors, nevertheless they are not exclusive standpoints of the economical production. The effective factors should be considered in the wider system of relations. In the case of cow, pig, and poultry plants one can evaluate the advantages and disadvantages of housing with or without litter only taking into account all the factors such as investment cost, labour need, emissions, comfort feeling, etc.

It can be stated, that in the case of housing a compromise should be found. Such an equilibrium should be formed where the roles of single factors can not be overlapped.

## **HEAT- AND MATERIAL TRANSPORT PROCESS IN DRYING OF SEED PEAS**

Dr. J. CSERMELY - Dr. Z. BELLUS - Dr. M. HERDOVICS -  
GY. KOMKA  
Hungarian Institute of Agricultural Engineering, Gödöllő

Drying process of seed peas in tower with vertical vent pipe was examined in different heights along the radius of the tower.

16.3-17.7 tons units of peas with 16.3-17.0 % starting moisture were ventilated with pre-heated air which has a temperature of 37.3-40.8 °C and a relative humidity of 26.2-28.2 %.

Drying in radial direction at the 2/3 height of the tower lasted for about 15 hours, while near the casing, except the upper measuring points, for about 22 hours. Drying process can be characterized by exponential equations of an  $r = 0.93-0.99$  regression coefficient.

## **NON-DESTRUCTIVE METHOD OF FRUIT ELASTICITY DETERMINATION**

Dr. A. FEKETE  
University of Horticulture and Food Industry, Budapest

A simple and rapid non-destructive method was developed to determine the elasticity characteristic of fruits. The latter was defined by the coefficient of elasticity of the fruit that is dependent on the compressive stress and on the deformation.

A penetrometer was developed to perform experiments. Compressive stress and strain characteristics were measured with different varieties of fruits to determine the coefficient of elasticity and to compare it with conventional parameters of fruit strength.

### **WARMING UP OF BARLEY GRITS IN HAMMERMILL (OTKA)**

Dr. I. BÖLÖNI - Dr. J. CSERMELY - S. SALAMON  
Hungarian Institute of Agricultural Engineering, Gödöllő

The warming up has very important role in the comminution process and at the determination of the hammermill's technical efficiency (%). Regression analysis carried out on barley grits (water content = 13,5 % w.b.) proved, that the  $\Delta t$  warming up of grinds is influenced by the fineness of the grits (particle mean size or specific surface area) just in 18-19 %, while by the specific grinding energy requirement (kWh/t) only by 5 %.

It is surprising, that the warming up of the grits varies at about the same level, when screen is not applied at all.

### **APPLICATION POSSIBILITIES OF SOLAR AND WIND ENERGIES IN THE ENTERPRENEURIAL ANIMAL FARMING**

Dr. L. TÓTH - Dr. J. BAK - P. PECZNIK  
Hungarian Institute of Agricultural Engineering, Gödöllő

The object of our work was to develop and test the water and electricity supplies generated and served by wind machines and solar cells of a sheep farm having 100-150 ewes. The daily water demand of the farm is 1500-2000 litre. Because of the expected 3-5 days of calmness period we planned the water tank of 10 m<sup>3</sup> capacity. SZV-2 multi blade wind-machine with diaphragm pump is used for lifting the drinking water from a dug well having the water level in 2-5 m deep. We built in altogether 8 compact fluorescent tubing of 9 and 11 W power capacity to light the sheep fold, about 45 m<sup>3</sup> and a part of social building consisting of 3 rooms. The electricity supply and storage were given by four SIEMENS made M40 type solar cells, LR-4 charging regulator and two 100 Ah batteries. The efficiency of 12 V D.C. system is about 12 % and the planned least average daily energy utilization is 12 hours. Parallel with the lighting system of sheep farm for small farms we have developed a very simple solar-water collector, which is combined with a hot water boiler of 200 storage capacity. The boiler beside the solar energy can be heated by agricultural wastes and residues.

### **INTENSIVE MIXING THE CEREAL BULKS BY PNEUMATIC METHOD DURING STORAGE**

Dr. K. KACZ - Z. SÁRKÁNY  
PANNON Agricultural University, Mosonmagyaróvár

The main point of the patented method is to place elastic, inflatable hoses into the store and by the inflation and deflation

of these hoses grain layers can be moved. With this method, on one hand, the forming of rotting part can be prevented, existing centres can be eliminated; on the other hand, the method combined with ventilation can increase the safety on the storing.

The other advantage of the method is that it does not cause mechanical damages to expensive seeds.

With these experiments our aim was to increase the intensity of the mixing wet and dry parts of the stored grain.

### **QUALITY CONTROL OF BIOBRIQUETTES AND EXPERIENCES WITH THEIR COMBUSTION**

P. PECZNIK - GY. VARGA  
Hungarian Institute of Agricultural Engineering, Gödöllő

Good solid fuel can be made of the different combustible agricultural residues and of by-products. While testing these fuels we did not recognize exact relation between the stability and burning characteristics. The good solidity is important because of storing and delivery, and can be achieved by different pressing methods.

Given the same stability, the quality is first of all determined by the burning characteristics. The well-known agricultural and wood industrial residues and by-products can be considered as environmentally clean fuels.

The testing methods and the system we have worked out are suitable for the objective qualification of biobriquettes. With its help we can avoid getting briquettes made of environmentally dangerous materials and having bad burning quality on the market. It is in the interest both of the users and the producers and the distributors.

### **APPLICATION POSSIBILITIES OF FINITE AND BOUNDARY ELEMENT METHODS IN CLIMATE CONTROL DESIGN OF GREENHOUSES**

Dr. F. KASZA  
University of Agricultural Sciences, Gödöllő

Finite Element Method (FEM) is applicable to solve heat conduction, heat flow, heat radiation and diffusion type problems. In the case of glasshouses the inner desired and uniform climate are determined by the physical phenomena of heat flow and conduction as well as vapour diffusion. They are the most important to be followed by climate control. The greenhouse climate are also influenced by outside condition such as outdoor temperature, solar radiation and air vapour content.

Two most important characteristics of the glasshouse climate are temperature and vapour content. The change of them can be described field differential equations, which can be effectively solved by FEM or Boundary Element Method (BEM). To solve the coupled or simultaneous differential equation one should know the boundary and initial conditions. They are given by outer heat transfer, heat radiation, moisture content, evaporation, ventilation, shading, etc.

The final aim of this long term research to respond the technical solution issues of the necessary heating, cooling, evaporating and ventilating in glasshouses.

...the ... of ...  
...the ... of ...  
...the ... of ...

...the ... of ...  
...the ... of ...  
...the ... of ...

### QUALITY CONTROL IN RESEARCH

...the ... of ...

...the ... of ...

...the ... of ...

...the ... of ...  
...the ... of ...  
...the ... of ...

...the ... of ...  
...the ... of ...  
...the ... of ...

...the ... of ...

...the ... of ...

...the ... of ...

...the ... of ...

...the ... of ...

...the ... of ...

...the ... of ...

...the ... of ...

...the ... of ...

...the ... of ...

...the ... of ...

...the ... of ...

...the ... of ...

...the ... of ...

...the ... of ...

...the ... of ...

...the ... of ...

...the ... of ...

...the ... of ...

...the ... of ...

...the ... of ...

...the ... of ...

...the ... of ...

...the ... of ...

...the ... of ...

...the ... of ...

...the ... of ...

...the ... of ...

...the ... of ...

...the ... of ...

...the ... of ...

...the ... of ...

By V. K. Kozlov, Institute of Agricultural Sciences, Moscow, U.S.S.R.

The article discusses the possibilities of producing renewable energy resources in the agricultural sector. It examines the potential of various energy sources such as solar, wind, and biomass, and evaluates their economic and environmental benefits. The author also discusses the challenges and opportunities associated with the development of these energy sources in agriculture.

## PART II.

# SELECTED SCIENTIFIC PAPERS

This section contains several scientific papers related to renewable energy resources in agriculture. The papers discuss the technical aspects of energy production, the economic viability of different energy sources, and the environmental impact of agricultural energy systems. The authors provide detailed data and analysis to support their conclusions.

The agricultural sector has a significant potential for producing renewable energy resources. This potential can be realized through the development of various energy technologies and the implementation of appropriate policies. The authors emphasize the need for further research and investment in this area to ensure a sustainable and energy-efficient agricultural sector.

The authors discuss the various challenges and opportunities associated with the development of renewable energy resources in agriculture. They highlight the need for a comprehensive approach that takes into account the economic, environmental, and social aspects of energy production. The authors also discuss the role of government and other stakeholders in promoting the development of these energy sources.

The authors provide a detailed analysis of the potential of various energy sources in agriculture. They compare the economic and environmental benefits of different energy sources and discuss the challenges associated with their development. The authors also discuss the need for further research and investment in this area to ensure a sustainable and energy-efficient agricultural sector.

The authors conclude that the agricultural sector has a significant potential for producing renewable energy resources. This potential can be realized through the development of various energy technologies and the implementation of appropriate policies. The authors emphasize the need for further research and investment in this area to ensure a sustainable and energy-efficient agricultural sector.

## POSSIBILITIES OF PRODUCING RENEWABLE ENERGY RESOURCES IN THE AGRICULTURAL ECONOMY

Dr. K. KOCSIS  
University of Agricultural Sciences, Gödöllő

On the basis of the available statistical data and estimations which are uncertain in several aspects the direct (technical) energy source consumption was approximately 37 million tOE in the 29 FAO member countries at the end of the eighties (while the relevant figure in Hungary is 1.6 million tOE). That is around 2.6 % (5.7 % in Hungary) of the commercial energy consumption of those countries. Included in this total agricultural purpose energy consumption the liquid energy resources (24.4 million tOE) and the electric energy (5.4 million tOE) take the highest part the solid and fluid energy source demand is moderate. As for the main application purpose the fuels share 15.0 million tOE (0.7 million tOE in Hungary), the heat energy need share 16.8 million tOE, while the electric energy consumption share 63.0 billion kWh (in this country 0.7 million tOE and 1.8 billion kWh, respectively).

At present within the approximately 1.7 million tOE (0.12 million tOE in Hungary) renewable energy consumption of the European agricultural branches the direct heating of traditional wood and forest and wood industry by-products (1.2 million tOE) and straw (0.3 million tOE) is the most significant which is completed with consuming 0.1 million tOE geothermic energy. The significance of other renewable energy resources is negligible although in Mediterranean countries the water heating with solar energy and the local electric energy supply based on wind energy is widely used in seaside areas.

According to the experiences of researchers and engineers working for the more than 400 institutes of 24 European countries taking part in the FAO European Agro-Energetic Research Cooperation Network the utilization of agricultural and forest economy origin biomass can be considered the most significant potential renewable energy resources. In the above mentioned FAO countries energetic aim utilization of 140 million tOE (3-4 million tOE or so in Hungary) biomass can be considered as a realistic future target.

Within this environment friendly biomass origin energy resources approximately 100 million tOE can be utilized for direct heat supply and in smaller extent for coupled heat and electric energy supply in Europe, while depending on the extent of this purpose areas 10 to 40 million tOE (1 to 2 million tOE in Hungary) biomass origin liquid fuel can be produced without any harmful effect to the food production and the agricultural economical conditions.

As it can be seen in the above comparative data the more widely understood agricultural production branches (agriculture, forest economy, primary food and wood process, agricultural industries, etc.) renewable energy resource producing ability is about four times of their commercial (fossil) energy need i.e. the agricultural production can become a net energy producing branch in future prospect.

### *The agricultural production as environment friendly energy producing industry*

In Europe the total heat energy need of food production can be satisfied utilizing merely 15-20 % of the potential amount of biomass and using further 20-25 % of the potential asset would supply the entire heat energy need of the rural population. As a result of the extremely intensive European research and development the moderne and effective small and moderate capacity biomass burning technologies are available apparently. Those technologies are widely used in the northern European and some central European countries and spreading

the technologies in other countries including Hungary depends dominantly on the political and agricultural political measures.

After the initial prosperity of energy aim utilization of biomass and the relevant R&D activity due to the energy price explosion and after the subsequent decline in the past years there is an increasing interest. The reason can lay on the extension of the energy self-supplying system of the agricultural production having a hard time as well as on the increasing utilization of agriculture as an energy producing industry branch.

The expansion of energy effectivity and the hardly growing energy needs owing to the stagnant trends of world economy as well as the low level and stable international energy prices diverted the attention of the world from the some decade limits of the fossil energy stocks what will be undoubtedly extended by the fruitful research and exploring. At the same time the reducing and solving the world environmental pollution problems above all highlight the application of renewable energy resource utilization in the widest practice within which the biomass can play the most important role.

The most significant driving force of the development programmes is the environment saving energy producing and consuming effect originating from the closed CO<sub>2</sub> cycle achievable through energetic utilization of biomass. But other factors also play significant roll such as enlarging the ratio of forest and green areas in the interest of saving biosphere, saving soil, plant and animal world and the rational land utilization, employment of rural population in the European agriculture which struggles against growing overproduction.

In spite of the promising R&D results experienced in ECM countries and its large potential stocks of biomass origin energy sources the role of those is rather moderate in the energy composition and the practical utilization. The primary reason can be found in the lack of complex development targets and composing and consequent fulfilling undoubtedly necessary strategic R&D programmes. As a result of elaborating and realizing development programmes more coordinated than those until now and rational utilization of the country agricultural ecology potential and the yearly reproduced biomass stocks not only the energy self-supply of the home food production can be satisfied but there is a real chance to the agriculture to become a net energy producing branch, supplying such environment friendly energy resources to the other parts of agriculture what have a production serving the unfavourable producing field area utilization and the long term solution of the increasingly serious employment problems of rural population.

### *Energy producing potential of agricultural branches in Europe*

Consequently from the peculiarities of agricultural production and taking into account the energy consuming structure of agricultural production, despite that the large geographical extension agricultural production has extremely high stocks of potential renewable energy resources, in the European FAO countries only 3 MtOE solar energy and not more than 5 MtOE geothermic energy can be utilized first of all as local heat sources and less than 1-1 MtOE wind energy and mini and micro hydraulic energy resources to satisfy local electric needs.

Over against those mentioned above, in the same European countries the biomass origin energy source stocks reproducible year by year can be estimated 100-140 million tOE. The technologies of utilizing biomass origin renewable energy resources to heat supply are available in a couple of European countries and in the case of several technology variations the economy criteria is also insurable. The biomass origin energy resources are much more favourable than other alternative energy resources in the aspect of energy transform, storage, and

transport. In the point of view of national energy supply, the high crude oil import ratio as well as the energy structure of agricultural production, most important advantage of the biomass origin energy resources can be the applicability to produce liquid fuel with simple technologies.

On the basis of reports of FAO member countries by the normal and indulgent exploiting traditional forest and wood areas in addition to the circa 20 million tOE firewood approximately 20 million tOE (some 0.7 MtOE in Hungary) byproduct pertaining to the forest can be utilized for direct burning in the form of wood cut. This traditional biomass potential can be expanded with planting energetic forests and with novel combined utilization of marginal territories serving even environment conservation, that gives further circa 20 million tOE (about 0.7 MtOE in Hungary) biomass energy source without ecologically harmful overload, and without the loss of forest planting and wood exploiting programmes.

This time the agriculture of Europe consumes some 1.2 million tOE forest and wood industry waste and byproduct for heat production but with the 17 million tOE commercial firewood and the public aim heat energetic utilization of additional 2.5 million tOE forest and wood industry waste the wood industry can be considered the most significant renewable energy resource producing industry.

Considering the direct burning utilization of agricultural byproducts the cereal straw is the most significant biomass origin energy resource having about 21.5 million tOE yield yearly which can be utilized for this purpose. Out of this presently some 0.3 million tOE is used energetically. The Maize stalk and other dry byproducts which can be utilized much more difficultly has a further energy potential of some 7.6 million tOE. Thus in Europe altogether about 30 million MtOE agricultural byproduct can be applied for energetic purposes without damage of soil structure and fertility. From environment protection viewpoint perhaps the liquid manure causes the greatest damage. From this and other high moisture content byproducts with anaerobe fermentation biogas production circa 20 million tOE renewable energy resource can be obtained.

The traditional and the much more promising so called energetic plants can produce an amount of biomass origin liquid fuel reproducible year by year which depends above all on the size of the territories available for the purpose. The specific fuel output can be increased to 2.0-3.0 tOE/ha in the case of bio-ethanol and 1.5-2.0 tOE/ha with plant oils depending on the production and process technologies, but according to certain research results some energetic plants, not usable for human consumption, in addition to huge (60-90 t/ha) solid material production they can produce even 3.5-3.9 tOE/ha bio-ethanol.

Providing average yields, some 10-50 million tOE per year biomass origin liquid fuel can be produced through the utilization of hardly sellable food overproduction territories of about 8-12 million ha for energetic purpose without endangering the region food supply.

#### ***Technology and economy conditions of energy utilization of biomass***

The key point of rational utilization of biomass origin energy sources is analysis of production technology blocks which are in sophisticated interrelationships and of connections between blocks and the optimum inside technologies and part technologies i.e.:

- rational utilization of land in respect of ecology and production,
- producing large biomass output with moderate energy input - effective energetic transformation of biomass basic materials,

- rational transport, bringing in and distribution of biomass energy materials,
- highest effectivity final utilization of biomass energy.

In order to establish economically and technologically the spread the biomass origin energy materials in the future it is necessary to analyze first of all the following parameters and their mutual interactions in more versions with details and great precision:

- bio-energy basic material caloric value, specific yield, energy density per area,
- bio-energy basic material production (harvest) cost, commercial price,
- biomass energy transformation effectivity net energy equivalent and output,
- bio-energy material production and transformation energy input and O/I factor of energy,
- bio-energy material transformation technology and energy path investment expense,
- bio-energy material production and transformation technological and overall effectivity,
- specific energy cost of biomass origin energy source, etc.

The net energy output of low moisture content biomass production is around 0.3-1.3 tOE/ha, while in the case of energy forests created for this purpose this value is 1.7-2.6 tOE/ha. The net energy output of the previously mentioned liquid bio fuels is 0.8-2.3 tOE/ha, while that of a biogas producing technology based on special green fodder production is 2.0-2.7 tOE/ha.

The second most important element of rational utilization of biomass origin energy materials is the relations of energy output and input. Heat producing effectivity factor of produced or gathered agricultural and forest products and byproducts was only 50-60 % earlier, but with the new automatized equipments it is more favourable (70-80 %) what still less than that of modern hydrocarbon burning appliances. Harvest, transport and process energy need of solid biomass energy sources is only 7-14 kgOE/t, which results in highly favourable energy output/input ratio (1331) compared to the heat equivalent (180-220 kgOE/t) of these energy materials.

Specific cost of heat producing by burning forest and agricultural byproducts depending on the biomass energy sources production (harvest) cost and purchase price is more favourable in several countries even now if compared to the light oil heating cost. However the specific investment cost of biomass burning equipments 2.5-3.0 times of that of hydrocarbon burning apparatuses. That is why the wide practical spread of biomass burning first of all undoubtedly depends on the necessary energy politics measures, a certain extent government dotation and introducing the suitable interest system in the most European countries.

The best complex energy transform technologies producing the most valuable energy types, the middle and large capacity biomass production and biomass gasifying technologies have not been matured enough to be used widely in practice. It is necessary significant technology development to increase energy transform effectivity, to improve energy output-input relations, to reduce specific investment cost.

In general biogas producing equipments operate technically perfectly, they can be usually operated economically. Problems arise, however, with fitting the concentrated summer heat sources mainly to winter (seasonal) demands of small capacity heat consuming appliances, with storing the periodically produced surplus biogas in large amount, with the special operation of complicated and uncommon technologies to farmers. Above all the high investment costs and the low energy output-input cause that biogas production and gasifying technologies has too long index of return, and due to the

4-5 times investment cost of traditional heat supply the bioenergy technologies can be considered a real development direction today only in the case of considerable subsidization in the interest of improving environmental factors.

Energetic effectivity of traditional production technology of the liquid bioenergy materials, primarily that of the plant oils is acceptable, but the final energy output-input factor of bioethanol production is hardly above the value 1.0-1.2 moreover in the case of unfavourable energy pathes it can be even a negative value. As an example the energy input of rape seed oil production is about 200-250 kgOE/t and that of the traditional bioethanol produces is some 285-300 kgOE/t. The final energy output-input ratio of rape oil production is 2.1-3.9 which value can be increased to 4.5-8.4 by means of utilization of byproducts energetically. The primary energy output-input factor of bioethanol production can be increased to 1.8-2.1 values by means of careful selection of technology pathes and taking into account the biology utilization of

byproducts the final energy outputinput factor can be as high as 2.3-2.5.

Producing plant oil basis bio-fuels can be economical in several western European countries beside the present moderate crude oil prices if the farmers get the usual agricultural production subsidy for energetic plant production or if the government renounce the taxes and other governmental income on commercial fuels in the interest of increase the ratio of environment friendly energy materials. At the same time the economicalness of bioethanol production based on traditional plants can be hardly insure in the most western European countries beside the present costs of basic material production, process and commercial fuel prices. However, if the further development of biological principles, basis and biotechnology techniques will result in more effective production technologies or the international oil prices reach the level experienced in the previous years, the biomass energy source production, process and commerce can become economical.

# METHOD FOR PLANNING THE UTILIZATION OF MANURE IN ENVIRONMENTAL FRIENDLY MANNER

GY. MÉSZÁROS - Dr. L. FENYVESI - L. MÁTYÁS -  
Dr. B. KULI - P. HORINKA  
Hungarian Institute of Agricultural Engineering, Gödöllő

## INTRODUCTION

In the latest decades increasing and keeping up the yield on high level of the crop production was attainable only by increasingly growing dosage of artificial fertilizers. Using up of stable manure was pushed into the background. Owing to it condition of the soil was run down and at the same time distribution of the manure, produced in large quantities, was getting more and more difficult.

Because of the high prices, intensive usage of artificial fertilizers is impossible in Hungary at present, while in some cases unsolved manure-slurry handling endangers the animal husbandry itself.

Manure, produced in animal husbandry, if it is possible has to apply completely in such a way that increases the productivity and does not cause environmental burden. Satisfying all these requirements will only be possible if we are aware of the essential quality characteristics e.g. humus, nitrogen, phosphorus and potassium content as well as the quantitative ones e.g. location, specific quantity, rate etc.

Planning of nutrient supply, beside these above mentioned characteristics, also have to know the claims of the plant to be grown. For example glucose producing plants have demand of potassium while protein producing ones need high rate of nitrogen. Simplifying the problem we can state that with full knowledge of the soil characteristics is expedient to choose the plant to be grown. Supplying the nutrient content of the soil is also have to be done according to the requirements. In the interest of using up organic nutrient and reducing the environmental burden, utilization of all the manure is expedient.

Composition of the manure to be distributed can be set according to the requirements in different ways. For example in the case of feeding: enzyme added fodder, bacterial product for bonding nitrogen and phosphorus or by the help of fermentation process for reducing the nitrogen content, in housing: deep litter system, in slurry treatment: adding of artificial fertilizers, applying of mineral absorbents, settling, screening etc.

In the framework of a joint R&D the Hungarian Institute of Agricultural Engineering and the Bábolna Rt (joint-stock company) have set the aim to elaborate a method that is suitable for determination the distribution of the nutritive supplying on soil surface. Another aim was to improve technologies and machines for aerial oriented distribution of nutritive materials.

Our joint R&D is supported by the National Committee for Technological Development (OMFB).

## METHOD AND MEASURES

Owing to the required promptness and spatial tasks the remote sensing-monitoring and measuring method was chosen. We have shown on model soil that the amount of different kind of humus can be determined by optical characteristics of the soil surface [1,2]. According to laboratory experiments with soil patterns from Bábolna, we have shown that the humus content was unambiguously, while the amount of iron and lime, beside certain conditions, was determinable by the help of optical characteristics [3]. Better approach was reached in the visible range. However, measuring in 800-1200 nm range is suggested because disturbing effect of the atmosphere is less considerable.

It is presumable that using up the results gained from the uncovered soil surface the humus supply of cultivated land is determinable. On the other hand, we have to take into consideration two of disturbing effect that are easy to eliminate in laboratory circumstances. These are the effects of the moisture content of the soil and the measure of the sod or the micro-unevenness, the roughness.

According to the diagram and on the basis of the results two ranges, suitable for measuring, can be selected. If it is possible measuring is expedient at air-dry soil state since in that case the error is below 5%. The second measuring range can be suggested at evaporating-like soil state since in this case the air-dry state is not guaranteed on the whole surface. According to our experience by increasing the distance of remote sensing, effect of the micro-unevenness decreases. In order to eliminate the effect of the micro-unevenness following the cultivation, photos have to take at 1000-1500 metres.

Measuring were carried out on two test fields. One of them was divided by 12 plots the other by 15 ones. Dimensions of each plots were 100 x 100 metres. Soil samples were taken on the points of the grid. Colour measurements of infrared photos have been done on the site of the soil samples.

On the basis of the measurements on uncovered soil surface, using the photo-transformation, distribution of organic carbon and by chance lime can be drawn.

Quantity of micro elements can be determined on the basis of the crop yield. For this purpose aerial photos have to make on the plant covered area. Distribution of yield can be determined in the green zone [4]. Those micro-elements can be determined that are not found in the soil, because these elements determine the average yield.

Consequently, knowing the distribution of the organic carbon and the yield, distribution of the missing macro elements can be determined by the help of photo transformation.

## RESULTS, CONCLUSIONS

Relations among the density measured in green zone, organic carbon and the density measured in blue zone are shown in Fig.1.

On the basis of the connection set up distribution of organic carbon and lime can be drawn.

On the examined field the least quantity of both the potassium and the phosphorus is more than the values are given in handbooks. According to our supposition crop yield is determined mainly by the nitrogen content. For determining the distribution of the yield we have taken normal colour photos. Distribution of yield can be determined according to the graph in Fig.2.

Remarkable that the quantity of crop is determined not only by nitrogen to be in deficiency, but the organic carbon too (Fig.3).

$$N = 0.039 - 0.0013 H + 7.361 \cdot 10^{-6} G \quad r = 0.966$$

where N: Nitrogen content [g/kg]  
H: Humus content [g/kg]  
G: Mass of corn-cob [g/m<sup>3</sup>]

By the help of the gained connection, distribution of the nitrogen can be drawn. In the soil of the other test field amount of all macro elements was more than the given maximum value.

In this case the crop yield is determined by the humus content. Amount of humus can be given by the help of the infrared photo as it was described.

Distribution of yield is the same as the distribution of the organic carbon. In this manner on the basis of the green mass to be harvested decreasing the macro elements of the plot can be calculated.

**References**

1. Stefanovics, P.; Micheli, E.; Fenyvesi, L., 1989, Infrared reflectance of artificially prepared organo-mineral complexes, International Agrophysics, p. 99-105.  
 2. Fenyvesi, L.; Papp, Z., 1991, Remote sensing for nutrient and field mapping, Int. Symp. on Locating System for Agr. Mech. Proc., Gödöllő

3. Papp, Z.; Fenyvesi, L., 1992, Estimation of some features of soil content by the optical characteristics of the surface, 1st Alps-Adria Workshop on Satellite Data Evaluation and GIS Technologies, Keszthely  
 4. Mészáros, Gy.; Fenyvesi, L.; Mátyás, L.; Kuli, B.; Horinka, P., 1993, Measuring method for evaluation of the nutrient supply of the soil, Conference on Agricultural Mechanization, Section 1, Gödöllő

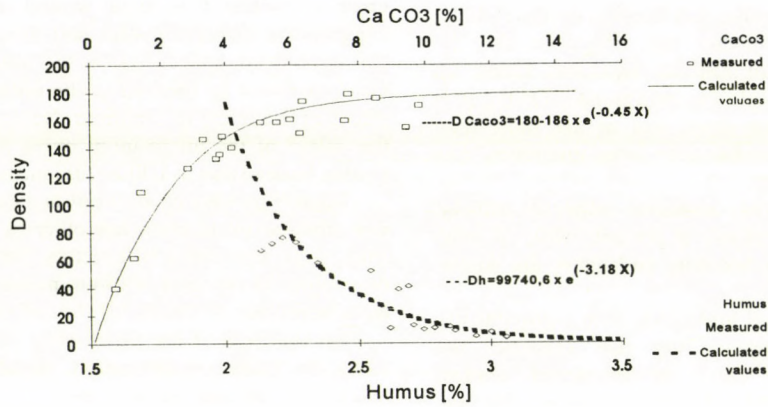

FIGURE 1.  
 Relations among colour characteristics, humus and lime content

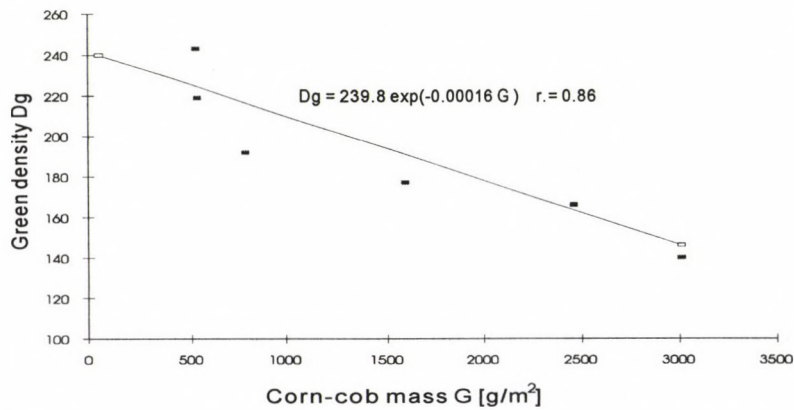

FIGURE 2.  
 Relation between corn-cob mass and density measured in green zone

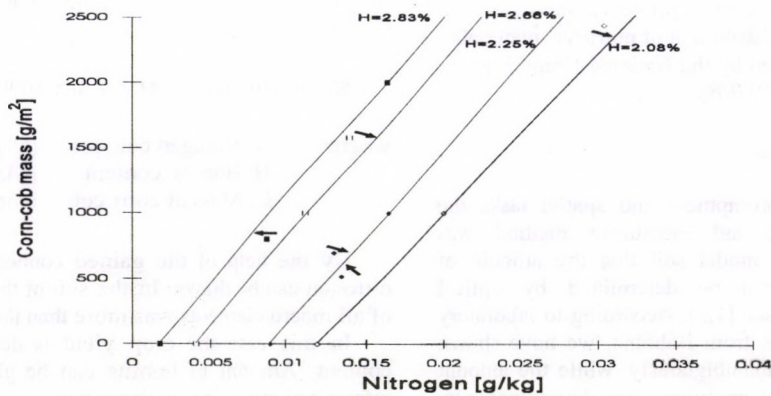

FIGURE 3.  
 Relations among corn-cob mass, humus and nitrogen content

# ELABORATION OF AN ELECTROPHYSICAL PROCEDURE FOR SEED CLEANING

Dr. P. SZENDRŐ - Dr. J. KOLTAY - Dr. GY. VINCZE  
University of Agricultural Sciences, Gödöllő

The aim of our research is working out, establishing a procedure theoretically and practically for separating bulks of components behaving different way in changing polarity, zero mean value, high voltage impulse generated electric field.

In the course of our research the aim was to establish an electrophysical procedure theoretically which can be used to a sorting technology in order to separate mixed seed (grain bulk) components more effectively in comparison to those being used so far. The basis of the technique lays on the characteristics having not been utilized.

In our work of years 1991 and 1992 a survey was made on the present state of the separation based on electrophysical properties. The polarization process was clear in agricultural materials. The corona charge and discharge phenomena was investigated. Then two experimental apparatuses were elaborated and built up based on the effect examined. The aim was to examine the basic effect producible by the experimental set-up and to change the theory necessarily. Finally the successful separation process was analyzed for the details of the effect.

The scheme of the electric set-ups is shown in Fig.1.

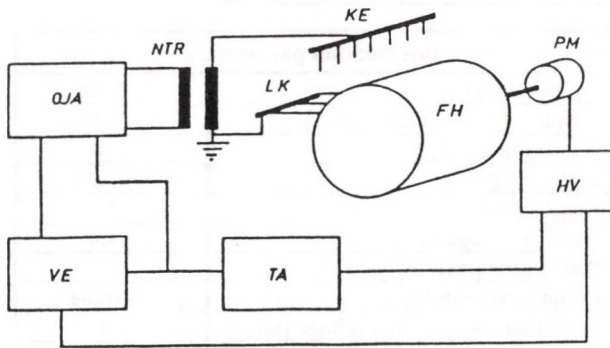

FIGURE 1.

A metal drum marked with FH is one of the electrodes. This is covered by isolating material and carries the material to be separated. The drum is rotated by the permanent magnet direct current motor marked with PM. The revolution of the motor can be controlled by the terminal voltage. This is supplied by the circuit HV which utilises the impulse width modulation (ISZV) principle. The corona charge is produced by the KE wire, edge, or needle row electrode. The electrode is fed through the high voltage transformer NTR with high voltage asymmetric impulses. The primer coil of the transformer is fed by oscillator and signal generating and forming circuit OJA.

The circuit is formed such a way that with high voltage transformer primer coil forms a forced control opening directional current regaining inverter. One can understand the operation on the basis of Fig.2. If according to the figure at the output of unstable multivibrator AM the voltage is positive then T transistor opens and the variable magnitude voltage supply gets the primer coil  $T_p$ . As an effect of the voltage the current in the coil increases linearly. At the change of the control signal to zero the transistor closes and the magnetic energy of the coil is fed back to the power supply unit through the auxiliary transformer  $T_2$ . The diode D determines the direction of the current.

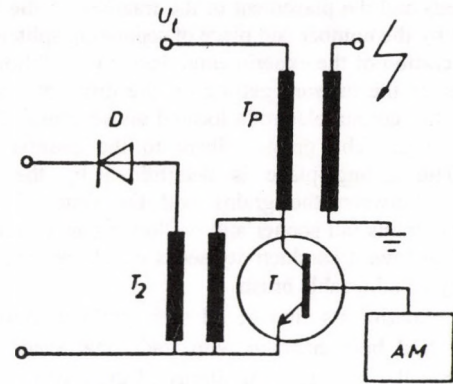

FIGURE 2.

The goal with the design was to reduce the energy demand of the power supply unit and to increase the effectivity.

In the course of experiments the circuit was adjusted to produce higher absolute value negative polarity peak voltage. The electric unit of separation apparatus has four control signal, such as:

- KE voltage magnitude
- KE frequency value
- KE supply impulse filling factor
- PM revolution value

The control signals characterized above is varied by the control circuit VE. The entire electricity need of the apparatus is supplied by the power supply unit TA.

The discharging brush LK shown in Fig.1 is an important part of the equipment. It removes the negative charges accumulated on the isolating surface of the drum. If it would not happen the charge stuck to the drum surface spoils the crown electrode KE field in the negative polarity part.

The mechanism of the experimental equipment consists of three parts such as grain feeder, technology unit, and divided collecting box.

The feeder is a vibrating system.

The main parts of the technology unit are: corona electrode, rotating grounded drum electrode and drum cleaner unit.

To collect the grains getting off the drum and to separate the fractions an eight section tray is used (Fig.3).

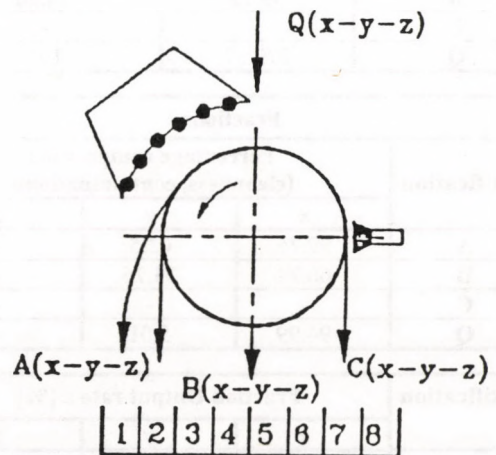

FIGURE 3.

After separation the number of the fractions of initial material (fed) and the placement of the fractions in the tray are determined by the number and place of separating splitters.

The operation of the experimental device is as follows. The components of the mixture getting on the drum electrode are charged by the corona electrode located above drum. This is a negative voltage. The grains adhere to the positive charge cylinder. The falling place is determined by the electric conductivity between the grains and the drum. The high conductivity grains fall sooner and the lower conductivity ones fall later. The lowest conductivity seeds which can not fall are swept off by an adjustable brush.

In our experiments first of all such grain mixtures were used, what had been handled with traditional seed cleaning machines, but the identity or similarity of the physical and the mechanical properties of the basic and the contaminating materials made impossible to be separated such an extent how that was needed by the quality of the final product. It can be mentioned as very important sorting tasks for example to separate poisoning weed seeds from the useful food grains and to filter out plant disease effects from sowing seeds, etc.

It was started in the course of the laboratory investigations that on the basis of the theoretical calculations and considerations the basic effect can be produced by the experimental equipment i.e. at a part of the mixtures the components can be separated to meet the practical needs.

Meeting the practical need is understood that the final material has a fraction cleanness (% distribution of components) meeting the standard specifications and the basic material producing factor is practically acceptable. The cleanness of the final produce is fundamentally influenced by the initial material cleanness i. e. if the material producing factor is the same than the cleanness of final produce can be different depending on the initial material cleanness.

As a consequence of the foregoing such mixtures are practical to be cleaned on the basis of the different electrophysical properties which have been adjusted to a degree of cleanness by using traditional grain cleaning machines. Due to the low output rate of the equipment the practical application can be taken into account primarily at the cleaning high value mixtures which can not be separated perfectly by traditional grain cleaners. Such kind of mixtures are - based on the mixtures having been examined so far - sclerotium infected helianthus, amarantus or datura infected millet seeds. They can be well sold abroad as bird fodder.

From our experiments it is concluded also that beside the cleaning of material a density based sorting is made depending on the type of basic material. This can be especially well utilized in the grass seed classification.

The practical applicability of the sorting in electric field generated by changing polarity, zero mean value, high voltage impulse series is shown through the results with handling amarantus. The results are included in Table 1.

**Table 1.**

**Working quality characteristics of sorting with amarantus cleaning**

Material characteristics	
Measurement identification	1992.11.27./2
Initial material	VR
- moisture content [%]	8.8
- place of origin	Vácrátót
Components	
- basic material: (x)	amarantus
- contamination: (y)	chaff, husk
(z)	
Identification of clean material:	A
Number of handling:	1

Fractions		
Identification	mass [g]	distribution [%]
A	239.85	85.80
B	39.72	14.20
C	-	-
Q	279.57	100

Identification	Fractions		
	Percentage composition (cleanness, contaminations)		
	x	y	z
A	99.75	0.25	-
B	66.24	33.76	-
C	-	-	-
Q	94.99	5.01	-

Identification	Fraction Output rate $\epsilon$ [%]		
	x	y	z
A	90.10	4.28	-
B	9.90	95.72	-
C	-	-	-

Intervention parameters	
Equipment type	drum
Peripheral or band speed [m/s]	0.766
Basic voltage [V]	14
Peak voltage [kV]	41.18
Negative voltage [kV]	2.8
Positive voltage [kV]	1.4
Period time [ms]	7
Corona electrode type	needle
Period time of positive voltage [ms]	1
Precleaning with traditional device yes or no	yes

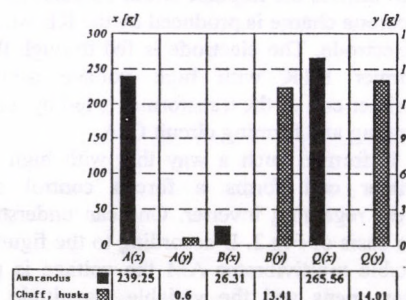
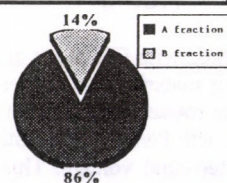

Cleaning affectivity $\eta$ [%]		
of y	of z	of y+z
95.00	-	-
Applicability		
excellent	-	-

Further statements to the experiments:

- The quality of separation and the practical applicability of the fractions are decisively determined by the differences between the electrophysical properties of the separated components. Thus for example chaff and husk can be separated from amarantus grain effectively and similarly sclerotium types from crocus, datura from millet but neither datura nor coriander could be separated from anise.
- Examinations expressed that the operation characteristics has a great effect on the separation quality.
- Different isolating materials were used to cover the grounded drum electrode (sorting surface). Artificial velour and thin PVC appeared the most practicable.
- In the course of examinations two electrode design were tried such as wire and needle row electrodes. According to our expectations the needle row electrode resulted in higher adhering forces than the wire type one.
- The double wounded teflon isolation proved inapplicable.
- Using a reflector electrode (at the potential) located above the electrode reduced significantly the corona charge diffusion due to the electric repulsion. Such a way the space charge concentration was increased and the corona charging time constant decreased.
- At the separation of mixtures investigated the peak value to the corona electrode was 6.5 to 47.0 kV, the frequency 125 to 500 Hz and the filling in factor 0.3 to 0.5. The average field intensity in the space between the electrodes was in the interval 10 to 19 V/cm.
- The sharpness of separation can be increased with changing the revolution of the drum. In the case of the materials examined the carrying drum rotated with 25-80 rpm.
- The electric power need (driving and electrode feeding) is in an interval 50 to 65 W.

## SOIL PHYSICAL AND TILLAGE ENERGETIC INTERACTIONS

Dr. B. SINÓROS-SZABÓ - Dr. B. KAZÓ  
University of Agricultural Sciences,  
Agricultural Engineering College, Nyíregyháza

### THE SOIL

The increase of production results, the mechanization of large scale agricultural economy, the usage of large dose artificial fertilizers, the production systems of the past years maltreated soil and soil environment. They changed the physical mechanical characteristics of the soil such an extent that made them a limiting factor. In the centrally managed economy system of the past 40 years the machine and soil interaction was not taken into account and more than necessary energy was used for tillage, since the arable land machine groups and soil cultivation assemblies were not adjusted operationally to the local state of soil cultivation.

### THE SOIL IS A NATIONAL TREASURE

The soil is a national treasure, and to prevent from further damage it need to be protected. Arable land economy with its principles and interactions should be newly rethink in a soil protecting, environment conservation conception as only this can lead to the results ensuring long term results. Complex problem solutions will be inevitable in the tillage and soil research and consultation protecting the soil mechanical, physical system, and in the energy saving soil cultivation assemblies, serving the environment and land conservation. In a scientific approach the interaction of soil and cultivation implements can be summarized in a so called interaction model (Fig.1).

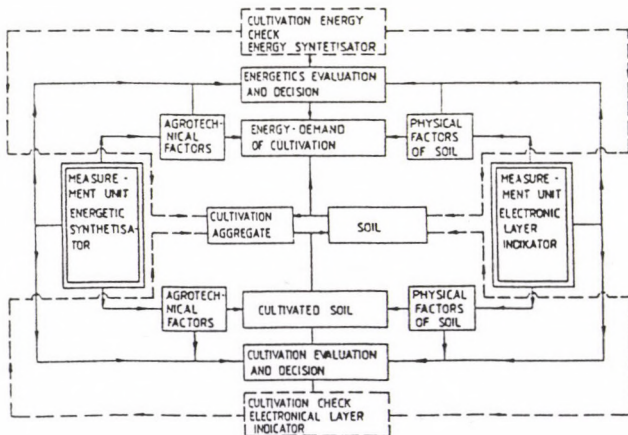

FIGURE 1.  
*System model of cultivation energetics*

### METHOD - "INTERACTION MODEL"

The interaction model shown comprehends cultivation, tillage energetic and land protection tasks to the production table level, the production ecology zones, the natural geographic regions. Based on measured data and the characteristic trends of single and serial measurements the set up and adjustment data of soil cultivation assembly types which give the highest quality and energy saving work.

Considering that the interaction has two determining factors i.e. moisture content and compactness of soil it is necessary to

examine both factors individually and together, as well. The individual relationship systems of factors playing role in the interdisciplinary main model (Fig.1) are given in submodels. Such kind of submodels are the soil moisture and compactness change shown in Fig.2 as well as the cultivation energy need (Fig.3).

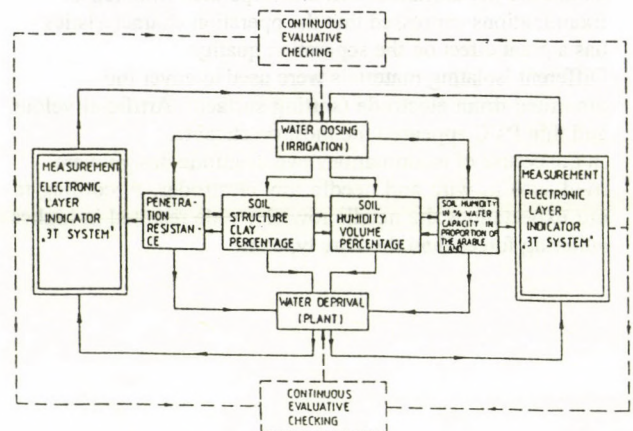

FIGURE 2.  
*System model of cultivation energetics soil  
Humidity and compactness model*

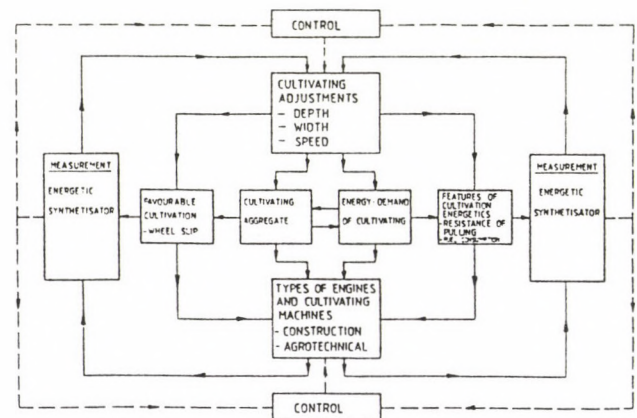
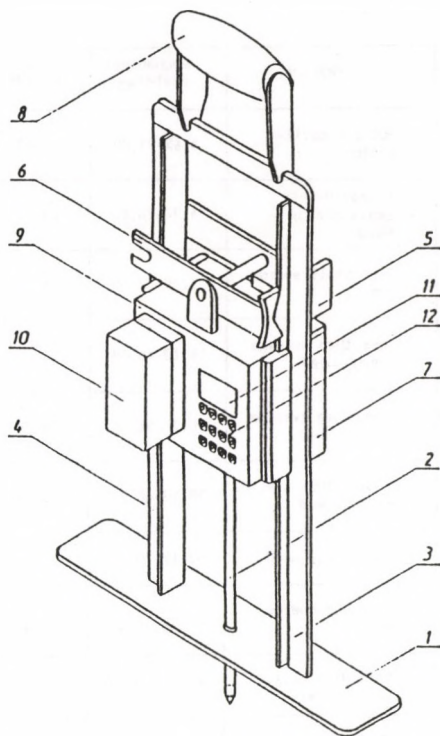

FIGURE 3.  
*System model of cultivation energetics energy demand of  
cultivation change sub model*

### MEASURING DEVICE DEVELOPMENT AND METHOD

In this novel examination approach it was necessary to form a new measuring examination system of tools in order to derive the soil physical mechanical characteristics (moisture content and compactness) based on the production field in situ tests and the inner relationships of tillage energetic interactions. To determine the common and same production field point values of soil moisture content and compactness an In Situ Soil Tester (with 3 T System fancy name) called Electronic Layer Indicator was designed (Fig.4,5).

The instrument measures the related values of soil moisture content and penetration resistance, compactness in situ. The apparatus making use of easily handled and specially designed mechanical and digital elements has three versions which measure the related values of soil moisture content and penetration resistance of cropland by every 1 cm of the 0-40, 0-60 and 0-95 surface layer intervals, calculate the algebraic



- |                                  |                             |
|----------------------------------|-----------------------------|
| 1. Floor plate                   | 7. Rail for measuring box   |
| 2. Pick up box                   | 8. Handle                   |
| 3. Pack for 1 cm advance         | 9. Elektronik measuring box |
| 4. Base frame                    | 10. RAM memory              |
| 5. Step handle in two directions | 11. Display                 |
| 6. Step handle operator          | 12. Hardware tastatur       |

FIGURE 4.

"3T System" electronics layer indicator schematic structure

mean. The instrument displays the values at every 1 cm and the mean value belonging to the examination depth interval. The apparatus measures the moisture content of soil as a part ratio of the arable land water capacity (pF 2.5) in %, the penetration resistance, compactness in kilopascal (kPa). The measured values are stored in RAM memory units, so that data can be used in computer laboratory for further evaluation, table and diagram graphical demonstration (Fig.6). The data stored in RAM memory is arranged and analyzed practically e.g. forming characteristic functions and making detailed analysis by means of process program. The measurement series can be stored in databases so that they can even be analyzed through more years by means of comparing same production field data.

#### MEASURING DEVICE - COMPUTER EVALUATION SYSTEM

The measuring results at every 1 cm of the soil section insure learning more detailed the moisture and compactness relations of the soil layers. Discrete values of fuel consumption, traction resistance, tractive wheel slip based on measurements are loaded into the hardware and software elements of the measuring device. On the basis of these discrete values and the mean values belonging to their test intervals it determines and expresses comprehension of decision alternatives by means of displaying ten (from 0 - to 9.) cultivation possibilitivalve intervals characterizing cultivation energetic category system which is shown in Fig.7.

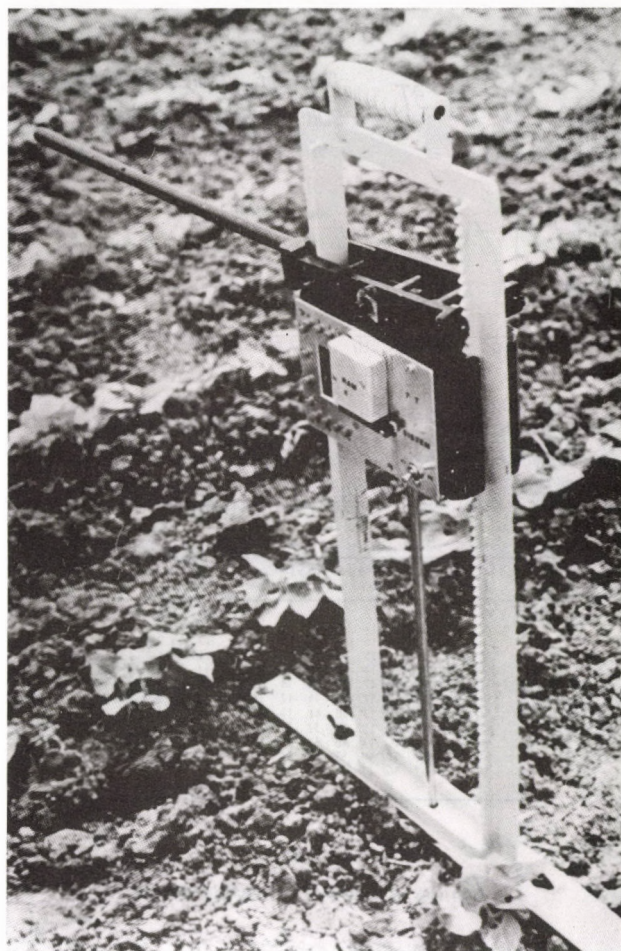

FIGURE 5.

"3T System" electronics layer indicator

#### RESULT

The further development of the results achieved it become possible to solve certain special tasks. Joining to computing and information technology systems such an arable land plant system can be formed which by making use of the most up-to-date news and data communication systems matches market relations. Recalling a concrete example in the computer based system of agricultural technology management at the Agricultural Engineering School of Gödöllő University of Agricultural Sciences the environment friendly soil cultivation and plant production of the total line of production can be organized on a consultation base matching flexibly the soil and climate needs of agricultural ecology regions (Fig.8).

In the case of satisfying this aim one can avoid or reduce the overcultivation of soils and the large energy wasting. The soil structure destruction and damage effect of soil cultivation can be reduced to minimal and in the frame of land protection the improvement of land quality will be soluble.

#### References

1. Sinóros-Szabó, B.; Kazó, B., 1979, Energy and soil physical relations of soil cultivation and their practical applicability, *Járművek, Mezőgazdasági Gépek*, vol. 12, No. 12., p. 445-449.
2. Sinóros-Szabó, B.; Kazó, B.; Sourell, H., 1992, Bestimmung der Physikalischen Wechselwirkungen des Bodens unter besonderer Berücksichtigung der Bewässerungssteuerung, *Zeitschrift für Bewässerungswirtschaft*, 27. 2., p. 168-179.

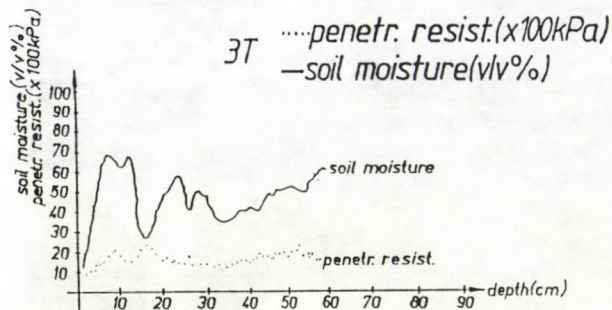

Time: 1990.05.16.

Field code: D13

Arithmetical means of soil moisture: 45%

Soil code I, arithmetical means of penetration resistance: 124 kPa

Energy code (1), tillable by extremely low energy requirement

cm	%	x100	cm	%	x100	cm	%	x100	cm	%	x100			
		kPa			kPa			kPa			kPa			
1	10	6	2	23	0	3	34	9	4	41	12	5	61	13
6	66	14	7	66	17	0	66	10	9	66	10	10	61	17
11	61	10	12	66	14	13	66	15	14	46	17	15	20	20
16	22	24	17	25	25	10	32	16	19	37	17	20	46	13
21	46	16	22	51	14	23	56	15	24	56	13	25	46	13
26	37	16	27	46	12	20	51	14	29	46	13	30	46	13
31	37	10	32	34	12	33	34	12	34	32	10	35	32	12
36	32	13	37	37	13	30	41	14	39	37	14	40	37	14
41	41	14	42	41	15	43	37	17	44	46	17	45	51	17
46	46	17	47	46	17	40	51	10	49	51	10	50	51	10
51	51	17	52	51	10	53	51	19	54	51	17	55	46	17
56	46	17	57	56	17	58	56	15	59	61	15	60	61	13
61	0	0	62	0	0	63	0	0	64	0	0	65	0	0

FIGURE 6. Results of penetration measurements

for cultivation energy	Heating	mechanical resistance	soil humidity
0	not for cultivation	4,69-75,00	6-42
1	extraordinary small energy need	4,96-30,02	10-60
2	very small energy need	9,30-37,50	24-66
3	less than average energy need	14,10-46,00	30-72
4	less than average energy need	18,75-51,56	30-70
5	bigger than average energy need	28,13-60,93	36-84
6	big energy need	42,19-70,35	42-84
7	very big energy need	51,56-75,00	40-90
8	It's difficult to cultivate	65,63-70,00	54-90
9	It's no sense in cultivating	4,69-75,00	66-96

FIGURE 7. Categories for cultivation energy

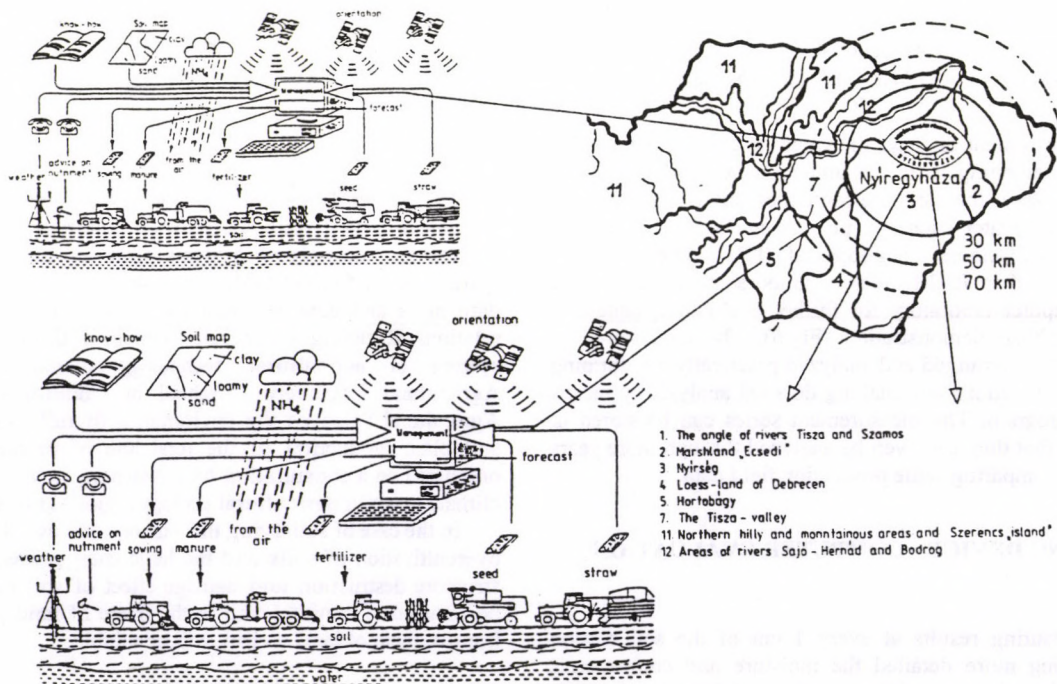

FIGURE 8. Szabolcs-Szatmár-Bereg country production zones technological management of agriculture based on satellites and computers

## PIG HUSBANDRY ON DEEP LITTER

L. MÁTYÁS - Dr. B. KULI

Hungarian Institute of Agricultural Engineering, Gödöllő  
Dr. G. MÁRAY - E. GYÖKÖS PÁLVÖLGYINÉ  
University of Agricultural Sciences, Gödöllő

### PRELIMINARIES AND AIM OF RESEARCH

Pig fattening technology on deep litter treated with bioactive additive agents is of far eastern origin. Significant reduction of odour emission, elimination of slurry production, and the compost applicability of deep litter used in more production cycles are considered as advantages.

The method appeared in Europe some four years ago.

Adaption and control experiments are being carried out in several western European countries and it is used as introduced technology in a couple of plants. In our case in the interest of adapting and examining the system elimination of slurry production a summer and an autumn experiments were set up. In the first cycle of July and August the production results lagged behind expectations as a consequence of high outer temperature, fodder quality problems and dysentery illnesses both with experimental and control stocks. That is why the course and results of the second cycle are presented in this paper. The Japanese origin molasses type SEF-C and the Finnish made sawdust-like ENVISTIM additive agents were used.

### DESCRIPTION OF PRODUCTION TECHNOLOGY

In the light weight structure fattening building 16 square meter boxes were formed for the two experimental groups with heightening the side grids. In the course the first experiment the poplar and acacia sawdust litter compacted to 60 cm layerwidth was filled up with fresh material to 80 cm height. In each experimental boxes 2 AVEVE type automatic feeders combined with nipple drinkers were mounted. For 8 pigs out of the control stock one original 8 square meter box was kept with the traditional automatic feeder and bowl type drinker without any modification. At the other 8 pigs of control stock AVEVE automatic feeder were also installed after four weeks. Water meters were installed in the boxes. To monitor manure decomposition process temperature sensors were placed in the litter and concurrently the box temperature and humidity values were also recorded. According to the technological prescriptions after placing the agents the litter were regularly turned over by man-power.

### THE RESULTS OF RESEARCH

Before housing pigs the deep litter which warmed up to 40-50 Centigrade in the previous fattening cycle was turned over partly in order to ventilating through and partly to check and inspect the heat sensors. Due to this the initial litter temperature started at 26-36 centigrade and rose to 40 centigrade in some ten days and remained uniform.

The humidity in the room with additive applied deep litter were not appreciably higher than in the control room.

Taking into account the first fattening cycle also the deep litter with additives got damp only in the manure corners to the end of cycles in spite of the 1400 kg/m<sup>3</sup> litter manure load. That was because the decomposition heat evaporated the surplus moisture. According to the tests of the National Institute of Animal Health salmonella and E.coli bacteria were not found in the litter samples. The water consumption of pigs using combined automatic feeders was 33-39 % of that of pigs with bowl type drinkers (Fig.1).

At the end of the 85 days fattening there was no significant difference between the production results of the control and deep litter stocks. Daily weight gain for the whole cycle was 612-652 g while the feed conversion efficiency was between 3.52 and 3.72 kg/kg (Table 1). It is rather surprising that on the deep litter treated with SEF-C the sows had higher weight gained in all the three weighing than the barrows with the respective values of 7.4, 11.0 and 8.6 %. On the litter treated with ENVISTIM the sow had 19.6 % higher and 13.3, 3.1 % lower weight gained respectively. In the control groups according to the usual trends the daily weight gain by gilts was lower with a value between 13 and 38 % in 5 cases, however at a group of the summer cycle the value was only 3.5 % less. It seems that the heat generated in the deep litter declined the weight gain by barrows and raised that of gilts.

### EVALUATION OF RESULTS

The physical state of deep litter was appropriate in a long part of the cycle. However, at the end of cycle the manure production rose and the litter temperature decreased due to the outside cold weather so that the manure corners started to moisten. Nevertheless the animals were not cold in spite of the 12-14 °C room temperature. While in the boxes without litter the animals huddled together due to the cold weather of November and December and uninsulated building walls. The advantage of automatic feeders with nipple drinkers to the bowl type drinker was experienced through the water consumption of about one third. The daily weight gain and feed conversion efficiency were identically favourable with both the experimental and control stocks, there was no significant difference. On the basis of the results and experiences of the examinations one can conclude that the biologically activated deep litter can be used through some 8 months in two fattening cycle in the case of stocks replacing each other and continuous litter loading and treating. The comfort feeling and health state of pigs proved satisfactory on additive treated deep litter. The opinions stating that manure loaded deep litter is favourable for propagation of different microbes did not proved true. Consuming sawdust caused no digestion troubles. The new keeping technology is less environment polluting and more comfortable for the animals than the liquid manure system. To keep the optimum litter state need however more attention and more manpower. The operational cost of its is also higher than that of the traditional system.

In the circumstances, however, when the environment conservation and protection of animals become more and more important comparing to the slightly higher production cost the deep litter system is a real technology alternative.

### SUGGESTIONS

For the further larger scale fattening:

- turning over the litter and mixing in the additives should be mechanized at least in a minimum level, in the Netherlands small rubber caterpillar track dredger machine is used for this purpose,
- in the interest of aerobe decomposition the litter handling prescription should be kept strictly,
- only such type of watering system can be used where the water can not get to the litter (e.g. combined automatic feeder is right),
- it seems practical to examine applicability of other agricultural byproducts like e.g. straw cut and the possibility of reducing the quantity or replacement of expensive import additives.

Table 1.

**Results of production in the autumn 85 days fattening cycle**

Mark and number	Average daily weight gain [g]			Average daily feed intake [g/pig]	Feed conversion efficiency [kg/kg]
	barrows	gilts	all		
SEF-C 14 db*	618	671	652	2294	3.52
ENVISTIM 15 db	651	631	641	2299	3.59
Control-1 8 db	661	529	612	2275	3.72
Control-2 8 db	685	595	629	2277	3.62

\* one animal was excluded from evaluation because of illness

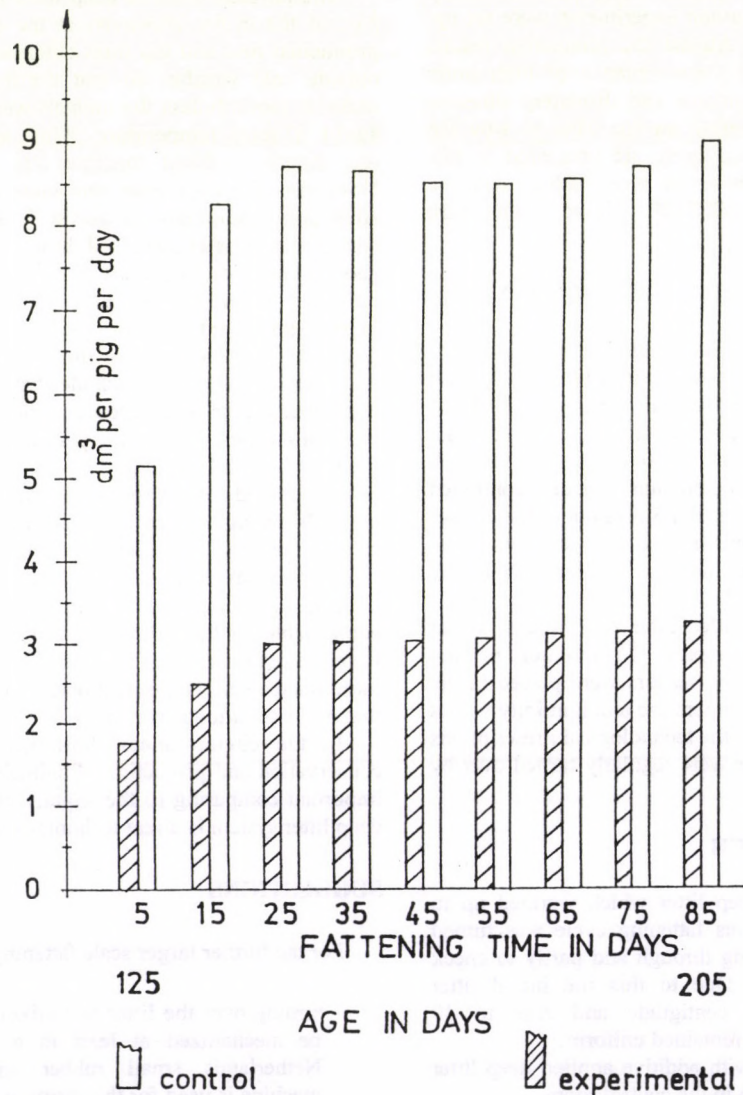

FIGURE 1.  
Daily water consumption

## AUTOMATIZATION OF MILKING DEVICE CLEANING PROCESS

Dr. L. TÓTH - Dr. J. BAK - J. BOLYÓS  
Hungarian Institute of Agricultural Engineering, Gödöllő

### INTRODUCTION

The milkmen and farmers has a hard job in the course of milking as they are milking through 6 to 8 hours a day and cleaning, disinfecting the apparatus 1 or 2 hours daily. That is why the robotization and automatization of milking seems economical. Upto now researcher has proved the reality of automatizing each step. Through the long time milking it is the possibility that microbes get inside the milking device from the air and udder and udder surface and they could spread significantly. A well operating milking device does not has any traumatic effect, but the incerrectly operating one does. In addition the milking device would transmit contaminations and infections from one udder to the other. To prevent it the rinse of milking device, the thinning of seeds are necessary at the taking over the milking device from one cow to the other. It holds for both traditional and robot milking apparatuses. Therefore the goal was established as to develop an electronic, automatic control unit, which performs intermediate rinse without human intervention, only with the supervision of milkmen.

### OBJECTS

Two problem group raised by the cleaning of milking apparatus:

- 1.) The cleaning of the wholw milking system regularly to avoid seeds increase.
- 2.) Flushing through the milking apparatus between cows following each other in order to minimalize of possible infection.

In the cleaning it is a principal task to perform as quick as possible and with so small amount of material, energy and water as the contaminating material should be the possible least amount for the waste handling. In the course of cleaning practically four main parameters should be satisfied. They are the followings:

- 1.) duration,
- 2.) mass of chemicals (concentration),
- 3.) temoerature,
- 4.) mechanical effect of cleaning liquid on surface i.e. flow intensity (Fig.1).

They had to be reevaluated for the flushing through the milking device:

- maximum 5 minutes flushing through time,
- less than 1 litre cleaning water,
- a 40 centigrade tempoerature limit,
- no chemical in the flushing liquid,
- according to the necessity the maximal mechanic effect.

### RESULTS

At the rinsing the milking device the greatest question is the 25 times difference in the flow cross section (the ratio of the collector and the long milk line sections) (Fig.2). At the expanding cross sections the decrease of the flow velocity of washing liquid is rather considerable. The milking devices has 1300-1500 cm<sup>3</sup> inner surface. The rinsing volume is 500-950 cm<sup>3</sup>. The common cross section area of the long milk line is in

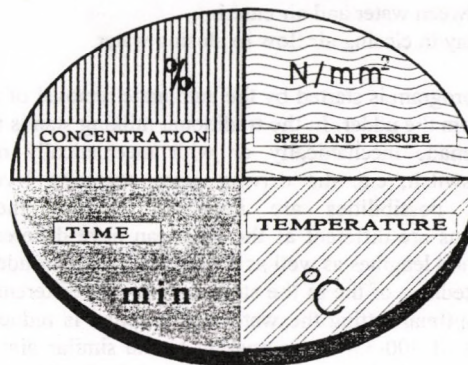

FIGURE 1.  
Parameters of washing system

2 cm<sup>2</sup>. The 4 pieces short milk hoses, the teats and collector have 2.5, 18 and 57 cm<sup>2</sup> cross section, respectively.

It almost the only possibility to enhance the pressure difference by using overpressure. This makes air and water inlets was applied to the long milk line of the milking device. Through this joint after the milking device disconnection water and air mix was pumped in. Therefore the cleaning liquid flows in the opposite direction to the milk. Of course that time the long milk line should be closed after the inlet part. The cleaning starts with water introduction followed by the air in the remaining water is swept out by the air blow from the milking device. It was considered acceptable if there were fewer than 10.000 seeds per millilitre in the control ronse liquid at the control bacteriology test.

$$D = 20 d$$

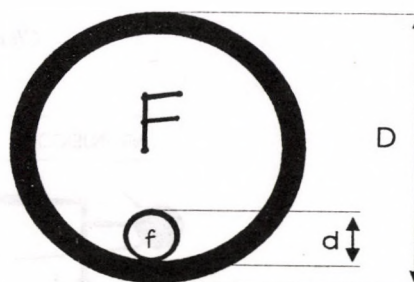

FIGURE 2.  
Cross section area ratios

The technical specifications are as follows:

- the rinse water temperature is between 30 and 40 centigrade (there were no significant change, but it is practicable to come near 40 °C physiology reasons);
- liquid pressure was 0.4-0.6 MPa;
- compressed air pressure was 0.5-0.7 MPa;
- in the measurements the air and liquid ratio in the mixture was changed between 2 and 10.

The rinse time was 5-10 seconds.

In order to set the charge time and value precisely an electric governor was developed. Later it was extended to more channel and get into application with traditional milking equipment types. The governor give possibility to change durations, like

- whole period,

- between water and air entering,
- delay in closing air flow to closing water.

The program is started by the automatic removal of milking device from the udder. In the traditional milking stands the start can be made mechanically or with mechanically operated electric switch, e.g. the driving gates operating lever. The adjusting possibilities are necessary because the local installations are different as the lines can have different cross sections and lengths as well as the contamination of udders and the infectedness of the in the stock can also be different. In the case of optimal setting the water consumption is reduced with an extent of 300-350 % comparing to the similar aim known solutions. In further great advantage that the less quantity contaminated liquid can be handled more economically.

### CONCLUSIONS

The rinsing apparatus developed by the Institute research works with small amount of water and minimal disinfecting chemical. It is solved through speeding up the rinse liquid by overpressure air so that the mechanical effect being a need of cleaning is increased in a significant extent. The less cleaning chemical and water consumption and the reduced energy need not

only result in cost reducing but in environmental conservation as less contaminating material is produced at cleaning and can be placed in the environment more cost effectively. The control unit of the device consists of integrated circuits and can be attached either to milking robots or milking devices of high level automatization.

### References

1. Bak, J.; Liptay, T. and Tóth L., 1989. Investigation of biological parameters aiming the development of computer controlled feeding and milking robots. Report on thesis. Technical Institute of Agricultural Engineering, Gödöllő, Hungary.
2. Tóth, L., 1990, The automatization and electronization of animal keeping, Technical Institute of Agricultural Engineering, Gödöllő, Hungary.
3. Tóth, L.; Liptay, T.; Bak, J., 1992, The Hungarian milking robot. Prospect for automatic milking, Pudoc Scientific Publishers, Wageningen, The Netherlands.
4. Tóth, L., 1989, Newest results in the field of increasing efficiency of milking, Akadémiai Kiadó, Budapest, Hungary.
5. Tokar, M.; Tóth L., 1989, Utilization of micro-electronics in the animal breeding, (Primenyényie mikroelektroniki u zsvivotnovogsztve), Urozsáj, Kiev (ZIZP).

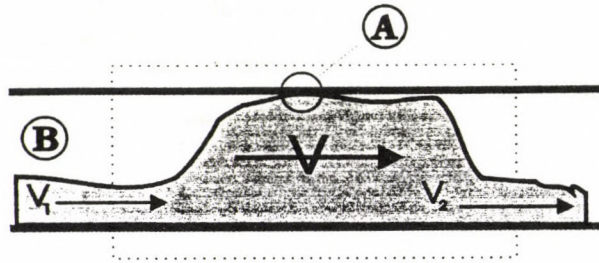

FIGURE 3.  
*Characterising giant bubbles*

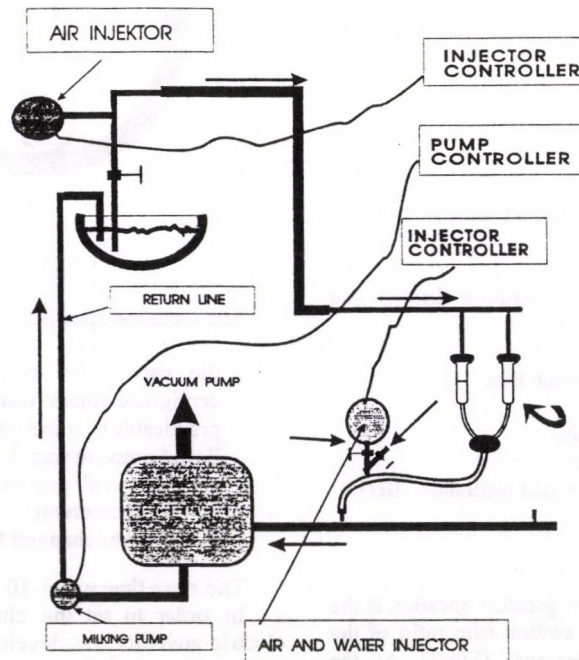

FIGURE 4.  
*Overview of the cleaning system*

## COMPARATIVE TEST WITH DIFFERENT BIO-DIESEL FUELS IN TRACTOR ENGINE

Dr. I. J. JÓRI - Dr. M. SZENTE - G. RADVÁNYI  
Hungarian Institute of Agricultural Engineering, Gödöllő

As a part of "Alternative fuels for engine" R and D work which was support by OMF B and four Ministry (KHVM, KTM, FM, IKM) we have done a comparative test with diesel fuel, RME (from Austria), RME (Győr) and rape oil mixture (Schur) in tractor engines (MTZ-80 and Zetor 160.45).

The aim of this test was to evaluate the fuels (the fossil fuel and the three different kind of bio-fuels) based on the tests of agricultural engines. The engine tests were done by the tractors main PTO performance. One of the engines, built in tractor MTZ-80 was natural aspirated and the other was turbocharged, built in tractor Zetor 160.45.

The engine loading was made by engine dynamometer, type Schenk D 630-1h.

The tested fuels features' are the follows:

Fuel	Energy capacity MJ/kg	Density kg/dm <sup>3</sup>	Viscosity mm <sup>2</sup> /s
Diesel	42.7	0.842	5.5
RME (from Győr)	36.0	0.881	10.4
RME (from Austria)	35.4	0.880	7.0
Rape oil mixture (Schur)	36.2	0.890	23.7

The results of the bench engine tests were valued by power, fuel consumption and the energy consumption (see 1 and 2 Fig.).

### *Evaluation of the test result made by natural aspirated engine (engine type: D-240)*

On the strength of the test results we can establish, that when we ran the engine with bio-fuels, the maximum power was lower than the case of Diesel fuel. The rate of decreasing is 1.5-2%. There is no significant difference between the maximum engine powers using different bio-fuels.

To investigate the changes of the fuel consumption there is a better way to follow the specific fuel consumption. For this reason we demonstrate on the Fig.1 the different specific fuel consumption curves of the functions of engine power, using the Diesel and the different bio-fuels.

It can be seen, there are differences in the specific fuel consumptions at the maximum engine power. These differences are coming from the differences between the densities, and the lower energy capacity of the bio-fuels.

To characterize the efficiency of the consumption we determined the equivalent energy consumption values based on the specific fuel consumption. It is shown on the Fig.2.

As seen the specific energy consumption of the engine is lower with different bio-fuels than Diesel one. The difference is 1-4% and it depends on engine loading and on kind of fuel. Otherwise we couldn't find significant differences between the result with different RME and the rape oil mixture fuels.

As we have detailed before, according to the test results with different fuels, the specific energy consumption decreased in addition to engine power. It could happened if increased the injected fuel volume and improved the efficiency of the combustion, because of the lower energy capacity of the RME and the rape oil mixture. The Fig.3 shows the change of the fuel delivery.

As can be seen, the fuel delivery increased nearly to same extend in case of all three bio-fuel. The reason for this may be the less clearance leakage because of the higher viscosity or the change travel of pressure wave in injection line. The increase of fuel delivery was 4-5% in whole engine speed range.

### *Evaluation of the test results made by turbocharged engine (engine type: Z-8602)*

There were bigger differences in maximum engine power during the test of turbocharged engine than it was with natural aspirated engine.

The maximum engine power with different RME and the rape oil mixture (Schur) fuel decreased by 3-4% compare to engine power with Diesel fuel. At the same time we couldn't find significant differences between the maximum engine powers with different kind of bio-fuels.

In the values of maximum engine torque there were big differences during the test turbocharged engine also. These differences are disadvantage to RME and rape oil mixture (Schur), because the value with diesel fuel was better by 6-7%.

The hourly fuel consumption increased by 6-7% when the bio-fuels were used. Because of the higher hourly fuel consumption increasing was bigger in the case of higher hourly fuel consumption. The specific fuel consumption increased by 10-11%. The Fig.4 is demonstrates the specific fuel consumption curves and the Fig.5 the specific energy consumption curves.

The specific energy consumption increased by 4-6% when the engine was run with rape oil fuels. On the other hand we didn't find valuable differences between the results of the test made by bio fuels.

In view of change of fuel delivery (Fig.6) we can see only 1-2% difference between the results of Diesel fuel and the rape oil fuels. This difference is less than the difference in the test with natural aspirated engine was.

Summing up the results of the test made by turbocharged engine we can find that we need except the decreasing of the engine power by 3-4% and the increasing of the efficiency by 4-6% when we use rape oil fuels for Diesel engine.

Based on the results of the bench engine test with different kind of fuels, Diesel fuel, RME - from Austria and Hungary and rape oil mixture (Schur), we can conclude that:

- The operation of the agricultural tractors (engines) has no any limitation with rape oil fuels,
- Using different rape oil fuels the engine power decreases by a few % compared to Diesel fuel. Otherwise the energy consumption and the efficiency of the combustion becomes a bit better,
- At the test condition was no any significant differences between the results getting from RME's and rape oil mixture (Schur).

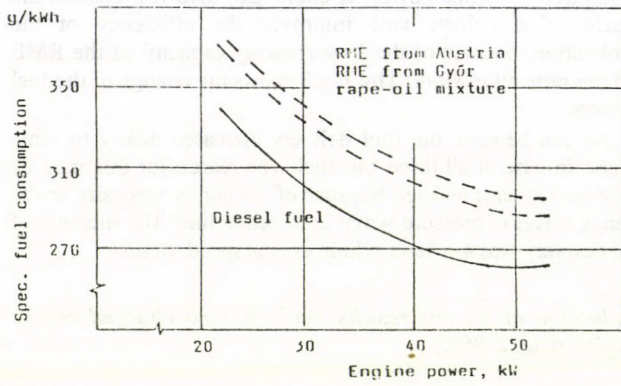

FIGURE 1.  
Trend of specific fuel consumption  
Einige type: D-240

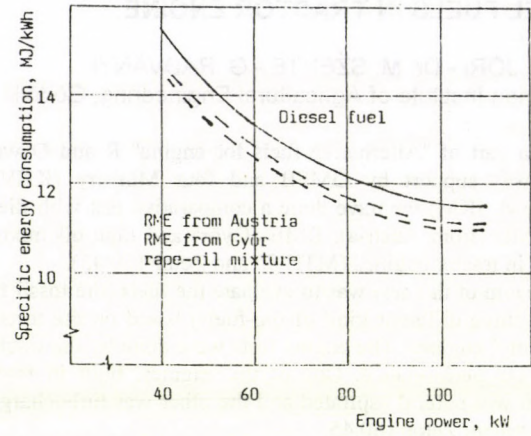

FIGURE 2.  
Trends of specific energy consumption  
Einige type: Z-8602

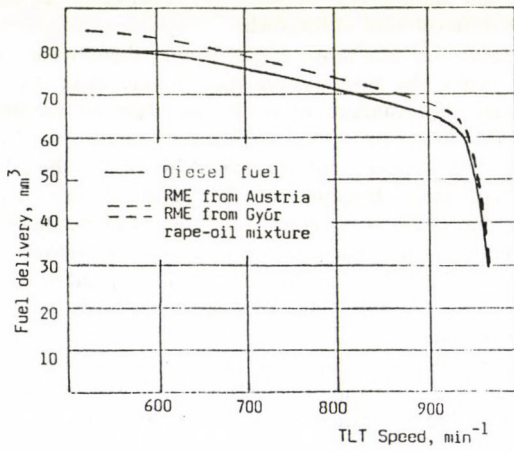

FIGURE 3.  
Trends of fuel delivery  
Einige type: D-240

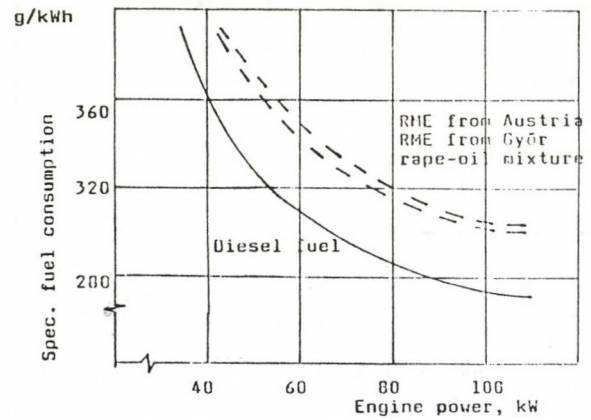

FIGURE 4.  
Trend of specific fuel consumption  
Einige type: Z-8602

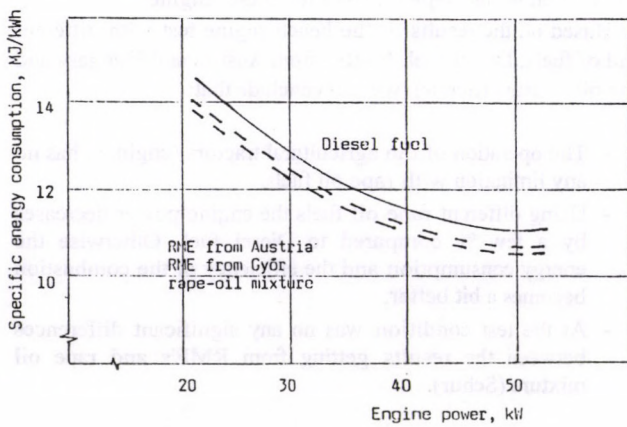

FIGURE 5.  
Trends of specific energy consumption  
Einige type: D-240

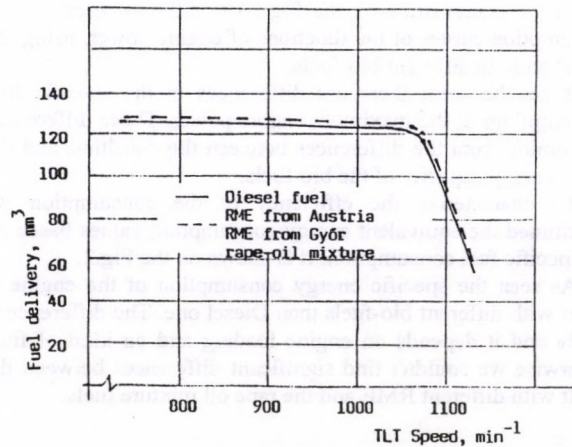

FIGURE 6.  
Trends of fuel delivery  
Einige type: Z-8602

## DRUM CONCAVE SUPPORT FORCES AND THE DRIVING FORCE OF DRUM

Dr. P. SOÓS - Dr. ZS. SZÜLE - Dr. J. KOLTAY -  
Dr. K. PETRÓCZKY  
University of Agricultural Sciences, Gödöllő

At the development of threshing implements a prosperity can be observed worldwide. The experiments aims mainly to improve threshing quality and to reduce power need. The investigations are in wide scale. Partly already existing designs are involved in the experiments, but several new solution also came out.

For the reliable design and development of threshing equipment it is important to know the forces acting on drum concave and the driving force of drum. According to our assumption the continuously changing concave support force can serve as a basic signal at the monitoring automate development.

From the sixties several measurements were carried out in some countries including this country in order to determine threshing and chaff cutting drum moment requirement. Concerning concave support forces there were no measurement in this country.

That is why it was fixed the measurement of forces acting on drum concave and the drum driving force concurrently as goal with basic research character. This includes also measuring both shaft decline and twist and acceleration moment and power need.

The work has four main parts such as:

- exploring, analyzing and evaluating relevant literature,
- preparing measurement,
- laboratory measurements,
- arable land in situ measurements.

In 1992 the works in point a) b) were conducted.

Arable land measurements are wished to be carried out at wheat and corn harvest with Class Dominator 106 combined harvester. The scheme of force measurement is shown in Fig.1.  $F_1$  support forces at the concave front and  $F_2$  support forces at the concave back as well as the  $\omega$  angle velocity should be measured.  $F_1$  and  $F_2$  forces on the left and right hand side of the drum are transmitted by two pairs of rods to toggle lever. The strain gages are fastened to the pushbar mounted between the angle levers and the handle lever.

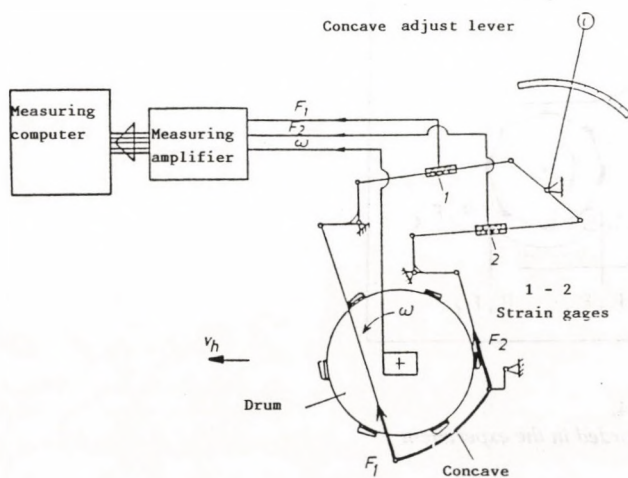

FIGURE 1.  
Measurement scheme of drum concave forces

The concurrently measured  $F_1$ ,  $F_2$  and  $\omega$  signals get to the measuring amplifier and to the measuring computer from here.

On the basis of experiments elaboration of expressions can be expected which have not been known so far. Assumably they would be appropriate to calculate the true loads of threshing device more accurately compared to the previous methods.

Between the two world war in Hungary there was a developed agricultural machine manufacturing known internationally. Threshing machine as most important implement of that time farming was manufactured by more factories. The threshing machines made by HSCS, EMAG and MÁVAG and driving and service fittings necessary to operate threshing machine were also famous.

The social transformation following the second world war two did not preserved neither the agricultural machine industry and the previously prospering agricultural machine industry worked with different profile and in different ownership and organization system. The other characteristic phenomenon of the era was the fast technical development both in east and west. The previous mower, harvesting and threshing machine technology started to be replaced by the technology based on towed and later selfpropelled combined harvesting threshing machine. After the United States of America Western Europe and the Soviet Union also began to develop and manufacture the new leading machine. The Hungarian threshing machine designers and manufacturers got the possibility to manufacture the Hungarian harvesting-threshing machine in the frame of the First Hungarian Agricultural Machine Factory (EMAG). The first Hungarian harvesting-threshing machine (AC-400) were made in 1950.

The Hungarian harvesting-threshing machine development and manufacturing had end in 1961-62 on the basis of political decision in spite of its home and international successes. The produced machines were involved in comparative examinations in 1962. Working quality and energy measurements were carried out. Machines of that time were loadable up to 5 kg/s total mass transmission rate. The measurements were continued in cereals by means of electro-tensometric force measurement.

As an example a measuring data collection is shown for SzK-4 combine drum moment frequency trend in operation at wheat harvesting (Fig.2). These data gave significant help to the further development.

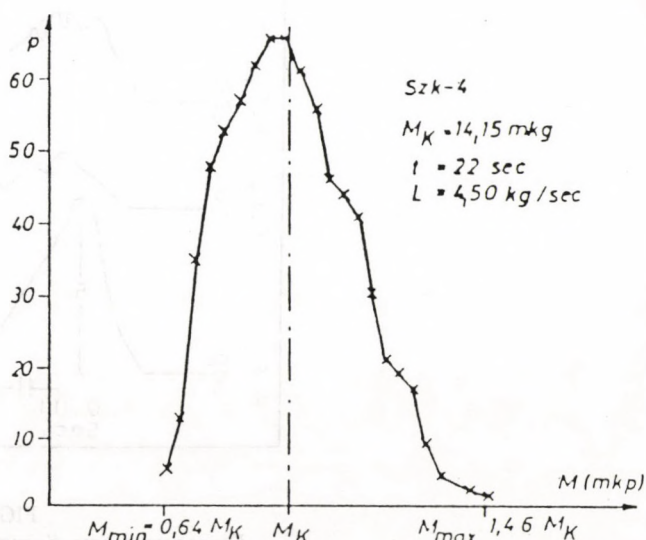

FIGURE 2.  
The moment frequency distribution at 4.5 kg/s drum transmission rate (SzK-4)

On the basis of experiment carried out in the USA in 1974 the shelling work of drum, the grain crack and the concave support forces can be analyzed. The experiment was conducted with 24 % moisture content eared maize in laboratory using the measuring apparatus developed for this purpose. The drum revolution was 500 rpm the drum gaps were 37 mm in the front and 19 mm in the back. The corn ears were fed by hand into the drum.

- There were three ways of feeding, such as:
- the axis of ear were perpendicular to the drum,
  - the axis of ear were parallel to the drum,
  - random feeding.

Pictures were taken from ten positions of ear fed by means of a camera suitable to motion analysis. The ten positions of the corn ear are demonstrated with Fig.3. The change of forces in time with parallel feeding is shown in Fig.4.

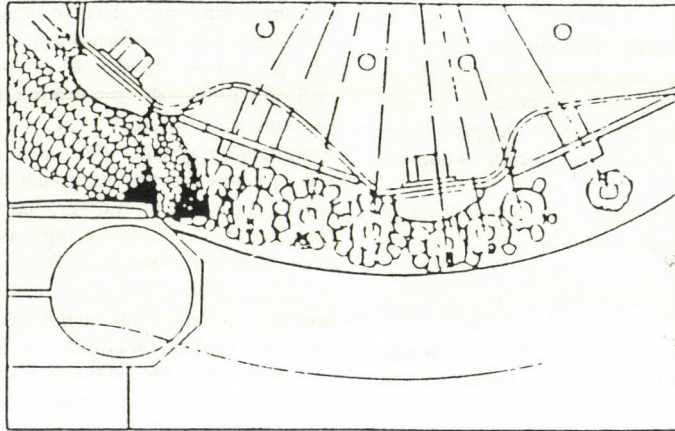

FIGURE 3.

*The ear of corn fed between the drum and the concave (USA, 1974)*

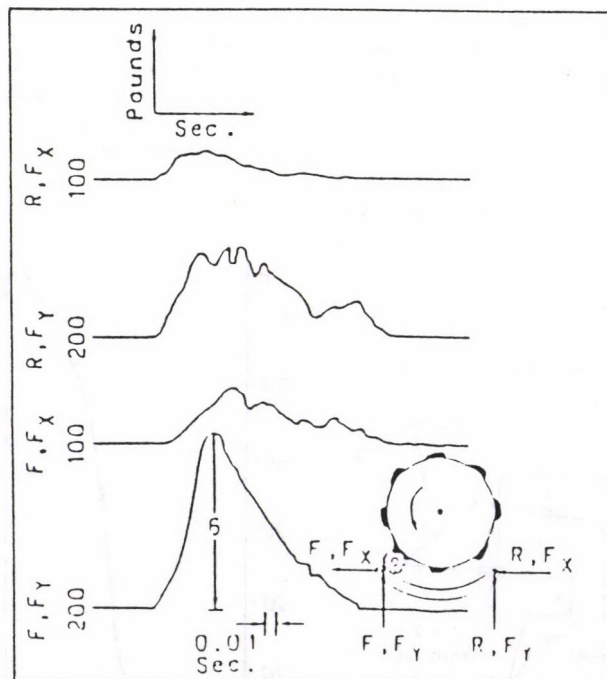

FIGURE 4.

*Force versus time diagram recorded in the experiment*

# APPLICATION OF THERMOGRAPHY IN AGRICULTURAL ENGINEERING RESEARCH

Z. PAPP

Hungarian Institute of Agricultural Engineering, Gödöllő

In several fields of agricultural engineering research, and particularly at the investigation of thermal phenomena, the surface temperature and the formation of temperature distribution in time and space are important information. The infra-television makes possible to take pictures of surface temperature and its distribution and change in time and space as well as the computer processing of temperature characteristics.

In the followings the method will be demonstrated through some real examples emphasizing the novel measuring and evaluating techniques.

## DESCRIBING THE METHOD

The THU 782 system consists of 5 units the image recorder and the evaluating system. (Fig.1 and 2).

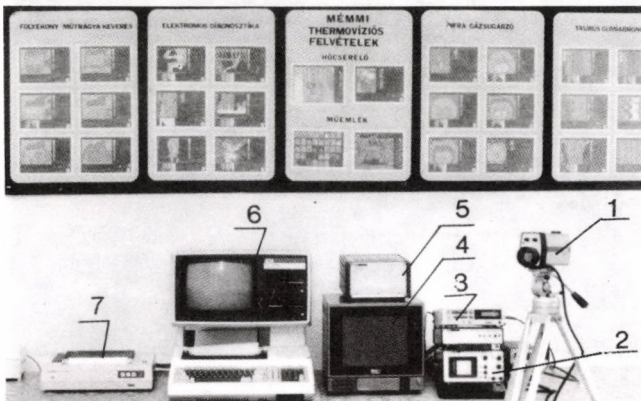

- 1. Scanner
- 2. Display unit
- 3. Video recorder
- 4. RGB Monitor
- 5. A/D transformer
- 6. TC 800 computer (with image processing program)
- 7. Colour printer

FIGURE 1.

AGA THERMOVISION® 782 SW Digital Image Processing System

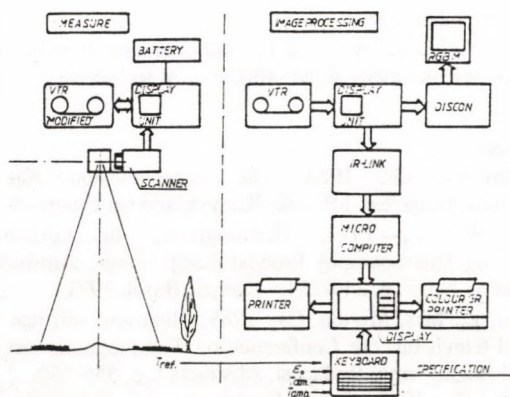

FIGURE 2.

Simplified Block Diagram

The most important element of system is the scanner the detector of which senses the 3.5-5.6 μm radiation and form a

picture by a double prism. The prism system scans the picture pixel by pixel and transmit to the infrared detector which transforms it into electric signal. The signals got such way are partly transmitted to a cathode tube where the monitor has traditional television picture and otherwise they are recorded by modified video recorder.

The analogues picture signals fixed at computer processing are digitalized and the pictures are stored on floppy disks.

The image processing program (DISCO 3) ensures the following processing possibilities:

- Quantitative determination, temperature measurement,
- Finding the isotherms - identical temperature places,
- Temperature distribution determination for the whole picture or for selected area,
- Determining temperature values of horizontal and vertical sections (thermal profiles),
- Determination of difference of two thermograms of time changing processes,
- Scaling heat details,
- Colour coding according to taste (maximum 36 tones),
- IR-image filtering.

## EXAMPLES OF THERMOGRAPHY APPLICATION

### Model level investigations of drying processes

Thermal properties of corn and tobacco were investigated in different phases of model like drying. The measuring diagrams of examination processes are shown in Fig.3 and 4.

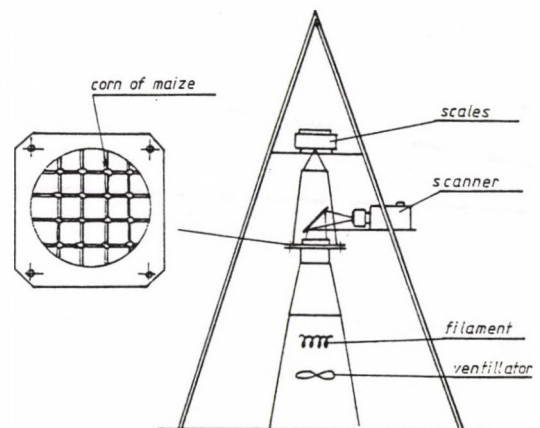

FIGURE 3.

Investigating drying process of maize

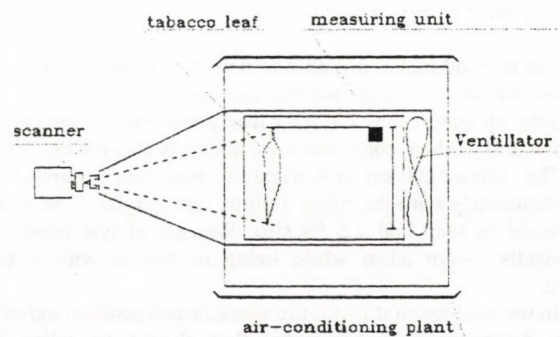

FIGURE 4.

Examination of drying process of tobacco leaf

Surface thermal characteristics in relation to the moisture content and drying time of corn grains were investigated. Besides the periodical detection of temperature the mass change was also measured as a function of time. In the course of modelling there existed the possibility to adjust air velocity and drying temperature continuously.

At the tobacco leaf drying process the leaf surface temperature was detected while the temperature and vapour content was adjusted and the mass change measured. Typical evaluation results of the measurements for the two cases are demonstrated in Fig.5 and 6.

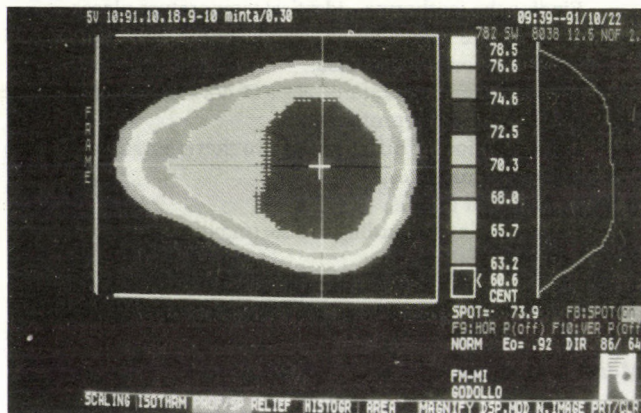

FIGURE 5.

Horizontal and vertical thermal profiles of corn grain surface temperature

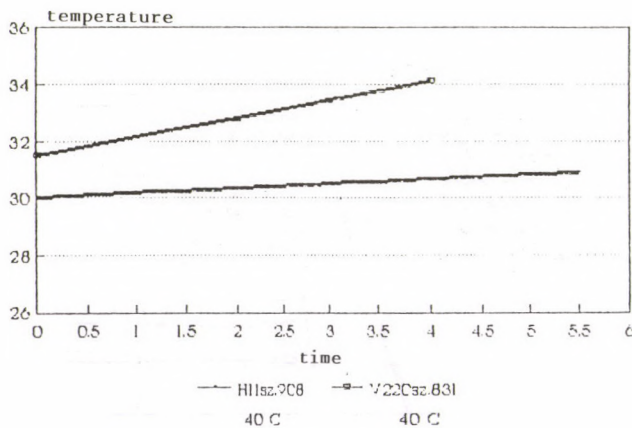

FIGURE 6.

Tobacco leaves surface temperature as a function of drying time

#### Investigation of agricultural tyres

The method makes possible to detect such type of defects as disjunction of layer and internal ruptures. In these spots local warming up occurs due to higher heat generation by the internal friction and the heat conduction capability is also lower.

The infratelevision investigation was being carried out simultaneously with the quick fatigue test of tyres. The wheels subjected to load had 2.5 % slip. Records of tyre-treads and side-walls were taken while being in motion with 4 km/h speed.

In the evaluation it is not the absolute temperature rather the local deviation from symmetry that should be taken into account. This deviation could be even higher by 1.5-4 °C depending on the inner disjunction of layer or internal rupture.

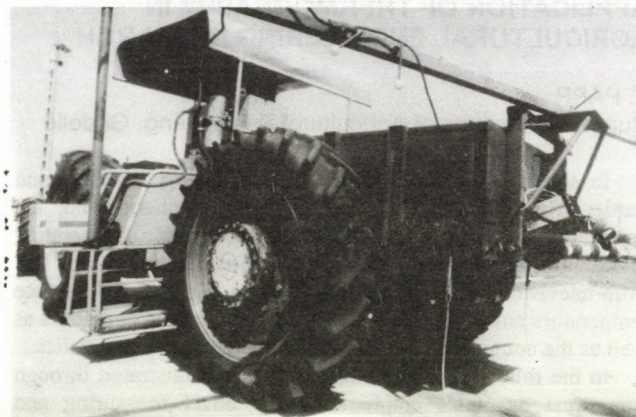

FIGURE 7.

Taking records on the fatigue place

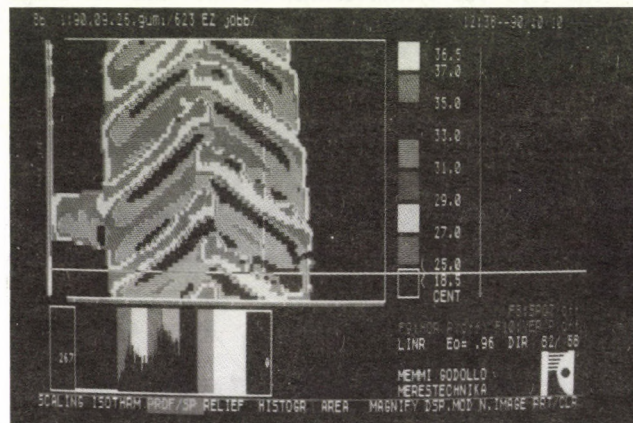

FIGURE 8.

Temperature photograph of tyre (zoomed in part)

#### CONCLUSION

- Infratelevision measuring technique is widely applicable to continued examination of machines and technologies of agriculture,
- The investigations make possible to analyze such processes which could be examined difficultly, costly or by no other means,
- The tools available and the complementary units make possible the many sided utilization of technique.

#### References

1. Rudowsky, G., 1982, The infratelevision and its applications, Budapest, Műszaki Könyvkiadó (in Hungarian)
2. Schurek, K., 1974, Thermography in Agricultural Engineering Thermography Proc.Ist.Europ.Congr., Amsterdam, Bibl.Radiol. No.6., p. 249-254. / Karger, Basel, 1971.
3. Papp, Z.; Mrs. Marton, Cs., 1989, Plant and soil test with infra-red television, 6th Conference on Thermogrammetry and Thermal Engineering, Budapest, Abstracts I. p. 555-559.
4. Papp, Z., 1989, Infrared cameras in agriculture, 6th Conference on Thermogrammetry and Thermal Engineering, Budapest, Abstracts II. p. 543-547.
5. Papp, Z., 1988, Examples of agricultural purpose application of thermovision, Engineering development results, AGROINFORM 09 No. 301. (in Hungarian)

## EXAMINATION OF GRAIN MILL FOR SMALL SCALE FARM

Dr. GY. GYÖRFY

University of Agricultural Sciences,  
Agricultural Engineering College, Mezőtúr

The choice of small scale crushing mills is rather wide on the market. According to their design they are fundamentally (different shape) hammer and blade types. The offer of cylindrical (shattering) and disk type mills is lower. The mills has certificates of ergonomics, work and technical safety, however, their working quality and energy examination usually fails to be completed.

Investigation of small scale hammer mills is important in the point of view of theory, as well, since the speed of crushing element is significantly less than that of large output mills (in our case the speed at the type FV-III-S is 27 m/s instead of 70-100 m/s). Even the question arises to the rules discovered so far how they are valid for small scale mills.

Examinations were conducted on the available FV-III-S type, SALINA made crushing mill (manufacture number is 19605).

The technical specification of machine (supplied by factory):

- Nominal power requirement: 550 W/220 V
- Revolution speed: 2840 rpm
- Mass: 22 kg
- Shape of hammers: star
- Number of hammers: 10 pcs
- Hopper volume: 10 litres
- Screen hole size: Ø3; Ø4; Ø5
- Milling output rate (maize, Ø3 screen): 60 kg/h

Wheat and corn produces were included into the investigations. The moisture content of produces were determined by the KFO Laboratory of College. THYR-2 type vibration sieve was used to separate the groats fractions. Fraction masses were measured with 75405 type OWA LABOR scale of 0.1 precision. The milling power need was measured by electric power meter. The tests were carried out with different screen hole sizes (3, 4, 5) in one loading stage repeated three times.

Groats were dissociate into 6 fractions (by using 0, 0.2, 1, 1.6, 2, 3 mm sieves). To investigate groats output the sampling time were measured with 0.1 second accuracy stop-watch. Sampling was made while stabilized power application. Data sheet were used for registration.

The basic data measured were processed by the tools of mathematical statistics and making use of the usual parameters and graphical solution methods of this field of science.

Data of groats dissociate into 6 fractions were processed for 22 setup variations and 3 repetition for species of wheat and corn produces.

Distributions of groats fractions according to the hole sizes of sieves are demonstrated in Fig.1 and 2. The mill with 3, 4 and 5 mm hole diameter screens produces typical fraction distribution i.e average particle size (groats module).

At maize milling ( $W=10.67\%$ ) with nominal load and 3 mm hole screen 1.50 average particle size was produced. With 4 mm and 5 mm screen 1.84 and 2.40 mm average particle size were achieved, respectively.

At wheat milling ( $W=11.60\%$ ) with 3 mm hole screen 1.60 average particle size was produced. With 4 mm and 5 mm screen 2.16 and 3.01 mm average particle size were measured, respectively. The average of particle sizes is above the desirable value. The ratio of sizes above 1.6 mm are above 40% in every case. At larger screen hole sizes it reaches the 50-70% values which is an order higher than the literature limit.

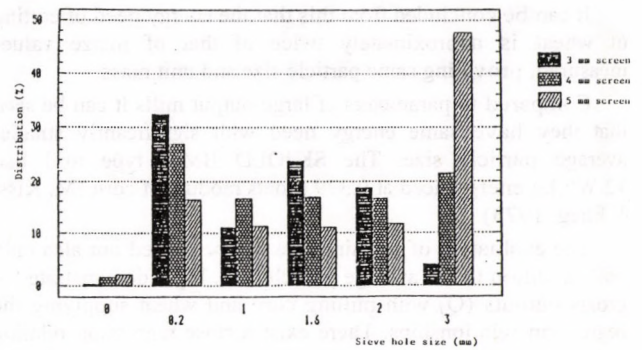

FIGURE 1.

Maize groats size distribution as per sieves

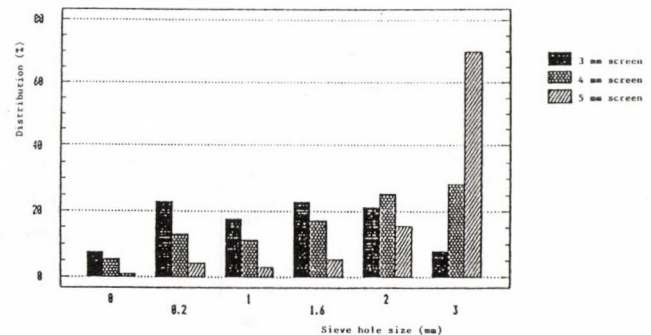

FIGURE 2.

Wheat groats size distribution as per sieves

The specific energy need of the machine changes according to the groats particle size. With increase of average particle size the specific energy need decreases. The relationships are shown by regression functions containing the correlation factors ( $R$ ) scatter values ( $s$ ) (Fig.3). There is close relation between the groats module ( $M$ ) representing the extent of cut and the specific energy consumption. With 10.67% moisture content corn the specific energy need ( $E_f$ ) can be represented by the formula

$$E_{fk} = 21.69 M^{-1} - 6.53 \text{ (Wh/kg)}$$

With cutting 11.60% moisture content wheat the mathematical expression is

$$E_{fb} = 43.56 M^{-1} - 8.72 \text{ (Wh/kg)}$$

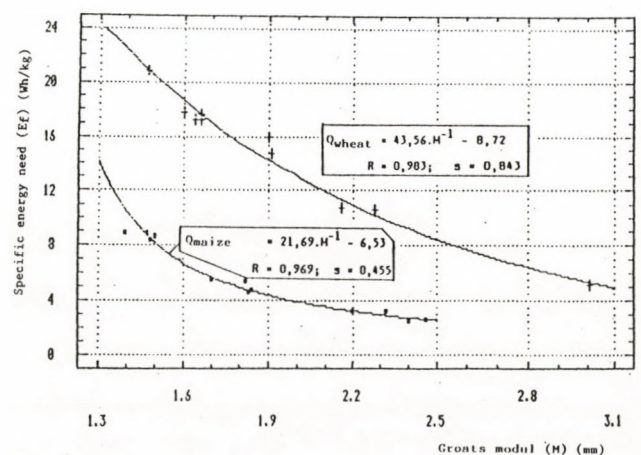

FIGURE 3.

Specific energy consumption as a function of groats module

It can be concluded from this that the energy need of cutting of wheat is approximately twice of that of maize values measured, providing same particle size and unit mass.

Compared to parameters of large output mills it can be seen that they have same energy need with significantly smaller average particle size. The SKJOLD BM-5 type mill had 12 Wh/kg energy need at 0.379 groats module of corn (M. Kiss, J. Flieg, 1973).

The evaluation of crushing rate can be carried out also only with attention to the average particle size. Fig.4 demonstrate the groats outputs (Q) with milling corn and wheat supplying the regression relationships. There exist a close regression relation between the degree of cutting represented by groats module and the groats output. The relevant expressions are

$$Q_b = 63.39 M - 77.63 \text{ (kg/h) for wheat and}$$

$$Q_k = e(2.453+1.163) \text{ (kg/h) for corn.}$$

Within the investigation limits a great difference was experienced in the groats output when milling wheat and corn. It is evident due to 550 W nominal power need and the known specific energy consumption.

It can be stated by summarizing the results:

- the FV-III-S type hammer mill is applicable to produce larger particle size groats than desirable due to the low crushing element speed,
- the specific energy consumption of cutting is high in relation to the groats size,
- the groat output and the specific energy consumption can be described by mathematical formulas as a function of average particle size of groats and a close relation can be explored.

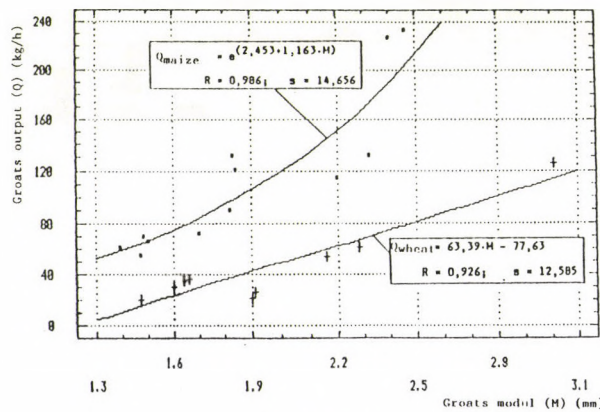

FIGURE 4.  
Groats output trend as a function of groats module

# THERMOVISION METHOD FOR THE MEASURING OF THE KERNEL'S SURFACE TEMPERATURE DURING DRYING

M. NEMÉNYI - K. KACZ - I. CZABA - A. KOVÁCS  
PANNON Agricultural University, Mosonmagyaróvár

## AIMS OF THE RESEARCH

The project started in 1990 has two basic aims:

1., To raise the degree of accuracy of the different equation systems modelling the change of state in the maize grain at drying. First of all it means that a number of constants of the different equations will be built in the equations as a function of the characteristics of the drying process.

2., Elaboration of a method to control the information given by the differential equations.

In this study the results of research aiming at the latter are outlined. There are a lot of differential equations, describing heat and mass transfers in the kernels. If we try to control these equations many problems can arise:

1., The kernels are not homogeneous, consequently we can measure only the average moisture reducing and not the moving characteristics of moisture within the kernels.

2., The second problem is the measuring of the grain temperature. The measuring tools influence the processes in the given point. On the other hand we can't measure by the measuring tools the surface temperature in all points of the surface at the same time.

Concluding from the above written a method is necessary to be elaborated to solve these problems satisfactorily.

## MATTER AND METHOD

### Testing apparatus

On the outgoing stub of the drying apparatus a joint piece, a holder card was interposed which was suitable for the corns. During the drying process the joint piece was not in contact with the outgoing stub of the drying apparatus. For measuring the weight of the joint piece, resp. the grains, an electrical balance was fixed onto the frame. Within the joint piece a synthetic net was spanned out. (Neményi and Kacz 1992)

Devices used for measuring:

- Model drier apparatus
- Thermovision: AGEMA SW 782
- Level balance: SARTORIUS

### Tested hybrids

Hybrids were given by Babolnai RT from its tests of breed adaptation.

Number	Naming
2	Domingo
9	DK 485
12	DK 524
13	Chiara
15	DK 858

### Measurements

Into the cross points of the net in the joint piece 16 grains - deriving from the cob of the same hybrid - were fixed. The change in weight and the surface temperature measurements of the tested grains were performed at intervals of 30 minutes. At the measuring the drying apparatus was stopped (for 30-50 sec.)

and a non reflecting black card was put under the grains in order to get a homogeneous background.

The temperature of the drying air was 90 C, its velocity was 0,3 m/sec. The weight of the tested grains was measured at the beginning and in the end of the drying. The measurements made by the drying apparatus were controlled in this way.

## APPRAISE THE RESULT

In Fig.1 the moisture reducing of the hybrids No. 2., 9. and 15. was represented as a function of the drying time. The curves give the possibility to rank each hybrid. Fig.2. shows the drying speeds of the hybrids No. 9. and 15.

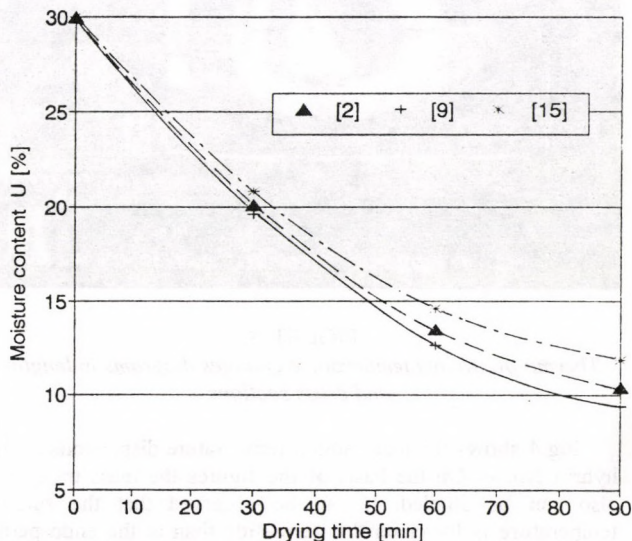

FIGURE 1.

Moisture loss of 3 hybrids as a function of drying time

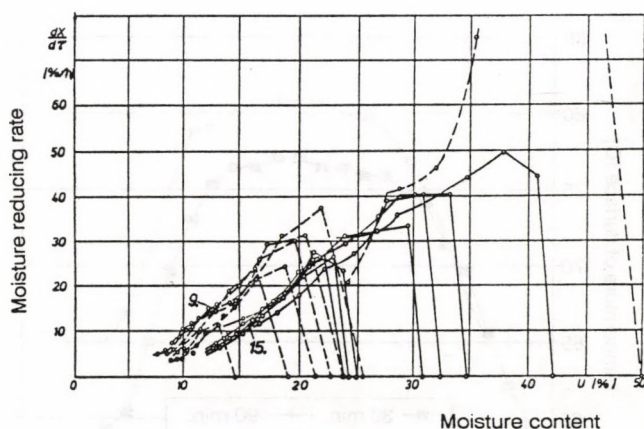

FIGURE 2.

Moisture reducing rate of a fast (9) and a slow (15) dryin hybrid

The thermal photo signs the diverse surface temperatures with different colours (Fig.3). The temperature ranges, given by the colours (in this case by shades of colours), can be seen rightwards in the picture. The temperature - dispersion curves are continued outside the contour line of the grain, because the temperature range - marked by colours - was made very narrow in the cause of good evaluation.

From the simultaneously tested 16 grains any can be chosen and on any point of it (lengthwise and crosswise) the temperature dispersion can be reproduced by the help of the AGEMA computer programme. At the foot of Fig.3 resp. on the right side, there can be found temperature dispersion curves from which the temperature differences - within temperature ranges signed by the same colour - can be read as well. The software gives possibility to visualize the temperature dispersion stereoscopically.

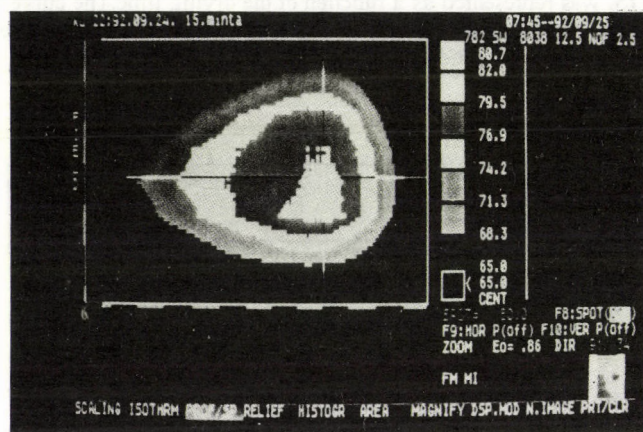

FIGURE 3.

*Thermo photo and temperature changes diagrams in length- and cross sections*

Fig.4 shows the longitudinal temperature dispersions of the hybrid No. 9. On the basis of the figures the mass transports also can be studied. It can be observed that the surface temperature is lower on the germ-side than at the endosperm. The changing of temperature gradients refers to the changing of the characteristics of water transports during the drying process. The basic aim of the tests was to establish whether on the basis of photos taken by thermovision method the temperature dispersion of the surface, resp. their changes are determinable.

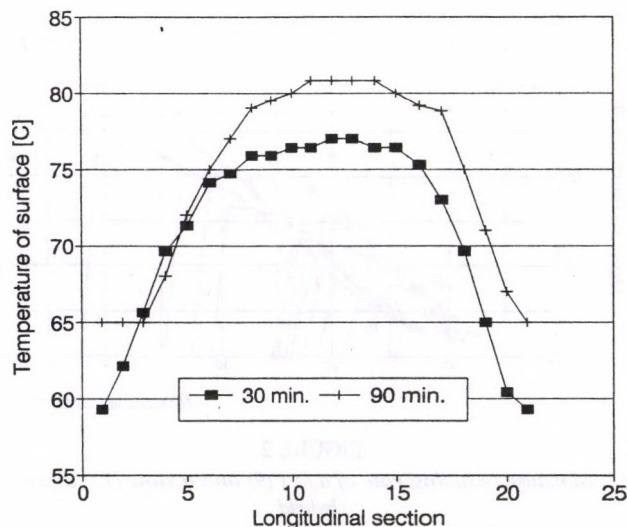

FIGURE 4.

*Longitudinal sections of temperature changing of hybrid No. 9 after 30 and 90 minutes drying*

In Fig.5 the temperature ratio was represented as a function of drying time. On the bases of Fig.1 the conclusion can be drawn that out of the tested hybrids sample 9. dries the most intensively, consequently its temperature is lower than that of the less well drying 2. and 15. samples. It is well proved by the temperature-ratio-changing curves in Fig.5.

## CONCLUSION

Research programme unambiguously proved that changes of state in the grain of maize hybrids during the drying process can be examined by thermovision method, accuracy of differential equations describing heat-, mass-, etc. transports can be controlled.

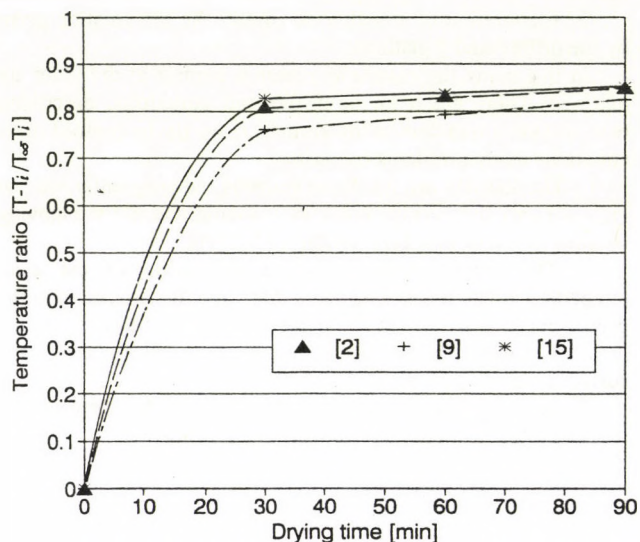

FIGURE 5.

*Temperature ratio of hybrids No. 2., 9. and 15. as a function of drying time*

(Average of 16 grains;  $T$ =temperature of a given surface point (K);  $T_i$ =initial temperature (K);  $T_{\infty}$ =temperature of the drying air (K))

## References

1. Neményi, M., 1983, Improving of energy balance of corn production, with special regard to the factors influencing the heat consumption of grain drying. Theses of Dissertation of PhD degree, Mosonmagyaróvár
2. Neményi, M.; Szodtfridt GY., 1985, Die die Oberfläche der Körner des Hybridmaises ( Zea Mays L. ) beeinflussenden Faktoren. Zeitschrift für Acker und Pflanzenbau, p. 154, 217-221.
3. Neményi, M.; Szabó L., 1987, A new method of determining the pericarp thickness of maize grain, ACTA AGRONOMICA, Volume 36, Issue 3-4.
4. Neményi, M., 1988, Characteristics of maize hybrids dryable with energy saving method, Akadémia Press.
5. Neményi, M., 1990, Drying characteristics of several corn hybrids of different FAO numbers. 4th International Congress on Mechanization and Energy in Agriculture, Adana, Turkey.
6. Neményi, M., 1992, Test of drying characteristics of maize hybrids by thermovision method, Acta Ovariensis, Mosonmagyaróvár, Vol. 34. No.2.

## ENGINEERING AND ENVIRONMENT PROTECTION QUESTIONS OF PLANT ORIGIN ENGINE FUELS

Dr. A. VAS - Dr. V. VARGA  
University of Agricultural Sciences, Gödöllő

The application of vegetable materials such as alcohol vegetable oils for engine fuels are motivated by the replacement of and reduction of the application of fossil energy materials, and more recently by environmental conservation issues. In some developed Western European countries the biofuel production and utilization is a special form of subsidizing agricultural production.

### PLANT OILS AND THEIR PROPERTIES

In this paper engineering and environment protection questions of vegetable oils are discussed. Vegetable oils except castor are applicable to be used in modern diesel engines after some treatment. In the course of our investigation oils originated from rape and sunflower process were tested. The production figures of these two oil plant are compared in Table 1.

Table 1.

Description	Sunflower	Rape
Grain produced (ton/ha)	2.1	1.6
Current producing area (ha)	350 000	60 000
Oil gainable (%)	48	45
(t/ha)	1.0	0.72

In order to utilize vegetable as diesel propellant there were and there are ongoing experiment in almost all European countries including Hungary, too. The consonant opinion was formed that unrefined vegetable hardly oils can be or can not be used as propellants. They can only be utilized at most in low revolution speed, low effective mean pressure, plain diesel engines.

Two experimental directions were followed. Accepting the fuel process technology of esterification method these propellants and there effects were investigated. Examinations were conducted on IFA 4VD 14.5/12-1SRW engine with rape oil methyl aether produced by the Győr Vegetable Oil Factory. In the other part of research parallel to the engine tests mentioned previously a simpler and less dangerous technology near equivalent to esterification has been. The experiments verified that esterificated oils can be well applied in diesel engines without any risk of damage. Measured data of fuel oil and rape methyl aether are summarized in Table 2.

Table 2.

Description	Commercial fuel oil	Rape oil methyl ester
Density (22 °C) (g/cm <sup>3</sup> )	0.833	0.88
Kinematic viscosity (mm <sup>2</sup> /s)	2.72	7.49
Thermal value (MJ/kg)	42.2	38.1
Cetane value	49.0	53.0
Open air flash temperature (°C)	70.0	165.0
Thickening temperature (°C)	0.0	5.0
Congelation point (°C)	-8.0	-3.8
Water content (%)	water free	0.15
Coke content	0.0018	0.0354
Acid number	0.23	0.18

## MIXTURE FORMATION AND COMBUSTION

In diesel engines the mixture should be formed while the crankshaft is turning 50 degrees. The quality of mixture formation has a direct effect on combustion and through this on power, heat state, affectivity and exhaust gas composition of the engine.

The most important factors affecting mixture formation are the injection system, and its adjustment, operation, design of combustion space and properties of fuel. Applying rape oil methyl aether need no change of the injection system. It is practicable however to use pin atomizer in the engine. Adjustment of the injection system should be modified, which should be determined testing bench adjustment according to the engine types. In this one should determine atomizing cone angle, pressure and the preinjection angle data.

The design of combustion chamber is given by the engine types but it is practicable to be taken into account at the time of engine selection. For aetherificated vegetable oils injection piston chamber engines, perhaps pre-combustion chamber engines can be suggested.

Among the properties of fuel density, flash point, viscosity and cetane value are the most important ones effecting mixture formation. As it can be seen from Table 2 the viscosity and flash point are 2.5 times higher. However density and cetane value are 5 % and 8 % higher, respectively. Heat value is lower by 8 %. The differences let us conclude that injection characteristics should be determined with type examinations, case by case.

### TEST BENCH EXAMINATIONS

Testing bench examinations were carried out with IFA 4VD 14.5/12-1SRW engine. In the investigations engine revolution, load and fuel consumption, temperature of entering and exiting water as well as that of exhaust gas were recorded. At some special point the emission characteristics of exhaust gases were also measured.

Considering that the aim of examinations were to compare fuel oil and plant oil aether operation there were quite complete adjustment series were carried out with both fuels. It included atomizing pressure, pre-injection angle and maximum dose of fuel determination. Operational characteristics of engine and the effect of the two fuels were evaluated with the aid of regulator diagram of characteristics. In the interest of data comparativity and objectivity the investigation were carried out with fuel oil first and with vegetable oil methyl aether afterwards. Regulator characteristics are shown in Fig.1 for diesel oil and in the Fig.2 for rape oil methyl aether. Both curves were plotted after adjustment i.e. when optimum values were ensured.

In the case of fuel oil operation there was a significant difference between the tuning data of factory instructions and those determined by us. That is why the tuning parameters are given according to the factory data also to our measuring results for fuel oil and rape methyl aether in Table 3.

In Table 4 the datas belonging to n = 2100 rpm and their alterations (%) are shown.

Table 3.

Description	Fuel oil		Rape oil methyl ester
	factory	measured	
Atomizing pressure (MPa)	18.5	19.0	17.5
Pre-injection angle (Degree)	24.5	29.0	24.0
Fuel consumption per hour (kg/h)	-	19.2	21.5

**Table 4.**

Description	Fuel oil	Rape oil methyl aesther	Alterations (%)
Power (kW)	78.7	72.9	-7.4
Fuel consumption per hour (kg/h)	19.2	21.5	11.2
Specific fuel consumption (g/kWh)	243	295	21.4
Economy affectivity (%)	35.0	32.0	-8.6

From the comparison of test results it can be seen that using rape oil methyl aesther results in power decrease and consumption increase. However the extent of the difference is less in the lower revolution range.

Further important role of the testing bench investigations is the determination of exhaust gas composition. Exhaust gas characteristics of the two types of fuel at  $n = 2100$  rpm are summarized in Table 5. The table also includes the changes in %.

Engines operated with vegetable oils - the so called biodiesels - are considered environment ally friendly or environmental ones. It is supported by the data of Table 5 and by the fact that the carbon dioxide resulting naturally from combustion will not increase the CO<sub>2</sub> load on environment. The measurements were conducted with INFRALYTE 4000 and AVL 437 type instruments.

Further advantage of biodiesels is that the particle emission is only the half also the hydrocarbon content is only the two third of the relevant values of the fuel operated engines. It should be highlighted that there is no sulphide in the exhaust gas of biodiesel.

The increase of carbon monoxide and especially the nitrogen oxide content raises the question of catalyzer application.

**Table 5.**

Description	Fuel oil	Rape oil methyl ester	Alterations (%)
Carbon monoxide (vol %)	0.19	0.21	9.1
Hydrocarbons (ppm)	21.8	16	-36.4
Nitrogen oxides (ppm)	1057	1150	8.1
Smoke density (smoke t) (mg/m <sup>3</sup> )	47.0	31.0	-51.6
Smoke light absorbing capacity (1/m)	-	0.35	-

As an effect of aestherificated vegetable oils application the change of lubricant oil viscosity and other oil properties is unfavourable. That is why the oil replacement cycles should be revised by means of measurements. According to some foreign sources oil replacement cycles should be decrease by 50 %.

**SUMMARY**

Vegetable oils are applicable to operate diesel engines after preparation without any special modifications of engine. The decrease in power can be mainly due to the difference in the thermal value and it is proportional to that (9 %), also the increase of consumption is even higher. The heat state of engine expose significant change.

The exhaust gas composition - due mainly to the particle emission - can be judged quite favourable. On the basis of these one can state that there is no technical drawback of widespread application of vegetable oils.

However wide application of vegetable oils as engine fuels can not be expected in the near future. The reasons are economical ones. The price of them is high compared to the fossil oil product prices at so their production cost of them is nearly the same as the fuel oil commercial price including taxes.

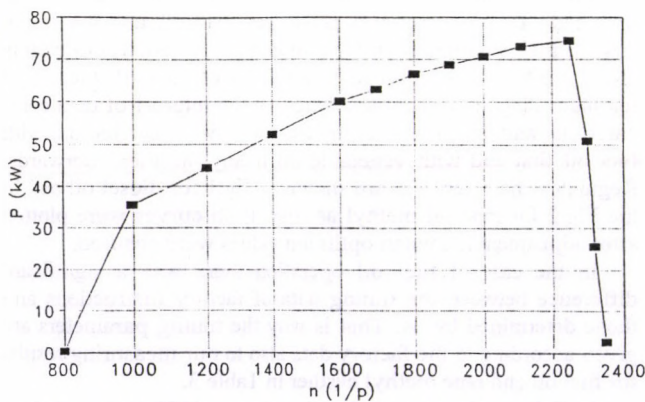

$p(\text{open}) = 175 \text{ bar}$   $\Theta = 24 \text{ degrees}$

**FIGURE 1.**

*IFA regulator characteristic curve with rape oil methyl ester operation*

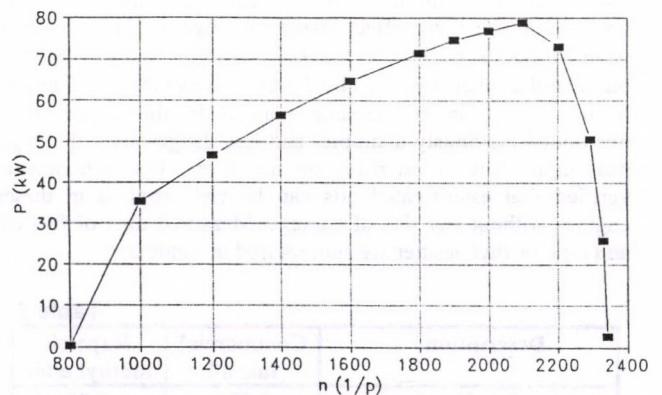

$p(\text{open}) = 190 \text{ bar}$   $\Theta = 28 \text{ degrees}$

**FIGURE 2.**

*IFA regulator characteristic curve with fuel oil operation*

## MATHEMATICAL MODEL OF MASS REDUCING OF TILLAGE MACHINES

Dr. I. PÁLINKÁS  
University of Agricultural Sciences, Gödöllő

The unreasonably higher weight of tillage machines increase the production cost and the market competitiveness. The user complains of high purchase price, the higher energy consumption and the increased soil compaction. So it is practicable if the machine mass reducing is a development aim.

### USEFUL MASS OF CULTIVATION MACHINES ( $m_h$ ) AND THE TERM OF MASS UTILIZATION ( $t$ )

To the calculations aiding cultivation machine development the useful mass ( $m_h$ ), the specific useful mass ( $m_{fh}$ ) and the mass utilization ( $t$ ) terms were introduced.

#### Useful mass of cultivation machines ( $m_h$ )

Useful mass ( $m_h$ ) is part of the machine mass ( $m$ ) which serves the weight to keep the cultivation elements in the prescribed depth. Similarly to the creation of the specific mass if the specific useful mass ( $m_{fh}$ ) is related to a functionally characteristic parameter above all to the working width at cultivation machines a specific useful mass ( $m_{fh}$ ) of a given machine type is determined. In the case of tillage machines the general form of useful mass is

$$m_h = C k h B \text{ (kg)}$$

$$m_{fh} = C k h \text{ (kg/m)}$$

where

- h - is the cultivation depth (m)
- B - is the working width (m)
- k - specific traction resistance ( $N/m^2$ )
- C - factor depending on machine character, design and operation mode

In the case of

plough:  $C_p = g^{-1} \operatorname{tg} \psi \text{ (s}^2/\text{m)}$

disk:  $C_t = g^{-1} \sin \varphi \operatorname{tg} \psi^* [\sin(\alpha + \varphi)]^{-1} \text{ (s}^2/\text{m)}$

harrow:  $C_h = g^{-1} \{2 l^* L^{*-1} + [\mu \operatorname{tg}(\alpha^* + \gamma)] - 1\} \cdot [\mu + \operatorname{tg}(\alpha^* + \gamma)]^{-1} - h L^{*-1} \text{ (s}^2/\text{m)}$

where

- g - acceleration of gravity ( $m/s^2$ )
- $\psi$  - angle depending on share seediness ( $^\circ$ )
- $\alpha$  - disk element traction angle ( $^\circ$ )
- $\varphi$  - angle formed by the rotation axis of disk and soil reaction component  $F_{xy}$  ( $^\circ$ )
- $\psi^*$  - angle formed by the resultant of soil reaction forces acting on disk edge and the motion direction ( $^\circ$ )
- $\alpha^*$  - tine inclination angle to motion direction ( $^\circ$ )
- $\gamma$  - cone half angle of tine ( $^\circ$ )
- $l^*$  - length of tine (m)
- $L^*$  - harrow member length (m)
- $\mu$  - friction coefficient between soil and tine

#### Mass utilization factor ( $t$ )

Mass utilization factor is given by expression

$$t = 10^2 m_h m^{-1} \text{ (%)}$$

which expresses how large percent of the cultivation machine mass ( $m$ ) is necessary to perform the task. By means of this parameter not only the same but the different purpose machines also can be compared and the measure of their overweight is determinable, too.

### INTERACTION OF THE ELEMENTS OF IMPLEMENT - POWER MACHINE - SOIL SYSTEM

In implement - power machine - soil system the changing mass of implement ( $dm$ ) influences the power machine, and the soil also as the other two elements of the system.

Concerning this a double calculation method was elaborated which is applicable to determine concrete and percentage values of examined parameters to both  $dm$  and  $dm_f$  absolute and relative values ( $dm'$ ;  $dm_f'$ ).

As functions of mass reduction ( $dm$ ) expressions determining the absolute and relative changing of aggregate traction force ( $dF_{fv}$ ;  $dF_{fv}'$ ), the power machine ( $dp_1$ ;  $dp_1'$ ) and the implement ( $dp_2$ ;  $dp_2'$ ) soil pressure.

#### Traction force in the function of mass reduction

$$F_v = b_0 m \text{ (N)}$$

$$dF_v = b_1 m_f + b_2 dm \text{ (N/m)}$$

$$dF_v' = b_3 + b_4 dm' \text{ (%)}$$

where

$b_0$ ;  $b_1$ ;  $b_2$ ;  $b_3$  and  $b_4$  are multipliers depending on the type design and operation mode of cultivation machine and aggregate and the quality of power machine - implement connection

#### Pressure change produced on the soil by the power machine wheels

$$p_1 = b_0 G_{adh}^{1/3} \text{ (Pa)}$$

$$dp_1 = b_0 G_{adh}^{1/3} [1 - (1 - \frac{dG_{adh}}{G_{adh}})^{1/3}] \text{ (Pa)}$$

$$dp_1' = 10^2 [1 - (1 - 10^{-2} dG_{adh}')^{1/3}] \text{ (%)}$$

where

- $G_{adh}$  - is the adhesion weight of power machine at the rear wheel (N)
- $b_0$  - is a multiplier depending on the number and size of +tires, the inner pressure and the soil

#### Pressure produced on the soil by the cultivation machine wheels

$$p_2 = b_0 m^{1/3} \text{ (Pa)}$$

$$dp_2 = b_0 G_{adh}^{1/3} [1 - (1 - \frac{dm}{(1 - 10^{-2} t) m})^{1/3}] \text{ (Pa)}$$

$$dp_2' = 10^2 [1 - (1 - \frac{dm'}{10^{-2} t})^{1/3}] \text{ (%)}$$

where

- $b_0$  - is a multiplier depending on the total utilization factor of cultivation machine, its tyre size, inner pressure, soil and aggregate sizes.

## DETERMINATION OF OBTAINABLE MASS REDUCTION

For the preliminary determination of results of the mass reduction techniques in the course of development a double calculation method based on stress analysis was elaborated. For the calculations terms of profile factor ( $Z_{i;j}$ ) and material factor ( $H_{i;p}$ ) were introduced.

The profile factor is a characteristic parameter depending on the shape and surface of the section. It is applicable to classify sections according to the material saving. Lower mass part of same strength value can be made from profiles of higher shape factor.

Material factor is characteristic to the examined material depending on the physical and mechanical properties of part. It is applicable to classify materials according to the material saving.

Lower mass part of same strength value can be made from materials of higher material factor.

	Profile factor	Material factor
Tension:		$H_{0;p} = 10 R_{mp} \varsigma_p^{-1}$
Bending:	$Z_{1;j} = K_{1;j}^{2/3} A_j^{-1}$	$H_{1;p} = 10^2 R_{mp}^{2/3} \varsigma_p^{-1}$
Torsion:	$Z_{3;j} = K_{3;j}^{2/3} A_j^{-1}$	$H_{3;p} = 10^2 \tau_p^{2/3} \varsigma_p^{-1}$

where

i	-	is mark of load
j	-	is mark of section before development
j+k	-	is mark for section after development
p	-	is mark of material quality before development
p+1	-	is mark of material quality after development
K	-	cross section factor
A	-	cross section area
$R_{mp}$	-	ultimate stress
$\varsigma_p$	-	density
$\tau$	-	shear strength

The function of obtainable mass reduction was derived both for simple and complex stress states. The method is suitable to derive absolute and relative values of mass reduction obtainable by means of changing the cross section shape and/or material quality of part.

Tension - bending

$$dm' = 10^2 \left\{ 1 - \frac{H_{0;p}}{H_{0;p+1}} \left[ \frac{1}{1 + e_1 A_j^{-1/2} Z_{1;j}^{-3/2}} + \frac{e_1 Z_{1;j+k}^{-1} (A_j Z_{1;j} H_{1;p} \varsigma_p)^{-1/2} (H_{1;p+1} \varsigma_{p+1})^{1/2}}{1 + e_1 A_j^{-1/2} Z_{1;j}^{-3/2}} \right] \right\} (\%)$$

Tension - twist

$$dm' = 10^2 \left\{ 1 - \frac{H_{0;p}}{H_{0;p+1}} \left[ \frac{1}{1 + e_2^2 A_j^{-1} Z_{1;j}^{-3}} + \frac{4e_2^2 (A_j Z_{3;j} \varsigma_p H_{3;p+1})^{-1} Z_{3;j+k}^{-2} (H_{3;p} \varsigma_{p+1})^{1/2}}{1 + e_2^2 A_j^{-1} Z_{1;j}^{-3}} \right] \right\} (\%)$$

Bending - twist

$$dm' = 10^2 \left[ 1 - \frac{H_{1;p} Z_{3;j}}{H_{1;p+1} Z_{3;j+k}} \cdot \left( \frac{4 + e_3^2 Z_{3;j+k}^3 Z_{1;j+k}^{-3}}{4 + e_3^2 Z_{1;j}^{-3} Z_{3;j}^3} \right)^{1/3} \right] (\%)$$

where

- $e_1$  - is load ratio of bending moment and tension force
- $e_2$  - is load ratio of torsion moment and tension force
- $e_3$  - is load ratio of bending and twisting moments

## EFFECT OF THE ACHIEVED MASS REDUCTION

### Effect of the mass reduction on energy consumption

Operational expenses of tillage machines such as labour, energy, maintenance, reparation and other cost have often further additional cost effects.

Among these factors the variation of energy consumption which is the basis of the energy cost is expressed as follows

$$dE' = (1 + m_e m_1^{-1} + a t)^{-1} dm' (\%)$$

where

- $dE'$  - is the change in energy need
- $m_e$  - is the mass of power machine (kg)
- $m_1$  - is the mass of implement before reduction (kg)
- $a$  - is a factor depending on the character of soil cultivation
- $t$  - is the mass utilization factor (%)

### Effect of mass reduction on fabrication cost

Fabrication cost is complex similarly to operation cost. A part of cost is characteristic not to the product but rather to the factory (e.g. overhead cost). Among fabrication costs the so called direct material cost can be considered characteristic parameter to a given machine and can be separated from the organization and technology level of factory.

$$dQ' = dq' + (1 - 10^{-2} dq') dm' (\%)$$

where

- $dQ'$  - is the change in material cost of part (%)
- $dq'$  - is the change of specific material cost (%)

Making use of the presented most important relationships one can decide the necessity of mass reduction, the measure of obtainable mass reduction taking into account of possibilities, the effect on the power machine and soil and to the energy consumption and fabrication cost.

### References

1. Bánházi, J.; Koltay, J.; Soós, P., Theoretical principles of the operation of arable land implements, Mezőgazdasági Kiadó, Budapest, p. 523. (in Hungarian)
2. Borsa, B., 1988, Prüfung der Zug kraftverteilung beim Pflügen uuf Normalitat, Grundl. Landtechnik. Bd. 38. Nr.5.
3. Getzlaff, G., Messung der Kraftkomponenten an einem Pflugkörper, Grundl. Landtechnik. H. 1(1951)5. 16/24.

## OPERATION EXPERIENCES OF DAIRY COW PLANTS SUPPLIED WITH COMPUTER PRODUCTION MANAGEMENT SYSTEM

Dr. A. ERÉNYI

University of Agricultural Sciences,  
Agricultural Engineering College, Mezőtúr

In our dairy farms computerized production management systems are installed in increasing number in the past years. It is their characteristics that they are adapted versions of systems developed in different countries, e.g. Gascoigne-Melotte, Alfa-Laval, Nedap-Poiesz, Fullwood, Afimilk systems. There is also a home developed system created in the National Institute of Agricultural Engineering. The extension degree is different. On some farms with the aid of computer central unit and manual data input data storage, handling, registration and calculation task are carried out while on other farms complex production management systems expanded with subsystems can be found.

In the case of milking house subsystems besides the identification of animals the milk output is automatically recorded. Additionally other significant data of production can be also recorded by using automatic sensors.

Fodder automatic feeding can make the production management complete. The basis is also the individual identification of animals and the animals kept free can get the fodder determined in advance according to the production of the animal.

In dairy farms operating with computerized production management several advantages exist from both breeding and animal health and rentability aspects, such as

- the time between two calvings can be reduced,
- the number of inseminations and the work with them can be reduced,
- illness of animals can be recognized in time,
- specific fodder consumption can be reduced,
- information is available promptly for the farm managers, etc.

The advantages of farm management system can be exploited completely if the relevant equipments operate reliably. That is why the aim of this work is to study the typical systems and the units playing key roles in operation.

Laboratory and in plant investigations were carried out and foreign as well as home experiences were used. In the laboratory examinations the study model installed in the laboratory of the Department of Structure and Operation of Husbandry Machines of the College was used. The study model was built by Boscoop based on Gascoigne-Melotte units and it represents a fish-bone arranged, bottom milkline, individual milk meter milking room system. The computerized management system is Nedap-Poiesz VC-3 type with automatic feeder.

The system starting from a main menu is applicable to register the farm stock, group of animals, individual animals to measure milk volume, body weight and temperature as well as to feed the fodder individually. Additionally a variety of control, review and warning lists can be printed, too. As a

matter of fact similar services are supplied by the majority of different development farm management systems.

At the operation of plant management systems in technical viewpoint one of the most important tasks is the identification of animals and the reliable operation of the sensor and control units. In the case of widely used number code individual identifying responders and transponders perfect 100 % recognition can hardly be obtained. Based on plant examinations the most frequent faults are loosing, late supplying, turning off, misplacing and defects of transducers. In the case of milking room identifying the accuracy can be improved by using portal identifiers, frame antennas, but the attention of milkmen is necessary if in case of lacking transponder the recognition of an animal has not happened. This can result in a shift of animal identification of the same row of stands and the order should be corrected manually. Already implantable transducers are commercially brought in and the mentioned troubles can be eliminated and in the case of suitable operation reliability they are proper for perfect identification.

Milk quantity meters are most important units of milkhous subsystem. Their job is determining milked quantity, displaying and short time storing the value such way that the data could be transferred to the central computer. Acceptable precision is a requirement to the milk meters even the ratio of air and milk is changing in the flow. From the examination data of different system and type milk quantity meters it is concluded that their precision can be kept within 3 % error limits. The measuring error value of milk meters is lower with the specialized computerized production management systems than that of systems where the electric sensors, displays and control units were installed additionally.

Individual fodder to animals according to the milk production is supplied in cow-house or open air feeders. It is a requirement to screw or cell type volume or mass measuring based feeders to supply the fodder with the necessary precision and corresponding to the eating rate. The accuracy of apportionment is the best with mass measuring device. Using operating device to prevent vaulting in the prestorage and feeder tanks is significant. The vaulting prevention device of the National Institute of Agricultural Engineering is a good example of its. In the operation of system the number of animals per feedtank is an important question because consuming the daily quantity of fodder by each animal can be warranted only by the appropriate selection of this. In free keeping farms 20-30 cows can be considered per feedtanks, but in the case of high production level groups the practicable number is 15-20 animal per feeder.

A computerized plant management system can be extended to deal with not only animal identification, stock registration, milk quantity measuring and automatic fodder apportionment, but with automatic registration of further data. The facility is given in different extent with the different systems. Such way e.g. determining the conductivity of milk, measuring the body weight and temperature, monitoring the animal activity would give more information to the farm staff.

There are further possibilities to utilize the existing computer capacity of plants if e.g. operational data are collected from the installed machine apparatuses by using transducers or sensors. That is the way making the animal - man - technology connections complete.

## ANALYSIS MEASURING ERRORS OF MEASURING CIRCUIT BUILT WITH THERMOCOUPLE

Dr. GY. VINCZE - I. SERES  
University of Agricultural Science, Gödöllő

### THEORY OF MEASURING WITHOUT STABILIZED REFERENCE POINT

The origin of electric voltage of thermocouple when different metals are touching is the temperature dependence of the arising Galvani voltage. As the half spin electrons follow the Fermi-Dirac statistics the chemical potential of electron gas (WF) can be determined by integration from the distribution function. However the Galvani voltage is given by expression

$$U_g = (W_{Fa} - W_{Fb}) / e$$

where the indexes a and b refer to the two metals and e is the elementary charge.

If the cold point temperature of a thermocouple is  $T_0$  and the measuring point temperature is  $T$ , the thermo-voltage has the following properties:

$$(a) \text{ antisymmetry: } U(T, T_0) = -U(T_0, T)$$

$$(b) \text{ absorption: } U(T, T_0) = U(T, T^*) + U(T^*, T_0)$$

the latter is a consequence of Volta's law.

It can be proved that if this properties hold, the thermo-voltage can be written in the form of

$$U(T, T_0) = \sum_{i=1}^n \alpha_i (T^{2i} - T_0^{2i})$$

where the  $\alpha_i$  coefficients can be determined from the zero point Fermi energy. [1]

However, these relationships hold only for Seebeck effect but (a) and (b) properties do not hold for the connecting phenomena arising additionally and consequently they cause an error in the measurement. This error is discussed by means of non-equilibrium thermodynamic.

### NON-EQUILIBRIUM THERMODYNAMIC THEORY OF THERMOELECTRICITY

Let us apply the Onsager's law of non-equilibrium thermodynamic to the thermocouple corresponding to the Fig.1. Based on [2] the electric current density ( $J_e$ ) and heat current density ( $J_q$ ) vectors can be expressed by

$$J_e = \delta [(\nabla\mu/e) - (\varepsilon \nabla T)] \quad (1)$$

$$J_q = T \delta \varepsilon \nabla\mu/e - (T \delta \varepsilon^2 + k) \nabla T \quad (2)$$

where e is the elementary charge, T is the absolute temperature,  $\delta$  is the wire electric conductivity, k is the heat conduction coefficient,  $\varepsilon$  is the absolute Seebeck coefficient.  $\mu$  electrochemical potential is composed from an electric and a chemical potential

$$\mu = \mu^* - e U \quad (3)$$

where  $\mu^*$  is the chemical potential of electrons and U is the macroscopic electric potential.

With  $\mu^*$  the word "chemical" indicates that the resultant force acting on electrons depends not only on the gradient of U,

but on the heat and electron concentration function gradients also. Here the chemical potential is function of local temperature and material composition only [2].

$\mu^*$  and U can not be determined separately making use of nonequilibrium thermodynamics only their combination in (3) presents itself in equations (1) and (2).

The role of  $\varepsilon$  Seebeck multiplier can be demonstrated by using  $J_e$  as a variable instead of  $\nabla\mu$  in equation (2). In this case

$$J_q = T \varepsilon J_e - k \nabla T \quad (4)$$

i.e.  $\varepsilon$  expresses the thermoelectric connection, since in the case of  $\varepsilon = 0$   $J_q$  and  $J_e$  become independent on each other, (1) and (2) equations are simplified to equations of electric conduction (1) and heat conduction (2).

For thermocouple temperature sensor the Fig.1 arrangement is usually used. As the wires of voltage meter are of same composition and temperature, so the resultant chemical potential is zero

$$\mu^*(s_5) - \mu^*(s_0) = 0$$

between  $s_0$  and  $s_5$  and by using (3) the voltage measured by voltage meter will be

$$U(s_5) - U(s_0) = -[\mu(s_5) - \mu(s_0)] / e \quad (5)$$

$\mu$  function can be derived in the circuit by creating  $J_e = 0$  current density and by integrating making use of (1).

$$\mu(s) = \mu(s_0) + e \int_0^s \varepsilon(s, T) (dT/ds) ds \quad (6)$$

so electric voltage will develop only on the parts where the heat gradient is not zero.

With the application of formula (5) the expression

$$-\Delta U = \nabla\mu/e = \int_0^{s_1} \varepsilon_a (dT/ds) ds + \int_{s_1}^{s_2} \varepsilon(s, T) (dT/ds) ds + \int_{s_2}^{s_3} \varepsilon_b (dT/ds) ds + \int_{s_3}^{s_4} \varepsilon(s, T) (dT/ds) ds + \int_{s_4}^{s_5} \varepsilon_a (dT/ds) ds \quad (7)$$

can be written. In this  $\varepsilon_a$  and  $\varepsilon_b$  are the absolute Seebeck coefficients of a and b marked wires, in the contact section of the two wires  $\varepsilon$  is an unknown function of the place and temperature. If the temperature gradient is zero in the contact section (the significance of this will be presented in the section 3) the 2nd and 4th parts disappear, changing from the integration along wire length to time integration the equation will be

$$U(s_5) - U(s_0) = \int_{T_1}^{T_2} [\varepsilon_a(T) - \varepsilon_b(T)] dT = \int_{T_1}^{T_2} \varepsilon_{ab} dT \quad (8)$$

it is the usual form of Seebeck tension,  $\varepsilon_{ab}$  is the relative Seebeck coefficient.

#### Let us deal with the reversible heat now

Total energy current in a conductor under electric current is given by

$$J_u = J_q - (\mu J_e/e) \quad (9)$$

where the first term is the heat current and the second term is the potential energy current. The inner energy developing in the unit volume of a wire during unit time is given by the divergence of  $J_u$ .

As the wire cross section area is small the problem is one dimensional. Making use of (1) and (4)

$$\sigma_u = \partial J u / \partial s = - (J e^2 / \delta) + (J e T d \epsilon / d s) - [d / d s (k d T / d s)] \quad (10)$$

is got, where the first member describe the Joule heat and the second one is for the heat conduction of the electricity free wire. The middle term expresses thermo-electric heat which is the source of Peltier and Thomson heat. Since the expression is a first degree function of  $J e$  i.e. it is generated or absorbed according to the sign of  $J e$ , so this is reversible heat.

In the junction for the  $\epsilon(s, T)$  function

$$d \epsilon / d s = \partial \epsilon / \partial s + (\partial \epsilon / \partial T) (d T / d s) \quad (11)$$

If  $d T / d s = 0$  along the junction according to those presented in connection with equation (8) then there the middle term of (10) gives the followings for the heat generated or absorbed on the unit surface during unit time

$$\sigma_u = \int_{T_1}^{T_2} J e T (\partial \epsilon / \partial s) ds = J e T_1 [\epsilon_b(T_1) - \epsilon_a(T_1)] \quad (12)$$

which is the Peltier heat and  $T_1 [\epsilon_b(T_1) - \epsilon_a(T_1)]$  is the Peltier coefficient of fitting.

Far from the contact places the material is homogenous and there the variation of  $\epsilon$  depends only on the temperature gradient. In this case the thermoelectric heat for unit volume from the middle member of (10) is

$$\sigma_u = J e T (d \epsilon_a(T) / d T) d T / d s \quad (13)$$

called Thomson heat and  $T(d \epsilon_a / d T)$  is the Thomson coefficient.

## SOURCES OF ERRORS

Theory of the measurement is based on laws discussed in section 1. For this it is necessary to express the thermovoltage as the integral of difference of two Seebeck functions which depends only on the temperature.

According to equation (7) this always holds if the connection on the contact surface is physical. In the case of welded or soldered connection a transitional zone is formed which will not give additional thermovoltage only if there is no temperature gradient. In measuring technology this can be solved with perfect heat contact.

The chemical potential of the thermocouple components is also heat depending which results in additional error. The error can be eliminated by oppositely joined thermocouple (Fig.1) and keeping  $s_5$  and  $s_6$  spots on same temperature.

The additional two sources of error are the Peltier and Thomson heat resulted by thermodynamic cross-effects. The first is produced at the place of connection in the case of zero temperature gradient and the other under temperature gradient. To verify this the source term of internal energy was determined according to equation (10). The first and second member of (10) is interested because they can change the temperature of contact points.

The first term can be neglected in the case of welded or soldered connections, however the term

$$J e T \partial \epsilon / \partial s \quad (14)$$

arises from which the heat generated in the transition zone can be calculated by integration in accordance with the equation (12). This term can be reduced by decreasing  $J e$ .

At twisted connections the resultant of parts originated from the first and second members will arise

$$- J e^2 / \delta + [J e T \partial \epsilon / \partial T d T / d s] \quad (15)$$

Similarly to the previous case both term can be reduced arbitrarily by reducing  $J e$  value.

The next error source is the effect of magnetic field. It is known from Onsager's theory [2] that the coefficients material equation depend on the magnetic induction  $B$ . This results in error at low temperature. Let us examine that most practicable case when the measuring point is in strong magnetic field and the cold junction and the voltage meter in negligible magnetic field (Fig.2).

In order to examine the phenomenon let us integrate equation (5) and use that  $d T / d s = 0$  in the contact zone,  $T(s_3) = T(s_6)$  and between  $s_3$  and  $s_4$  function  $B(s)$  is mirrored image of the function part between  $s_5$  and  $s_6$  (Fig.3). In this case we have

$$\begin{aligned} \Delta U &= \int_{T(s_3)}^{T_1} [\epsilon_a(T) - \epsilon_b(T)] dT + = \\ &= \int_{s_3}^{s_4} [\epsilon_a(T, H) - \epsilon_b(T, H)] (dT / ds) ds \end{aligned} \quad (16)$$

One can see that the value of expression determined by (16) depends on the relation between temperature gradient and magnetic field in space and is different for each experimental setup. If however, the domains of temperature gradient and magnetic field do not coincide each other, like e.g. in the case of  $T^*(s)$  temperature distribution of figure 3, then (16) can be written in the form of

$$\Delta U = \int_{T_1}^{T_2} [\epsilon_a(T) - \epsilon_b(T)] dT \quad (17)$$

so that in this case temperature measurement is not perturbed by magnetic field. (As it has been verified experimentally). This fact promote the opinion that thermovoltage can originate only from section exposed to temperature gradient.

Magnetic field could be considered as if it changed the material composition in the high intensity domain resulting in large extension contact zone.

## References

1. Seres, I., 1992, Temperature measurement with thermocouple having no stabilized cold point, Gödöllő (in Hungarian).
2. Callen, H.B., 1966, Thermodynamics, Wilev, New York, USA.
3. Walstrom, P.L., 1988, Spatial dependence of thermoelectric voltages and reversible heats, American Journal of Physics.

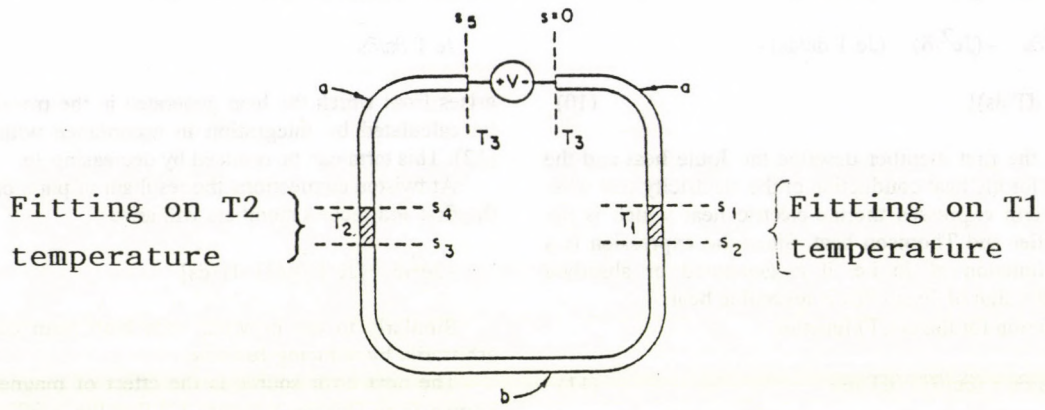

FIGURE 1.

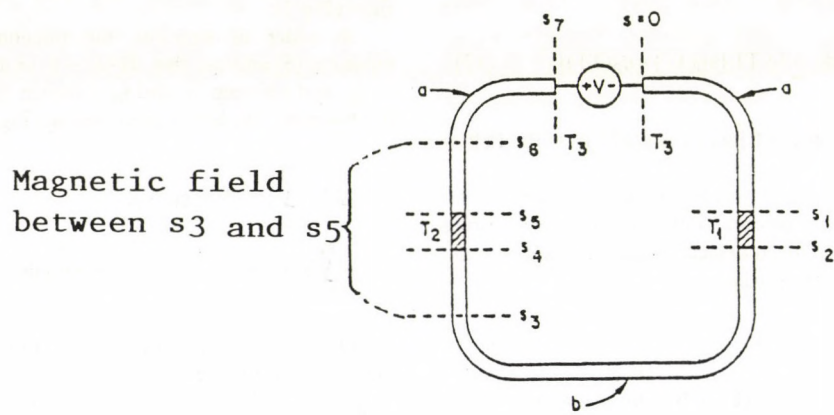

FIGURE 2.

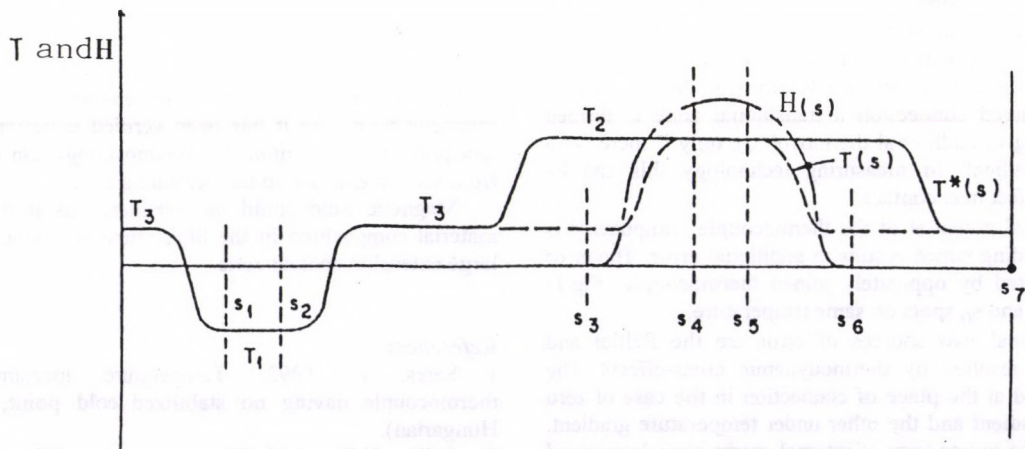

FIGURE 3.

## ROUTE PLANNING ON TRANSPORT NETWORK

Dr. J. BENKŐ

University of Agricultural Sciences, Gödöllő

Logistical costs are key factors among the operational costs. According to some estimations they can reach as much as 20-25 % of the relevant turnover considering the company competitiveness that can be essential. This fact was already discovered in the developed countries in the beginning of seventies and they made great efforts to reduce logistics costs. In the previous years the production and marketing were in focus and physical distribution was not paid attention. P. Converse, a noted marketing professor, said that business had been paying a great deal more attention to buying and selling than to physical distribution. The new concept necessarily resulted some activities previously considered solely as responsibility of production or marketing have been regrouped. Logistics occupied a strategic organizational position between production and marketing. That means activities previously ordered under production and marketing management have been regrouped and logistics management have become responsible for some of them. According to the most recent concept integrated logistics includes material management, inventory maintenance and physical distribution, as well as supporting activities like transport, warehousing, material handling. Of course, independence of logistics is not self-contained it means more effectiveness services for production on input side and for customers on output side and it provides decreasing costs. Close co-operation with production and marketing and establishing information channels are the preconditions of its. This is usually realized through interface activities which must be jointly managed on two or more area by top management. For example between logistics and production interface activities are product scheduling, purchasing or between logistics and marketing customer service pricing etc.

Logistics management is a job that is carried out on three levels (strategic, tactical and operational). In strategic level the logistics system itself is formed i.e. the strategic planning means establishing and realizing long term, overall, comprehensive conceptions of the system. Task of tactical planning is the optimal utilization of available resources. Finally operation planning means management and solution of daily jobs. The extension of such tasks are extremely wide including the all logistic services to meet the demands of different parts of production process relating to daily problems of material management, inventory and physical distribution. The condition of the successful operations of logistics system to create harmony i.e. to use most favourable solutions in every level. In this context operational planning needs as much care as long term strategy.

Today no one argues that transport is the most costly and important operation of logistics activities. Traffic manager who schedules vehicles faces to simple everyday problem of route planning, assignment of vehicles, determination of shortest path etc. Among them the shortest path is most frequent problem which means nothing else but seeking for optimal path of a vehicle on given traffic network. The optimal path can be the shortest route, the shortest travel time or their combination. In the case of a few combination decision can be made simple hand calculation or without it but in more complex cases and especially in the case of quick decision need using computer must be used for calculation especially if quick decision is required.

Graphs are usually used to represent networks (roads, circuits etc.). A variety of combinatorial problems can be solved making use of theory of graphs. Among others such a problem is finding the shortest path between the nodes of graphs. The problem is usually that a point called source is given on the

graph and one should find all shortest paths from source to all other nodes. But it happens as in our case that we want to know the shortest path only between two given nodes. Unfortunately, to solve this last problem there is no more effective algorithm than the so called one source algorithms. Therefore this paper presents an one source algorithm.

Route network is symbolized by  $G = (P, C)$  directed graph which consists of a set of nodes (towns) and a set of arcs (routes). Elements of set of nodes are represented by  $P_i$ , ( $i = 1, 2, \dots, n$ ) and the elements of  $C$  are the elements of  $c_{ij}$  matrix, ( $i, j = 1, 2, \dots, n$ ).  $c_{ij}$  is the distance between nodes  $P_i$  and  $P_j$ . If there is no arc between two nodes  $c_{ij} = M$ , where  $M$  is a large number.

Let  $a_{ij}^{(k)}$  be the shortest path from  $P_i$  node to  $P_j$  node containing less than  $k$  arcs and the path contains any node only once.

$k = 1, 2, \dots, n-1$  is the number of the phases. If there is no path from  $i$  to  $j$ , then

$$a_{ij}^{(k)} = M,$$

where  $M$  is a large number.

If  $k = 1$  and  $i = s$  is the freely selectable origin, the direct paths from  $s$  to  $j$ :

$$a_{sj}^{(1)} = c_{sj}.$$

These paths can be shortened to get together the paths from  $s$  to  $i$  containing  $k$  arcs with  $c_{ij}$  arcs, and the set of these select the shortest, this way

$$a_{sj}^{(k+1)} = \min \{a_{sj}^{(k)} + c_{ij}\},$$

where  $i = j = 1, 2, \dots, (s-1), (s+1), \dots, n$ , and  $k = 1, 2, \dots, n-1$

if

$$a_{sj}^{(k+1)} < a_{sj}^{(k)},$$

otherwise

$$a_{sj}^{(k+1)} = a_{sj}^{(k)}.$$

In the case of  $s = j$  closing of the series of arcs are prevented by

$$c_{sj} = M.$$

Using the above formula recursively after maximum  $k = n-1$  iteration shortest paths from  $s$  to  $j = 1, 2, \dots, (s-1), (s+1), \dots, n$  are obtained.

The algorithm can be applied very simple to find a shortest path on network of Hungarian roads. Let the  $P$  nodes of  $G$  graph labelled by the name of the settlements and the arcs are the connecting roads. However, not only the distances but directions and quality can also be attached to the set of  $C$ . The latter parameter indicates the allowed or reachable average speed on the road. Such a way the database makes possible finding the quickest path beyond the shortest path. The computer program for utilization can be made applicable to find shortest path containing more destinations to display the detailed route plan and to change simple the criteria of optimization (time or distance).

### References:

1. Aho, A.V.; Hopcroft, J.E.; Ullman, J.D., 1982, Planning and Analysis of Computer Algorithms, Műszaki Könyvkiadó, Budapest. (in Hungarian)
2. Ballou, R.H., 1987, Basic Business Logistics, Transportation, Materials Management, Physical Distribution, Prentice-Hall International Inc.

## A SYNTHESIS OF THE INTER-RELATIONS ANIMAL HOUSE, ENVIRONMENT, RENTABILITY, HUMAN AND ANIMAL WELFARE

Dr. A. MATON  
RvL, Merelbeke, Belgium

The environmental incidences of animal husbandry are important but nevertheless only one aspect of this economic activity. They must therefore be put in a larger context. Considering all the above mentioned factors we come to the following conclusions.

**For dairy cattle:** the cattle keeper has the choice between different cow house types.

The strawed stanchion barn demands, independent from the number of cows, the lowest investment, leads to the lowest ammonia emission, produces economically valuable solid manure. Its labour demand (Fig.1) is however very high (min. 55 hr/cows/year - 60 cows), its annual costs, from 35 cows on, also highest of all cow house types (Fig.2). Milking must still be done in the cow house which is not ideal from the hygienic point of view and is fatiguing. Although straw forms a sweet layer in the stall, that traumas are rather frequent and the animals are often rather dirty. One cannot set the clock back and, although this type of cow house is still well spread in Europe, there will be little place for it on a large and even hot on the medium-sized dairy farms of the future.

The strawless stanchion barn with grids has "grosso modo" the same advantages and disadvantages, be it for both, to a lesser extent, except for manure and animal welfare. This cow house produces the less appreciated liquid manure and teat traumas are frequent. Also this type of cow house doesn't seem to have a bright future.

In the strawless cubicle house for cows labour demand (Fig.1) is low (about 40 hr/cow/year - 60 cows), the annual costs (Fig.2) are lower than those of stanchion barns from 40 cows on and the difference becomes bigger for increasing number of cows. From 80 cows on the investment is comparable with the one needed for a stanchion barn with grids; equipped with slatted floor its asks always, independent of the number of cows, for a higher investment than with concret the passage ways between the cubicle rows. Milking is done in a separate parlour (hygienic, comfortable working conditions). The animals are mostly clean and healthy, except for what concerns claw lesions, which, in particular on full concrete floorings, can be rather severe (Maton ea., 1985).

Ammonia emission, although higher than from stanchion barns, is nevertheless limited. Efforts must be done to develop a less expensive flushing system with liquid separated from the liquid manure. This separation leads furthermore to a (composted) solid fraction, which is appreciated. As ammonia emission is limited, this separation should, for economic reasons, only be done in areas with N and P surpluses. Considering all factors, the cubicle house is for dairy farms of

medium and large size, which will form the bulk in future, the most indicated type of cow house.

The strawed loose house is another possibility for housing dairy cows and is obliging for the highly priced double muscled beef cattle. It leads to some ammonia emission because of the permanent presence in it of straw manure, which is on the other hand valuable. Ordinary beef cattle is often housed on fully slatted floors, the most economic solution, producing a tolerable ammonia emission but lots of slurry.

**For pig housing** also it is interesting to confront the different interests. The ammonia emissions and slurry productions from farrowing houses, weaner houses, houses for pregnant sows are within very reasonable limits. So the economically and zootechnically justified housing systems, are fully acceptable. The, for sanitary reasons, compartmentalized weaner house consists of f.i. 2 x 6 pens for groups of ca. 10 piglets and are equipped with fully slatted floors. The house for pregnant sows consists of f.i. two of individual stalls with half-slatted floors. Group housing of pregnant sows in pens with fully slatted floors and provided with boxes for electronic feeding of concentrates is an alternative, where however from the point of view of animal welfare, management and rentability a few queries are in order (Maton ea., 1990).

Housing of finishing pigs in strawed pens or in strawless, fully slatted pens leads almost to the same, rather important ammonia emission. From strawless pens with half-slatted floors this emission is much lower and, in absolute figures, even limited. Labour demand in strawed Danish houses for finishing pigs amounts to 1.1 man-hour (slaughter pig against only ca. 0.25 man-hour) slaughter pig in slatted floor houses. Strawed housing leads to solid manure which is more appreciated than liquid manure. Zootechnic results are better in half-slatted pens than in fully slatted pens, which however demand a lower investment. Animal welfare can be considered as being somewhat better on half-slatted than on fully-slatted floors.

Everything taking into consideration a strawless house for finishing pigs with half-slatted floorings is a good compromise.

**In poultry housing** one must distinguish between housing of layer hens and broilers.

Housing of layers in cages gives excellent results from the point of view of management, hygiene, quality of the eggs and environmental nuisance is lower than from houses. Now that EEC-measures have preserved animal welfare in them, there is no reason to refuse to keep layers in normalized cages. In recent years there is however a trend to house layers in "voliere" where they get more exercise.

From the littered house for broilers ammonia emission is high but an alternative is not available: cage-housed broilers often show breast blitters which catastrophically decrease the slaughter quality.

- We hope to have made it clear that in housing of animals a compromise must be sought, reaching for an equilibrium between different: factors and not giving one factor the full weight.

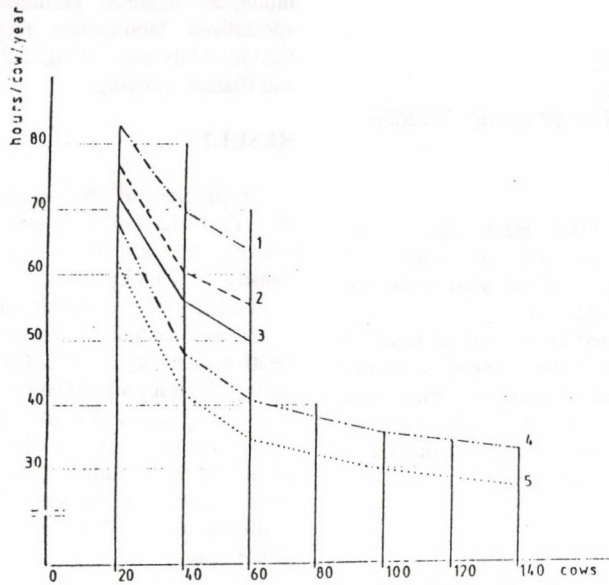

Legend: 1 - littered stanchion barn, hand feeding, milking machine;  
 2 - littered stanchion barn, mechanical feeding, pipeline milking installation;  
 3 - stanchion barn with grids, hand feeding, pipeline milking installation;  
 4 - cubicle house, mechanical unloading of silage, herringbone milking parlour;  
 5 - cubicle house, mechanical unloading of silage, herringbone milking parlour and automatic cluster removal

FIGURE 1.  
 Labour requirement in different types of dairy houses and according to their size (hours/cow/years)

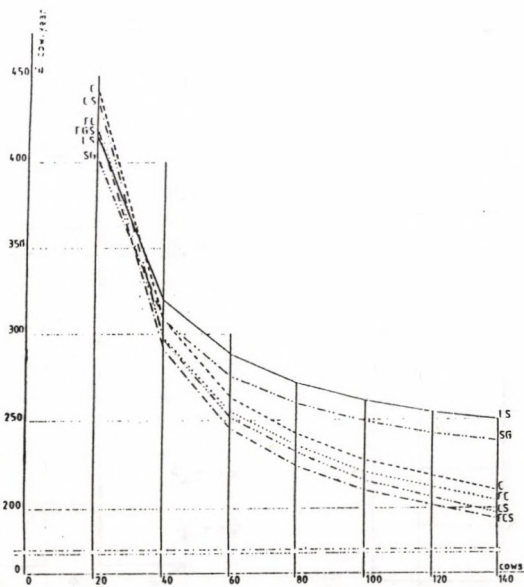

Legend: CS - cubicle house with slatted floors in the passages; C - cubicle house without slats in the passages; FCS - fedd cubicles with slats in the passages; FC - feed cubicles without slats in the passages; SG - stanchion barn with grids; LS - littered stanchion barn

FIGURE 2.  
 Annual costs of dairy house in relation to its size (GBP/cow)

# HEAT- AND MATERIAL TRANSPORT PROCESS IN DRYING OF SEED PEAS

Dr. J. CSERMELY - Dr. Z. BELLUS -  
Dr. M. HERDOVICS - GY. KOMKA  
Hungarian Institute of Agricultural Engineering, Gödöllő

## PRELIMINATIES AND OBJECT

In the scope of an OTKA theme titled "Heat - and material transport in processing of seed and their correlation with biological characteristics" drying process of seed peas was examined in the years of 1991 and 1992.

It was necessary to obtain detailed knowledge as much as possible on drying process of seeds and the connections among technical parameters of drying and storage and biological, physical characteristics. In the frame of this short study our object was only to analyse drying process and to examine its correlation with the characteristics of germination.

## CONDITION AND METHODS

Drying process of seed peas was followed with attention in a KCT 27-54-77 type drying tower, adjusted with vertical vent pipe, in different heights along the radius of the tower.

Within the scope of the research work physical characteristics of peas (e.g. moisture, density, temperature) during loading and unloading, as well as the air, drying technical and energetic features were determined.

Measuring and sampling points of features are shown on Fig.1. Examination were carried out at a seedplant of the University Training Farm of Gödöllő University of Agricultural Sciences at Kartal.

For determining the interaction between drying process and biological features, germination tests were carried out in specialized laboratories (Agricultural Qualifying Institute; Gödöllő University of Agricultural Sciences, Faculty of Genetic and Plant Improving.)

## RESULTS

In the year of 1991 examinations were accomplished with PE-045 variety of seed peas having a mass of 17.7 tons, an average moisture of 17.0 %, a cleanliness of 95.6 % and a density of 723.8 kg/m<sup>3</sup>.

Features of the hot-air blower transported air current were as follows: output 13,000 m<sup>3</sup>/h, average temperature 40.0 °C relative humidity 26.2 %. On six measuring level of the tower casing changing of moisture was registered in different heights and drying times. Results are shown on Fig.2. Equations of graphs are also shown on the figure. According to the changing of moisture in samples from the surface of the tower casing, most intensive drying was found on the lower part of the tower while the most unfavourable states were found near the surface of the heap.

These results are also backed up by the velocity of the coming out air flow measured at the casing. While the average air velocity at the three lower casing rows was 2.7 m/s, this value was only 0.77 m/s at the upper casing surfaces. Excepting peas at the upper casing elements drying finished during 21.5 hours.

Taking into consideration the changing in density during drying process, making better drying conditions of this critical area could be probably attainable by changing the position of the cannon plug in the course of drying. In the year of 1992 examinations were carried on with SSF variety of seed peas

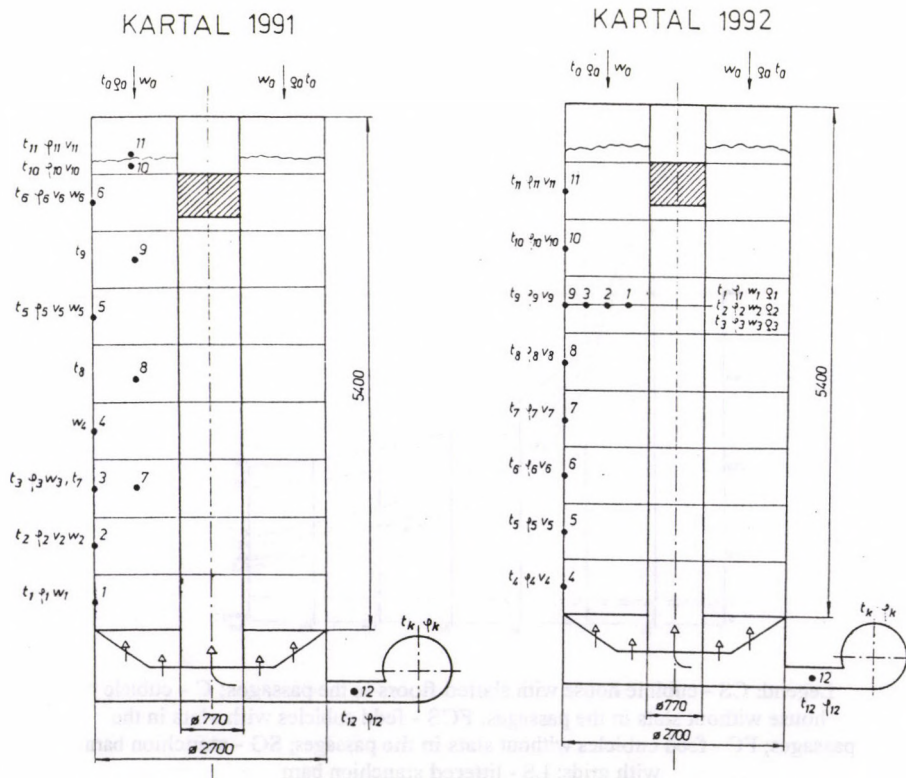

FIGURE 1.  
Measuring and sampling points during examinations of 1991 and 1992

having a mass of 16.3 tons, an average moisture of 16.1 %, a cleanliness of 96.8 % and a density of 703.2 kg/m<sup>3</sup>. Features of pre-heated drying air current were as follows: output 16.010 m<sup>3</sup>/h, average temperature 37.3 °C, relative humidity 28.2 %.

Changing in moisture of pea samples, taking from three level in radial direction plotted against drying time is shown on Fig.3. Equations of graphs are also shown on the figure. Inner layers, near the centre, were dried at an earliest while in the case of outer ones at first a slow moistening then a gradual drying could be observed.

According to the previously mentioned process an about 1.0 % initial difference between moisture values of inner and outer layers attained the maximum value (about 3.0 % difference of moisture) at the 6th hour of drying, then the value that was accordance with the initial one in dried state after about 15 hours drying.

According to the results of germination tests were no important differences among samples taking at loading and unloading. Number of seeds capable of germinating was

80-92 %. This value corresponds to the 1st and 2nd class categories. According to the results of tests, drying process caused no kind of harmful effects on germination features of seed peas.

## CONCLUSIONS

On the basis of years of research works and results of examinations following general conclusions can be drawn:

- Intensity of drying process reduces depending on increasing of height and radius of drying tower.
- Drying of grain layer on upper part of the tower is basically determined by there adjustment of the technology.
- Drying in the near casing layer in radial direction begins after re-moistening.
- Drying, with given technical - technological features, does not exercise harmful influence on germination features.

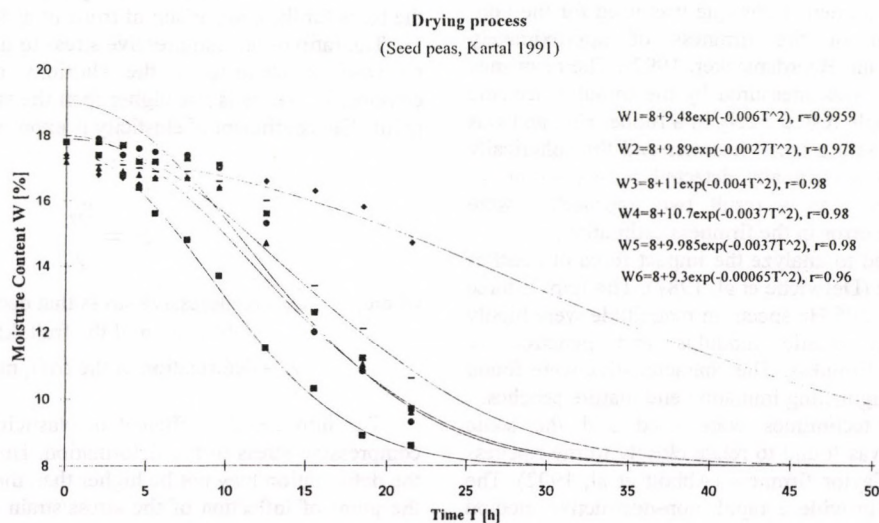

FIGURE 2.  
Changing of moisture at six points along the highs of the tower

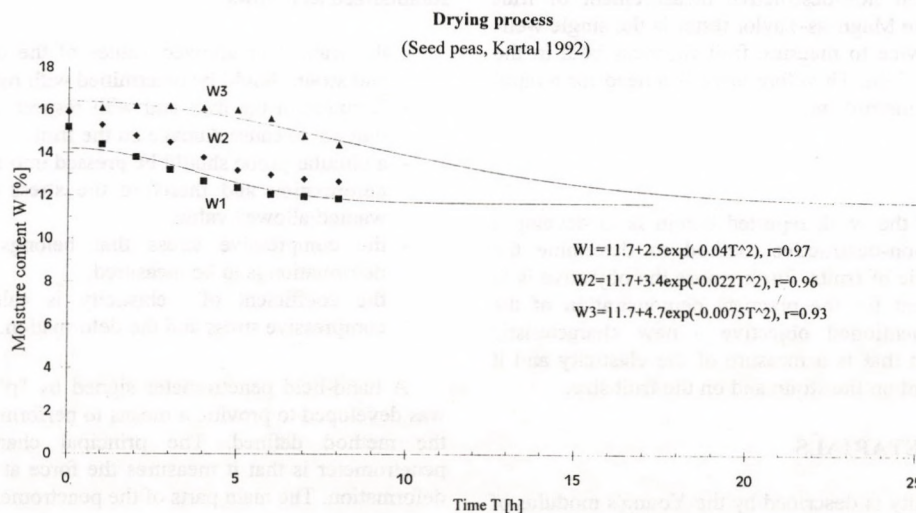

FIGURE 3.  
Changing of moisture at three points in radial direction

# NON-DESTRUCTIVE METHOD OF FRUIT ELASTICITY DETERMINATION

Dr. A. FEKETE  
University of Horticulture and Food Industry, Budapest

## INTRODUCTION

Efforts have been made to develop an appropriate method to determine the firmness of fruits. Naturally, especially lately, fast and non-destructive methods are preferable to others. In spite of the mentioned efforts the Magness-Taylor method is used by many research workers and in the practice as well. According to this method puncture test is performed by a probe of definite geometry to determine the MT firmness.

However many other methods have been developed. A non-destructive impact tester was developed and used to determine impact parameters of apples and pears (Jaren Caballos, C. et al, 1992). This instrument has a 50 g steel rod with a spherical tip of 0.94 cm radius curvature to be dropped from a 4 cm and 3 cm height onto each pear and apple, respectively. The acceleration is measured and impact parameters are calculated.

A resonance measurement technique was used for the non-destructive evaluation of the firmness of approximately spherical fruits (Chen and Baerdemaeker, 1992). The resonance frequency of the apple was measured by the impulse acoustic technique when the apple rested freely in a rubber ring and was excited by striking it with a small hammer and the spherically vibrational signal was acoustically detected by a microphone fixed below the apple. As a result two approaches were proposed to reduce the error in the firmness estimation.

A method was used to analyze the impact force of peaches striking a rigid surface (Delwiche et al, 1987). The impact force characteristics and the 295 Hz spectrum magnitude were highly correlated with fruit elastic modulus and penetrometer measurement of flesh firmness. The characteristics were found to be suitable for distinguishing immature and mature peaches.

Sonic resonance techniques were used and the sonic resonance frequency was found to relate closely to the ripeness scores and Magness-Taylor firmness (Abbott et al, 1992). The sonic resonance may provide a rapid, non-destructive method that could be used for fresh apple ripeness classification when supposing that firmness is the dominant attribute of the ripeness.

The publications and research reports show different methods of rapid and non-destructive measurement of fruit firmness. However the Magness-Taylor tester is the single well-known hand-held device to measure fruit firmness both in the laboratory and in the field. Therefore there is a need for a rapid method and a simple instrument.

## OBJECTIVE

The objective of the work reported herein is to develop a rapid and simple non-destructive method to determine the elasticity characteristic of fruits. Furthermore the objective is to develop an instrument for the practical demonstration of the method. For the mentioned objective a new characteristic should be introduced that is a measure of the elasticity and it should be independent on the strain and on the fruit size.

## METHOD AND METARIALS

In general the elasticity is described by the Young's modulus of elasticity. This is appropriate for materials according to Hooke's law, e.g. for steel, the elasticity of which is linear. For a specimen of linear elasticity the Young's modulus for compressive and tensile stresses is as follows:

$$E = \frac{\delta}{\epsilon}$$

where:  $\delta$  - stress, MPa  
 $\epsilon$  - strain (specific)

$$\epsilon = \frac{\Delta l}{l}$$

where:  $\Delta l$  - variation in the length (deformation), mm  
 $l$  - length, mm

However agricultural materials can be described by rheological models because of their visco-elastic character.

With rheological materials the compressive stress and strain relationship is independent on the length, or on the size of the specimen. Therefore the Young's modulus cannot be used to characterize the elasticity of the agricultural produces and to be the basis for the comparison of fruits of different firmness.

The ratio of the compressive stress to the deformation could be used to characterize the elasticity of fruits where the compressive stress is not higher than the stress at the inflection point. The coefficient of elasticity is expressed as follows:

$$e_c = \frac{\delta_z}{Z}$$

where:  $\delta_z$  - compressive stress that occurs at "z" deformation of the fruit, kPa  
 $Z$  - deformation of the fruit, mm

The introduced coefficient of elasticity is the ratio of the compressive stress to the deformation. However the stress and the deformation may not be higher than the values belonging to the point of inflection of the stress/strain curve. Therefore the deformation is below the permanent deformation and the fruit tested by the mentioned compressive stress will not be damaged.

The method developed by the coefficient of elasticity is summarized as follows:

- the wanted or allowed values of the compressive stress and strain should be determined with respect to the firmness of the fruit and with respect to the requirement that not to cause damage on the fruit,
- a circular probe should be pressed into the fruit where the deformation and therefore the stress is limited to the wanted/allowed value,
- the compressive stress that belongs to the allowed deformation is to be measured,
- the coefficient of elasticity is calculated from the compressive stress and the deformation.

A hand-held penetrometer signed by "p" in the following was developed to provide a means to perform tests according to the method defined. The principal characteristic of the penetrometer is that it measures the force at a present definite deformation. The main parts of the penetrometer are as follows:

- replaceable probe of 6 mm diameter,
- frame to limit penetration for the wanted deformation (0.6 mm for apple and tomato),

- force transducer,
- handle,
- microcomputer to measure and to calculate results, to store and display data.

Comparative test were performed with three different penetrometers:

- with the "p" penetrometer,
- with a simple hand-held penetrometer (signed by "MT" in the following) to determine the Magness-Taylor rupture stress (plunger diameter: 8 mm),
- with an electrical penetrometer (signed by "f" in the following) to determine the stress-strain behaviour, or stress-deformation curves and this penetrometer is fitted with force and displacement transducers.

Apple and tomato were tested by the penetrometers. The measured and calculated characteristics are as follows:

- the coefficient of elasticity was determined from the results measured by the "p" penetrometer, where the force was measured at a definite - 0.6 mm - deformation,
- the Magness-Taylor rupture stress measured by the "MT" penetrometer,
- the stress-deformation behaviour, including stress and deformation at the inflection, bioyield and rupture points and the coefficient of elasticity.

## RESULTS

In general the coefficient of elasticity was calculated from the data measured by the "p" penetrometer. However this coefficient was calculated from the range of the stress-deformation curve being below the inflection point (measured by "f" penetrometer). The relationship between the two coefficients was determined for apple and tomato (Fig.1).

The coefficient of elasticity (measured by "p" penetrometer) was shown as the function of the bioyield and rupture stresses (measured by "f" penetrometer) for apple (Fig.2). The probability level is 5.0 % for both cases.

The coefficient of elasticity (by "p" penetrometer) was analysed as the function of the bioyield and rupture stresses (by "f" penetrometer) for tomato (Fig.3). The probability level was found to be 1.0 % for the bioyield and 5.0 % for the rupture stress.

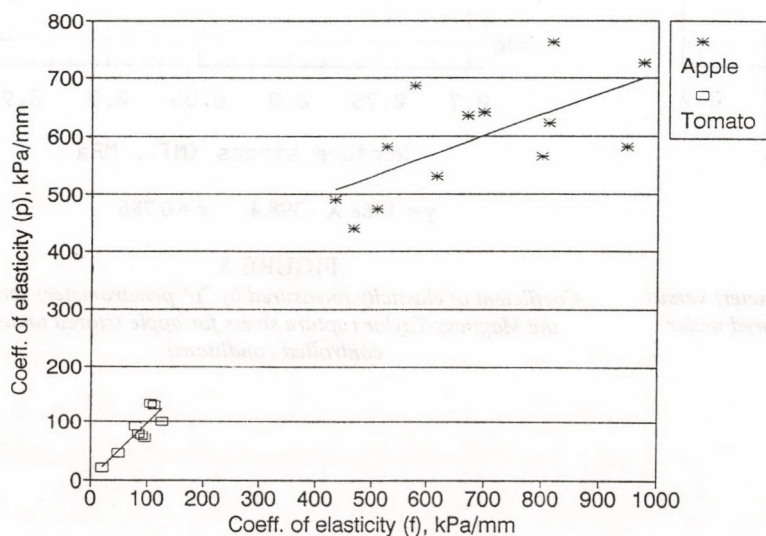

FIGURE 1.

*Coefficient of elasticity (measured by "p" penetrometer) versus the coefficient of elasticity calculated from the stress-deformation curve (measured by "f" penetrometer) for tomato and apple*

$$\text{for tomato: } y = 0.963 X + 1.377$$

$$r = 0.864$$

$$\text{for apple: } y = 0.353 X + 354.3$$

$$r = 0.650$$

The coefficient of elasticity (by "p" penetrometer) was depicted as the function of the Magness-Taylor rupture stress for apple, for two different sample series: for apples stored under room conditions (Fig.4) and apples stored under controlled conditions (Fig.5). There is a close correlation between the two analyzed variables.

## CONCLUSION

A non-destructive method was developed to determine fruit elasticity and the coefficient of elasticity was introduced. The coefficient is the ratio of the compressive stress to the deformation.

The coefficient of elasticity shows a close correlation with the bioyield stress and an acceptable correlation with the rupture stress for apple and tomato. However a close correlation was found between the coefficient of elasticity and the Magness-Taylor rupture stress for apple.

Consequently the coefficient of elasticity can be used to characterize the stress-strain behaviour of the fruits and it can be a good characteristic of the firmness for both scientific and practical evaluation. The "p" penetrometer developed is a good means for the non-destructive measurement of the elasticity of agricultural produces.

## References

1. Abbott, J. A.; Affeldt, H.A.; Liljedahl, L.A., 1922, Firmness measurement of stored "Delicious" apples by sensory methods, Magness-Taylor, and sonic transmission, J. Amer. Soc. Hort. Sci. 117 (4) 590-595.
2. Chen, H.; De Baerdemaeker, J., 1992, Effect of the apple shape on the reliability of the non-destructive firmness sensing, AGENG 1992, Uppsala, Paper No. 9211 115, p. 16.
3. Delwiche, M.J.; McDonald, T.; Bowers, S.V., 1987, Determination of peach firmness by analysis of impact forces, Transactions of the ASAE 30 (1): 249-254.
4. Fekete, A., 1993, Method for determination of fruit elasticity, Conference on Agricultural Engineering, (MTA-AMB) Gödöllő, p. 30.
5. Jaren Caballos, C.; Ruiz-Altisent, M.; Perez de Ruerda, R., 1992, Sensing physical stage of fruits by their response to non-destructive impacts, AGENG 1992, Uppsala, Paper No. 9211-113. p. 12.
6. Magness, J.R.; Taylor, G.F., 1925, An improved type of pressure tester for the determination of fruit maturity, U.S. Dept. Agr. Circ. 350, p. 8.

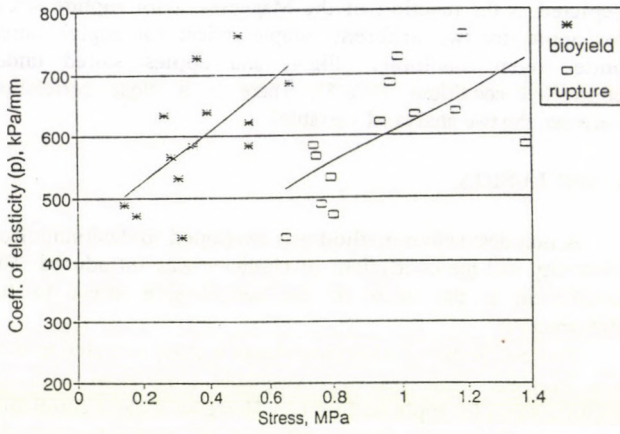

for bioyield stress:  $y = 406.3 X + 444.5$   $r = 0.626$   
 for rupture stress:  $y = 285.6 X + 327.8$   $r = 0.627$

FIGURE 2.

Coefficient of elasticity (measured by "p" penetrometer) versus the stress (measured by "f" penetrometer) for apple

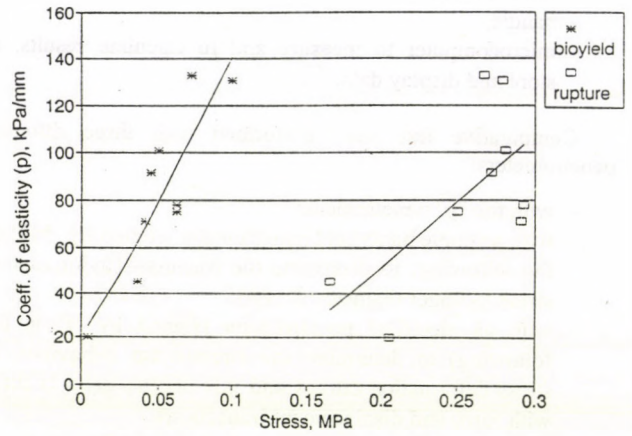

for bioyield stress:  $y = 1216 X + 18.94$   $r = 0.876$   
 for rupture stress:  $y = 552.5 X - 58.55$   $r = 0.654$

FIGURE 3.

Coefficient of elasticity (measured by "p" penetrometer) versus the stress (measured by "f" penetrometer) for tomato

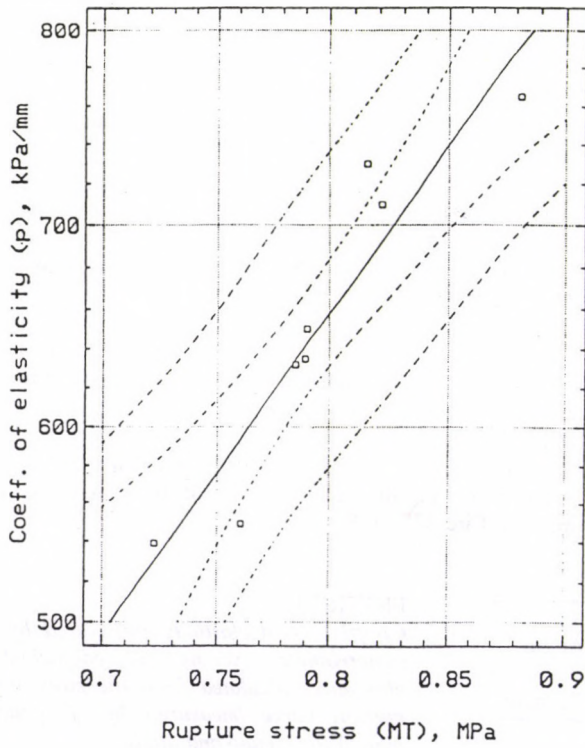

$y = 1635 X - 650.5$   $r = 0.938$

FIGURE 4.

Coefficient of elasticity (measured by "p" penetrometer) versus the Magness-Taylor rupture stress for apple (stored under room conditions)

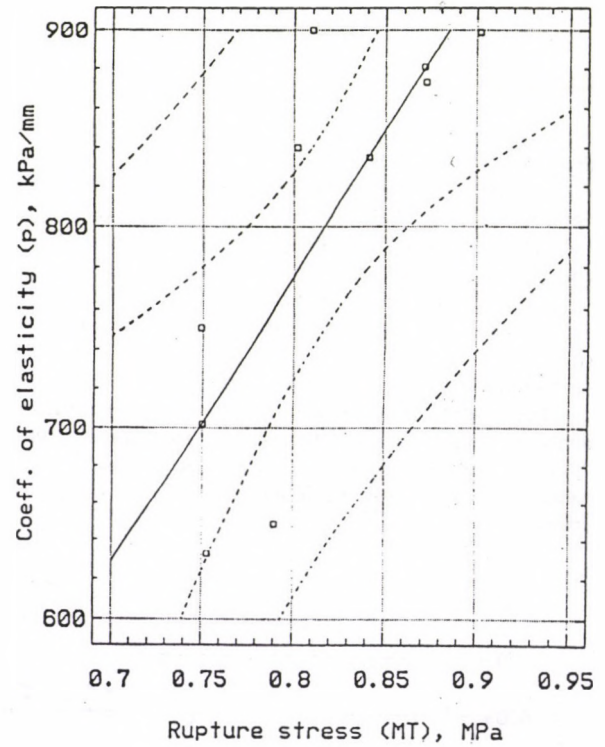

$y = 1468 X - 398.4$   $r = 0.786$

FIGURE 5.

Coefficient of elasticity (measured by "p" penetrometer) versus the Magness-Taylor rupture stress for apple (stored under controlled conditions)

## WARMING UP OF BARLEY GRITS IN HAMMER-MILL (OTKA)

Dr. I. BÖLÖNI - Dr. J. CSERMELY - S. SALAMON  
Hungarian Institute of Agricultural Engineering, Gödöllő

The warming up has a very important role in the comminution process and at the determination of the hammer-mill's technical efficiency (%). That is why the relevant results of an earlier investigation [1] carried out by a hammer-mill, type D-24 supplied with fan for pneumatic grits conveying have been evaluated from this point of view. Barley sort of Beta-40, having 13.5 % water content on wet base, was ground at a detailed research program concentrated on the operational technique of the mill using screens of 3-5 and 12 mm hole diameters. No screen tests also were done. The temperature of the whole feed grain before grinding and that of the grits was measured after comminution. In order to get the special energy requirement of grinding the net power consumption (without all power losses) and the grinds flow rate were determined.

In this paper actually will be just the interdependence of

- the particle mean size:  $x$  (mm)
- the specific surface area of the grinds:  $f_d$  ( $\text{cm}^2/\text{g}$ )
- the specific grinding energy requirement:  $e_d$  ( $\text{kWh}/\text{t}$ )

examined.

It should be mentioned, that the characteristics of the particle size distribution were determined by means of a TYLER set, having 7 sieves + pan. The feed flow rate ( $\text{t}/\text{h}$ ) was stabilized by help of a cell-type feeder.

The relevant results of the investigations, including the regression functions are in Fig.1,2 and 3 to be seen. The regression parameters are collected in the Table 1.

On the bases of the above data the following important statement could be taken:

1. The linear relations  $\Delta t(1/x)$  (Fig.1) and  $\Delta t(f_d)$  (Fig.2) have something common: neither the first one, nor the second one is interpreted, when

$$0 < 1/x < 1/x_0 = 1/3,84 \text{ mm} = 0,26 \text{ mm}$$

and

$$0 < f < f_0 = 12 \text{ cm}^2/\text{g}$$

where:  $x_0 = 3.84$  mm is the starting mean size of the feed grain,

$f_0 = 12 \text{ cm}^2/\text{g}$  the specific surface area of the barley before grinding.

That is why the straight line of the regression function starts in the first case from the point  $x_0 = 3.84$  mm (i.e.:  $1/x_0 = 0.26 \text{ mm}^{-1}$ ) and in the seconds one from  $f_0 = 12 \text{ cm}^2/\text{g}$ . But theoretically the function at these points of abscissa should have a value  $\Delta t = 0$ , since there is no warming up before grinding. This problem might be eliminated using a logarithmic - or root - etc. regression functions.

Otherwise the tightness of the correlation is just the same at both relations ( $r_x = 0.44$  and  $r_{f_d} = 0.431$ ).

This could be simply explained by the first grade hyperbolic interdependence of the particle mean size ( $x$ ) and the specific surface area ( $f_d$ ) of the grind. The determination coefficients (as the square of the correlation coefficient) show (Table 1) that the grits fineness ( $x$  and  $f_d$ ) takes apart in the developing of the grits warming up just by 18-19 %.

2. The linear relation  $\Delta t(e_d)$  (Fig.3) starts off the point  $\Delta t = 6.883 \text{ }^\circ\text{C}$ , when  $e_d = 0$ , which is not to be explained on physical bases, just because before giving over energy to the grain any temperature increase could exist. The curve of the function should start off the point 0-0. Later on application of logarithmic - or root - etc. regressions would rather do.

The correlation coefficient is quite small ( $r = 0.228 < 0.4$ ), therefore the interdependence between the too variable is quite loose. So that the specific grinding energy requirement could cause the temperature increase of the grits only in 5 %. That is a surprise, since the comminution is a heat process in great deal, in which the specific grinding energy requirement should play a greater role.

3. The low grade of correlation at all regressions might have been caused by the inferior accuracy of measuring methods for determining the fineness of grinds and even the  $\Delta t$  temperature increase of grits. These are to be developed by all means.

4. Because of the previous problem further research is needed: in what extent might  $\Delta t$  temperature increase be influenced by such characteristics of comminution like time of grinding, load quantity, feed flow rate etc.?

### References

1. Bölöni, I., Theorie, 1980, Technik und Anwendung von Hammermühlen in der Futtermittelindustrie, Aufbereitungstechnik, Wiesbaden, N 5, p. 245-252.

**Table 1.**  
**Regression parameters for the grits temperature increase**

Sign	Regression relation	Regression		Correlation	Determination
		coefficient	constant		
1.	$\Delta t(1/x)$	3.689 mm	5.036 $^\circ\text{C}$	0.440	0.1936
2.	$\Delta t(f_d)$	0.042	5.526 $^\circ\text{C}$	0.431	0.1857
3.	$\Delta t(e_d)$	0.075	6.833 $^\circ\text{C}$	0.228	0.052

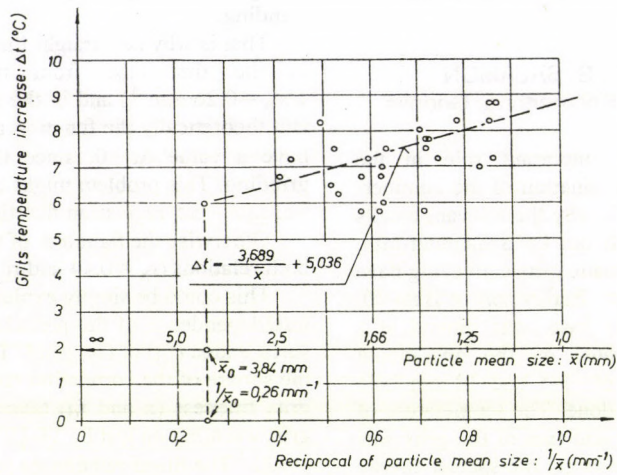

FIGURE 1.  
Warming up of barley grinds ( $\Delta t$ ) as a function of the particle mean size ( $1/x$ ) and it reciprocal value ( $1/x$ ). Mill type: D-24

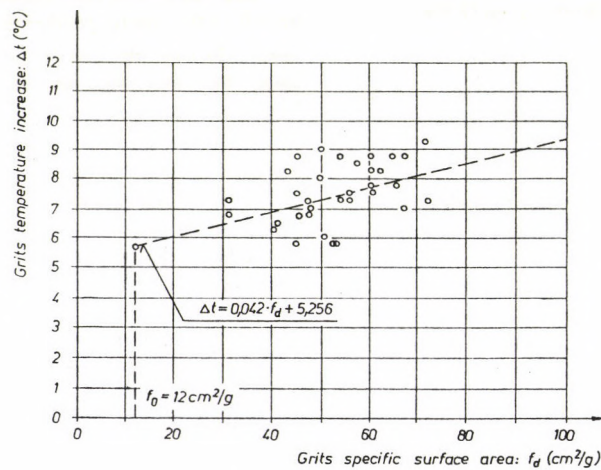

FIGURE 2.  
Warming up of barley grinds ( $\Delta t$ ) as a function of the grits specific surface area ( $f_d$ ). Mill type: D-24

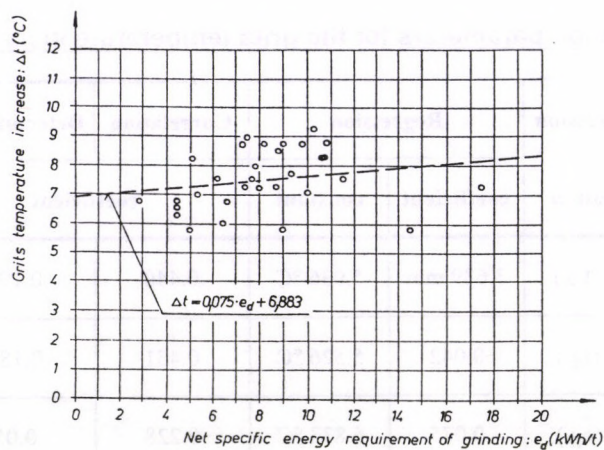

FIGURE 3.  
Warming up of barley grinds ( $\Delta t$ ) as a function of the specific grinding energy requirement ( $e_d$ ). Mill type: D-24

# APPLICATION POSSIBILITIES OF SOLAR AND WIND ENERGIES IN THE ENTERPRENEURIAL ANIMAL FARMING

Dr. L. TÓTH - Dr. J. BAK - P. PECZNIK  
Hungarian Institute of Agricultural Engineering, Gödöllő

## INTRODUCTION

The home sheep farming - by transforming the structure of production can-be an economical export goods producing branch. Transforming of production structure the significant part of sheep keeping will be realized on such grassy fields where is no electricity and water supply. Suitable light is required to do the works of care (especially to the yearning), however safety continuous fresh water supply is required to the safety production. On the case of milking there is need for hot water. On these areas the modern and economical methods of drinking- and hot water and electricity supply can be based on solar and wind energies.

## THE OBJECT OF DEVELOPING WORK

The aim of the work was to plan the water supply by wind-machine, the electricity supply by solar cells an the warm water supply by solar collectors for a sheep farm having 100-150 ewes. The object of the work were to select the elements of systems to buy them to put them in operation, to test them by experiments and by collecting the operation data too. Our work was supported by OMFB in 1992.

## RESULTS

### Wind Powered Water Supply

The daily water demand was 9.5 l/sheep taking the drink water, the technological and communal requirements and 20 % reserve into consideration. So the total daily water demand of the farm was 1500-2000 litres According to the local wind data the longest calmness period lasts 3-5 days. A water tank of 10 m<sup>3</sup> storage capacity is suitable for 6 day's demand was to planned to built in besides the wind-machine. In the dug well belonging to the farm the water level can be expected in 2-5 m deep from the ground surface. On the farm situated in the surroundings of Debrecen the 70-75 % of wind energy by the wind speed measurements falls to the range of 3-6 m/s. The wind-machines are not able to utilize the wind having speed under 3 m/s. The winds having greater speed 6 m/s are rare and have short period. Accordingly to the measurements of six month, the energy content of wind at 15 m high is 620 kWh/m<sup>2</sup>. Knowing of wind conditions, the well and water demand the multiple-blade SZV-2 type wind-machine was designed and was built-in.

Nominal data of the system are the followings:

- rotor diameter	2,4	m
- no.of blades	12	pc.
- starting wind speed	3	m/s
- down-control wind speed	9	m/s
- nominal water flow rate	24-32	l/min
- frame height of wind machine	6	m
- pump: length of stroke	20	mm
- displacement	10.6	dm <sup>3</sup>
- suction connection	32	mm
- pressure connection	32	mm
- suction height	7	m
- pressure height	10	m

## Solar Lighting System

On the farm it was planned to solve the lighting in the sheep fold, the shepherd resting and cooking room, the storage by electric energy generated from solar energy. It was also taken the TV-set and radio-set use in summer time into consideration. The size of the sheep fold is 11.4 x 40 m, namely the basic area is 450 m<sup>2</sup>. The basic area of the cooking room is 12 m<sup>2</sup> the resting room 25 m<sup>2</sup> and the storage room 25 m<sup>2</sup>. Compact and economical neon tubing were planed for lighting, from which 6 pieces (2 x 11 W and 4 x 9 W) were fixed built in and 2 pieces (11 W) were plug in types. The total output of the neon tubing is 80 W.

According to the technical data of neon tubing the 7 W neon tubing is equal with 40 W traditional bulb, and it has 600 ln lighting capacity. Using neon tubing besides the same lighting 80 % of the traditional bulbs energy can be saved, not to speak about that the neon tubing have 8 times longer life time than traditional bulbs have. Since in Hungary the sheep keeping has low profitability, in the planing we take the low cost and the minimum lighting demand into consideration.

Considering these, 12 V D.C. system was chosen, at which the daily energy consumption is 12 VAh. At this energy consumption one 9 W or 11 W bulb is capable to light through 15 or 13 hours (means during the whole night) or this energy is enough to operate all tubing (80 W) for 1.8 hours. From the offers of different firms we considered the offer of SIEMENS Ltd. best, which is shown in Fig.1.

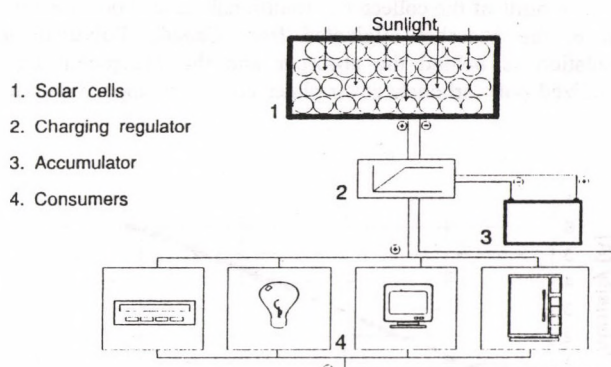

FIGURE 1.

*Scheme of solar lighting system of a sheep farm*

According to the home meteorological data, the most sunny hours are in July, between 270-310 hours (daily mean is 8-10 hours). The minimum of sunshine is 40-50 hours (daily mean 1-1.5 hours) can be measured in December. Comparing the period of effective sunshine to the possible theoretical sunshine period, it is experienced, that the sun shines in 15-20 % of possible period in December and January and 60-65 % in July and August. In the surroundings of setting (Hortobágy) the yearly sunny period is 2000-2060 hours. In cloudless weather the rate of daily radiation is hardly 20 % of which can be measured in the summer months. To have get experience in the field of solar photovoltaic energy production and storage we have set up a measuring circuit consisting of solar cells, charging regulator, batteries and artificial loading which can be seen in Fig.1. The tests were carried out in Gödöllő, September 1992.

The radiometer was fixed to the frame of solar cells. During the day the radiation varied between 50 and 820 W/m<sup>2</sup>. The value of voltage was maintained constant (13.5 V) by varying the artificial load. The processed measuring values are shown in Fig.2,3,4.

In the developed system the charging current intensity of batteries can be expected up to max. 6 A (Fig.2), depending on the momentary radiation. The power output of system increases nearly in direct ratio to the radiation, its expected highest value is about 80 W (Fig.3).

Efficiency of the system calculated on the basis of radiation and output power is low up to 200 W/m<sup>2</sup> radiation and is increasing between 1.8 and 6% and at higher radiation the value is 6-6.5%.

In the time of writing this report the mounting of water and current supplying systems were in process.

### Solar Warm Water System

At the planning we considered the followings: Low costs, the system must be simply and does not need for electricity and circulating pumps. The circulation between the collector and water tank (boiler) can be maintained by the gravitation. The system can be alternatively operated, in sunny period the water is heated by the sun but in cloudy period or when the solar radiation is low the water can be heated by burning agricultural residues in the fireplace of the boiler. The system must be open, so there is no need for pressure tight elements. Constructing the boiler we considered that the water in the boiler must be heated up to 80 °C in an hour. The system is consist of the followings:

- solar collector of 4 m<sup>2</sup> area and the frame,
- water tank of 200 l with the fireplace,
- tubes and fittings.

The built of the collector is traditional. In an iron frame we put in the absorber originated from Canada. Polyurethane insulation is behind the absorber and the transparent light stabilized polycarbonate cover plates are on the upper side. The

absorber plates are mounted parallel each other and slowly rise to the direction of boiler. The boiler is very simple too. The upper part is a barrel of 200 l. We lead across the barrel a pipe of 120 mm diameter for smoke, and applied four pipe connections on the side of barrel. These serve for filling and for the water returning to the collector, for the water coming from the collector, for consuming hot water and for the thermometer. The barrel is wrapped with insulation and with aluminium plate. The fire place under the hot water tank is made from a barrel too. We cut a barrel for two pieces, fixed on three legs, cut on the side a door and to the bottom side we mounted a roast, and inside coated with fire concrete. The tests we made in July and in October that 200 l of water can be heated up to 60 °C in 10 hours in summer, and in fall, when the radiation is low the same amount of water can be warmed up to 80 °C in an hour by firing about 9 kg wood or other combustible agricultural residues (corn-cob or corn-stalk). Analyzing the economical data we found that to warm up 100 l water costs 10.8 Ft and the cost of 1 kWh energy gained from the collector is 1.4 Ft, which is four times cheaper than the electrical energy. Our solar water collector system can be used everywhere where water supply available, and there is no need for other energy, it can be used in the milking sheep farming where is great need for hot water. Since the system can operate alternatively so it can be used not only in summer but winter too.

### References

1. Bak, J; Rétfalvi, F; Bolyós, J, 1992, Utilization of Wind Energy in Small-Scale Sheep Farming, Interim Report, FMMI Gödöllő, p. 53.
2. Tóth, L; Rétfalvi, F; Honti, V, Measuring and Instruments of Wind Energy, Academy Press, Budapest, p. 53.
3. Tóth, L; Honti, V, 1984, Water Lifting and Electricity Generation by Wind Machines, MÉM Technical Institute, p. 57.

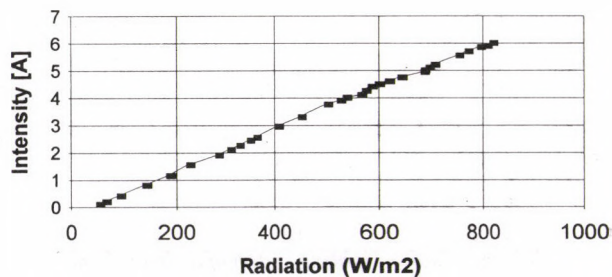

FIGURE 2.  
Effect of the radiation intensity on current

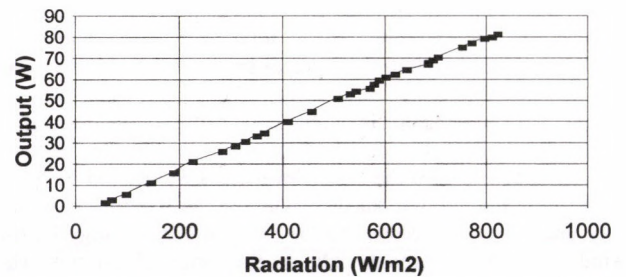

FIGURE 3.  
Effect of the radiation intensity on output

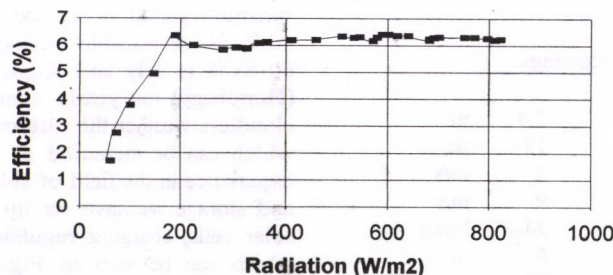

FIGURE 4.  
Effect of the radiation intensity on efficiency

# INTENSIVE MIXING THE CEREAL BULKS BY PNEUMATIC METHOD DURING STORAGE

Dr. K. KACZ - Z. SÁRKÁNY  
PANNON Agricultural University, Mosonmagyaróvár

## INTRODUCTION

It is difficult to create proper conditions for safe grain storing.

In Hungary at about 10 million tons of grain has higher moisture content during the harvesting, than the equilibrium one.

At higher moisture content than the balanced one grain can be stored safely if it is ventilated by environmental or cooled air during storing. In many instances even this method is not satisfactory to prevent formation of rotting parts.

In many cases the moisture content of the parts of the bulk after drying is not constant, because the drier dry usually not evenly. At most of the storers there is no possibility to ventilate the grain. In order to avoid grain perishing the grain is very often overdried, which causes not only surplus energy input but the degradation of nutritive value, too.

The researches of the Department of Agricultural Engineering elaborated a basically new method to protect the grain quality during the storage.

The main point of the patented method [1] is to place elastic, inflatable hoses into the store and by the inflation and deflation of these hoses grain layers can be moved. With this method, on one hand, the forming of rotting part can be prevented, existing centres can be eliminated; on the other hand, the method combined with ventilation can increase the safety on the storing.

The other advantage of the method is that it does not cause mechanical damages to expensive seeds.

During the previous tests the following statements were made [1,3,4]:

- Wet parts in the bulk can be moved toward optional direction resp. mixed by choosing proper moving order,
- As influence of movings the bulk begin to compact. After 50-60 movings density of bulk increases by 8-9 %.

With these experiments our aim was to increase the intensity of the mixing of wet and dry parts of the stored grain.

## MATERIAL AND METHOD

The scheme of the test equipment can be seen on Fig.1. With the help of the valves set into the airheader the hoses can be inflated or deflated in different order. The radius of the semicircle cross sectional hoses is 300 mm. The hoses are settled in equivalent distances (900 mm) from each other. The ventilator ensured 0.35 bar overpressure. The tests were carried out with barley. The moisture content of the roll-shaped wet centres, which were coloured with food paint, was 22-23 % wet basis, and the equilibrium humidity of the grain was 13 %. Two centres were set into same places, e.g. above the hoses or between two hoses, at 500 mm distance from one another. After the movings of the grain was cut into 40 mm stripes. The distorted wet centre areas were photographed and measured.

The ventilating system was built from PVC pipes. The ventilating air has gone through pipes of 110 mm diameter into the storer, while it has gone directly to the grain through pipes of 63 mm diameter.

KONGSKILDE ventilating bars were fixed into the perforated pipes placed in the storer, as it can be seen on Fig.1 the ventilating pipes were set on both sides of the moving units.

The quantity of ventilating air was measured by U-gauge. On one hand we wanted to know whether the intensity of mixing of humid centres could be influenced by ventilating air. Another question is that how we can raise mixing efficiency by intensive moving. Intensive moving means that inflating and deflating of hoses occur simultaneously.

Tests were performed as follows:

1. During the tests the grain was simultaneously moved pneumatically and ventilated. During the tests the speed of ventilating air were changed within 0.02 and 0.1 m/sec.

2. Bulk was moved intensively. The ventilator in throttled stage blew air of  $v=0.04$  m/s speed through the grain. It is equivalent of the ventilatory air quantity used in practice.

## RESULTS

On the basis of tests the following statements can be made (Fig.2):

1. By increasing the speed of ventilating air to  $v=0.08$  m/s intensity of mixing can be raised. In accordance with our observations greater air velocity decreases mixing intensity.

2. Intensive moving raises moving speed of wet parts considerably.

Tests, have been carried out up till now, created the basis of computer modelling of different mixing processes.

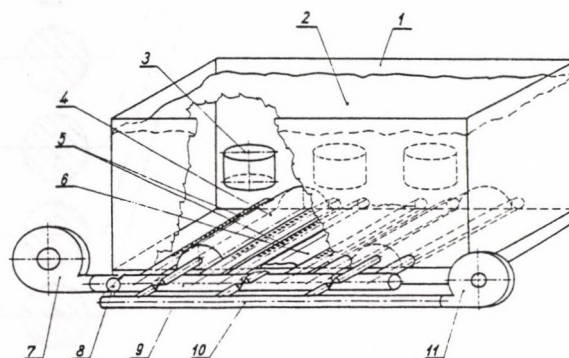

1. Experimental storer; 2. Grain bulk; 3. Humide part;
4. Moving air hose in inflated condition; 5. Perforated pipes for ventilation; 6. Moving air hose in deflated condition; 7. Fan;
8. Manometer; 9. Central pipe for ventilation; 10. Central pipe for deflated and inflated; 11. Compressor

FIGURE 1.  
*Experimental storer*

## References

1. Neményi, M., 1986, Eljárás és berendezés biológiai vagy egyéb szemcsés anyagok, főleg mezőgazdasági szencsés termények energiatakarékos, állagmegővő tárolására, Hungarian patent, No. 196279.
2. Neményi, M.; Sárkány, Z.; Kacz, K., 1991, Moving and ventilation of grain by pneumatic method during storage, Acta Ovariensis, Vol. 34., No. 1., p. 47-55.
3. Neményi, M.; Sárkány, Z.; Kacz, K., 1992, Moving the cereals bulks by pneumatic system, Hungarian Agricultural Engineering, No. 5., p. 24-25.
4. Neményi, M.; Sárkány, Z.; Kacz, K., 1992, Energy saving corn protective storage of cereals by pneumatic system, Conference of Agricultural Engineering Committee of the Hungarian Academy of Sciences of Research and Development, Gödöllő, p. 9.

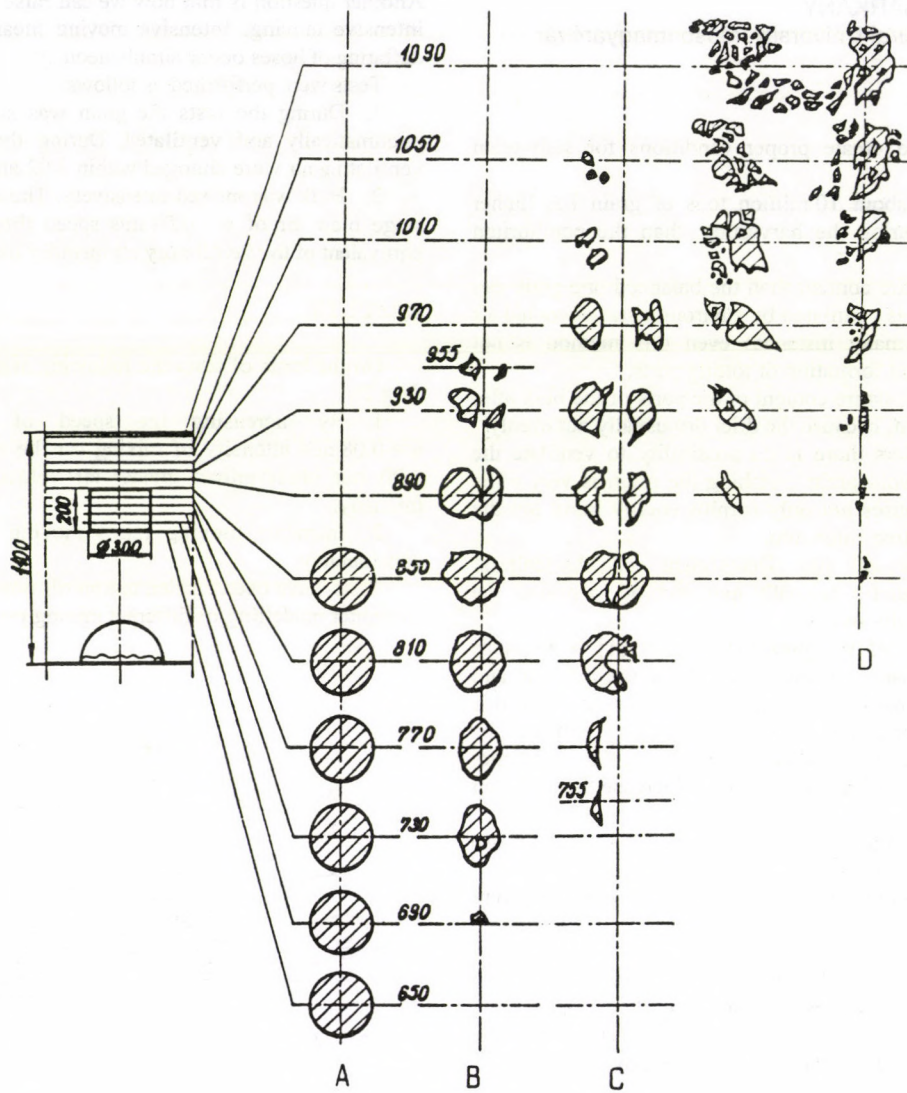

- A - No moving
- B - Moving without ventilation
- C - Moving and ventilation simultaneously
- D - Intensiv moving

FIGURE 2.

Horizontal cross section of wet module and change of their condition and form after 150 moving

# QUALITY CONTROL OF BIOBRIQUETTES AND EXPERIENCES WITH THEIR COMBUSTION

P. PECZNIK - GY. VARGA  
Hungarian Institute of Agricultural Engineering, Gödöllő

## INTRODUCTION

A great mass of combustible waste, by-products and residues originates annually in the different sectors of economy. Especially in the agriculture people can get a great amount of heat energy by burning the plant residues, and stalks (ie.: straw, corn- sunflower stalk etc.), which means a smaller damage to the environment than the burning of fossils fuels.

To burn the biomass in original form one needs special equipment (ie.: big-bale furnace, pre-combustion equipment etc.). These are too expensive and the basic requirement of their rentable use is the continuous and well charged operation.

Since the originating places and the heat demands are not on the same places in the agriculture, one of the possibilities to increase the use of these materials is to density them, to briquette them, whereby making fuel that can be utilized anywhere in the present furnaces and stoves. The inhabitants and families can be the main consumers of these fuels.

Among the producers of briquettes, made of different materials, and among the manufacturers of furnaces and heat equipment the demand has arisen, at the same time, to test the briquette quality and the furnaces with biobriquettes. This is the reason why we have worked out the quality control system of biobriquettes and tested the combustion of more spread biobriquettes in different furnaces.

## METHODS APPLIED

In the course of the tests we have applied our quality control system for briquettes. On this basis prior the combustion experiments we have determined the most important physical and stability characteristics. These are the followings:

- sizes, individual mass, density,
- resistance to abrasive and breaking load.

We have tested mainly briquettes made of straws and those of wood and only a few of other special materials. To test the furnaces and water boilers we have built up a testing unit, suitable to test hot-water boilers from 10 kW up to 50 kW.

Accordingly we have selected boilers which are widespread in households. An important part of the test is the individual burning of briquettes in a special equipment. With its help we can estimate the characteristics of combustion in real furnaces and boilers and can compare the different types of briquettes. During the real combustion in boilers we measured the heat output of boiler, the fuel consumption, the temperature of combustion chamber and that of the different parts of boiler, and flue gases on the basis of the standards. Another significant part of the measuring was the flue gases emission and then comparing this with the environmental regulations.

## RESULTS

The summarized results of some briquettes can be seen in the Table 1. We can see that the density depends on the raw material and the pressing method and is in connection with other mechanical characteristics, but its value itself does not determine the quality.

As the pressing method requires a low water-content, the water content of the briquettes is under 20 %. Most of the biobriquettes have better heating-value than an average brown

coal has. The low ash- and combustible-sulphur-content is advantageous for the environment. The low sulphur-content makes these fuels "environmental friendly".

The size-distribution index and the durability index are fundamentally in connection with the raw material and depend on the pressing method. These indexes and the compressing strength and the dust and broken-content are characterizing the resistance to mechanical effects, occurring during the delivery and storage.

According to our experiments the briquettes, made of small particles, like sawdust and grinding powder, are less solid than others made of bigger particles.

The briquettes, made by screw press, usually have better mechanical parameters than cylindrically made briquettes have. The combustion temperature measured during the individual combustion in the special equipment characterizes the intensity of combustion. On the basis of this we can project the real combustion process in the furnace.

For example let's see two different briquettes made of different materials, but by the same method. (Fig.1,2). We can see that there is a great difference between the intensities of burning and the temperatures achieved.

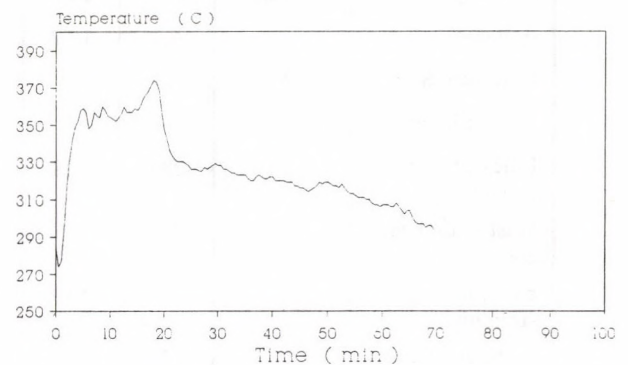

FIGURE 1.  
*Temperature of burning in special equipment  
HEMP-SILVER (three dimensionally pressed)*

The burning of hemp sliver is faster than that of straw. The out-burning of volatile flue gases lasted twenty-twenty five minutes, while in case of straw such a section can't be separated and the burning is very much slower, too. We can forecast from the curves that the hemp sliver will be the better fuel, while the straw the weaker. This has been proven in the course of the burning experiments in the boiler.

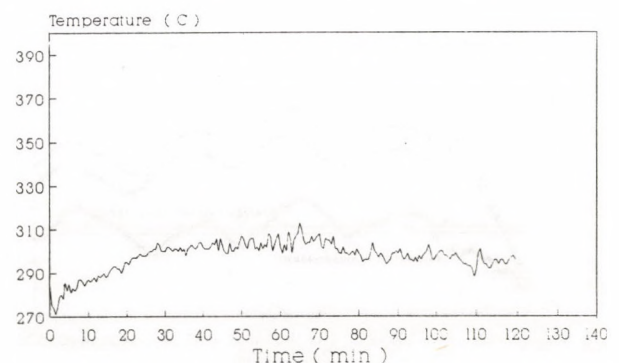

FIGURE 2.  
*Temperature of burning in special equipment  
STRAW (three dimensionally pressed)*

While burning the hemp sliver the heat output of boiler was higher than the nominal, while during the straw burning it was on a lower level. (Fig.3,4). The different pressing methods can also cause differences. For instance with straw briquettes, made by cylindrical press, the heat output of boiler was 28.5 kW, while with briquettes made by screw press the heat output was only 19.8 kW.

The difference was absolutely caused by the pressing method. The flue gases emission of briquettes, made of pure agricultural residues, was very low while the smoke of mixed materials contained undesirable components.

About the different types of boilers it has been proved that they are usually suitable to burn biobriquettes except the two chambered boilers, where problems occurred with the primer and secondary air supply.

**Table 1.**

**Testing results of different biobriquettes**

Characteristics of quality	Dimension	Testing results								
		Straw			Wood			Other		
		base briquettes								
		1.	2.	3.	1.	2.	3.	1.	2.	3.
Density	g/cm <sup>3</sup>	1.1	1.2	0.6	0.9	1.2	0.7	1.2	1.2	0.6
Water cont.	%	7.6	10.0	8.0	8.5	7.2	8.5	11.0	10.5	7.6
Heating val.	MJ/kg	15.3	14.3	16.3	16.5	16.9	16.5	17.5	16.5	17.4
Ash cont.	%	4.3	10.2	7.5	1.5	1.5	1.6	3	6.6	3.7
Combust. Sulp.	%	0.2	0.1	0.2	0.2	0.2	0.2	0.2	0.4	0.1
Durability index	%	96	99	98	90	99	98	97	91	89
Index of size distrib.	-	285	398	398	213	399	398	397	391	389
Dust & broken cont.	%	2.5	0.5	1.1	6	0.2	-	1.4	0.5	-
Compressing strength	kN	2	>10	6	1.5	>10	5	4	>10	5
Temperature of combust.	°C	425	440	360	480	485	455	-	430	-
Rate of heat output	%	87	66	49	92	120	-	-	93	100

- Straw 1.: Straw briquette from Jaszdózsza
- Straw 2.: Straw briquette from Dujv.(paper mill)
- Straw 3.: Straw briquette three dimensionally pressed
- Wood 1.: Sawdust briquette from Eger
- Wood 2.: Sawdust briquette from Gyöngyös
- Wood 3.: Sawdust briquette three dimensionally pressed
- Other 1.: Fur-furol briquette
- Other 2.: Scrap leather briquette (experimental)
- Other 3.: Corn-cob briquette three dimensionally pressed (experimental)

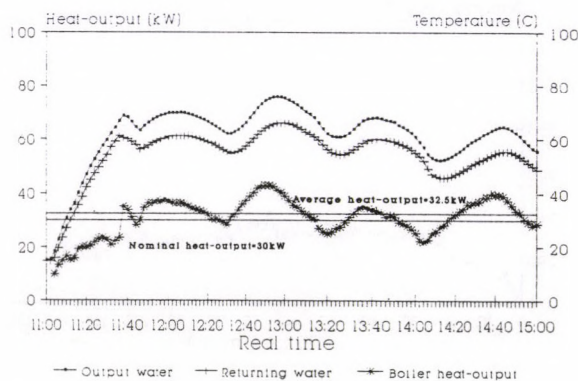

**FIGURE 3.**  
*Heat-output of boiler*  
HEMP-SILVER (three dimensionally pressed)

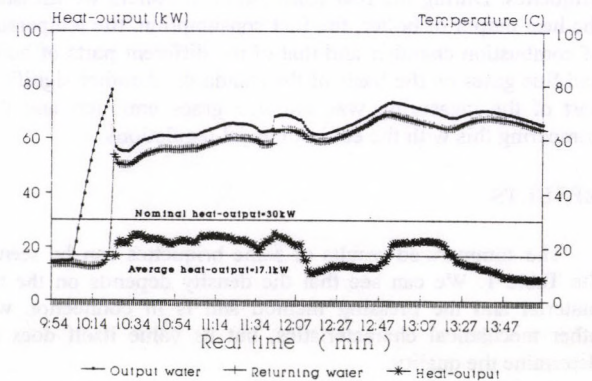

**FIGURE 4.**  
*Heat-output of boiler*  
STRAW (three dimensionally pressed)

# APPLICATION POSSIBILITIES OF FINITE AND BOUNDARY ELEMENT METHODS IN CLIMATE CONTROL DESIGN OF GREENHOUSES

Dr. F. KASZA  
University of Agricultural Sciences, Gödöllő

## INTRODUCTION

In the Gödöllő University of Agricultural Sciences, Faculty of Agricultural Engineering, Department of Mechanics and Engineering Design efforts are made for several years to modernize the obsolete research structure and topics with taking into account the expectable demand of practice and the international agricultural engineering research trends. Despite the inner and outer circumstances of institution are unfavourable slight advance has been achieved. The most important to move from the existing agricultural technical contemplation to a complex agricultural engineering way of thinking. Some work of our departments is in this sphere. Although, unfortunately, some conditions are counterchecking educational applications are also promoted.

The modern research demands complex approach to problems to solve. It is a consequence of the existing results, knowledge and the variety of solution tools available and the problems are also rather complicated. It is understood that fruitfulness of research can be greatly increased by means of complex application of modelling, calculations and measurements. Being aware of the foregoings the topic of this paper is only modelling.

It can be observed the expansion of complex environment modelling topics in the international research practice. A most important topic of microclimate modelling is the research on physical, technical and technology characteristics of microclimate control of agricultural utilization greenhouses. In Hungary the role of glasshouses will increase forced by uniform quality need and land turning to desert even if this forecast is generally refused even in official opinions.

The share of our Chair in this research is the computer modelling development and application. The engineering base is formed by our results including:

- Finite Element Method (FEM) and Boundary Element Method (BEM) program development for statics,
- program development for dynamics,
- FEM and BEM program development and application for potential problems (heat, flow, diffusion, etc.),
- application and development block system time based simulation,
- design and simulation in space and time making use of general purpose high quality computer program packages.

## TARGET AND SCOPE OF THIS PAPER

This paper is an expounding of the author's opinion about applicability of numerical methods in this important field of agricultural engineering and contains no concrete research results neither references. The paper is not a usual review of literature but rather a condensation of author's knowledge of the theme generated by some discussions with acknowledged experts of the field. Author has been convinced that adaptation of numeric methods, especially FEM and BEM can give considerable contribution to climate control design. It is a trial to point out the way how the FEM and BEM modelling of glasshouse, greenhouse and foil tent microclimate can be imagined. Computer modelling can be great help, but until the wide and reliable application many drawbacks should be eliminated.

## BASIC POSSIBILITIES OF FEM

Before discussing FEM it is practical to touch that in spite of wide spread of FEM boundary element method is much more promising and comfortable especially in this topic which usually leads to huge numeric problems. The practical acceptance of BEM is much smaller now than that of FEM, but BEM will squeeze out FEM from most application fields in longer term. Although this will not be touched any more, everything stated for FEM is also true for BEM.

FEM can be used in solution such problems where the distribution of values of one or more scalar or vector variables depending on space and time should be determined in a domain. In our case the variables are climate characteristics and the domain is the inner space of glasshouse. The examined variables are the solutions of elliptic or parabolic partial differential equations. By means of mathematical transformations the differential equations can be transformed to equivalent functionals or boundary integrals. The most popular numeric method the FEM starts from functionals and the BEM from boundary integrals. The steps of the FEM solution are as follows:

- defining the geometry of examined domain with definitions of subdomain of different properties,
- dividing domain into small subdomains called finite elements (this is automatized in modern programs),
- entering physical coefficients of subdomains (heat conduction, vapour diffusion, air viscosity coefficients, and so on),
- entering boundary conditions (surface and radiation heat transfer, ventilation places and characteristics, material produced by plant, such as carbondioxid, oxygen, vapour),
- operation of computer model (run on computer),
- interpretation and evaluation of computer result.

## MOST IMPORTANT CHARACTERISTICS OF GLASSHOUSE CLIMATE

Environment is most important to living creatures. The basic properties of plants are determined by genes, but physical and chemical features are depending on environment also. For instance as a result of the combined effect of glasshouse light and heat conditions a plant can be taller the fruit sweeter. Every plant species has the most favourable intervals of environment factors. Despite the environment peculiarities depending on geographic site favourable climate characteristics can be obtained in glasshouses or in other completely or partly closed climate chambers. Photosynthesis of plants are primarily influenced by light conditions and the level of carbondioxide content. In order to adjust them and other characteristics it is advantageous to know their characteristic values more precisely and widely. Of course this a matter of measurement.

### *Modelling specialities of glasshouse climate*

The following properties of climate of glasshouse inner space is possible and practicable to be investigated making use of FEM or BEM:

- light conditions,
- temperature distribution and change,
- moisture and vapour distribution and diffusion,
- motion, distribution and diffusion of chemical materials (carbondioxide, oxygen, etc.),

- coupled or simultaneous investigation of the characteristics (two or more of them above considering the mutual interactions).

### **Light conditions**

Radiation to glasshouses is important for two reasons. Above all it makes possible and influence the photosynthesis which determines the development of plants. The other important feature is the effect of radiating heat on changing temperature. Most of light radiation permeably through atmosphere has 290-3000 nm wavelength interval. From this the interval seeable for human eye and stipulating photosynthetic reaction is between 400 and 700 nm wavelength. Permittivity and the inherited energy depends on wavelength. Both light and heat conditions are significantly influenced by the vapour content of glasshouse air, possibility and quantity of vapour condensation on glass walls. In the case of climate controlled spaces there are three different type radiation such as direct, diffusive and artificial origin ones. Their presence and distribution are influenced by obstacles to the radiation such as reflecting, filtering or other way acting objects. Computer modelling of light conditions can be solved by joining geometric or phototechnic properties to finite element modelling. Today the suitable softwares are available already. Geometric and phototechnic modelling of light conditions with taking into account vapour, dust and chemical content of inner space as well as the effects of vapour condensations and other settling can supply characteristic space values, boundary and initial values to FEM, otherwise it can use values as boundary prescriptions supplied by FEM.

Besides the quantity and composition of light radiation changing according to section of day and season the utilized light energy depends on the light permeability, state, carrying structure and orientation of building.

### **Heat conditions**

FEM application makes possible to model time changing temperature distribution of glasshouse inner space. Temperature is the space variable in this case. Transfer of radiating heat, the convectional heat transfer of walls, equipments such as heater or cooler devices, heat brought or taken by air flow, heat storage and supplying capacity of soil, heat consumption and production of plants, building structure heat capacity should be taken into account as boundary and initial conditions. The importance of any characteristic and the neglecting possibilities are the functions of the circumstances of the given problem. The composition and thermal properties of medium filling up the glasshouse changes in time and are in relation with other analyzed variables so that they should be investigated in interaction with them in coupled or simultaneous system.

The original goal of establishing glasshouses were to grow plants in closed space heated by solar radiation heat. The greenhouse is heat collecting and passive heating unit. The incoming short wavelength radiation through transparent material are absorbed by the plants and the soil and they produce long wavelength radiation what can not leave through the transparent walls. This is incorrectly considered glass house effect in spite that this gives only 20% of the total energy. The main glasshouse effect can be assigned to the heat storage capacity of the air in closed space.

Depending on the outer climate glasshouses can require heating or cooling. Thermal properties of such equipments should be taken also into account. The discussed model investigation and simulation can supply significant help first of all to the design, optimization and energy saving operation of these equipments.

As for heating systems, in the case of air heating hot air is transported to the glasshouse through air channel. Design and

location of air channels can be examined by FEM and optimum solution can be produced. The question to answer is to design heating air channels which supply a part of the boundary conditions to make the heat utilization of glasshouse optimal. The question is similar in the case of hot water circulation pipeline and radiator systems. In large complexes there are sometimes steam heating systems, too. In the case of such high operational temperature systems models should account for the larger amount of radiating heat. In this case the air temperature can be lower but the plants could grow slower an less evenly.

In the case of glasshouses cooling systems can also be applied. Among them the modelling procedure of mechanical systems can be similar to that of heating systems. To limit the inner temperature shading and evaporating cooling systems are used. The preceding will change the convectional boundary conditions besides the radiation characteristics. In the case of the latter the thermal properties of the examined domain are changed through the considerable change of air vapour content.

### **Modelling flow properties**

Though among the modelling tasks listed here the heat diffusion can be controlled most closely the flow models influencing temperature distribution greatly can also be applied. In this case the distribution of air velocity and streams are investigated. The main properties of the modelled domain are the flow properties of the given composition air. The boundary conditions are the know air velocity places. Through this first of all the system of ventilation can be modelled and optimized. The ventilation can have more goals, for instance reducing air moisture content, changing inside temperature to the outside level or reducing daytime carbon dioxide content toward outside level.

### **Diffusion modelling**

In the air of glasshouses the water vapour content and the carbon dioxide concentration are of which the distribution is important. Vapour saturation and concentration can be equalized by diffusion. At the finite or boundary element modelling the examined domain attributes are moisture content and concentration values. The properties of domain are given by diffusion coefficient and moisture capacity. Boundary conditions are the vapour condensation (or entering) and carbon dioxide generation (or absorption) values.

### **Coupled and simultaneous modelling**

Characteristics are present and changes concurrently. In simple cases it is enough to examine them independently to each other. In most cases, however, two or more field variables should be handled simultaneously or coupled. So the modelling of a complex system will be formed such a way that the space dependence is only considered with the actual values belonging to the given time and after the solution of the space domain problem time step relationship (usually integration) is used and with the new values the next space solution is used. This steps are repeated until the solution is finished. This procedure rather time and memory consuming on the computers. Nowadays there are fast engineering workstations which can solve these type of problems in acceptable time (a few days CPU time) using finite element method. Boundary element solutions can be achieved in quite shorter time.

The solutions obtained for time and space dependent variables produce a great deal of data to be evaluated and used to select the optimum construction, design and climate control characteristics. Of the latter is also rather sophisticated job. It is also important to apply the relevant and reliable measuring data in the modelling and simulation. It is impossible to solve any problems with computer without measuring data.



## PART III.

# ABBREVIATED TEST REPORTS



## AGRICULTURAL MACHINE TEST

Hungarian Institute of Agricultural Engineering  
FM Műszaki Intézet, 2101 Gödöllő, Tessedik S.u.4

### *VOGEL-NOOT L 950 reversible plough*

Vogel-Noot L 950 reversible plough is made by Vogel u. Noot, Landmaschinenfabrik GmbH, Wartberg, Austria. On corn and cereal stubble field the cutting and loosening work of the plough bodies is satisfactory and the turning down effect is good (90-98 %). The furrow making work of the plough is also good and its stability is inside the prescribed limits. The plough operation needs 40-60 kW power tractor. The operational safety of the plough is satisfactory ( $K_4=0.96$ ). With MTZ-82 tractor it performs about 0.4 ha/h rate in operation. On different hardness soils it is well applicable for producing even surface ploughing (free from furrow and ridge) upto 32 cm working depth.

Main specifications:

Working width	0.7 m
Stocks number	2 x 2 pcs
division	950 mm
working width	350 mm
Frame height	720 mm
Machine mass	430 kg



Manufacturer: Vogel u. Noot, Wartberg, Austria and VN  
Agricultural Machine Factory Ltd. Mosonmagyóvár  
Test No.: 574

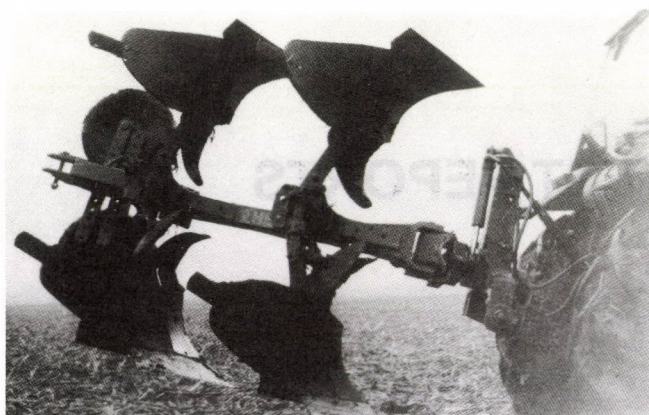

### *EIGER 90 HM reversible plough*

EIGER 90 HM reversible plough is made by Gasselich Maschinenfabrik, Mistelbach, Austria. The plough bottoms mounted with disk breast (turning down disk) revolves perfectly either on cereal or corn stubble fields. Mellowing changed between 85 and 95 %. The furrow making work of the plough is good, its stability is between prescribed limit values. The plough operation needs 40-60 kW power tractor. The operational safety of the plough is excellent ( $K_4=1.00$ ). With MTZ-82 tractor it performs about 0.4 ha/h rate in operation. On different hardness soils it is well applicable for producing even surface ploughing (free from furrow and ridge) upto 32 cm working depth.

Main specifications:

Working width	0.66 m
Stocks number	2 x 2 pcs
division	810 mm
working width	330 mm
Frame height	710 mm
Machine mass	400 kg

Manufacturer: Gasselich Maschinenfabrik, Mistelbach, Austria  
Test No.: 575

### *JUKO MAXI RX potato harvester*

JUKO Maxi RX towed potato harvester machine is made by OY JUKO Ltd. in Finland. The machine is applicable to dig out single row potato, to clean it from soil contaminations and stem remains. With 2 to 4 handling crew it is also applicable for final cleaning and discharging into 3 m<sup>3</sup> collecting container and into transport vehicle. The working speed of machine is 2-4 km/h the area rate is 30 to 50 ha in a season. The characteristic values are 1-2 % harvest loss, 2-4 % tuber damage, 96-99 % produce cleanness and 0.16-0.18 ha/h area rate while the productive time. The operation needs 50-60 kW power tractor with 6 ribs 540 rpm power shaft.

Main specifications:

Working width	0,75 m
Number of rows	1
Container volume	3,0 m <sup>3</sup>
Manipulating crew	2-4 persons

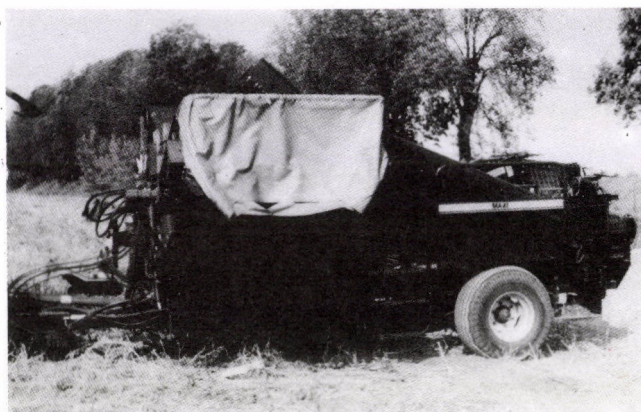

Manufacturer: OY JUKO Ltd, Mynämäki as Finland  
Test No.: 580

## *M-5610 spinning disk fertilizer broadcaster*

M-5610 rotating disk artificial fertilizer spreader is made by MEZŐGÉP RT, Szolnok in Hungary. The implement of 0.8 m<sup>3</sup> container volume mounted with two spinning disks is applicable to broadcast 20-350 kg/ha doses of different type fertilizers with 20 to 24 working width. The operational safety of its good. The energy consumption and the spreading quality are favourable. The machine is sensitive to the fertilizer quality. The suspended machine can be operated safely with MTZ-80 tractor mounted with a minimum 500 kg overweight.

**Main specifications:**

Outer sizes	length	1250 mm
	width	1150 mm
Container volume (changeable)		0.8; 1.0; 1.3; 1.5 m <sup>3</sup>
Working width of machine (depending on fertilizer type)		20-26 m
The spreadable amount of fertilizer		30-350 kg
Machine mass		295 kg



Manufacturer: MEZŐGÉP RT, Szolnok  
Test No.: 578



Manufacturer: PANNON PATENT Ltd., Pécs, Hungary  
Test No.: 586

## *HSP 25 hl/week capacity brewery*

HSP type apparatus was developed by the Pécs PANNON PATENT Ltd. as the base machine to the 500 litre/day (25 hectolitre/week) capacity beer plant of cold maturation technology. The plant consists of a brewer house, fermenting containers and additional technology equipments. In complex examination of equipments we found that the technology line produces 500 litre 12.3 degree PILS type light beer within 11 hours. The electricity need of brewery is 105 kWh. The ice accumulator cooler has a heat drawoff capacity of 8.4 kW. The ice accumulator cooler tend to operate unstable in period of keeping cold and then the evaporator can freeze up. The bins and vessels meet hygiene demands. The apparatuses obliged to get working safety examinations are appropriate and well meet the healthy and safe working conditions.

**Main specifications:**

Daily output	500 litre/day
Brewing bin volume	1000 litre
Fermenting bin volume	600 litre

## *KERTITOX FARMER F-600/12 sprayer machine*

KERTITOX FARMER FSZ-600/12, suspended, cardan shaft driven spraying machine is made by FARMGÉP Ltd., Debrecen, Hungary. Sprayer heads have 15.5-32.8 cm<sup>3</sup>/s spraying rate in 0.2-0.4 MPa pressure range. The alterations in the spreading evenness meet the figures of agrotechnical requirements. The cross directional spreading evenness with KORUM F-3, F-4 spraying head insertions was satisfactory. Covering density tests showed the working quality of machine good. The area rate is around 3.4 ha/h. Operating tractor need is a mean power (22-37 kW) one. The classification of the implement is "good".

**Main specifications:**

Container volume	600 litre
Working width	12 m
Pump transport rate	120 litre/min
Machine mass	350 kg



Manufacturer: FARMGÉP Ltd., Debrecen, Hungary  
Test No.: 581



## AGRICULTURAL MACHINE TEST

Hungarian Institute of Agricultural Engineering  
FM Műszaki Intézet, 2101 Gödöllő, Tessedik S.u.4

### *BF-01 potato and root vegetable lifter*

BF-01 single row potato lifter is made by MAGÉP, Agricultural Machine Producing Company, Makó in Hungary. The loss of machine in potato is below 0.5 % in potato at 1.3 km/h working speed. The damage caused by the machine is about 3.4 %. Operated with MTZ-82 tractor the rate is 0.09 ha/h on the term of base time. The operation safety is satisfactory. The lifter is well applicable on sandy or moderately hard soil, to dig out, preclean and to put down potatoes planted in 70-75 cm row distance. The classification of the machine is "satisfactory".

#### Main specifications:

Working width		0.75 m
Number of harvested rows		1
Outer sizes	length	3400 mm
	width	1050 mm
	height	1100 mm

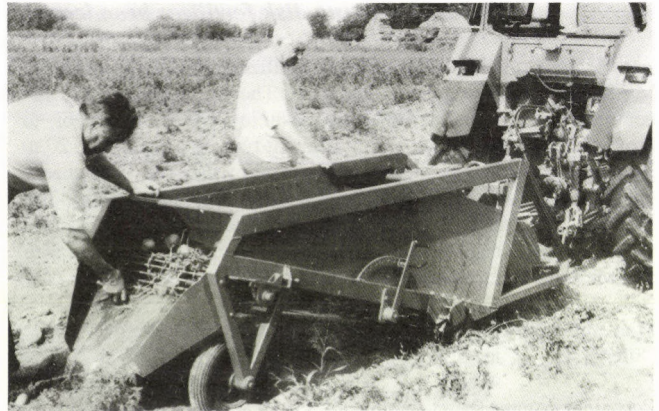

Manufacturer: MAGÉP, Agricultural Machine Producing Company, Makó  
Test No.: 579

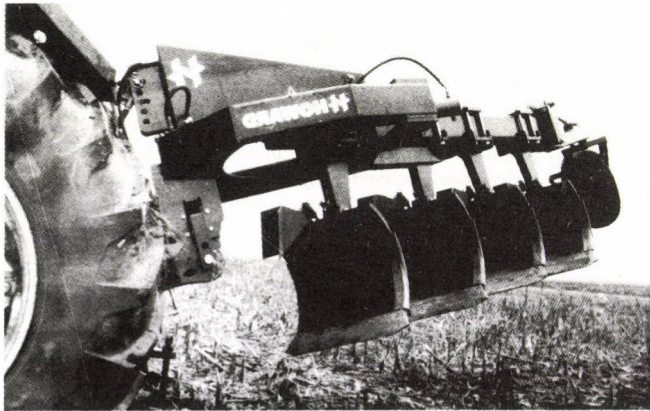

### *HOWARD SP 4 reversible plough*

HOWARD SP 4 reversible plough is made by HOWARD Maschinenfabrik GmbH, Michelstadt, Germany. Examinations completed on cereal stubble fields showed that the mellowing and turning works of the plough are excellent. The furrow making work and the stability of the plough is good. On corn stubble field the even working depth and the continuous operation can be hold only in favorable circumstances. The plough operation needs 80-110 kW power tractor. The operational safety of the plough is excellent ( $K_4=0.99$ ). With FIAT-1880 DT tractor it performs about 1.1 ha/h rate in operation. The plough is suitable for ploughing loose and moderately hard soils covered with plant remains in small or medium extent (maximum 6 ton/ha) upto 32 cm working depth.

#### Main specifications:

Working width	1.8 m
Stocks number	4 pcs
division	710 mm
working width	450 mm
Frame height	870 mm
Machine mass	1165 kg

Manufacturer: HOWARD Maschinenfabrik GmbH, Michelstadt, Germany  
Test No.: 576

### *KERTITOX TIFONE 2000 plantation sprayer machine*

KERTITOX 2000 sprayer machine is made for grape and fruit plantations by FARMGÉP Ltd., Debrecen, Hungary. Sprayer heads have 1.99-8.41 dm<sup>3</sup>/min spraying rate in 1.0-3.0 MPa pressure range. The alterations in the spreading evenness meet the figures of agrotechnical requirements. The air transport rate of the axial ventilator is between 28000 and 65000 m<sup>3</sup>/h. The machine in working quality examinations exposed good mizzle distribution on the basis covering density and front to back density ratio (1.09-1.5) values. The area rate is around 2.42 ha/h. The classification of the implement is "good".

#### Main specifications:

Container volume	2000 litre
Pump transport rate	150 litre/min
Axial ventilator air transport rate	28000-65000 m <sup>3</sup> /min
Number of transport heads	16 pcs



Manufacturer: FARMGÉP Ltd., Debrecen, Hungary  
Test No.: 582



## AGRICULTURAL MACHINE TEST

Hungarian Institute of Agricultural Engineering  
FM Műszaki Intézet, 2101 Gödöllő, Tessedik S.u.4

### LECHLER spraying heads

STANDARD 11002, 11004 and LU 120-02, LU 120-04 and AD 120-02 spraying head insertions were involved in the investigations. In the examinations the spraying rate, feeding evenness and cross directional evenness were found as meeting well the agrotechnical demands. The deviations from the mean values are below the allowed limits. Insertions tested are appropriate for good quality arable land plant protecting works. Classification is "excellent".

#### Main specifications:

Operational pressure	0.15-0.45 MPa
Spraying rate	0.55-1.8 litre/min
Drop size	

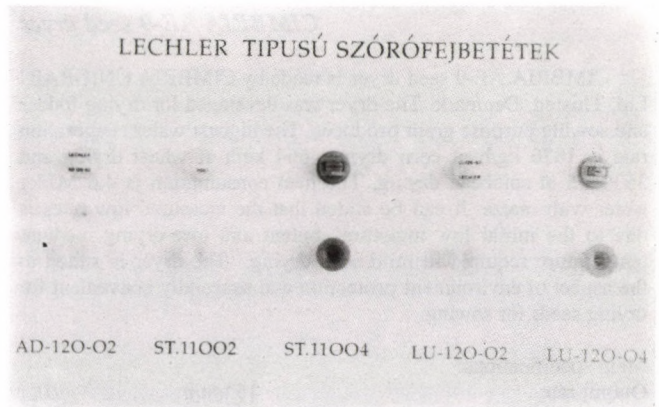

Manufacturer: LECHLER GmbH, Fellback, Germany  
Test No.: 583



Manufacturer: AGRIKON, KMG, Kecskemét  
Test No.: 577

### FNR-3 combined heavy cultivator

FNR-3 combined heavy cultivator is made by AGRIKON, KMG, Kecskemét. The wing type bottoms carry out complete loosening. The star-shaped wheels and the cylinder harrow produce good smoothing and mellowing effect. Functional test carried out on ploughed up pea, sunflower and spring barley stubbles verified the many-sidedness of the machine. The cultivator operation needs 100-120 kW power tractor. The operational safety of the machine is good ( $K_4=0.98$ ). With FIAT-1880 DT tractor it performs about 1.8 ha/h rate in operation. It is well applicable to cultivate different hardness soils without turning, to plough up stubbles, for soil tending and seed bed preparation.

#### Main specifications:

Working width	3.0 m
Hoes number	7 pcs
division	425 mm
Star shaped wheels	8 pcs
division	230/360 mm
diameter	650 mm
Cylinder harrow diameter	500 mm
Machine mass	1165 kg

### FVA-2 greenhouse ventilation control

FVA-2 foil house ventilation control automaton is made by NAYAN ELEKTRONIKA, Szentes. The device is applicable to control ventilation in greenhouses mounted with electrically operated remote control ventilation windows. It also controls heater, motor or magnetic operated valves of thermal water heating and alarm signal. The device measures the temperature in 5 to 20 Centigrade range with an error of  $\pm 1.1-0.0$  °C. The temperature measuring is delayed so that the sudden temperature changes would result in operation troubles. With the wind sensor the storm indication value can be well adjusted. The classification of device is "good".

#### Main specifications:

Control range	10-30 Centigrade
Cycle time	1-10 min
Operation time	1-10 min
Power supply	220 Voltage, 50 Hz

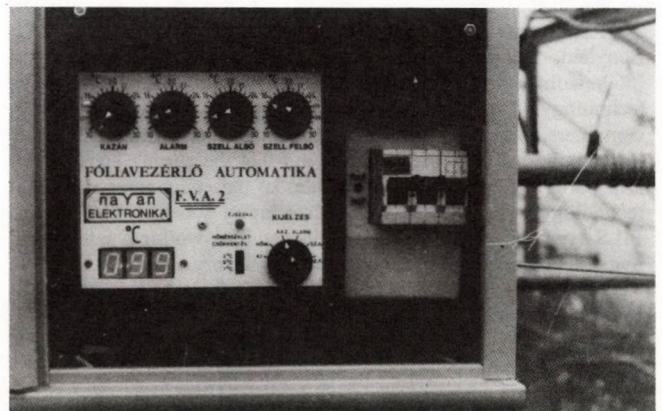

Manufacturer: NAYAN ELEKTRONIKA, Szentes, Hungary  
Test No.: 584



## AGRICULTURAL MACHINE TEST

Hungarian Institute of Agricultural Engineering  
FM Műszaki Intézet, 2101 Gödöllő, Tessedik S.u.4

### *CIMBRIA AE-9 seed dryer*

CIMBRIA AE-9 seed dryer is made by CIMBRIA UNIGRAIN Ltd, Thisted, Denmark. The dryer was developed for drying fodder and sowing purpose grain produces. The highest water evaporation rate is 1870 kg/h at corn drying, 664 kg/h at wheat drying and 353 kg/h at sojabean drying. The heat consumption is 4.6 MJ/kg water with maize. It can be stated that the measured low rates is due to the initial low moisture content and low drying medium temperature required in mild seed drying. The dryer is suited to the aspect of environment protection and especially convenient for drying seeds for sowing.

**Main specifications:**

Output rate	15 ton/h
Water evaporator rate	1870 kg/h
Built-in electric power	955 kW

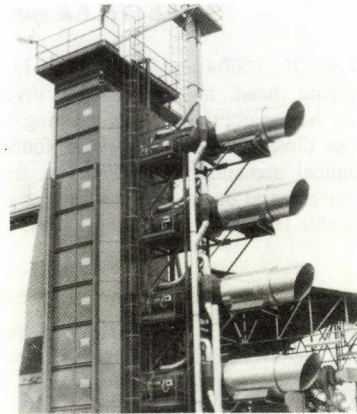

Manufacturer: CIMBRIA UNIGRAIN Ltd, Thisted, Denmark  
Test No.: 585

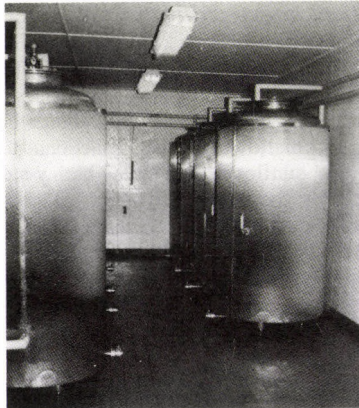

Manufacturer: EUROPA Ltd., Budapest, Hungary  
Test No.: 587

### *BLONDER 40 hl/week capacity brewery*

BLONDER type brewery apparatus are sold by the EUROPA Ltd., Budapest, Hungary. It was developed as the base machine to a 800 litre/day (40 hectolitre/week) capacity beer plant of cold maturation technology. The bins and vessels in contact with the beer are made of stainless steel. In the course of operation, working safety, and hygiene control examinations the storing capacities and the measured output rate data of part units meet well the technology. With the line 800 litre brewed beer can be made within 8 hours. The brewery is convenient for producing 12.3 degree PILS type filtered light beer with 40 hl/week output rate. The apparatuses obliged to get working safety examinations are appropriate and well meet the healthy and safe working conditions.

**Main specifications:**

Daily output	800 litre/day
Brewing bin volume	1200 litre
Fermenting bin volume	1000 litre

### *KARL 56 hl/week capacity brewery*

KARL type brewery apparatus is turning over by BOGÉP Ltd., Bonyhád, Hungary as the base machine to the 800 litre/day (56 hectolitre/week) capacity beer plant of cold maturation technology. The plant consists of a brewer house, fermenting containers, heating, technology equipments and fittings. In the examination of equipments we found that the storing capacity of unit parts, the measured output rates of the equipments meet the technology well. The technology line brews 800 litre 12.3 degree PILS type light beer within 10 hours. The working safety and hygiene classification of the plant is satisfactory.

**Main specifications:**

Daily output	800 litre/day
Brewing bin volume	1000 litre
Fermenting bin volume	900 litre

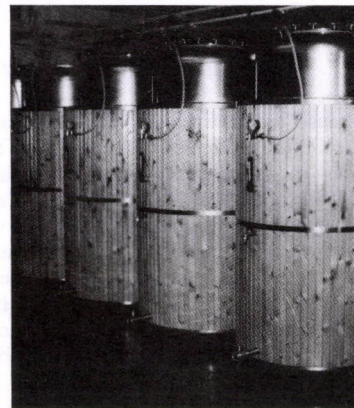

Manufacturer: BOGÉP Ltd., Bonyhád, Hungary  
Test No.: 588

**Contents of the  
"Mezőgazdasági Technika"  
periodical of the year 1993.**

**MEZŐGAZDASÁGI  
TECHNIKA**  
2100 GÖDÖLLŐ, TESSEDIK S.U.4.

**Nº 1.**

Agricultural-technical expert consult (J. Hajdú) .....	Cover II.
John Deere machines on the KSZE market (Z. Somogyi - L. Szűcs) .....	1
Perspectives of bio-fuels in the country (K. Nagy) .....	4
Small farms on sloping area (S. Tóth) .....	6
Features of business planing in the case of technical enterprises (I. Husti) .....	7
Page of lease holders .....	11
Applicators of solid fertilizers (Gy. Demes) .....	15

**Nº 2.**

Task of the industry in the transforming agriculture (I. Szabó) .....	1
Possibilities of production of the renewing energy carriers (K. Kocsis) .....	4
Horticultural drills (J. Buzás - P. Nádas) .....	15
Automatic milking, feeding (L. Tóth - J. Bak - T. Liptay) .....	20
Experiences of enterprise extension service Szabolcs-Szatmár-Bereg county (L. Papp - Á. Marton) .....	24
For gentle tobacco drying (K. Benedek - A. Lengyel - L. Fenyvesi) .....	29
Australian agricultural machines and methods .....	32

**Nº 3.**

Recognizing on the scientific conference of the MTA-AMB .....	1
Retrospect - 80 years ago the plough machine demonstration was held in Galánta .....	2
Draft of award for agricultural machines in England .....	3
Tight-ring bearings in the agricultural machines .....	4
Difficulties of change of regime in the Russian agriculture .....	6
The Impulsa renews .....	20
The viscosity clutch .....	24
Electronic wheel-adhesion control .....	26
The Hungarian energy policy and the local governments .....	29

**Nº 4.**

Significance of soil conservation in the surface cultivation (M. Birkás) .....	2
Efficiency of seed processing .....	4
Taurus agricultural tyre .....	7
The industrial use - biggest hope .....	13
New small farm machines .....	19
Mountable turbo-charger at a later time .....	21
Inner air-filter .....	24
New series - new machines .....	28

**Nº 5.**

The transforming agricultural branch and the machine requirement (A. Sziráki) .....	2
Individual and collective enterprises based on private ownership (J. Nagy) .....	4
Stabilization of the agrarian world (I. Kőrösi) .....	5
Mowers (Zs. Kelemen) .....	15
Information for renting entrepreneurs (L. Tóth) .....	27
Report of the General Assembly of MEGOSZ .....	32

**Nº 6.**

New tractor generation from the John Deere (I. Fodor) .....	2
What was seen at the AGRO+MASHEXPO (J. Hajdú) .....	4
Windrow handling machines (Zs. Kelemen) .....	15
Machines and equipment for animal keeping (L. Tóth) .....	24
Filtering and lubricating oil .....	28
Novelties from the Massey Ferguson .....	29
The Vogel-Noot plough factory is in production (J. Sebestyén) .....	31

**Nº 7.**

FAO Conference (Gy. Mészáros) .....	Cover II.
Experiences about the Vogel-Noot reversible plough (S. Soós) .....	2
Intelligent fire alarm system for driers (Gy. Vargha) .....	4
Measuring of heating oil consumption of driers .....	5
Drier from Bábolna elements (L. Fülöp) .....	6
Technical - technological Day at the KSZE (J. Sebestyén) .....	7
Electrophysical method for seed cleaning (P. Szendrő - J. Koltay - Gy. Vincze) .....	24
Spectacular Machine show at Zagyvarékas .....	28

**Nº 8.**

Agricultural utilization of Rovatti pump (Gy. Vargha) .....	2
We are waiting for the next (E. Dul Udó) .....	4
Agricultural Engineering Days at Gödöllő (J. Hajdú) .....	6
Grain cleaning and it's equipments (J. Csermely - M. Herdovics) .....	15
The technical background of irrigation is also important (L. Lelkes - A. Cserhidy) .....	26
The Hungarian Tillage Society has been founded (M. Birkás) .....	29
The new "Z" series John Deer combine harvesters are working (J. Juhász) .....	30

**Nº 9.**

Choice of tillage implements and the quality of summer soil tillage (M. Birkás) .....	2
Claas harvesters "Made in Germany" .....	5
Potato harvesters (J. Füzy) .....	15
Agricultural undertaking in rent basis in Netherlands (L. Tóth) .....	26
The results of the new "Z" serial John Deere harvesters .....	28
What does the powershift transmission know (M. Szente - G. Radványi) .....	30

**Nº 10.**

Change of technical provision of the agriculture during the transformation (J. Hajdú) .....	2
The most newly-developed small machines of VALMONT in the irrigation (J. Szendi) .....	4
By-effects occurred in course of operation of high output irrigation equipment (A. Cserhidy - J. Lelkes) .....	6
For margin of an exhibition (L. Tóth) .....	7
Reversible ploughs (I. Jóri J.) .....	15
What to know about the dressing (J. Huszár) .....	26

**Nº 11.**

European Ploughing Championship – Bruck (S. Soós) .....	Cover II.
The effect of field size on the costs of machine operation (L. Gockler) .....	2
Novelties at the 2nd International Farmer Days of Bábolna (J. Széles) .....	4
Storing equipment for grain crops (Gy. Komka) .....	15
Exhibition at Bábolna (J. Hajdú) .....	25

**Nº 12.**

Soil tillage demonstration in Great Britain (M. Birkás) .....	Cover II.
Agricultural Mechanization Conference in Korea (Gy. Mészáros - L. Tóth) .....	4
Extension service – with technical content (Husti István) .....	6
Cattle self-drinkers (L. Tóth - J. Bak - J. Bolyós) .....	15
Aeration and heating control in greenhouse (F. Jakovác - J. Buzás) .....	22
International Claas-Forum (J. Sebestyén) .....	24
Development of a compost maker (J. Kosztyu) .....	30

*Do you want to know more from*  
**Hungarian Agriculture Machinery!**

**SENDTMIS ORDER FORM TO:**  
 The Hungarian Agricultural Machinery Journal  
 H-2101 Gödöllő, Tessedik S.u.4. - Hungary

**ORDER FORM**

I want to order the Hungarian Agricultural Machinery Journal  
 from ..... day ..... month 199.....

The subscription fee: 1980 HUF

Name: .....

Address: .....

Code: ..... City: .....

Country: .....

Date: ..... day ..... month 199.....

.....  
 signature

## CONTENTS

### PART I

ABSTRACTS OF SELECTED PAPERS .....	5
------------------------------------	---

### PART II

SELECTED SCIENTIFIC PAPERS .....	11
----------------------------------	----

#### POSSIBILITIES OF PRODUCING RENEWABLE ENERGY RESOURCES IN THE AGRICULTURAL ECONOMY

Dr. K. KOCSIS University of Agricultural Sciences, Gödöllő .....	12
---	----

#### METHOD FOR PLANNING THE UTILIZATION OF MANURE IN ENVIRONMENTAL FRIENDLY MANNER

GY. MÉSZÁROS - Dr. L. FENYVESI - L. MÁTYÁS - Dr. B. KULI - P. HORINKA Hungarian Institute of Agricultural Engineering, Gödöllő .....	15
--	----

#### ELABORATION OF AN ELECTROPHYSICAL PROCEDURE FOR SEED CLEANING

Dr. P. SZENDRŐ - Dr. J. KOLTAY - Dr. GY. VINCZE University of Agricultural Sciences, Gödöllő .....	17
---	----

#### SOIL PHYSICAL AND TILLAGE ENERGETIC INTERACTIONS

Dr. B. SINÓROS-SZABÓ - Dr. B. KAZÓ University of Agricultural Sciences, Agricultural Engineering College, Nyíregyháza .....	20
---	----

#### PIG HUSBANDRY ON DEEP LITTER

L. MÁTYÁS - Dr. B. KULI Hungarian Institute of Agricultural Engineering, Gödöllő Dr. G. MÁRAY - E. GYÖKÖS PÁLVÖLGYINÉ University of Agricultural Sciences, Gödöllő .....	23
---	----

#### AUTOMATIZATION OF MILKING DEVICE CLEANING PROCESS

Dr. L. TÓTH - Dr. J. BAK - J. BOLYÓS Hungarian Institute of Agricultural Engineering, Gödöllő .....	25
--	----

#### COMPARATIVE TEST WITH DIFFERENT BIO-DIESEL FUELS IN TRACTOR ENGINE

Dr. I. J. JÓRI - Dr. M. SZENTE - G. RADVÁNYI Hungarian Institute of Agricultural Engineering, Gödöllő .....	27
--	----

#### DRUM CAGE SUPPORT FORCES AND THE DRIVING FORCE OF DRUM

Dr. P. SOÓS - Dr. ZS. SZÜLE - Dr. J. KOLTAY - Dr. K. PETRÓCZKY University of Agricultural Sciences, Gödöllő .....	29
---	----

#### APPLICATION OF THERMOGRAPHY IN AGRICULTURAL ENGINEERING RESEARCH

Z. PAPP Hungarian Institute of Agricultural Engineering, Gödöllő .....	31
---	----

#### EXAMINATION OF GRAIN MILL FOR SMALL SCALE FARM

Dr. GY. GYÖRFY University of Agricultural Sciences, Agricultural Engineering College, Mezőtúr .....	33
---	----

#### THERMOVISION METHOD FOR THE MEASURING OF THE KERNEL'S SURFACE TEMPERATURE DURING DRYING

M. NEMÉNYI - K. KACZ - I. CZABA - A. KOVÁCS PANNON Agricultural University, Mosonmagyaróvár .....	35
--	----

#### ENGINEERING AND ENVIRONMENT PROTECTION QUESTIONS OF VEGETABLE ENGINE FUELS

Dr. A. VAS - Dr. V. VARGA University of Agricultural Sciences, Gödöllő .....	37
---	----

#### MATHEMATICAL MODEL OF MASS REDUCING OF TILLAGE MACHINES

Dr. I. PÁLINKÁS University of Agricultural Sciences, Gödöllő .....	39
---	----

#### OPERATION EXPERIENCES OF DAIRY COW PLANTS SUPPLIED WITH COMPUTER PRODUCTION MANAGEMENT SYSTEM

Dr. A. ERÉNYI University of Agricultural Sciences, Agricultural Engineering College, Mezőtúr .....	41
--	----

#### ANALYSIS MEASURING ERRORS OF MEASURING CIRCUIT BUILT WITH THERMOCOUPLE

Dr. GY. VINCZE - I. SERES University of Agricultural Sciences, Gödöllő .....	42
---	----

#### ROUTE PLANNING ON TRANSPORT NETWORK

Dr. J. BENKŐ University of Agricultural Sciences, Gödöllő .....	45
--	----

#### A SYNTHESIS OF THE INTER-RELATIONS ANIMAL HOUSE, ENVIRONMENT, RENTABILITY, HUMAN AND ANIMAL WELFARE

Dr. A. MATON RvL, Merelbeke, Belgium .....	46
---	----

#### HEAT- AND MATERIAL TRANSPORT PROCESS IN DRYING OF SEED PEAS

Dr. J. CSERMELY - Dr. Z. BELLUS - Dr. M. HERDOVICS - GY. KOMKA Hungarian Institute of Agricultural Engineering, Gödöllő .....	48
---	----

#### NON-DESTRUCTIVE METHOD OF FRUIT ELASTICITY DETERMINATION

Dr. A. FEKETE University of Horticulture and Food Industry, Budapest .....	50
---	----

#### WARMING UP OF BARLEY GRITS IN HAMMER-MILL (OTKA)

Dr. I. BÖLÖNI - Dr. J. CSERMELY - S. SALAMON Hungarian Institute of Agricultural Engineering, Gödöllő .....	53
--	----

#### APPLICATION POSSIBILITIES OF SOLAR AND WIND ENERGIES IN THE ENTERPRENEURIAL ANIMAL FARMING

Dr. L. TÓTH - Dr. J. BAK - P. PECZNIK Hungarian Institute of Agricultural Engineering, Gödöllő .....	55
---	----

#### INTENSIVE MIXING THE CEREAL BULKS BY PNEUMATIC METHOD DURING STORAGE

Dr. K. KACZ - Z. SÁRKÁNY PANNON Agricultural University, Mosonmagyaróvár .....	57
---	----

#### QUALITY CONTROL OF BIOBRIQUETTES AND EXPERIENCES WITH THEIR COMBUSTION

P. PECZNIK - GY. VARGA Hungarian Institute of Agricultural Engineering, Gödöllő .....	59
--	----

#### APPLICATION POSSIBILITIES OF FINITE AND BOUNDARY ELEMENT METHODS IN CLIMATE CONTROL DESIGN OF GREENHOUSES

Dr. F. KASZA University of Agricultural Sciences, Gödöllő .....	61
--	----

### PART III

ABBREVAITED TEST REPORTS .....	63
--------------------------------	----

Introduction 1

1. The Role of the State in Economic Development 3

2. The Role of the State in Economic Development 5

3. The Role of the State in Economic Development 7

4. The Role of the State in Economic Development 9

5. The Role of the State in Economic Development 11

6. The Role of the State in Economic Development 13

7. The Role of the State in Economic Development 15

8. The Role of the State in Economic Development 17

9. The Role of the State in Economic Development 19

10. The Role of the State in Economic Development 21

11. The Role of the State in Economic Development 23

12. The Role of the State in Economic Development 25

13. The Role of the State in Economic Development 27

14. The Role of the State in Economic Development 29

15. The Role of the State in Economic Development 31

16. The Role of the State in Economic Development 33

17. The Role of the State in Economic Development 35

18. The Role of the State in Economic Development 37

19. The Role of the State in Economic Development 39

20. The Role of the State in Economic Development 41

21. The Role of the State in Economic Development 43

22. The Role of the State in Economic Development 45

23. The Role of the State in Economic Development 47

24. The Role of the State in Economic Development 49

25. The Role of the State in Economic Development 51

26. The Role of the State in Economic Development 53

27. The Role of the State in Economic Development 55

28. The Role of the State in Economic Development 57

29. The Role of the State in Economic Development 59

30. The Role of the State in Economic Development 61

31. The Role of the State in Economic Development 63

32. The Role of the State in Economic Development 65

33. The Role of the State in Economic Development 67

34. The Role of the State in Economic Development 69

35. The Role of the State in Economic Development 71

36. The Role of the State in Economic Development 73

37. The Role of the State in Economic Development 75

38. The Role of the State in Economic Development 77

39. The Role of the State in Economic Development 79

40. The Role of the State in Economic Development 81

