

HUNGARIAN

AGRICULTURAL

ENGINEERING

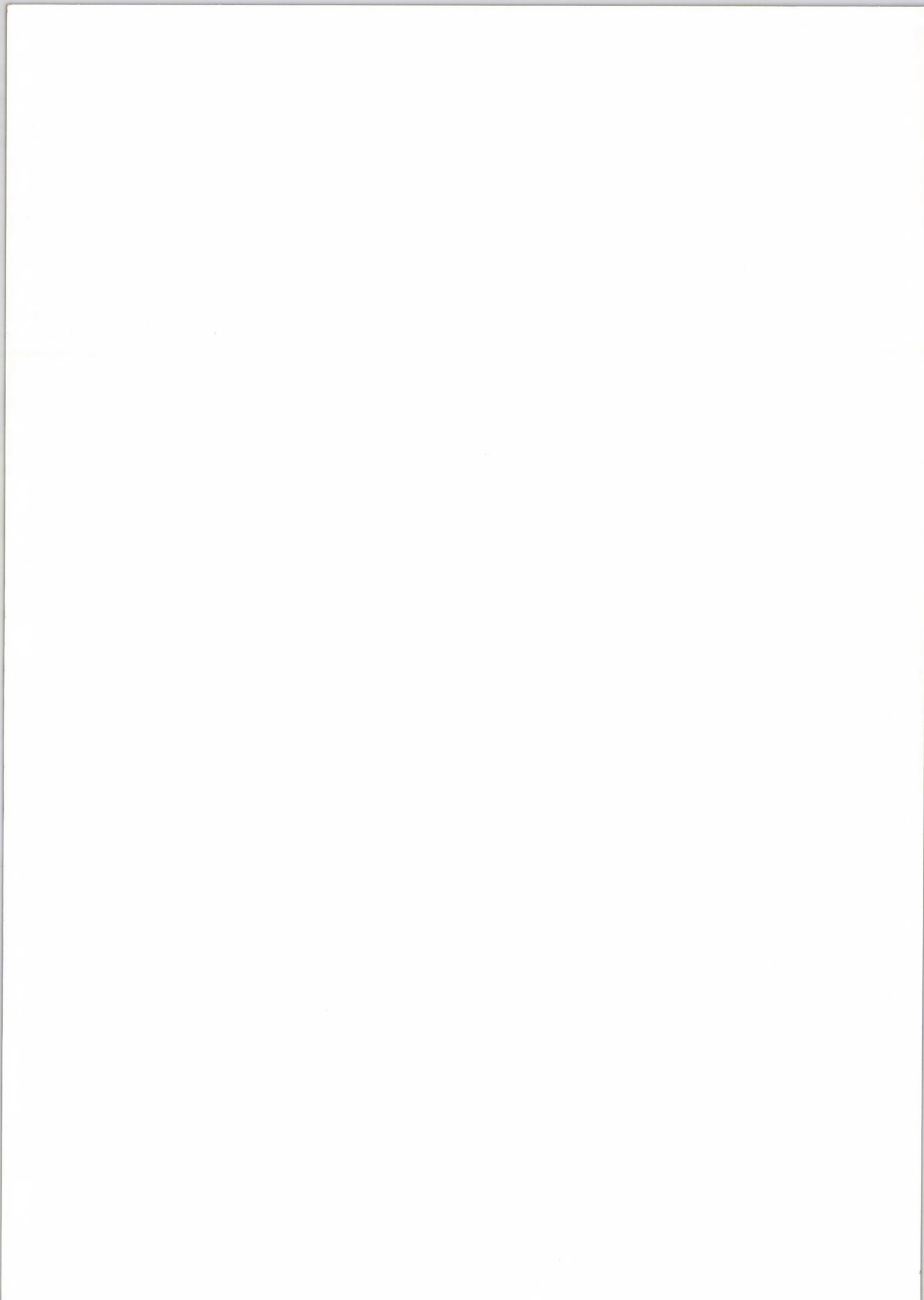



HUNGARIAN AGRICULTURAL ENGINEERING

Periodical of
the Committee of Agricultural Engineering of
the
Hungarian Academy of Sciences

N° 9/1996

Editor:
Prof. Dr. László TÓTH

Editor in Chief:
Dr. József HAJDÚ

Editorial Board:

Dr. Jenő CSERMELY	Dr. Péter SEMBERY
Dr. Imre DIMÉNY	Dr. László TÓTH
Dr. István J. JÓRI	Dr. Attila VAS
Dr. István TAKÁCS	Dr. József HAJDÚ

Published by

Hungarian Institute of Agricultural Engineering
H-2101 Gödöllő, Tessedik S.u.4.

Gödöllő, 1996

HUNGARIAN AGRICULTURAL ENGINEERING

Periodical of

the Committee of Agricultural Engineering of
the
Hungarian Academy of Sciences

No. 2/1958

1958

Volume 10, No. 2

1958

1958

1958

- Dr. János Borkovits, Dr. László Borkovits
- Dr. Imre János, Dr. László János
- Dr. József Horváth, Dr. Árpád Horváth
- Dr. János Takács, Dr. László Takács

Published by

Hungarian Institute of Agricultural Engineering

H-2101 Gödöllő, Tessedik S. u. 4.

HU ISSN 0864-7410

PREFACE

The Agricultural Engineering Board of the Hungarian Academy of Sciences which supervises the development of this branch organises annually a conference at Gödöllő, which is the central place of the Hungarian agricultural scientific activity.

During the sessions, research scientist, developing engineers, experts of institutions engaged in agricultural engineering development strong in numbers the organizer, the hungarian universities and other higher grades of education, the research institutions: Hungarian Institute of Agricultural Engineering at Gödöllő, Faculty of Agricultural Engineering of the University of Agriculture at Gödöllő and foreign guests give account of their results obtained in the research work and development of agricultural machinery.

This yearly English-Language publication the „Hungarian Agricultural Engineering”, started at 1988, contains selected papers presented at the conference of 1996. We do hope that this publication will be found interesting to a big part of agricultural engineers.



Dr. József Hajdú
Director

Hungarian Institute of Agricultural Engineering
Gödöllő

ENERGETIC AND WORK QUALITY
INVESTIGATION OF MAIZE STALK CHAFFING
WITH ALONG-STALK DIGESTING

A. SERRANO, J. BENSE - 1982

Investigación Agrícola, Universidad de Chile

The investigation about the energetic and work quality of maize stalk chaffing is a project of the National Institute of Agricultural Research (INIA) and the Chilean Government. The purpose of this study was to determine the energetic and work quality of maize stalk chaffing with along-stalk digesting. The study was conducted in the experimental station of INIA, Valdivia, Chile, during the years 1979 and 1980. The results of the study are presented in this paper.

The results of the study show that the energetic and work quality of maize stalk chaffing with along-stalk digesting is significantly higher than that of the control. This is due to the fact that the along-stalk digesting process increases the surface area of the stalk, which allows for a more efficient digestion process.

The study also shows that the energetic and work quality of maize stalk chaffing with along-stalk digesting is significantly higher than that of the control. This is due to the fact that the along-stalk digesting process increases the surface area of the stalk, which allows for a more efficient digestion process.

The study also shows that the energetic and work quality of maize stalk chaffing with along-stalk digesting is significantly higher than that of the control. This is due to the fact that the along-stalk digesting process increases the surface area of the stalk, which allows for a more efficient digestion process.

The study also shows that the energetic and work quality of maize stalk chaffing with along-stalk digesting is significantly higher than that of the control. This is due to the fact that the along-stalk digesting process increases the surface area of the stalk, which allows for a more efficient digestion process.

The study also shows that the energetic and work quality of maize stalk chaffing with along-stalk digesting is significantly higher than that of the control. This is due to the fact that the along-stalk digesting process increases the surface area of the stalk, which allows for a more efficient digestion process.

The study also shows that the energetic and work quality of maize stalk chaffing with along-stalk digesting is significantly higher than that of the control. This is due to the fact that the along-stalk digesting process increases the surface area of the stalk, which allows for a more efficient digestion process.

The study also shows that the energetic and work quality of maize stalk chaffing with along-stalk digesting is significantly higher than that of the control. This is due to the fact that the along-stalk digesting process increases the surface area of the stalk, which allows for a more efficient digestion process.

The study also shows that the energetic and work quality of maize stalk chaffing with along-stalk digesting is significantly higher than that of the control. This is due to the fact that the along-stalk digesting process increases the surface area of the stalk, which allows for a more efficient digestion process.

The study also shows that the energetic and work quality of maize stalk chaffing with along-stalk digesting is significantly higher than that of the control. This is due to the fact that the along-stalk digesting process increases the surface area of the stalk, which allows for a more efficient digestion process.

The study also shows that the energetic and work quality of maize stalk chaffing with along-stalk digesting is significantly higher than that of the control. This is due to the fact that the along-stalk digesting process increases the surface area of the stalk, which allows for a more efficient digestion process.

The study also shows that the energetic and work quality of maize stalk chaffing with along-stalk digesting is significantly higher than that of the control. This is due to the fact that the along-stalk digesting process increases the surface area of the stalk, which allows for a more efficient digestion process.

The study also shows that the energetic and work quality of maize stalk chaffing with along-stalk digesting is significantly higher than that of the control. This is due to the fact that the along-stalk digesting process increases the surface area of the stalk, which allows for a more efficient digestion process.

The study also shows that the energetic and work quality of maize stalk chaffing with along-stalk digesting is significantly higher than that of the control. This is due to the fact that the along-stalk digesting process increases the surface area of the stalk, which allows for a more efficient digestion process.

The study also shows that the energetic and work quality of maize stalk chaffing with along-stalk digesting is significantly higher than that of the control. This is due to the fact that the along-stalk digesting process increases the surface area of the stalk, which allows for a more efficient digestion process.

PART I.

ABSTRACT OF SELECTED PAPERS

BEST PRACTICES IN THE PRODUCTION OF THE
EXPERIMENTAL PLOTS

The production of experimental plots is a critical step in the research process. It involves the selection of the best practices for the production of the plots, which are then used to conduct the experiment. This paper discusses the best practices for the production of experimental plots, including the selection of the best practices, the preparation of the plots, and the maintenance of the plots.

ANALYSIS OF MAIZE STALK CHAFFING
AND A STUDY OF THE EFFECTS OF
STALK CHAFFING

The analysis of maize stalk chaffing and a study of the effects of stalk chaffing are two important aspects of the research. The analysis of maize stalk chaffing involves the determination of the energetic and work quality of the chaffing process. The study of the effects of stalk chaffing involves the determination of the effects of the chaffing process on the energetic and work quality of the maize stalk.

HOW TO COLLECT AND EVALUATE RESEARCH
DATA BY MEANS OF A
COMPUTER

The collection and evaluation of research data by means of a computer is a critical step in the research process. It involves the selection of the best practices for the collection and evaluation of the data, which are then used to conduct the experiment. This paper discusses the best practices for the collection and evaluation of research data by means of a computer, including the selection of the best practices, the preparation of the data, and the maintenance of the data.

ENERGETIC AND WORK QUALITY INVESTIGATION OF MAIZE STALK CHAFFING WITH ALONG-STALK DIGESTING

P. SZENDRŐ - L. BENSE - T. KISS
University of Agricultural Sciences, Gödöllő

In the Hungarian climate the silage maize plays an outstanding role as mass fodder. The harvest of the silage maize is a technically well elaborated task and the same time the loss consequent upon fermentation, storage and feeding partly can be still due to the imperfectness of the chaffing.

Among most known digesting and compactibility improvement methods are the crushing simultaneously with the chaffing or immediately following that. The technical solutions use crushing cage, roller pairs type corn crackers. They significantly reduce the mass rate of the self-propelled chaffers. The energy need increase has several reasons.

The most important are as follows:

- When installing a crusher cage the chaffing drum overtakes the role of a hammer mill which operates in very low efficiency level, due to its structural realisation.
- The corn cracker roller pair uses the principle of roller mill, but all the material flow goes through it (not only the grains) so that the energy consumption is extreme compared to the expected aim.
- Any type of crushing device built after the drum is an obstacle to the material flow which makes necessary to use a high energy demanding chaff reaccelerating unit.

Because of the disadvantages obvious to the operating people, many farmer ignore the crushing units. As for the manufacturer, they sell those units as orderable options although they manufacture them pushed by the competitors.

In the followings those investigations to develop equipments which can be built in self-propelled chaffers and apply to crushing treatment of green fodder's before chaffing are reported.

ANALYSING CLEANING PARAMETERS OF MILKING DEVICES

(Quality factors affecting milk production and milking with different type milking devices an OTKA - Hungarian Basic Research Fund - project)

Dr. L. TÓTH - Dr. A. TÚZ
University of Agricultural Sciences, Gödöllő
Dr. J. BAK
Hungarian Institute of Agricultural Engineering, Gödöllő

When considering the quality of milking and the produced milk, technical parameters of milking devices are classified in two groups:

- a) Parameters affecting milking efficiency and the health of the cow herds.
- b) Parameters determining milk quality

The clean-ability of the pipelines is of fundamental importance. The well cleaned machine will neither contaminate the milk nor infect the cow udder.

The efficiency of pipeline cleaning is significantly improved by introducing air in the ducts and such way the cleaning time and the amount of cleaning liquid are reduced. If the intake air is mixed in the cleaning liquid there will be a higher velocity, intensively eddying flow in the tubes implying highly effective cleaning onto the tube walls.

The size increase of short and long milk ducts and collectors stabilises the milking vacuum. From the point of view of cleaning

the controlled air intake is more advantageous. By the control, optimal conditions are reached even in quite varying circumstances, as for the cleaning liquid velocity and turbulence.

In the case of larger milking devices (with longer and greater diameter pipelines) the combined injector cleaning is proposed.

In this method one can adjust the following parameters as desired:

- volume of liquid
- chemical concentration
- cleaning duration

There is no doubt, that the technique exposes environmental benefits through the adjust-ability of these factors, also. (The waste amount and its storage cost and the environmental load is reduced, etc.)

TEST RESULTS OF THE PRODUCTION OF THE EXPANDED MIXED FODDER

I. CSIZMADIA
Fodder Industry Ltd, Bábolna
Prof. Dr. J. CSERMELY D.Sc. - Dr. Z. BELLUS -
Dr. M. HERDOVICS - Gy. KOMKA
Hungarian Institute of Agricultural Engineering, Gödöllő

At the fodder mixing plant No.1. of the Bábolna Fodder Industry Ltd a KAHL OE 30.2 type expander with a capacity of 24t/h has been running since March, 1995. By running this expander the HTST (High Temperature Short Time) technology is the very first one in use in Hungary. In the technology line the expander unit is between the mixer and the press equipment.

The investor has been initiated wide range of examinations in terms of utilization of the expanded mixed fodder. In the scope of the examinations the Hungarian Institute of Agricultural Engineering was entrusted to test the influencing technological factors of the physical-mechanical features of the pellet made by this process.

WEAK-POINTS OF MACHINE CONSTRUCTIONS AND A POSSIBLE METHOD FOR RECOGNISING THEM

P. VERMES - J. NAGY
University of Agricultural Sciences, Gödöllő
College of Agricultural Engineering, Mezőtúr

In an earlier paper of us [1] a short survey was given on the process of failure analysis and its applicable methods. The weak-point terminology was discussed and the serviceability analysis steps in the weak-point recognition was only touched. In the present article discusses some aspects of the construction, the weak-point recognition and the maintenance and the computer assistance possibilities for weak-point recognition.

HOW TO COLLECT AND EVALUATE MEASURED DATA BY MATHEMATICA?

L. OROVA Dr.
University of Agricultural Sciences, Gödöllő

The fact that a human being does not like to make routine tasks led to the quick development of computer science. The collection, registration and evaluation of large number of measured data are the day-to-day work of engineers, agronomists, biologists, etc. Their work cannot dispense with the computers.

Although most of the programs are able to do statistics to some extent it may be interesting how to process data with a software of symbolic mathematical operations, with *Mathematica*. The article presents some examples for normal distribution, interpolation, regression, and analysis of fitting.

TEST RESULTS OF 150-200 KW POWER OUTPUT HEAVY UNIVERSAL TRACTORS

Dr. M. SZENTE

Hungarian Institute of Agricultural Engineering, Gödöllő

Dr. I.J. JÓRI

Technical University, Budapest

For the Hungarian agricultural production the modernisation of the tillage aim high performance power machine stock has a great importance. That should not mean only the replacement of the existing power machine fleet with new machines but technical development, too. The aim of the production efficiency and economy imply new and greater requirements to the power machines of the basic tillage, as well. Taking those requirements also into consideration one has to establish new system of higher requisites such as proper performance, economy, low specific consumption, environment friendly engine, powershift transmission gear the attachability of the existing implements of RÁBA 250 tractors, favourable energetic operation, electrohydraulic control of lifting equipment.

TWO-DIMENSIONAL FINITE ELEMENT ANALYSIS OF SOIL CUTTING BY MEDIUM SUBSOILER

ABDUL MOUNEM MOUAZEN - Dr. M. NEMÉNYI

Pannon Agricultural University, Mosonmagyaróvár

Two-dimensional finite element model was developed by which the work done by medium subsoiler was simulated. Loosening of sandy soil was investigated not only by the shank and chisel of the subsoiler separately, but also with both together. The soil was considered as nonlinear elastic-perfectly plastic material. By the constructed model, the loosening of layered agricultural soils can be assessed (e. g. loosening of a hard pan that generally results from repeatedly applying of mouldboard plow or disc harrow at same cultivating depth).

EXAMINATION OF WORK ORGANISATION QUESTIONS OF THE SHEEP HUSBANDRY

L. LENGYEL - I. TÓTH

University of Agricultural Sciences, Gödöllő

College of Agricultural Engineering, Mezőtúr

In the last years the high rate decreasing in the stock has stopped and a moderate expansion is forecasted. The reasons are the improving market position of the meat and milk products and so the possibilities getting more income.

The debates about the utilisation directions can be considered as finished - due to the results of the scientific research. The overwhelming part of the professionals agree on the economical reasonableness of the specialisation. The market need promotes the meat, milk and the double utilisation directions. In the double utilisation both meat and milk can be the first utilisation aim.

The chosen technology and its frame, the **rational operation organisation** is an outstandingly important factor for the successful realisation of the utilisation direction.

The organisation of the work - according to the general (and accepted) terminology - is such an aimful, planned and continuous control activity which supports the efficient utilisation of the available sources and production factors (assets, workforce, biology resources) for the given tasks. The forming of the organisation is influenced by technology features, division of labour, the type of working phases and operations, the largeness of the branch, and so on.

The examination of the applied technology and the work organisation can produce much information to judge the efficiency and earning capacity of the production.

SIMULATION POSSIBILITIES OF CLIMATE CONDITIONS IN GREENHOUSES

M. SZABÓ - Dr. I. BARÓTFI

University of Agricultural Sciences, Gödöllő

The tested model describes the processes taking place in greenhouses most completely. This model is suitable for the simulation of climate conditions of mulch and greenhouses with different structure and type (mulch, row cover, plastic tunnel, simple and double covered greenhouses, glasshouse) with different type of covering materials (glass and plastic film). The processes can be defined in the course of simulation at any time, at any time interval, at any climate conditions, and at any geographical place.

There are a lot of elements and details elaborated -not yet too exactly- in relation to vital processes by plants, to thermal and light conditions, to the connection between outside environment, radiation, and the greenhouse. For example, it can be a problem to use the correct value for giving the average temperature and the amplitude for temperature outside (initial values). This model is destined to estimate the daily development of climate elements at any time in a year, at any day as exactly as possible.

It can be determined by our and others' research in this field, that the condition of covering material is not negligible in the radiation and light conditions in greenhouses. This factor is left out of consideration by the known models. That is why the models have to be formed more correct in the determination of the connection between the covering material conditions (ageing and condensation) and the inside climate ones. Now the researches and experiments are directed to find out the adaptation of the worked out programs, and they show in the direction of the exact revelation of connection between the light- and radiation transmissivity and condition of covering materials.

MEASURING ODOUR EMISSION OF POULTRY HOUSES, THE EXPERIENCES OF THE MEASUREMENTS

A. BÉRES - Dr. A. MITYÓK

University of Agricultural Sciences, Gödöllő

College of Agricultural Engineering, Mezőtúr

The professionals began to deal with the environment pollution odour effect of the animal husbandry at the beginning of the 1960 years. In the animal houses and barns as well as in the animal farms the increase of the animal stock caused an increase in the liquid and litter manure quantity and the amount of smelly materials, too. Almost everybody has his/her own experience with smell emission of the large scale plants. The inhabitants of the nearby villages know especially well the features of the animal farms located too close to the habited areas without considering the typical wind direction and the features of the ground.

ANALYSIS OF GRINDING'S BASIC ENERGETIC RELATIONSHIP (OTKA T 016124)

Dr. I. BÖLÖNI

Hungarian Institute of Agricultural Engineering, Gödöllő

- 1) The specific superficial grinding energy consumption e_s (kWh/cm²) is a positive linear function of the specific grinding energy requirement e_g (kWh/t), if the specific surface increase of grit Δ_{ag} (cm²/g) remains constant.
- 2) The specific grinding energy demand e_g (kWh/t) is also a positive linear function of the specific surface area increase Δ_{ag} (cm²/g), if the specific superficial grinding energy consumption e_s (kWh/cm²) equals constant. The larger the specific surface area increase Δ_{ag} (cm²/g) (i.e. the grit fineness) is, the bigger specific grinding energy requirement e_g (kWh/t) amounts and reversely.
- 3) The specific superficial grinding energy consumption e_s (kWh/cm²) is a first grade hyperbolic function of the specific surface area increase Δ_{ag} (cm²/g), when the specific grinding energy demand e_g (kWh/t) is kept constant.
- 4) Its inverse function $e_s(e_g)$: specific grinding energy requirement (kWh/t) – specific grinding energy consumption (kWh/cm²) also makes a first grade hyperbolic function, if e_g (kWh/t) = constant.
- 5) From the two specific energy demands e_s (kWh/cm²) the specific superficial energy consumption seems to be an independent variable, – as a physical property of the ground material (in case of us, feed grain). If e_s value is low (i.e. the material is easily to be broken), – the grind will be fine, if e_g (kWh/t) = constant. Oppositely, when e_s (kWh/cm²) is high, coarse grit should be expected.

AMMONIA EMISSIONS FROM COMPOSTING ANIMAL WASTES IN WINDROWS

K. CSEHI - J. BECK - T. JUNGBLUTH

University of Hohenheim,

Institute of Agricultural Engineering

It can be concluded that the absorption principle NH₃ measurement is suitable method to determine the NH₃ emission directly. The measuring technique developed for clamp composting should be however with high emission (low C/N ratio) material composting. As the different compost making processes and the different material properties significantly influence the behaviour of the process, it is necessary to carry out of the above mentioned experiment. In the course of windrow composting the homogenisation and the complete hygienisation is ensured by the proper rotation rhythm. However, the continuous temperature control is essential. The quality of the samples examined so far meet the prescription of the „Bundesgütegemeinschaft Kompost“ conditions for commercial introduction. The fresh compost produced in the experiments is applicable to use for soil improvement and as fertiliser and the matured compost as black mould.

COMPUTER IMAGE PROCESSING POSSIBILITIES IN THE EVALUATION OF TILLAGE AND FERTILISER SPREADER MACHINES

Dr. GY. DEMES - S. SALAMON

Hungarian Institute of Agricultural Engineering, Gödöllő

Dr. JÓRI J. ISTVÁN

Technical University, Budapest

The computer image processing was accomplished based on the Machine II real time video digitiser card of FAST Electronic

GmbH (Germany, München). The card was installed in an IBM 386 DX personal computer and the general purpose image processing software DigiCell 4.0 version of ASK Ltd. (Hungary, Budapest) as well as a commercial JVC-GA/Ax55 VHS/C video camcorder with a CCD camera were also used. This minimal apparatus makes possible the evaluation of the video records in computer. The modular DigiCell program package run under Windows 3.1 (or higher) and uses pull-down and icon menus. The application is flexible enough and is applicable to measure the image characteristics and parameters of the single video pictures.

EXPERIMENTS CARRIED OUT WITH ACTIVE CUTTING ELEMENT TILLAGE TOOL

Dr. L. FENYVESI

Hungarian Institute of Agricultural Engineering, Gödöllő

T. MEZEI

University of Agricultural Sciences, Gödöllő

Based on the previous research and development results the aim was to make such a tool, where the motion of the cutting plate of the traditional plough serves the favourable energy saving affect. Such way the breast does not move, so that no resistance increase should be considered. The vibration system is formed by springs giving motion in parallel and perpendicular directions to the plough edge. The system contains no external driving, so that the excitation depends mostly on the spring parameters (selfexcitation system).

RELATIONSHIP BETWEEN SCREEN SURFACE GEOMETRY OF HAMMER MILLS AND ENERGETIC PARAMETERS

M. DOUBA - Dr. L. FOGARASI - Prof. Dr. P. SEMBERY

University of Agricultural Sciences, Gödöllő

Changing the peripheral speed of the hammers, the mass performance of the hammer mill has a maximum value between 65 and 70 m/s. The energy consumption of the mill shows an optimum at around that velocity values. Of course, the fineness of the product will grow with the increasing of the speed. The relationships show that the 'expanded plate' screen is equivalent with screen $\phi 5$ mm in fineness production. (The specific surface area is calculated from the particle size distribution data, so $dA/dt = m\Delta a_f$) It is very clear from the diagram that the 'edges' of the screen holes play an important role in the comminution and the energetic properties of the 'expanded plate' and drilled screens are better. Moreover the active surface area of the screen 5 d2 is bigger than the conventional screen $\phi 5$ or 5 d1!

The constant lines as energy levels prove the same and it has to be remarked that the operation ranges do not cover each other at all.

EVALUATING THE TECHNICAL PRODUCTION CAPACITY OF AGRICULTURE

Dr. J. HAJDÚ - Dr. Z. PESZEKI - Dr. I. TAKÁCS

Hungarian Institute of Agricultural Engineering, Gödöllő

In the course of the transformation of the agriculture great changes has come about the state of machine stock, ownership structure, machine usage practice and the operations, as well. The aim of the research to resurvey the changes of machine stock and production capacity and to examine the relations of production tasks and the machine capacities.

In the elaboration of the topic the present potential of the machines and implements have been examined and compared to the ten years ago stock and capacity figures. The nominal capacity of the complete stock is corrected by factors characterising the wearing out and technical state of machines, and so determining the real capacities in general and for each groups.

The investigations accomplished, and the evaluations produced the result, that the machine stock decreased by more than 6 % in the examination period resulting also a fall in the machine capacity. Even a greater capacity fall presented itself due to the machine ageing and wearing out. Whilst ten years ago the machines were able to produce 76 % of their nominal capacity, the relevant figure is only 60 % now. The average operation time of the implements was reduced from 940 to 670 working hours.

EXPERIENCES OF THE CONSERVATION CORN PRODUCTION AT 1995.

Dr. S. SOÓS - Dr. I. SÖRÖS
Hungarian Institute of Agricultural Engineering, Gödöllő

In the past years some experiments have been carried out to establish the technological and technical bases of the Conservation Corn Production. In connection with this the existing technical solutions, machine modifications and developments were sought and the lacking machines were bought.

The technical aggregate was mainly established on our own resources adapted to the already existing home machine aggregates. On this basis, production technology experiments were carried out to judge the home applicability of corn production technologies.

The United States is considered as the base of the adaptation experiments, where four different corn production technologies are in usage, such as mulch, band, ridge and direct planting. Till the beginning of 1995 the nonploughing technology was used, like cheesel plow, subsoil loosener and heavy disk. Those experiments applied seeding in mulch and band planting technologies. The examinations are included in the previous years reports of us.

The other two nonploughing corn production technologies which has not been examined in detail so far are the direct planting and the ridge ones. The investigations started in this year (1995).

The aim of this was to modify the Planter of type KÜHNE-CASE-IH-Cyclo-800 to applicable to use for direct planting and ridge planting. Using such type of set-up production technology experiments was accomplished in direct planting and in starting the technology preparation for ridge cultivation with building up ridges. So that our this year investigations focused on the direct planting technology.

Another goal of the 1995 year investigations was to carry out further technology experiments with the nonploughing corn production technologies in order to practical set-up and yield registration. The Tillage equipments had been: CONSER TILL-4,2 cheesel plow and KÜHNE-CASE-IH-10-770 heavy disks in 1995 for the nonploughing corn production technology experiments.

ELEKTROSTATIC SPRAYING RESEARCH AT APPLE PLANTATIONS

I. KALMÁR - E. PETRÓ
University of Agricultural Sciences, Gödöllő
College of Agricultural Engineering, Mezőtúr

Nowadays, the uses of chemical saving, environment friendly and plant protecting methods are spreading wide in the intensive

fruit-gardens. In Hungary, we have tested the application of the MARTIGNANI kwh electrostatic drop-filling spray machine at some apple-plantations.

In summary, we found the above-mentioned machine applicable in traditional fruit-gardens. Beside the optimum research conditions, the according to figure savings and advantages mentioned by the manufacturer can be probably reached, but there are needs for further testing.

TECHNOLOGICAL DEVELOPMENT FOR IMPROVING THE QUALITY OF FLUE-CURED TOBACCO

Dr. B. KERÉKES
University of Agricultural Sciences, Gödöllő
College of Agricultural Engineering, Nyíregyháza

Our institution has been working on the examination of the basic characteristics of flue-cured tobacco for five years. The main elements of this research work are the following: measurement of thermal features, the monitoring of colour-changes and the examination of some of the physical parameters. At present we only measure the levels of the most important chemical components (carbohydrate, total nitrogen, reducing sugar, nicotine).

The measurement of some of the chemical components has shown that there is a close relationship between the quality categories and the chemical characteristics of flue-cured tobacco. The amount of reducing sugar and total nitrogen varies considerably, depending on the curing schedule. The nicotine content does not change significantly. This means, that we are not able to influence the nicotine content by using this curing technology. Another result is clear, that the quality alters at different ripening levels.

In Hungary it is very important to improve the quality of flue-cured tobacco. The author hopes that the new (advanced) applied curing schedule can contribute to this.

SOME EXPERIENCE WITH MEASURING THE SMELL EMISSION OF PIG HOUSES

Dr. A. MITYÓK - A. BÉRES
University of Agricultural Sciences, Gödöllő
College of Agricultural Engineering, Mezőtúr

As it is well known the animal husbandry houses indicates their presence by odour. As the animal husbandry is unavoidable due to their role in the food production, the people accept the activity; in the most family houses of the villages and towns people keep some kind of animal. The properly kept few pigs and few tens of poultries can be well tolerated and is an everydayness phenomenon. The greatest repulsion to the animal keeping is generated by the smelly odour independently on that the objector person grows animal or not. The problem arises when the large scale farm model is used in small animal houses, because the necessary conditions of the transferred technology do not exist. The lacking conditions may be the lack of the manure deposition technicalness, of the afforestation made according to the human and animal hygiene aspects which defends against noise and smell and of the protective distance meeting the home regulations. The animal husbandry plants pollutes the environment in several ways and among the others by their odour from the smelly materials produced in operation.

In our department the odour effects of the animals of poultry and pig houses are also examined.

The research aim is to search relationships between the different animal husbandry technologies, keeping methods, the number of animals and the resulted odour for obtaining solution to reduce the odour emission.

ENERGETIC AND WORK QUALITY INVESTIGATION OF MAIZE STALK CHAFFING WITH ALONG-STALK DIGESTING

P. SZENDRŐ - L. BENSE - T. KISS
University of Agricultural Sciences, Gödöllő

In the Hungarian climate the silage maize plays an outstanding role as mass fodder. The harvest of the silage maize is a technically well elaborated task and the same time the loss consequent upon fermentation, storage and feeding partly can be still due to the imperfectness of the chaffing.

Among most known digesting and compactibility improvement methods are the crushing simultaneously with the chaffing or immediately following that. The technical solutions use crushing cage, roller pairs type corn crackers. They significantly reduce the mass rate of the self-propelled chaffers. The energy need increase has several reasons.

The most important are as follows:

- When installing a crusher cage the chaffing drum overtakes the role of a hammer mill which operates in very low efficiency level, due to its structural realisation.
- The corn cracker roller pair uses the principle of roller mill, but all the material flow goes through it (not only the grains) so that the energy consumption is extreme compared to the expected aim.
- Any type of crushing device built after the drum is an obstacle to the material flow which makes necessary to use a high energy demanding chaff reaccelerating unit.

Because of the disadvantages obvious to the operating people, many farmer ignore the crushing units. As for the manufacturer, they sell those units as orderable options although they manufacture them pushed by the competitors.

In the followings those investigations to develop equipments which can be built in self-propelled chaffers and apply to crushing treatment of green fodder's before chaffing are reported.

Energetic investigation of the precrusher device

Our experimental device, called press unit is a pair of roller like a corn cracker. The circumferential speed of its can be adjusted by hydrostatic driving. The constant pressing force and the stuck-free flow is ensured by roller suspension controlled by hydraulic working cylinders. The experimental press unit is built in a Jaguar 685 SL type self-propelled chaffing machine modified to a stable measuring stand. The press unit is mounted between the feeding apparatus and the chaffing drum. The machine was fed with maize stalk batches. The arrangement of the chaffing unit completed by the press is shown in fig. 1. The experimental set-up is shown in fig. 2.

The pressure of the working cylinders can be adjusted between 0 and 180 bar which corresponds a compacting force of value 0 to 45 kN. Considering, however, that the compacting force of the factory made feeding device applying spring grasp implies 4 to 9 kN compaction force depending of the oscillation of the material flow and that can not be eliminated, instead of the unsettled total compaction force the working cylinder pressure resulting the increment is included in the diagram. The moment undertaken by the press unit was measured on the output shaft of the drive gear by means of gauges. The power data of prepressing is exposed in the column diagrams of the fig. 3, 4, 5 and 6. (Each piece of data is a mean value to three measurements).

From data analysis one can see that any increase in the press force and flow rate all results in significant raise of the crushing and transport energy need. The question is if this investment is returned in the chaff quality and the elimination of postaccelerating unit, or not.

The fact that the press unit comes before the chaffing drum implies additional advantage, i.e. it can reduce the cutting energy, because the blades will not deform and compact the material before the cutting. On the other hand the crushed material will be more difficult to support and may result in chaff quality decrease.

Quality parameters of precrushed chaff bulk

Silage corn chaff length distribution as approximated through six parameters

For saving space, only two bulks the most different from the point of view of mechanical pre-processing are considered and the approximation of their empirical distribution functions (SZENDRŐ, 1995) are shown here. Those are one without crushing and the other compacted by 35 kN crushing force (fig. 7, 8).

The physical meaning of parameters:

- M1 - expected value of chaff length
 - S1 - distribution of the expected value of the chaff length
 - M2 - maximum chaff length
 - P - the single cut (normal distribution) part
 - Q - shatter (even distribution) part
 - R - oversized (parabolic distribution) part
- $P + Q + R = 1$

Rheology investigations

The rheological parameters (relaxation time, retardation time, etc.) are the most practicable to compare the crushing state of chaff bulks. The typical processing method of the corn chaff is making compacted silage for lactic acid fermentation. The compaction can be modelled as uniaxial compression. A simple and reliable method was elaborated for the creep test of chaff bulks (fig. 9).

To eliminate the subjective error of the person who loads the bin of the sample bulk and to neutralise the different settlement of the different density bulks the identical volume mass was ensured by the application of a 2.6 kPa preload. The main load magnitude (12.6 kPa) was selected according to the dynamic effect arising at the load application instance and to ratio of the sample column height to the greatest deformation. The deformation was measured by linear inductive displacement sensor with a 0.1 second period. The evaluation of the recorded creep curves was made by putting the curves on each other and comparing their characteristic points by means of simplified linear viscoelastic models and rheological parameters. Based on the creep curves one can make the parameter called creep decay time which is the time necessary to the deformations speed for decreasing to 1 mm/min (fig. 10).

While the demonstration of the creep curve are skipped the bulk elastic-after-effect versus the greatest deformation can be a further important piece of data for rheological qualification (fig. 11).

Both diagram shows that the mechanical treatment of the silage maize before chaffing has a favourable effect on mechanical properties of chaff bulk. Its elasticity is reduced and the compactibility improved. At the same time basically the other data of working quality are unchanged. Taking into account all these the idea of crushing before chaffing can be the source of considerable advantages, so that this equipment development, energetic and process quality research are to be continued.

References

- [1] SZENDRŐ, P.: Chaffing of green fodder. Akadémiai Kiadó, Budapest, 1995. p. 157
- [2] SZENDRŐ, P. - PETRÓCZKI, K. - NAGY, J. - BENSE, L.: The interrelationship between the size range and the rheological properties of alfalfa chop. Hungarian Agricultural Engineering, Gödöllő, N°2., 1989. pp. 14-17

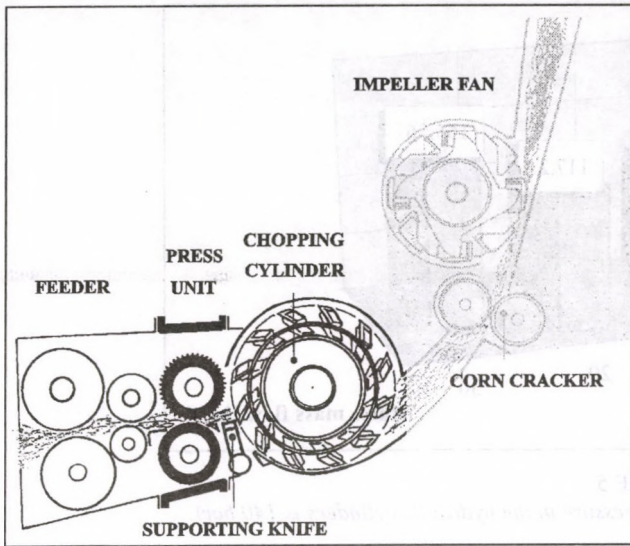

FIGURE 1

Disposition scheme of the chaffing machine completed by a press unit (the thick lines indicate the fitted device, while the grey tone picture part is taken out from operation)

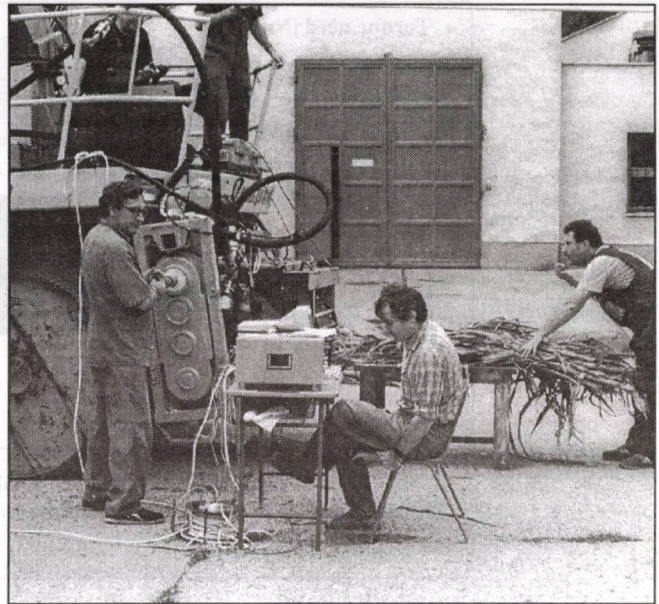

FIGURE 2

Energetic investigation of the press unit

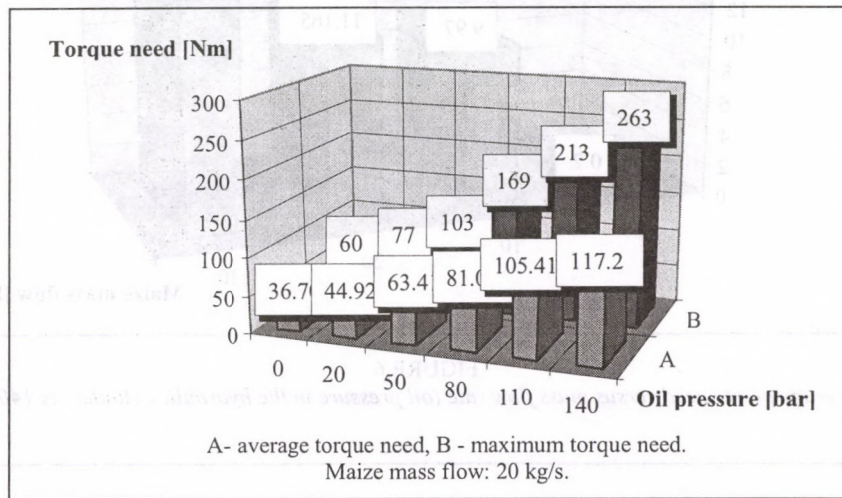

FIGURE 3

The torque need of press unit

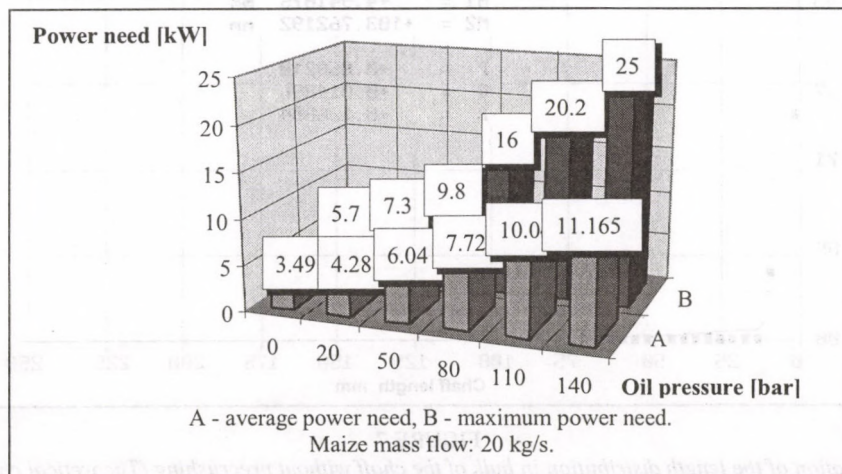

FIGURE 4

The power need of press unit

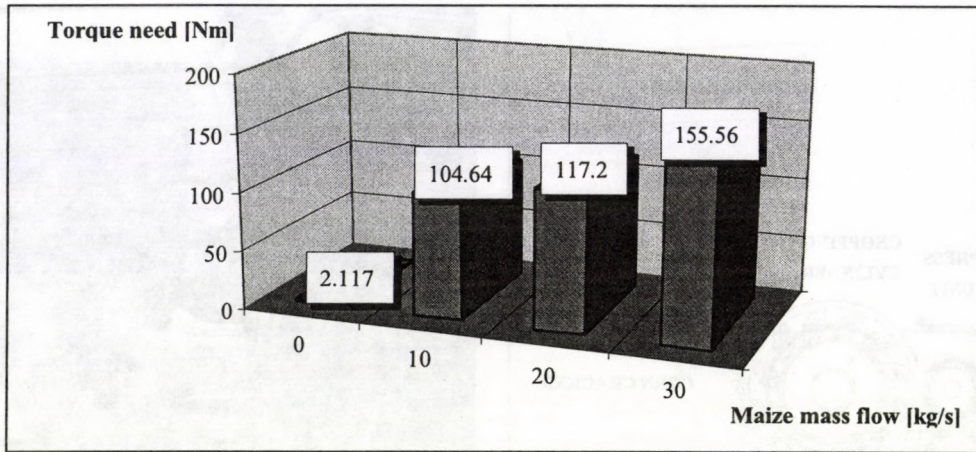

FIGURE 5

The average torque need versus mass flow (oil pressure in the hydraulic cylinders is 140 bar)

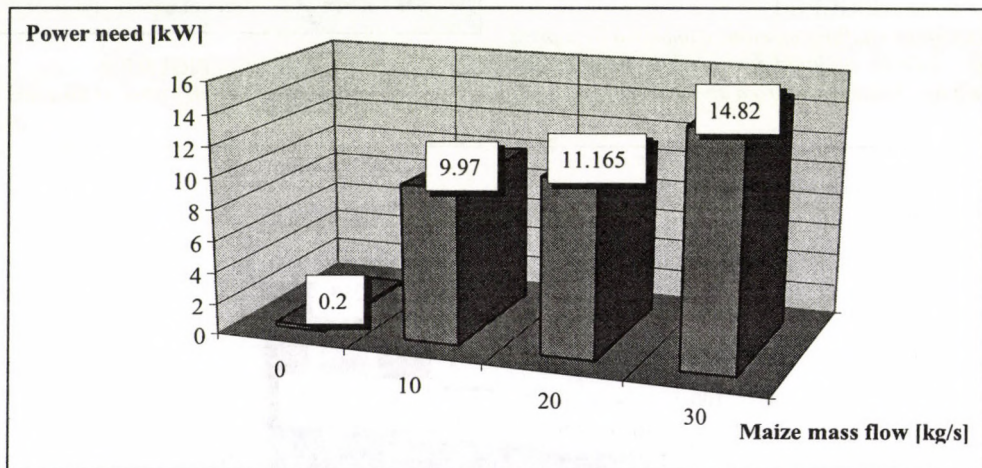

FIGURE 6

The average power need versus mass flow rate (oil pressure in the hydraulic cylinders is 140 bar)

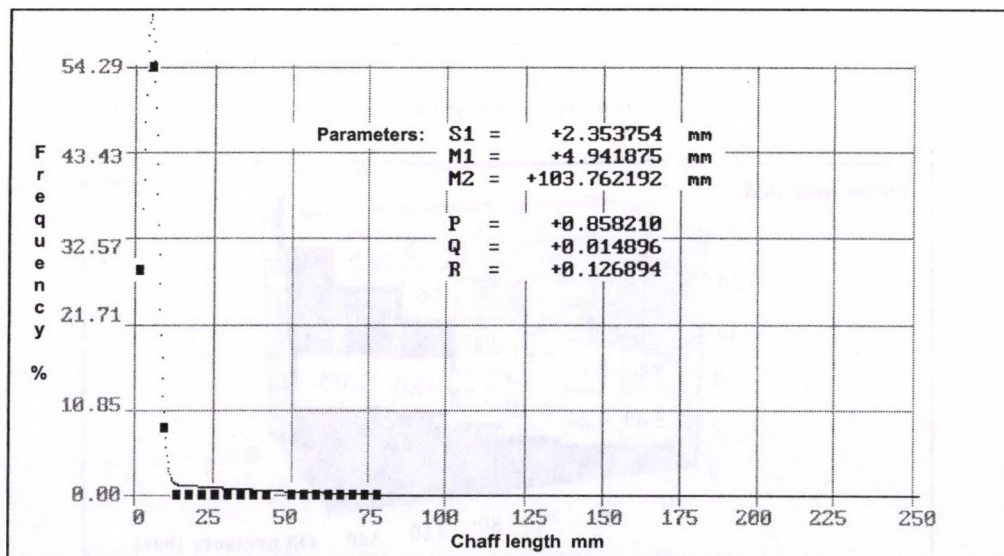

FIGURE 7

Six parameter approximation of the length distribution in bulk of the chaff without precrushing (Theoretical chaff length is 6 mm. The expected value of the complex distribution is 8.22 mm, its variation is 11.2 mm. The oil pressure is 0 bar in the precompacting device. Machine type is Claas Jaguar 685 SL, $Q = 20$ kg/s.)

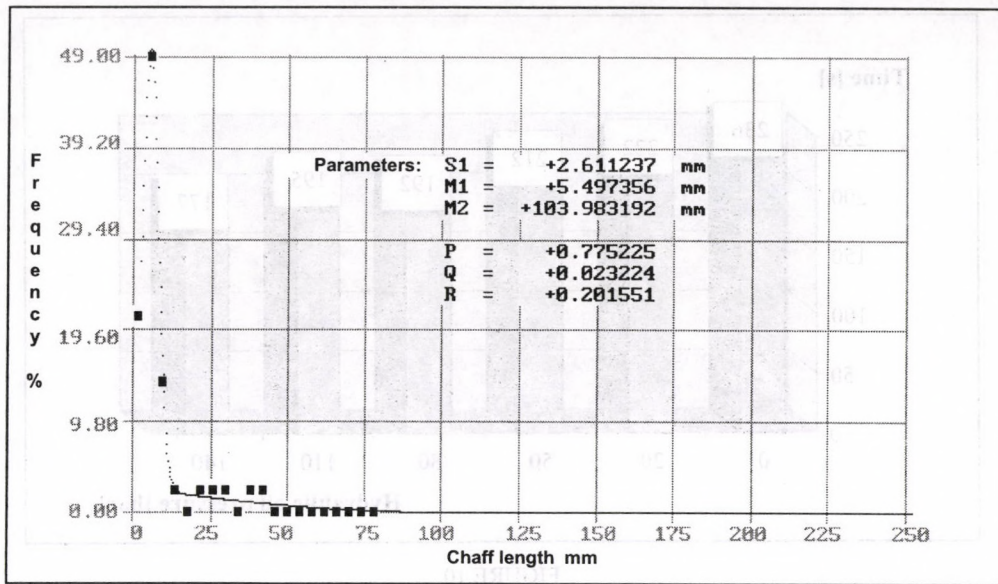

FIGURE 8

Length distribution in bulk of the chaff after 35 kN load precrushing (Theoretical chaff length is 6 mm. The expected value of the complex distribution is 10.4 mm, its variation is 13.18 mm. The oil pressure is 140 bar in the precompacting device. Machine type is Claas Jaguar 685 SL, $Q = 20$ kg/s.)

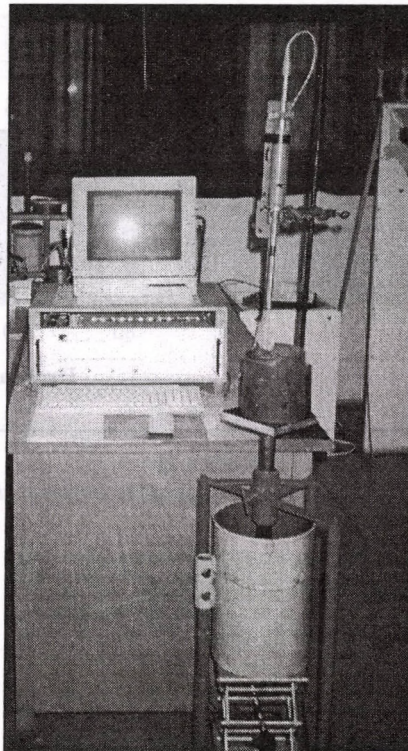

FIGURE 9

Experimental set-up for creep measurement

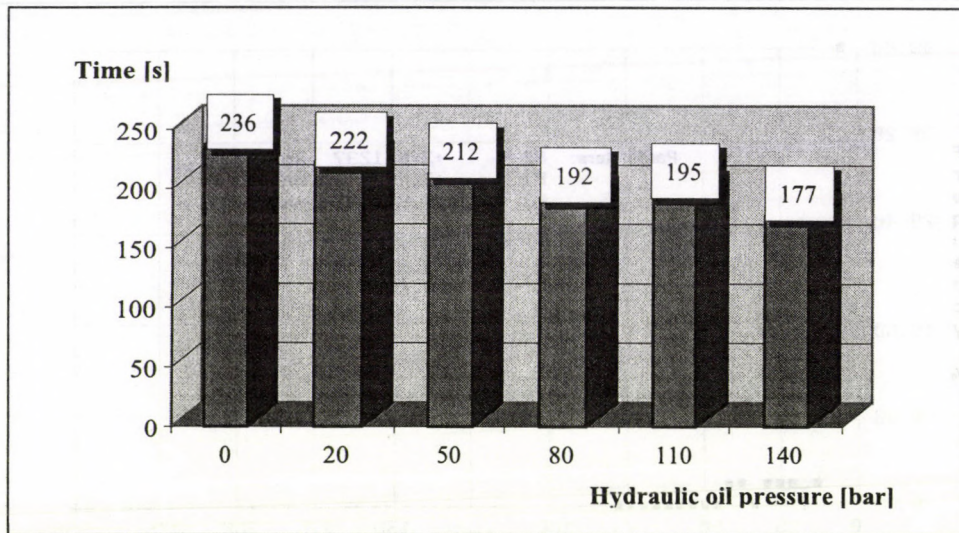

FIGURE 10
Creep decay time (to when the deformation velocity decreased to 1 mm/min)

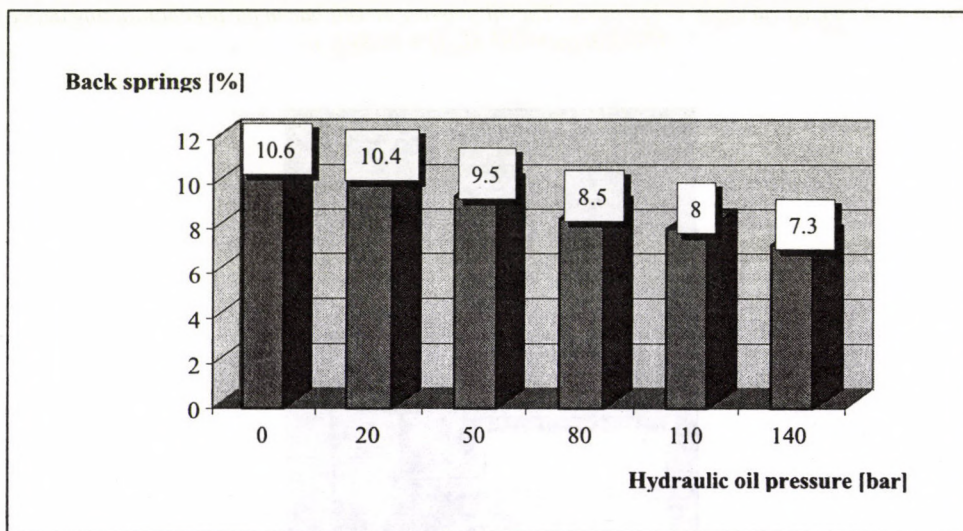

FIGURE 11
Elastic-after-effect as the percentage of the maximum deformation

ANALYSING CLEANING PARAMETERS OF MILKING DEVICES

(Quality factors affecting milk production and milking with different type milking devices an OTKA - Hungarian Basic Research Fund - project)

Dr. L. TÓTH - Dr. A. TÚZ

University of Agricultural Sciences, Gödöllő

Dr. J. BAK

Hungarian Institute of Agricultural Engineering, Gödöllő

Abstract

While conducting research in laboratory, the advantageous flow parameters of milking apparatuses have been revealed. Udder model was applied to the determination of near-optimum parameters of milking devices. Another model supplied the practical liquid flow parameters of washing. Proposals has been compiled for optimum parameters of milking devices and for the solution of air-added cleaning method, which improves the cleaning efficiency.

The aim of research

The investigation goals have not changed since the time of application:

Scientific, experimental measurements assisted analysis of the basic parameters which determines the quality of milking and milk production significantly.

Experimental set-up

The equipment shown in the sketch of figure functionally corresponds a complete milking device (fig. 1).

To record the flow picture and to determine flow velocity videorecorder was employed. The videorecord was then evaluated on single pictures, one by one, getting the changes of flow.

The initial value of 1/1 water and air volume was varied. The highest air/water ratio was 175. The video „frames” supplied the displacement value in 0.04 second considering the measurement section. That corresponded 12.5 m/s flow velocity (the length of measurement section was 500 mm).

The results were processed and included in diagrams. Before making the final conclusions, the measurements were carried out in static state, as well. Such way the aspiring velocity of smaller and larger bubbles at different vacuum levels. They were necessary for evaluate the changes of vertical flow picture.

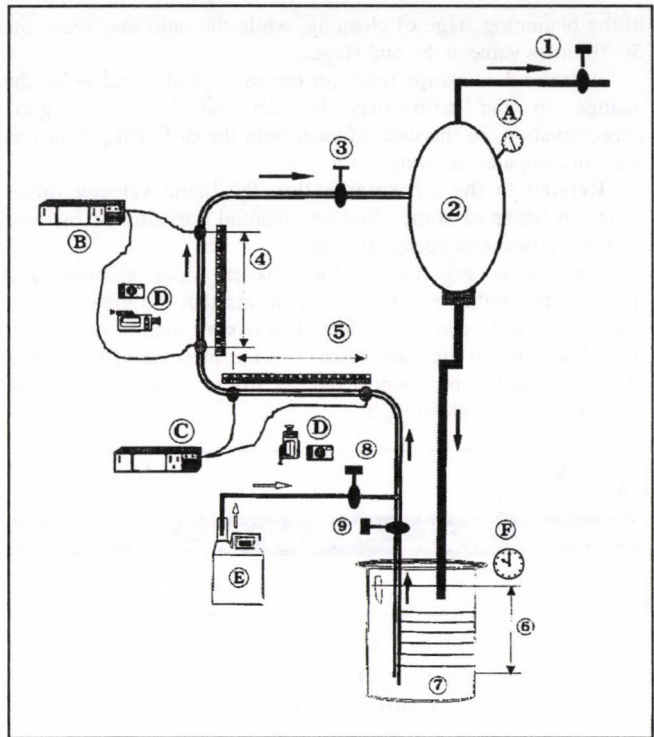

FIGURE 1

Draft of measurement

1- vacuum pipeline; 2- milk separator; 3- milk pipe; 4 and 5- measurement sections in the milk pipeline; 6- level gauge for measuring liquid; 7- measuring liquid tank; 8- air inlet controller; 9- liquid inlet controller; A- vacuum meter; B- vacuum recorder; C- vacuum recorder; D- flow picture recording (video recorder, camera); E- air volume meter; F- clock

The results of the investigations

Effect of filling ratio

The run of air to water ratio was determined as a function of water inlet orifice in seven grades. The number variations of air filling in was extended (by air holes) to form 4 additional groups.

When the air filling is made unlimited the ratio can have even 200-300 times value. In milking devices 2-10 times values occurs

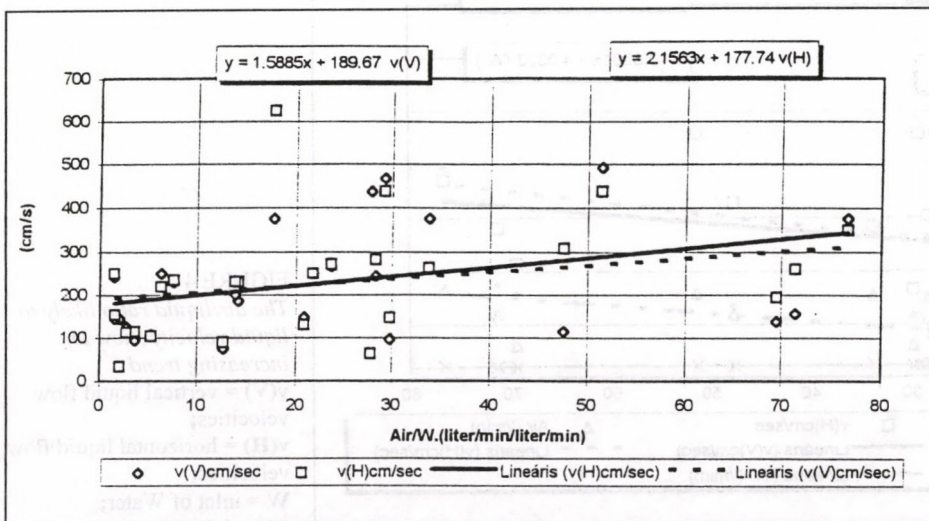

FIGURE 2

The vertical and horizontal liquid flow velocities, the change of variation of air/water in time $v(V)$ = vertical liquid flow velocities; $v(H)$ = horizontal liquid flow velocities;

at the beginning stage of cleaning, while the ratio may reach the 50-70 times value at the end stage.

As the relationships read, on the case of identical holes the change in the ratio may be determined with a good approximation. In the case of each hole the different parameters were investigated separately, too.

Related to the air/water ratios, the liquid velocity values show up linear or some close exponential variation of increase both in vertical and horizontal tubes.

Increase is experienced for smaller water volumes and decrease for higher water volumes means that the greater water volume has a decelerating effect. The overall picture shows that in the case of too high air/water ratio the increase of velocity is lower. The optimum value of ratio is around 5 to 15, when the flow velocity is high enough.

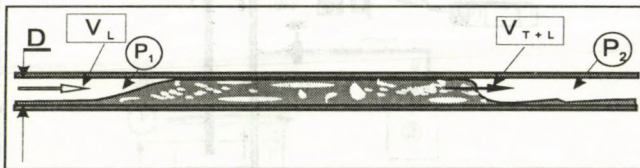

FIGURE 3

Flow picture in a horizontal tube as depicted as a result of measurement analysis

In the case of small water volume and low air/water ratios the flow has a waving characteristic, and long waves are formed, which make jams and deliquesce after long flow that is the waves are deliquescent. In the case of large amount of water and low air/water ratio, when the filling up of the two pipes is around 80 %, the liquid flow becomes irregular and short bubble giants and liquid jams follow each other. Then completely irregular eddying flow is formed in the vertical section. In general, the highest liquid flow velocity is reached when the tube filling up is high (higher than 50 % based on flow picture) and the value of air/water ratio is between 5 and 10.

The air/water (liquid) ratio

The greater amount of air – by causing lower specific volume – will get the air and water mixture to have higher instantaneous flow velocity at the same pressure. This was obeyed in every

experimental measurement, as one can see an exponential trend for larger air/water ratio.

If the ratio related to the tube diameter is not changed the tendency is opposite, being due to the fact that the liquid amount (filling up) is too small and air flow is above the liquid resulting only in waving. In the vertical tubes the air ascends (and the water falls back).

The formulations of velocities related to air/water ratio are given in Supplement 4.

When the filling up is raised the increasing tendency of liquid speed is still valid, but it becomes more unbalanced (it is rather decreasing for horizontal flow and increasing for vertical flow).

In the vertical tube there is an irregular eddying flow (which causes an intensive mechanical load on the tube wall). The waves in the horizontal tube and the wave formed whole cross-section liquid jams disappear. Instead, spraylike flow of smaller and larger liquid droplets of much higher velocity emerges.

The extent of eddying is so high in the vertical tubes, that it is difficult too recognise the flow pattern. Extremely high velocity values are found when the flow in the vertical section is formed of different size eddying bubbles rather than of the sequence of huge bubbles and liquid jams .

The variation of velocity is considered important because the flow speed will increase the extent of turbulence and the cleaning effect, too.

The air/water volumes ratio is so important for the water consumption, as the deposition of the cleaning material costs a lot, not mentioned that higher amount cleaning liquid needs more cleaning material if same concentration applies. Therefore, the analysis of the flow patterns and velocities helps to find the optimum ratio which can arrive at saving some energy and cost.

The vertical and horizontal sections

An intensive eddying is always experienced in the vertical and inclined tubes at higher air/water ratios. In the vertical tube sections the air always advances while the liquid whirls back turbulently.

In the case of horizontal flow and lower filling up the air always flow away above the liquid surface. Thus it is not possible to obtain an effective washing in the case of smaller filling up even there is a virtually intensive flow. One should make an effort to achieve a higher filling up. The drawback is that the cleaning material consumption will grow for longer pipelines in such cases.

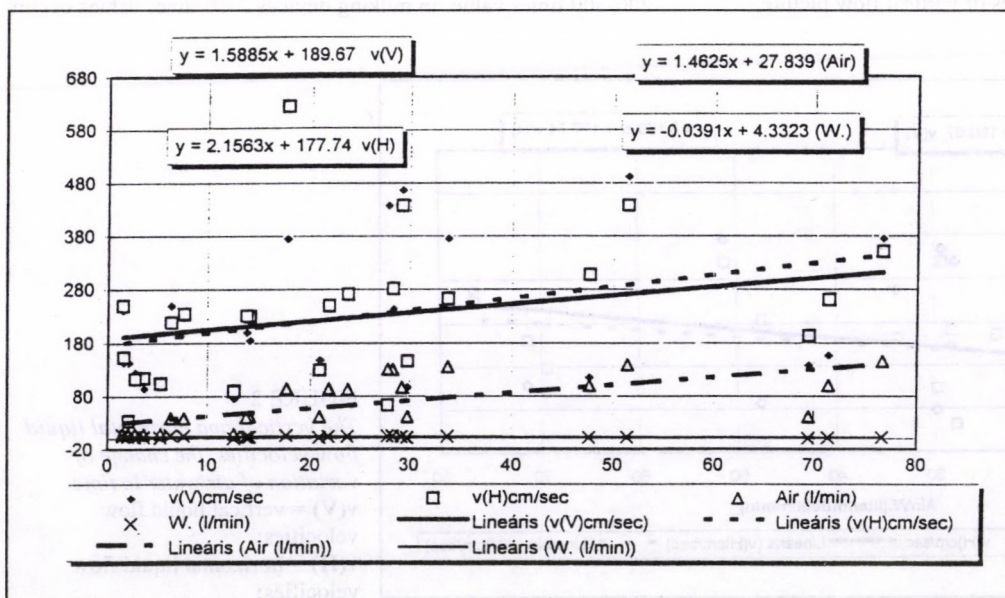

FIGURE 4
The air/liquid ratio likely to liquid velocity show an increasing trend
v(V) = vertical liquid flow velocities;
v(H) = horizontal liquid flow velocities;
W = inlet of Water;
Air = inlet of Air

It is more advantageous if the liquid and air leading-in is made periodically that is one should produce high filling up for a short period especially using little air intake for higher turbulence and flow velocity, followed by air introduction period.

Such way in the tube sections to be cleaned longer „liquid jams” are produced and followed by large air bubbles (when liquid introduction is discontinuous). The time distribution of liquid introduction (frequency) should be determined depending on the tube length and tube diameter. The factors belonging to the periods can be calculated only with poor approximation, so that the normatives should be produced by experiments, then making some in situ corrections after installation.

The combined injector washing is proposed, which proved itself the most effective in the investigations. In this procedure the milk separator pump feeds the cleaner liquid of 40-50 kPa pressure in the washing pipeline.

The milking duct is mounted on the other side of milking device, in which the flow is possible controlled by an injector. So that predetermined liquid jams and air bubbles follow each other and the flow is driven by 50 kPa vacuum, too. But the flow is generated an approximate 100 kPa pressure difference. Its advantages:

- high flow velocity and turbulence (due to the greatest pressure difference)
- controllable flow in the milk duct
- the pulsating washing liquid flows through the total cross section of the milking device

Summary of results

When considering the quality of milking and the produced milk, technical parameters of milking devices are classified in two groups:

- Parameters affecting milking efficiency and the health of the cow herds.
- Parameters determining milk quality

The clean-ability of the pipelines is of fundamental importance. The well cleaned machine will neither contaminate the milk nor infect the cow udder.

The efficiency of pipeline cleaning is significantly improved by introducing air in the ducts and such way the cleaning time and the amount of cleaning liquid are reduced. If the intake air is mixed in the cleaning liquid there will be a higher velocity,

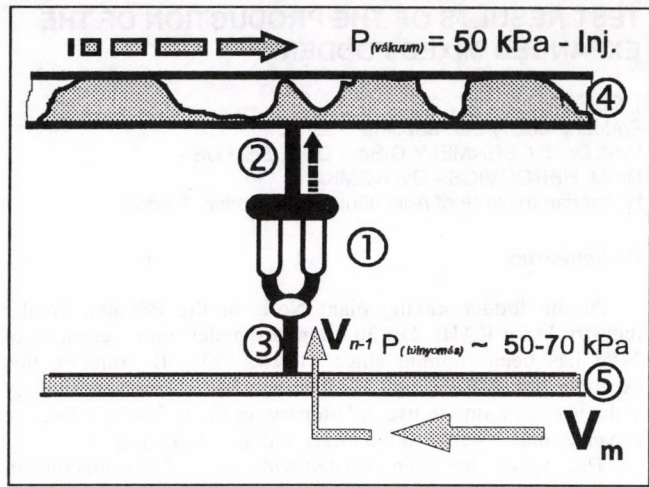

FIGURE 5

Combined injector washing

1- milking device; 2- connecting tube; 3- long milk duct;
4- washing duct; 5- milk duct;

V_m - flowing washing liquid volume; V_{n-1} - number of milking devices

intensively eddying flow in the tubes implying highly effective cleaning onto the tube walls.

The size increase of short and long milk ducts and collectors stabilises the milking vacuum. From the point of view of cleaning the controlled air intake is more advantageous. By the control, optimal conditions are reached even in quite varying circumstances, as for the cleaning liquid velocity and turbulence. In the case of larger milking devices (with longer and greater diameter pipelines) the combined injector cleaning is proposed. In this method one can adjust the following parameters as desired:

- volume of liquid
- chemical concentration
- cleaning duration

There is no doubt, that the technique exposes environmental benefits through the adjustability of these factors, also. (The waste amount and its storage cost and the environmental load is reduced, etc.)

TEST RESULTS OF THE PRODUCTION OF THE EXPANDED MIXED FODDER

I. CSIZMADIA
Fodder Industry Ltd, Bábolna
Prof. Dr. J. CSERMELY D.Sc. - Dr. Z. BELLUS -
Dr. M. HERDOVICS - Gy. KOMKA
Hungarian Institute of Agricultural Engineering, Gödöllő

Preliminaries

At the fodder mixing plant No.1. of the Bábolna Fodder Industry Ltd a KAHL OE 30.2 type expander with a capacity of 24t/h has been running since March, 1995. By running this expander the HTST (High Temperature Short Time) technology is the very first one in use in Hungary. In the technology line the expander unit is between the mixer and the press equipment.

The investor has been initiated wide range of examinations in terms of utilization of the expanded mixed fodder. In the scope of the examinations the Hungarian Institute of Agricultural Engineering was entrusted to test the influencing technological factors of the physical-mechanical features of the pellet made by this process.

Methods

Examinations of 13 psc of feed samples, taking from adjustment of different technological parameters, were achieved. Sampling points can be seen on fig. 1. Technological parameters were as follows: composition of the feed, moisture content, conditioning characteristics, amount of liquid components and their temperature, capacity and pressure of the expander, etc. Laboratory analyses comprised the moisture content, volumetric mass, mean grain size, inhomogeneity index and hardness measuring.

Boiler fattening experiments were also achieved by collaboration of the PATE, Kaposvár, feeding the chickens with expanded and granulated feed. During the fattening experiments special attention has been paid to the mean daily gain, the feed consumption and the results of killing.

Results

Some characteristic test results are emphasized. Changing of grain size of the feed from the basic fodder mixture through the expanded, crumbled and graded feed to the final product were examined in detail. Crushing was done at two kind of adjustent at the crumbler in so called fine and normal size. Results are summarized in table 1.

Table 1
Changing of grain size during the technology process

Sampling points	Adjustment of the crumbler			
	Fine		Normal	
	d ₅₀	U	d ₅₀	U
Mixture (M1)	0.80	4.2	0.81-0.96	3.0-4.7
Expanded feed (M2)	1.75	3.6	1.40-1.75	3.1-4.6
Crumbled pellet (M5)	1.55	3.9	1.80-3.25	3.7-5.1
Graded product (M6)	2.75	1.6	4.10-4.80	1.6-2.3
Final product (M7)	1.50	2.4	2.65-4.10	2.2-2.3

d₅₀ (mm): mean grain size,
U: inhomogeneity index (according to the MSz 15474)

As it can be seen from table 1. at fine adjustment of the crumbler the mean grain size of the pelleted and crumbled feed is almost the same. Though it can be improved by grading, but the grain size of the final product, owing to the considerable conveyance of materials, is near to the expanded feed. In this case using of the pelleting unit needs careful consideration at least.

At the normal adjustment of the crumbler, the mean grain size of the final product can be increased by twofold at least.

In the grader the dust of 0.58-0.67 mm mean grain size is separated. Mass of separated dust is 26-29 kg/min. Amount of dust is got back to the pre-storage bin of the expander and owing to it the effective output of the expander decreases by 8-18 %.

Depending on the parameters of expanding the stability of the pellets is also changing. In the case of producing two kind of feed the changing of abrasive resistance (PD index) and hardness against the temperature of the expanded material and the expanding pressure were tested.

In the first case increasing the material temperature in the expander the other parameters were also changed (capacity; amount of dosed water; material temperature in the conditioning auger), while the expanding pressure was near constant (9-10 bar). In this case the PD index and hardness of the pellets were also increased together with the increasing of the material temperature (See fig. 2), but while increasing of abrasive resistance was small (1.3 %), increasing of hardness was considerable (~25 %). During the test period the specific power consumption decreased considerably together with the increasing of the material temperature, while the power consumption of the pelleting unit was increased.

In the second case at a relatively constant expanding parameters, a considerable increasing of PD index against the expanding pressure could be observed (~5 %), while increasing of the pellet hardness was smaller (~14.5 %). As it can be seen in fig. 3 in this case the specific energy consumption of the expander was considerable, while the power consumption decreased to a less degree.

In that case when the pellet is crushed and crumbled immediately, better abrasive resistance of the pellet, better mean grain size of the final product and the rate of chippings have less importance. (For example if PD index is 9.07 at crumbling the d₅₀=3.25 mm and the fraction less than 1.0 mm is about 10 % while at PD index =8.54 the d₅₀=1.90 mm and the fraction less than 1.0 mm is about 20.0 %)

Favourable effects of the feed, producing by the new technological line, concerning the results of broiler fattening are shown in table 2. All the advantageous specific fodder consumption, the daily gain that was more than 10 % compared to the control stock, and the favourable killing results alike proved the reason for the existence of the new fodder processing technology.

Table 2
Broiler fattening test using expanded+granulated feed
(Kaposvár, 1995.)

Results of test	Control	Expanded + granulated	Index %
Mean daily gain (g)	43.70	49.60	113.50
Live weight at 42 nd days (g)	1 876	2 123	113.20
Mortality (pcs)	12	5	
Total feed consumption (g)	3 859	4 074	105.60
Specific feed consumption (kg/kg)	2.06	1.93	93.70

results results of killing:

	Control	Expanded + granulated	Index %
Weight of ready-to-cook (g) and Rate of weight of ready-to-cook /weight of killing (%)	1 152	1 320	114.60
Weight of chest + chicken leg (g) and Rate of weight of chest + chicken leg/weight of killing (%)	745	873	117.20
Abdominal fat (g) and Rate of abdominal fat/weight of killing (%)	40	45	
	2.30	2.30	

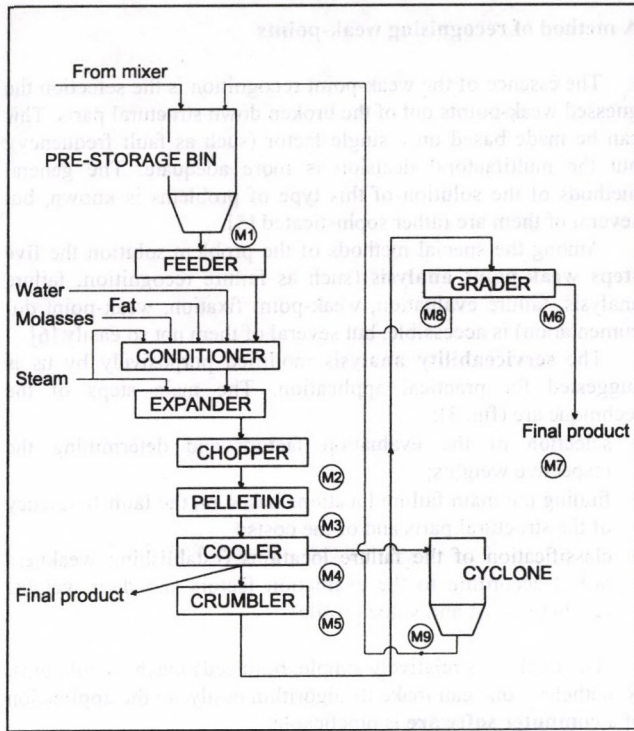

FIGURE 1

Process of the technology and the sampling points

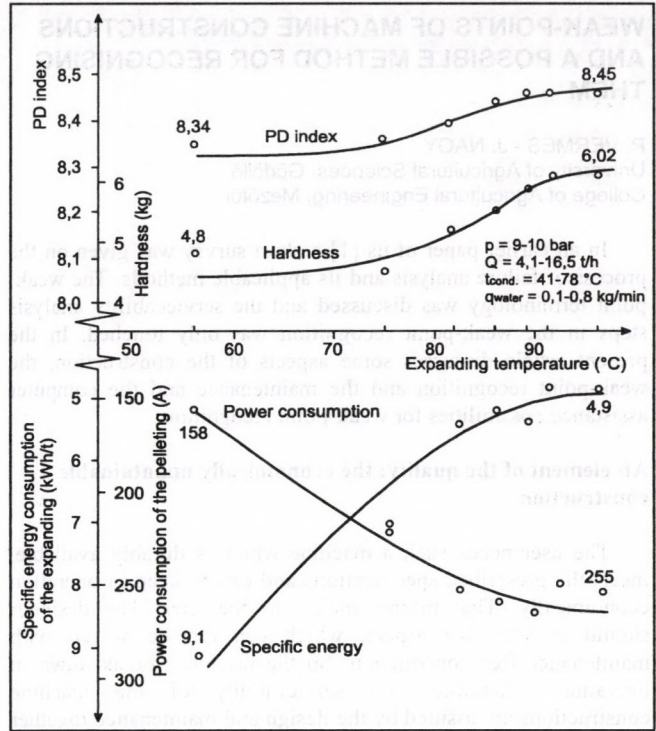

FIGURE 2

Stability of pellets and changing of capacity of the equipment plotted against the expanding temperature

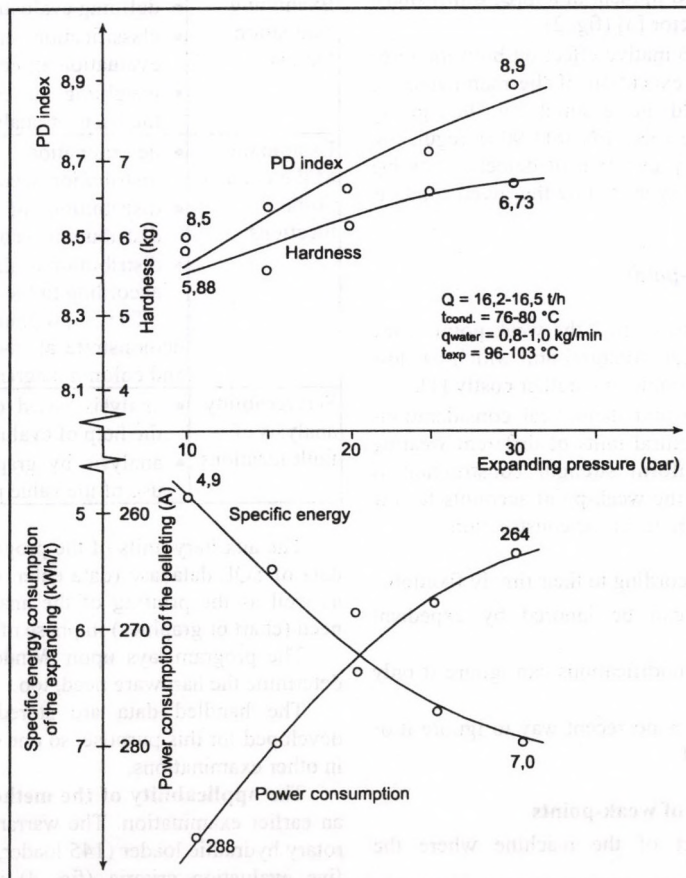

FIGURE 3

Stability of pellets and changing of capacity of the equipment plotted against the expanding pressure

WEAK-POINTS OF MACHINE CONSTRUCTIONS AND A POSSIBLE METHOD FOR RECOGNISING THEM

P. VERMES - J. NAGY
University of Agricultural Sciences, Gödöllő
College of Agricultural Engineering, Mezőtúr

In an earlier paper of us [1] a short survey was given on the process of failure analysis and its applicable methods. The weak-point terminology was discussed and the serviceability analysis steps in the weak-point recognition was only touched. In the present article discusses some aspects of the construction, the weak-point recognition and the maintenance and the computer assistance possibilities for weak-point recognition.

An element of the quality: the economically maintainable construction

The user needs such a machine which is durably available, meets the prescribed specifications and can be kept in operation economically. That means quality to the user. The designer should enforce that aspect, which can not be solved with maintenance free construction. So the machines break down in operation. Therefore, the serviceability of the machine constructions are assured by the design and maintenance together (fig. 1).

The quality requirements to the up-to-date production processes are enforced by the quality management. The TEEP (total effective equipment productivity) is applicable to an all-out characterisation of a production system (apparatus), which presents the applicability of the equipment in a three dimensional co-ordinate-system as a status vector [3] (fig. 2).

The maintenance has a determinative effect on both the three factors, therefore the controlled execution of the manufacturing and the other processes should be ensured by the quality assurance in accordance with the MSZ EN ISO 9001 regulation [4]. The requirement means the prevention of defects, avoiding the reduction of the wearing out spare below the given limit, as much as possible.

The characteristics of the weak-point

In the case of a machine construction the weak-point is the typical point of failure, or a critical structural unit which has low wearing out spare and that is restorable only rather costly [1].

According to the experience and theoretical considerations the machines are built from structural units of different wearing out spares, since a perfect uniform strength construction is impossible to be constructed. So the weak-point accounts for the relative technical level of the elements of the construction.

The types of the weak-points according to their timely fixation:

- **onfold weak-point:** which can be ignored by expedient measures definitively.
- **returning weak-point:** some modifications can ignore it only temporarily.
- **permanent weak-point:** there is no recent way to ignore it or the ignorance is not economical.

Some important characteristics of weak-points

- **Location:** the functional part of the machine where the maloperation occurs.
- **Intensity:** the measure of the effect of the weak-point (the maximum value is when damage is caused).
- **Potential of its:** the multiplication of the number of building elements and the sum of the possible faults.

A method of recognising weak-points

The essence of the weak-point recognition is the selection the guessed weak-points out of the broken down structural parts. This can be made based on a single factor (such as fault frequency), but the multifactorial decision is more adequate. The general methods of the solution of this type of problems is known, but several of them are rather sophisticated [5].

Among the special methods of the problem solution the **five steps weak-point analysis** (such as failure recognition, failure analysis, failure evaluation, weak-point fixation, weak-point documentation) is accessible, but several of them not so easily [6].

The **serviceability analysis** modified purposively by us is suggested for practical application. The main steps of the technique are (fig. 3):

- selection of the evaluation factors and determining the respective weights;
- finding the main failure locations based on the fault frequency of the structural parts and/or the costs;
- classification of the failure locations (establishing weakness order) according to the evaluation factors and their weights (evaluation list and value profile).

The method is relatively simple, but needs much calculations. Nonetheless, one can make its algorithm easily, so the application of a **computer software** is practicable.

The main parts of the elaborated program are as follows:

Program units	Activities
Examining evaluation factors	<ul style="list-style-type: none"> • defining evaluation aspects • classification, standardisation according to the evaluation aspects • weighting the evaluation factors selected on the basis of qualification limit value
Examination of the main failure locations	<ul style="list-style-type: none"> • determination of the failure frequency distribution according to the structural parts • distribution of the trouble shooting cost distribution according to the structural units • distribution of the specific (per one fault) cost according to the structural units. <p>The program gives possibility to demonstrate all the three examination by table and column diagram.</p>
Serviceability analysis of fault locations	<ul style="list-style-type: none"> • analysis based on table demonstration with the help of evaluation list • analysis by graphical demonstration making use of the value profile of structural units

The auxiliary units of the program ensure the handling of the data of SQL database (data enter, modification, deletion, query), as well as the printing of the analysis results meeting the user need (chart or graphics) in phase of the examination.

The program lays upon Windows 3.1 user interface, which determine the hardware need, too.

The handled data are stored in an SQL type database developed for this purpose, so one can query and process the data in other examinations.

The **applicability of the method** was verified by the data of an earlier examination. The warranty time fault of a pulled type rotary hydraulic loader (145 loader, 354 faults was analysed upon five evaluation criteria (fig. 4) including six structural units which were selected on the basis of failure frequency (fig. 5) and repair cost (fig. 6).

The final result is shown by the **value profiles** of the main fault locations (fig. 7): The weak point is found at the low (small

total value) and wide (great weight factor) band. And it is important that the value profile should be balanced. The weakness order is shown in the figure.

References

[1] VERMES, P.: Recognition and correction of machine design weak points = Hungarian Agricultural Engineering N° 7/1994. p. 57-58.
 [2] MARTINEAU, G.: Maintenance et pradoxes de l'évolution technique = Enjeux, (52) 1984. nov. p. 51-54.
 [3] NIEMEIER, F. - REDEKER, G.: Produktionsprozesse umfassender beurteilen = Qualität und Zuverlässigkeit, 40. (12) 1995. p. 1424-1426.

[4] PERJÉSI, A. - SÁNDOR, P.: Az ISO 9001 szabvány követelményeinek megfelelő karbantartási rendszer kiépítése és működtetése = Gépgyártástechnológia, XXXVI. évf. 1996. ápr. 4. sz. p. 40-43. (Building up and operating maintenance system meeting the ISO 9001 regulation, in Hungarian)
 [5] KINDLER, J. - PAPP, O.: Komplex rendszerek vizsgálata. Műszaki Könyvkiadó. Budapest, 1977. p. 262 (Testing complex systems, in Hungaraian)
 [6] Instandhaltungsorientierte Schwachstellenanalyse = VDI Fortschritt-berichte, Reihe 2. Fertigungstechnik, 1993. N° 243. p. 53-61.
 [7] PAHL, G. - BEITZ, N.: A géptervezés elmélete és gyakorlata. Műszaki Könyvkiadó. Budapest, 1981. p. 466 (Theory and practice of machine design, in Hungarian)

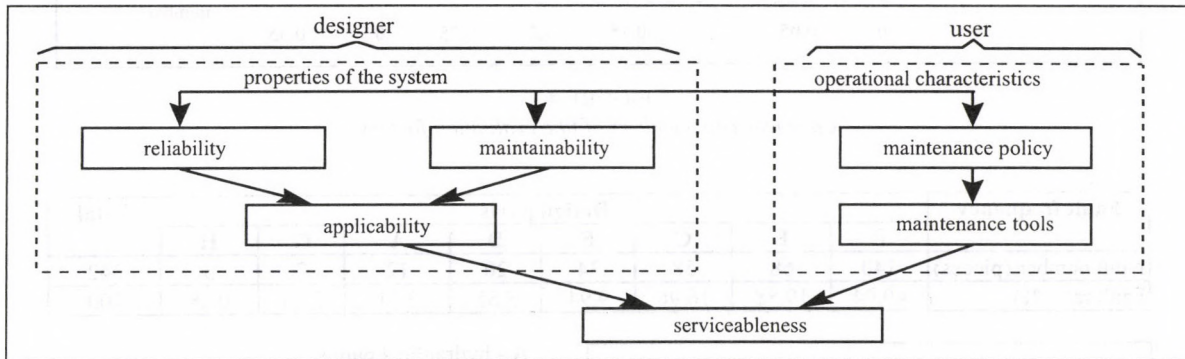

FIGURE 1 Relationships of the factors determining serviceableness [2]

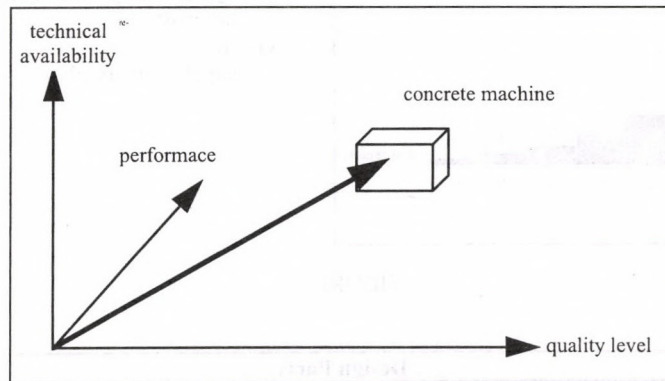

FIGURE 2 Effectivity of a machine in a three dimensional coordinate system

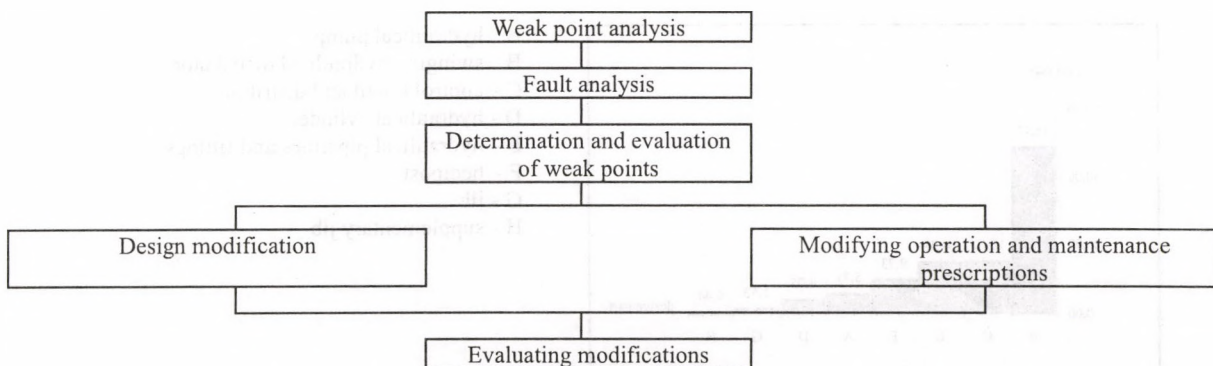

FIGURE 3 The process of weak point correction simplified

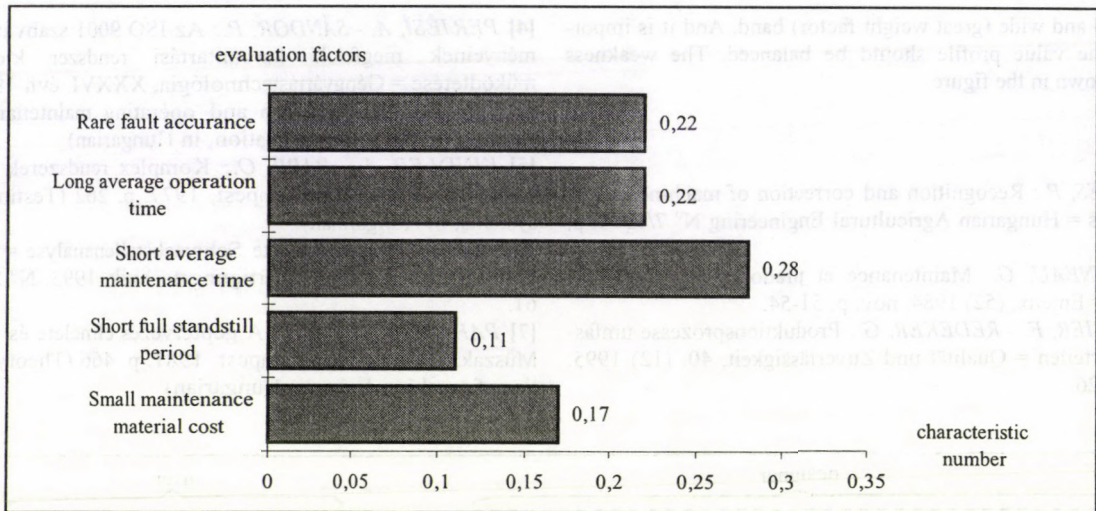
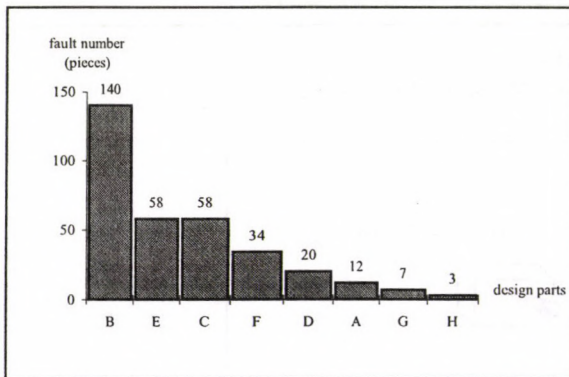

FIGURE 4
Characteristic numbers of the evaluation factors

Fault frequency	Design parts								Total
	B	E	C	F	D	A	G	H	
Fault number (pieces)	140	68	58	34	20	12	7	3	342
Fault rate (%)	40.94	19.88	16.96	9.94	5.85	3.51	2.05	0.88	100



- A - hydraulical pump
- B - swinging hydraulical distributor
- C - control board and distributor
- D - hydraulical cylinder
- E - hydraulical pipelines and fittings
- F - heelpost
- G - jib
- H - supplementary jib

FIGURE 5

Costs	Design Parts								Total
	B	C	E	F	A	D	G	H	
Value (Ft)	494641	152975	149981	98814	57966	41074	15458	4424	1015333
Rate (%)	48.72	15.07	14.77	9.73	5.71	4.05	1.52	0.44	100

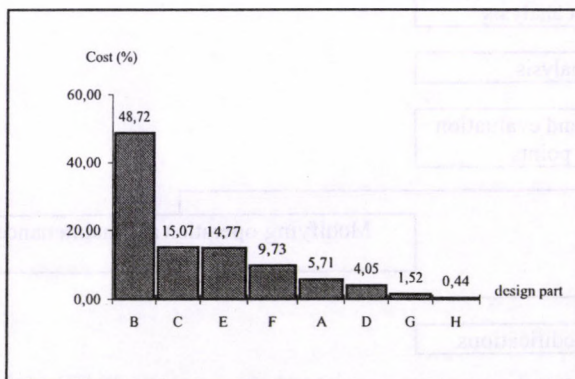

- A - hydraulical pump
- B - swinging hydraulical distributor
- C - control board and distributor
- D - hydraulical cylinder
- E - hydraulical pipelines and fittings
- F - heelpost
- G - jib
- H - supplementary jib

FIGURE 6

Design part identifier	A	B	C	D	E	F
Hierarchic order of weakvers	6	1	3	5	4	2
Fault frequency	10 8 6 4 2	10 8 6 4 2	10 8 6 4 2	10 8 6 4 2	10 8 6 4 2	10 8 6 4 2
Average operation time	10 8 6 4 2	10 8 6 4 2	10 8 6 4 2	10 8 6 4 2	10 8 6 4 2	10 8 6 4 2
Average maintenance time	10 8 6 4 2	10 8 6 4 2	10 8 6 4 2	10 8 6 4 2	10 8 6 4 2	10 8 6 4 2
Average full standstill period	10 8 6 4 2	10 8 6 4 2	10 8 6 4 2	10 8 6 4 2	10 8 6 4 2	10 8 6 4 2
Average maintenance material cost	10 8 6 4 2	10 8 6 4 2	10 8 6 4 2	10 8 6 4 2	10 8 6 4 2	10 8 6 4 2

Design parts

- A - hydraulical pump
- B - swinging hydraulical distributor
- C - control board and distributor
- D - hydraulical cylinder
- E - hydraulical pipelines and fittings
- F - heelpost
- G - jib
- H - supplementary jib

FIGURE 7
Value profile (hydraulical swinging loader)

HOW TO COLLECT AND EVALUATE MEASURED DATA BY MATHEMATICA?

L. OROVA Dr.
University of Agricultural Sciences, Gödöllő

The fact that a human being does not like to make routine tasks led to the quick development of computer science. The collection, registration and evaluation of large number of measured data are the day-to-day work of engineers, agronomists, biologists, etc. Their work cannot dispense with the computers. Although most of the programs are able to do statistics to some extent it may be interesting how to process data with a software of symbolic mathematical operations, with *Mathematica*.

It has a great number of built-in functions (the 2.1 version of *Mathematica* has nearly 2000 of it), to solve complicated problems by typing only a few rows of commands. The range of the process can naturally be completed up to the requirements, but a great number of important functions of statistics are collected into the program package **Statistics**.

Ways of collecting measured data by Mathematica

– The most obvious way to input data into *Mathematica* is typing, but it takes a long time and there are great possibilities to make mistakes during both the reading data of measure instrument and typing.

– If the computer directly gets the measure signal after proper digitalisation, the sources of errors caused by chance can be minimised. These signals can be saved in files, for example in text files or in binary files which requires less storage capacity. Data from both types of files can be loaded to *Mathematica*, binary files by the package of **Utilities** `'BinaryFiles'`.

– *Mathematica* follows many software standards that allow to exchange material with other programs. It can read data in various formats, and can generate output for systems such as C, FORTRAN, TEX. *Mathematica* can communicate at a high level with other programs using the **MathLink** communication standard, for example the way to communicate with EXCEL is by **MathLink for Excel**.

Evaluating measured data

Data are arranged in lists by *Mathematica* without respect of the input way. Several procedures help to handle data in lists. **Statistics** `'DataManipulation'` package provides an extension of the list manipulation functions that are built-in to *Mathematica*. Additional functions useful for manipulating statistical data include frequency counting and computing cumulative sums.

Data can be viewed in two or three dimensional graphics. Graphics of high level can be made by **Graphics** program-package.

There are several built in procedures for statistical distributions, tests, fittings, etc. in the packages of **Statistics**.

Important packages of **Statistics** are `'ContinuousDistribution'`, `'DiscreteDistributions'`, `'LinearRegression'`, `'ConfidenceIntervals'`, `'HypothesisTests'`, `'DescriptiveStatistics'`, and `'MovingAverage'`. The names refer to the content of the packages.

Examples

Reading data into Mathematica

Platinum sensors connected with a computer measure temperature. The analogue electrical signal is converted into a series of electrical pulses by an A/D converter with 8 channels adapted to the computer. The number of the channel, the time and value of measured temperatures are stored in a text file. *Mathematica* opens the file for reading, reads the data into a list,

selects the data of channel no. 1 and represents the data in two dimensional graphics. (Notation: *Mathematica* input, output)

```
o=OpenRead["b:\meresp.txt"];
measureddata=ReadList[o,{Number,Number,Number}];
firstchannel=measureddata[[Table[8-i-7,{i,20}]]];
```

The view of the measured data:

```
ListPlot[Map[Drop[#,1]&,firstchannel],
AxesLabel->{time[s],temperature[°C]}]
```

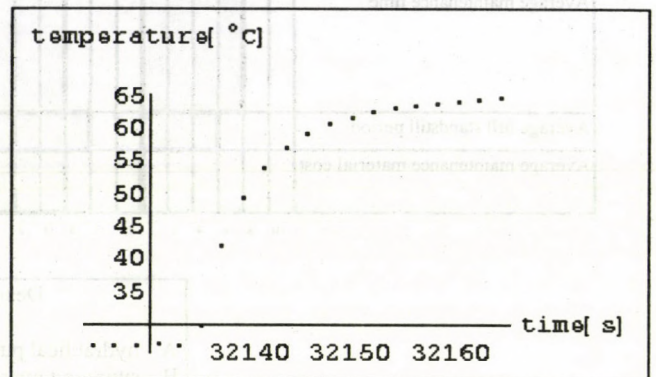

Interpolation and normal distribution

The list named *tens* contains the result of measuring the tensile strength of a steel no. A 50.

The questions are the following:

- Are the data normally distributed?
- What is the mean?
- How many are the estimated value of trash, if the material of 485 N/mm² tensile strength is considered to be trash?

The measured data [N/mm²]:

```
tens = {506,470,481,483,512,490,492,493,494,495,
496,498,499,500,491,501,502,528,503,504,
506,507,508,509,488,514,515,497,516,529};
```

a) Determination of the frequency histogram of data in the groups of every 10 N/mm²

It is possible to get quickly a chart of bars with the help of the program packages **Statistics** `'DataManipulation'` and **Graphics** `'Graphics'`:

```
<<Statistics`DataManipulation`
<<Graphics`Graphics`
freq=BinCounts[tens, {Min[tens]-1,Max[tens],10}];
ch1=BarChart[freq]
```

There are more steps to get not only the histogram, but the interpolating curve of the points of histogram too.

Steps: determination of the number of measurements, ordering data into ascending order, sorting data into sections, determination of the number of sections and that of the frequent assurance of data in the sections. The loaded *DataManipulation* and the *Graphics* program packages are used here too. (Only the final charts are presented.)

```
n=Length[tens];ord=Ordering[tens];k=tens[[ord]];
c=BinLists[k,{Min[k]-1,Max[k],10}];
j=(Max[k]-(Min[k]-1))/10;
freq1=Table[Length[Part[c,i]],{i,1,j,1}];
```

```
ch2=BarChart[Transpose[{freq1,Range[474,530,10]}],
AxesLabel->{tensile,frequency}]
```

```
tens1=Table[Min[k]+5*i,{i,1,j,1}];
freq2=Table[{tens1[[i]],freq1[[i]]},{i,1,j,1}];
freqi=Interpolation[freq2];
```

```
ch3=Plot[Evaluate[freqi[x]],{x,460,520},
AxesLabel->{tensile,frequency}]
Show[GraphicsArray[{ch2, ch3}]]
```

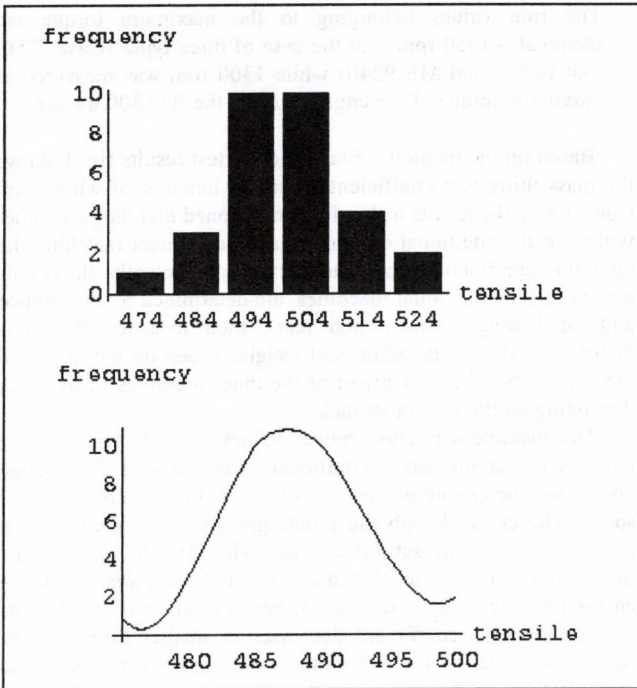

The curve is similar to that of normal distribution, but it shows a typical error due to interpolation at ends of the intervals.

b) The mean, the standard deviations (divided by n, n-1) of the list

```
<<Statistics`DescriptiveStatistics`
{m=N[Mean[k]],s=N[StandardDeviationMLE[k]],
sk=N[StandardDeviation[k]]}
{500.9, 12.6448, 12.8609}
```

c) The built in function of normal distribution, the probability density function and the cumulative distribution function of distribution

```
<<Statistics`NormalDistribution`
g=NormalDistribution[m,s];
sf=Plot[N[PDF[g,x]],{x,450,550}]
Plot[CDF[g,x],{x,450,550}]
```

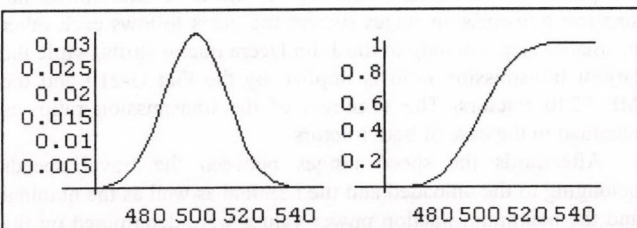

d) The probability of trash is the value of distribution at 485:

```
CDF[g,485]
0.1096097201617381
```

Thus the probability of trash is approximately 10.9% in by normal distribution.

Regression and analysis of fitting

Determination of the connection of slip with the moment by measuring moment and the revolution per min. (Measured by L. Káta)

The measured data, fitting a second order function by the theory of least squares, using statistical package to get not only the fitting function, but the analysing of fitting too

```
ms={{1.4,0.66},{13.8,2.04},{18.5,3.14},
{19.8,3.92},{21.2,4.42},{24.9,5.69}};
k1=Fit[ms,{x^2,x,1},x];
<<Statistics`LinearRegression`
N[Regression[ms,{x^2,x,1},x],3]
```

{ParameterTable ->

	Estimate	SE	Tstat	PValue
x^2	0.00943	0.00138	6.82	0.00644
x	-0.0303	0.0358	-0.847	0.459
1.	0.676	0.205	3.29	0.046

RSquared -> 0.994, AdjustedRSquared -> 0.99,

EstimatedVariance -> 0.0304,

ANOVATable ->

	DoF	SoS	MeanSS	Fratio	PValue}
Model	2.	15.8	7.92	261.	0.000432
Error	3.	0.0911	0.0304		
Total	5.	15.9			

The ParameterTable contains the estimate of the coefficients of the second and first degree parts and of the constant, their standard error, the value of t and the probability value in the case of t-test. (Regression is significant on the second order part and on the constant.) The ANOVATable is an analyse of variance table, it includes F-ratio tests for comparing the models specified in the function, as well as the degrees of freedom and sums of squares used to obtain these F ratios. (F=261 is much larger than the value of significant regression what is usually 2.5)

The measured data and the curve of regression:

```
a1=ListPlot[ms,PlotStyle->PointSize[0.02]];
a2=Plot[k1,{x,0,25}];
Show[a1,a2]
```

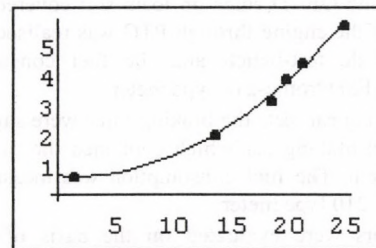

It seems to be a proper regression by the graphics too.

References

[1] BLACHMAN, N.: Mathematica Quick Reference, Addison-Wesley Publishing Company, New York, 1992.

Acknowledgement

The present work has partially been supported by grant No. MKM 419. of the Hungarian Ministry of Education and Culture.

TEST RESULTS OF 150-200 KW POWER OUTPUT HEAVY UNIVERSAL TRACTORS

Dr. M. SZENTE

Hungarian Institute of Agricultural Engineering, Gödöllő

Dr. I.J. JÓRI

Technical University, Budapest

For the Hungarian agricultural production the modernisation of the tillage aim high performance power machine stock has a great importance. That should not mean only the replacement of the existing power machine fleet with new machines but technical development, too. The aim of the production efficiency and economy imply new and greater requirements to the power machines of the basic tillage, as well. Taking those requirements also into consideration one has to establish new system of higher requisites such as proper performance, economy, low specific consumption, environment friendly engine, powershift transmission gear the attachability of the existing implements of RÁBA 250 tractors, favourable energetic operation, electrohydraulic control of lifting equipment.

Based on the international experiences and offers those are the so called superheavy universal tractors. They are characterised by the large mass (10-12 tons) and the matching ample power engine (150-200 kW). Their auxiliary front wheel drive and controlled hydraulic lifting device makes even possible the more economic operation of the heavy tillage machines constructed traditionally for the mere soil cultivation purpose four wheels driven tractors with no control lifting device.

The Rába Steiger (245/250) tractors can be considered the basic type in this country. Considering the available type variety and the conditions the following tractor types were selected in order to know and test them for replacing Rába Steigers: Case 7250, Fiat G-210, John Deere 8300 and Massey Ferguson 9240. The tractors included in the examinations were selected by their dealers and they or other professional representatives of the manufacturers were also present at the test-bench and field traction tests. In the examination site they followed up and approved the test-bench results.

The test-bench and the field tests were carried out in the area of Farmer Ltd., Balatonszabadi. The tests were accomplished between July 10 and July 30, 1995. The preparation and adjustment of the tractors (fitting extra weight) for the tests were made by the dealers.

The engine tests were made in accordance with the OECD prescriptions, braking the PTO. The traction characteristics were recorded meeting OECD rules on loam soil covered by stubble. The loading of the engine through PTO was realised by an AW-400 type mobile test-bench and the fuel consumption was measured by a Flowtronic-210 type meter.

In the braking car tests the braking force were supplied by the own assembled braking car which contained the measuring and recording system. The fuel consumption was measured also by the Flowtronic-210 type meter.

The tractors were evaluated on the basis of engine and traction tests. As the result of the evaluation of engine characteristics determined by PTO braking tests (table 1) it is stated as follows:

- Both the nominal and highest value of maximum engine power are exposed by the engine built in the Case 7250 type tractor. The order of the other tractors is JD 8300, MF 9240 and Fiat G-210.
- The best specific fuel consumption was implied by the JD 8300 and the Case 7250 tractors. The difference between the two types could be found in some points for the one and in the other points for the other. The difference did not exceeded

0.7-1.8 %. As for the other two types, the engine built in the Fiat G-210 tractor exhibited a specific fuel consumption 3.7-5.5 % higher compared to the former two types, while the engine of the Massey Ferguson 9240 type tractor characteristics are less favourable by 5.1-7.6 %.

- The engine flexibility coefficients were compared through the torque values belonging to the nominal rpm given by the manufacturer. The engine of the Fiat G-210 tractor has the greatest flexibility and the order of the others is JD 8300, Case 7250 and MF 9240.
- The rpm values belonging to the maximum torque are identical - 1550 rpm - in the case of three types (Case 7250, Fiat G-210 and MF 9240) while 1300 rpm was measured at maximum torque of the engine built in the JD 8300 tractor.

Based on the traction - braking car - test results fig. 1 shows the mass utilisation coefficient values as function of wheel slip. Considering the results it should be mentioned that they are rather typical to the additional equipment and adjustment matching the operation conditions than to the tractor type. Actually, the results gained for the individual machines are determined by the applied additional weights (front and rear), their measure, the mass distribution due to the additional weights (mass on the front and the rear axles), the adjustment of the inner pressures of the tyres depending on the load or its lack.

The maximum traction power values in each gear and the relevant power utilisation coefficients (the ratio of the traction power and the engine power) are shown as function of the travel speed. The curve though the points gives the so called traction power (or power utilisation) envelope (fig. 2). The results draw the attention to the fact that the load of the tractors should be ensured by the raise of the speed, because one can see that the power utilisation coefficient decreases in smaller extent on the right hand side of the optimum speed range with the speed increase than on the opposite side, which is session of the great traction force need.

The optimum gear ranges of the individual tractors from energetic aspect were separately determined and shown in the table and figure (table 2, fig. 3). The optimum speed range of the Case 7250 and the MF 9240 tractors were found at higher speed values than that of the Fiat G-210 and the JD 8300 tractors. The reason for it is the smaller power-mass value i.e. the relatively high engine power compared to the mass.

Taking into account all of these, one can state that the utilisation of the higher power engines built in the Case 7250 and MF 9240 tractors can not be increased by increasing the speed any more, since the increased speed values are outside the speed range of the agrotechnology optimum.

In the evaluation of the traction properties the examination of the speed distribution and speed stages is important because it influences decisively the compatibility to the implements.

In the evaluation first the travel speed values of the machine specification charts belonging to the nominal engine speed were compared to each other (table 3). As the table data shows the smallest transmission stages (where the gears follows each other in smaller steps) belong to the John Deere tractor shifts, while the largest transmission ratio is implied by the Fiat G-210 and the MF 9240 tractors. The evenness of the transmission ratios is identical in the case of both tractors.

Afterwards the speed ranges between the travel speeds belonging to the unloaded and the nominal as well as the nominal and the maximum traction power values were determined on the basis of traction tests. As an example the results of the Case 7250 tractor type are shown in fig. 4.

Taking into account the structure, technical specifications and the practical requirement of the tractors, one can state that the

heavy universal tractors are mainly utilised in the plant production. Considering the home natural and soil conditions and the share of economically produced plants the application fields of the heavy universal tractors can be multiple of that of the Rába-Steiger tractors. The heavy universal tractors can be used in the following operations:

- tillage
- fertiliser and chemical application
- seeding
- plant treatment and care
- harvest.

Among the operations listed above first of all the tillage utilising the traction ability and the seeding, fertiliser and chemical application and mass fodder harvest which need the PTO driving in several cases can produce the suitable load and so the proper and economical utilisation of the tractors.

The plant care works - in the case of suitable tyres and track - can be taken into account because the tractors can not be used for any other purpose that time.

In the selection of the implements and the formulation of aggregates of the heavy universal tractors geometrical, hydraulic, energetic and technology aspects play decisive role.

The energetic of matching the tractor and the implements to each other has been begun at both of the four types. Due to the time and cost available, the matching has been made only for loam soil stubble field making use of the field test results of the implements and those of some other similar measurements.

The bias points reached with different implements show no significant difference due to the similar technology and power parameters of the tractors. In the examined cases only the Rába-IH-10-14-9 type suspended moderately deep scuffler (of 50 cm working depth) is which can not be matched to any tractor with the expected result.

The results and experience with the high performance heavy universal tractors are summarised as follows:

- Case 7250, Fiat G-210, John Deere 8300, Massey Ferguson 9240 type heavy universal tractors were involved in the field tests and they all are applicable to substitute or replace the Rába Steiger (Rába-250) tractors;

- The tractors should be supplied with additional weight for the economic and efficient operation. Its extent depend on the pulling force demand of the connected implement and the process to be carried out;
- The great engine flexibility and the powershift property make possible to operate the implements with the most productive speed, as well as the most economically;
- The most machine types of implement aggregates of the Rába Steiger (Rába-250) tractors can be well applied with the new tractors but some problems of matching can occur;
- However, to utilise the universal properties of the tractors it is unconditionally necessary to widen the home implement stock (by home development or importing), aimed PTO driven, combined operation, multifunctional application types in addition to the conventional implements;
- The knowledge about the economical operation of heavy universal tractors - due to the novelty of the construction - is not yet complete and they are not advisable to be adapted because the operation conditions are different.

On the basis of the obtained results and experience the followings are proposed:

- The test of the European types (Fendt Favorit 824, 822 ...) in order to make the knowledge of heavy universal tractors complete;
- The comparative tests of the heavy universal and rubber track chassis tractors in the interest of choosing the tractors applicable to substitute Rába Steiger (Rába 250) types;
- Accelerating the development of the machine combinations and extending their purchase possibilities in order to utilise the new type power machines;
- The connection, energetic and working quality examination of the new aggregates and machine combinations, for successful operational information.
- The determination of the operational conditions (yearly possibly utilisation, farm size, etc.) of the heavy universal tractors.

Table 1
Test results of engines built in the tractors, PTO braking

		Tractor type			
		Case 7250	Fiat G-210	JD 8300	MF 9240
Maximum idle engine speed	rpm	2468	2275	2315	2425
Rated engine speed	rpm	2325	2150	2260	2300
Engine speed at max. performance	rpm	2025	1810	2010	2125
Engine speed at max. torque	rpm	1550	1550	1300	1550
Rated power	kW	167.0	130.0	162.8	152.5
Maximum power	kW	197.6	155.0	178.5	170.5
Power at rated engine speed specified by the manufacturer	kW	190.0	136.3	164.0	167.5
Maximum engine torque	Nm	1047	870	977	893
Specific fuel consumption	g/kWh				
- at rated power		238.5	245.5	236.6	252.5
- at maximum power		220.5	228.1	216.6	233.0
- at manufacturer specified rated power		228.3	241.0	230.0	240.0
Engine flexibility factor	Nm/Nm				
- calculated with the torque belonging to the measured rated power		1.53	1.50	1.42	1.41
- calculated with the torque belonging to the manufacturer specified rated engine speed		1.27	1.40	1.372	1.228

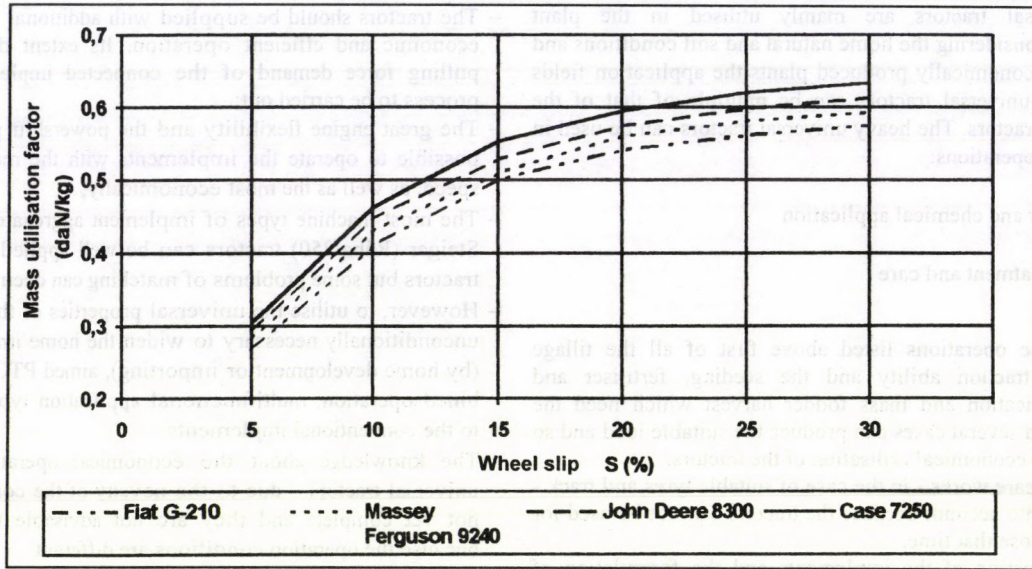

FIGURE 1
Diagram of mass utilisation factor versus wheel slip

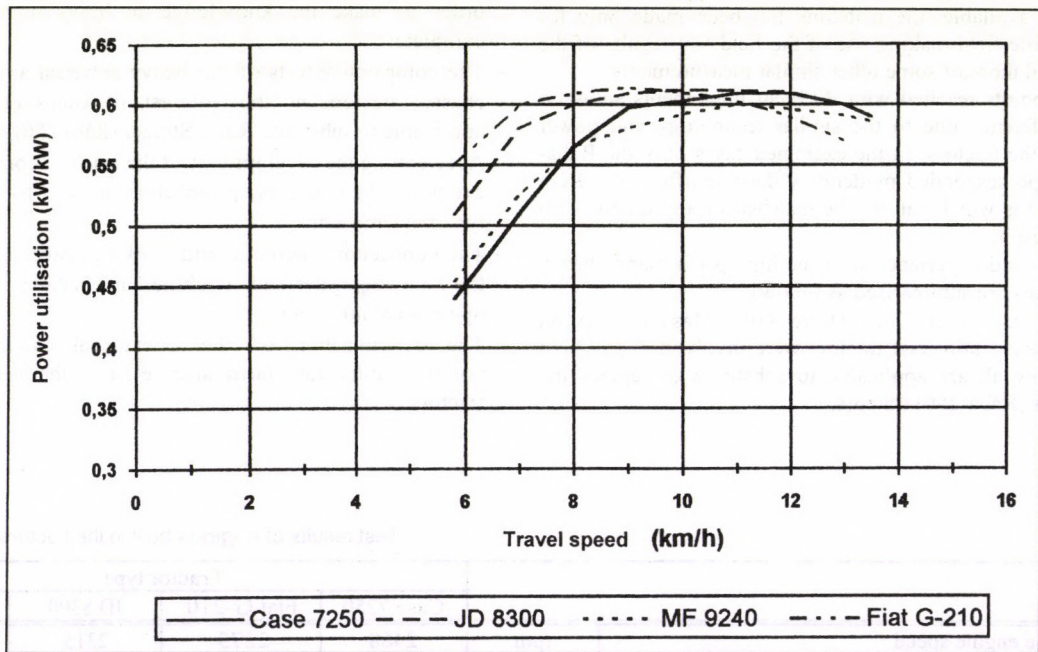

FIGURE 2
Envelopes of power utilisation versus travel speed

Table 2
Energetic optimum speed ranges

Tractor type	Optimum speed range (km/h)
Case 7250	9 - 13
Fiat G-210	7 - 11
John Deere 8300	7.5 - 12
Massey Ferguson 9420	8.5 - 13

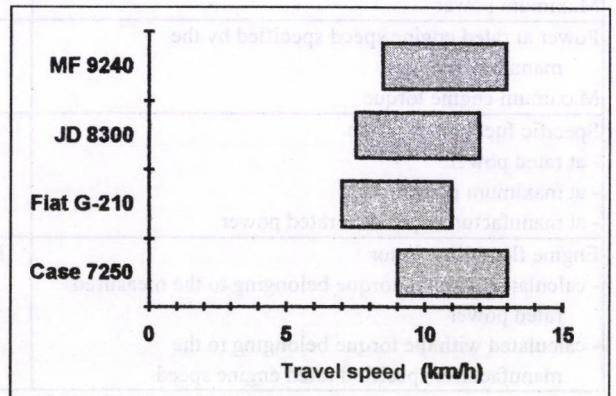

FIGURE 3
Energetic optimum speed ranges (dashed line is for showing agrotechnical optimum speed ranges)

Table 3
Travel speeds at rated engine speed

Gear shift	Tractor type							
	Case 7250		Fiat G-210		John Deere 8300		Massey Ferguson 9240	
	travel speed (km/h)	transmission ratio of sub-subsequent grades	travel speed (km/h)	transmission ratio of sub-subsequent grades	travel speed (km/h)	transmission ratio of sub-subsequent grades	travel speed (km/h)	transmission ratio of sub-subsequent grades
5	5.4	1.148	5.2	1.169	5.6	1.125	4.7	1.17
6	6.2	1.161	6.08	1.177	6.3	1.142	5.5	1.18
7	7.2	1.139	7.6	1.181	7.2	1.125	6.5	1.17
8	8.2	1.158	8.46	1.17	8.1	1.123	7.6	1.18
9	9.5	1.147	9.9	1.16	9.1	1.132	9.0	1.155
10	10.9	1.146	11.5	1.18	10.3	1.136	10.4	1.18
11	12.5		13.6		11.7	1.128	12.3	
12					13.2			

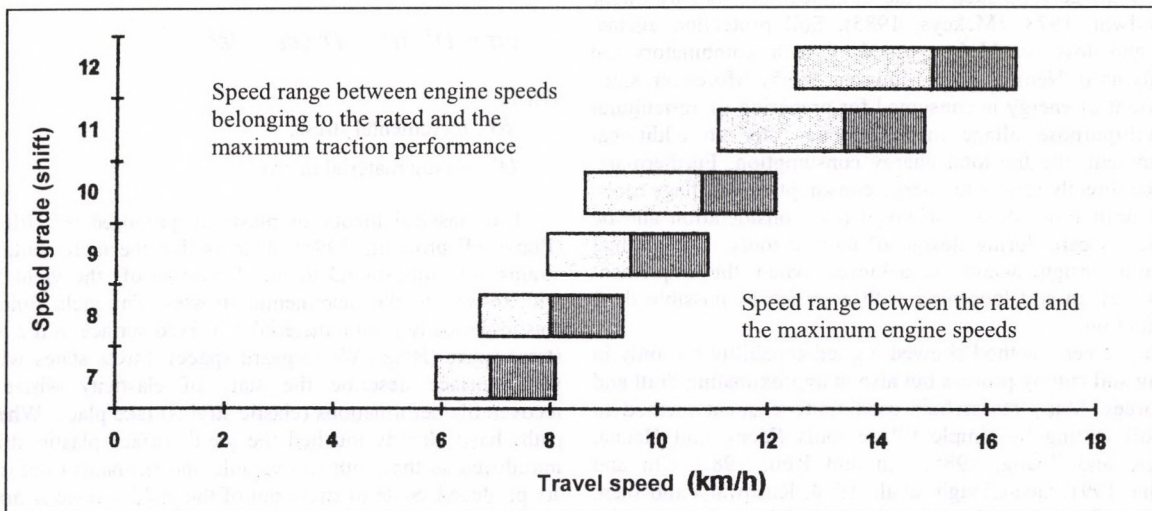

FIGURE 4
Shift and speed distribution of Case IH 7250 type tractor on loam soil stubble

TWO-DIMENSIONAL FINITE ELEMENT ANALYSIS OF SOIL CUTTING BY MEDIUM SUBSOILER

ABDUL MOUNEM MOUAZEN - Dr. M. NEMÉNYI
Pannon Agricultural University, Mosonmagyaróvár

Abstract

Two-dimensional finite element model was developed by which the work done by medium subsoiler was simulated. Loosening of sandy soil was investigated not only by the shank and chisel of the subsoiler separately, but also with both together. The soil was considered as nonlinear elastic-perfectly plastic material. By the constructed model, the loosening of layered agricultural soils can be assessed (e. g. loosening of a hard pan that generally results from repeatedly applying of mouldboard plow or disc harrow at same cultivating depth).

Introduction

Soil loosening due to the lifting act of tillage tools has widely spread as a reduced tillage practice during the last two decades. The matter of fact that soil degradation owing to extensive cultivation regimes has recently pushed to alleviate soil inverting and replace it, in many cases, by soil lifting tillage types. However, soil lifting by chisels and subsoilers can be combined with other tillage sorts such as the designed subsoiler by Spoor and Goodwin, 1978. (Mckey, 1985). Soil protection against erosion and loss would be gained if such combinators are practically used (Neményi, and Mouazen, 1995). Moreover, since high amount of energy is consumed for preparing of agricultural soils, multipurpose tillage machines can offer an additional benefit in reducing the total energy consumption. Furthermore, draft force directly relates to energy consumption of tillage tools. Therefore draft force should be taken into consideration and be given special care during design of cutting tools. The optimal tillage tool design would be achieved when the implement performs well in soil loosening with as much as possible draft force reduction.

Finite element method showed a good capability not only in modelling soil cutting process but also in approximating draft and lifting forces. Many researchers used finite element method to model soil cutting by simple tillage tools (Yong and Hanna, 1977; Xie and Zhang, 1985; Liu and Hou, 1985; Chi and Kushwaha, 1991; Gee-Clough, et al., 1994; Kushwaha and shen, 1995). Very few papers, however, have modeled soil cutting by lifting tillage tools (chisels or subsoilers) using finite element method. Araya and Gao, 1995. have developed 3-dimensional finite element model of soil cutting by subsoiler with air pressure. Their estimations of draft force and soil rupture dimensions showed a good agreement with the measured one by soil test (soil bin).

Objectives

Since the geometry of the cutting edge of different subsoilers are relatively complex, a successful construction of a soil cutting finite element model by a given subsoiler is highly complex specially during the specification of the interaction between two discontinuous bodies (soil and subsoiler). The objectives of this study are:

- 1- To develop finite element model of soil cutting by medium-deep subsoiler.
- 2- To predict draft force needed to draw the proposal subsoiler.
- 3- To develop visual simulation of soil loosening by means of plotting and calculating soil volume change as soil loosening indicator.

The results obtained from the finite element model were compared with the results from soil bin that were reported by former researchers using the same sandy soil of the same soil properties.

Procedure

Mechanical principles of elastic-perfectly plastic material behaviours:

Agricultural soils, as bulk materials, suffer plastic deformations after a given external load. Hence the resulted strain rates can be divided into elastic and plastic, considering the soil as elastoplastic material as;

$$d\epsilon = d\epsilon^e + d\epsilon^p$$

Where

$d\epsilon$: incremental total strain,

$d\epsilon^e$: incremental elastic strain, and

$d\epsilon^p$: incremental plastic strain.

According to the generalized Hook's law of elasticity, the incremental elastic strain can be related to the incremental stress as:

$$d\sigma = D^e \cdot d\epsilon^e = D^e (d\epsilon - d\epsilon^p)$$

Where:

$d\sigma$: incremental stress,

D^e : elastic material matrix.

The classical theory of plasticity proposed by Hill (1950), (Plaxis FE program, 1994), denotes that the incremental plastic strains are proportional to the derivative of the yield function with respect to the incremental stresses. The yield function for elastic-perfectly plastic material is a fixed surface in the principal stress space (Haigh-Westergaard space). Stress states within the yield surface describe the state of elasticity where purely recoverable deformations (elastic strains) take place. When stress paths have already touched the yield surface plastic strains are introduced so that both recoverable and permanent deformations are produced. State of stress out of the yield surface is practically impossible. This definition of the incremental plastic strain is designated as associated plasticity. Another definition of the incremental plastic strain, is to introduce an additional yield function called the plastic potential function. This procedure aims, however, to protect the model from being overpredicted of dilatancy. The plastic potential function confines a surface in principal stress space like the yield function. The mathematical determination of incremental plastic strain is:

$$d\epsilon^p = \lambda \frac{\partial f}{\partial \sigma}$$

Where

f : yield surface in the principal stress space,

λ : plastic multiplier.

The multiplier of plasticity equals zero when the stress state sites within the space enclosed by the yield surface and the soil is still under elastic deformations. While its value becomes higher than zero when plastic strains arise in a soil body. An incorporated status of both is called elastoplasticity under which the total incremental strain could be written as a function of incremental stress as:

$$d\sigma = \left(D^e - \frac{1}{d} D^e \frac{\partial g}{\partial \sigma} \cdot \frac{\partial f}{\partial \sigma} D^e \right) d\varepsilon$$

$$d = \left(\frac{\partial f}{\partial \sigma} D^e \frac{\partial g}{\partial \sigma} \right)$$

Where
g: plastic potential function.

The finite element program used is COSMOS/M 1.71. Druker-Prager elastic perfectly plastic model was utilized whose yield function is given as:

$$f = 3\alpha\sigma_m + \bar{\sigma} - K = 0$$

Where
 α , K: material parameters,
 σ_m : is the mean principal stress that can be expressed mathematically as:

$$\sigma_m = \frac{1}{3} I_1 = \frac{1}{3} (\sigma_x + \sigma_y + \sigma_z)$$

$\bar{\sigma}$ is the effective stress which might be related with the second deviatoric stress invariant as:

$$\bar{\sigma} = J_2^{1/2}$$

Where
$$J_2 = \frac{1}{2} \left[(\sigma_x - \sigma_m)^2 + (\sigma_y - \sigma_m)^2 + (\sigma_z - \sigma_m)^2 \right] + \tau_{xy}^2 + \tau_{yz}^2 + \tau_{xz}^2$$

Where
 τ : shear stress,
 I_1, J_2 : first stress invariant and second deviatoric stress invariant respectively,
 σ : compressive stress.

The material parameters included in the yield function equation might be calculated as a function of the soil strength parameters that can be obtained experimentally by the standard triaxial compression test common in civil engineering field. At different confining pressure levels several ultimate stress differences can be plotted in shear stress versus σ stress (Mohr circle) from which soil shear strength parameters (soil cohesion and soil internal friction angle) can be determined based upon Coulomb's failure criterion as follows:

$$\tau = c + \sigma_n \tan \phi$$

Where
c: soil cohesion,
 ϕ : soil internal friction angle,
 σ_n : normal stress.

It is worth noting that soil strength coefficients are plastic parameters, since a soil is plastically distorted at peak shear stress value.

Material and geometrical nonlinearity:

Two sources of nonlinearity arise when a soil is being under external load, material and geometrical nonlinearity. Material nonlinearity can be fully described by stress-strain relationship. Several functions that describe stress-strain behaviour of soils with different degree of accuracy were reviewed by Mouazen and Neményi, 1994. More than single stress-strain coefficient is required to fully represent the mechanical behaviour of any material under a general system of changing stresses (Duncan and Chang, 1970). These elastic coefficients are the modulus of elasticity and poisson's ratio that can be calculated by the following equations respectively based upon stress-strain curve of the standard triaxial test:

$$E = \frac{(\sigma_1 - \sigma_3)}{\varepsilon_1}$$

Where: E modulus of elasticity that can be calculated either at 0 or 50 % stress difference ($\sigma_1 - \sigma_3$). However calculating E at 50 % stress level is more suitable to get this stiffness parameter fig.1.

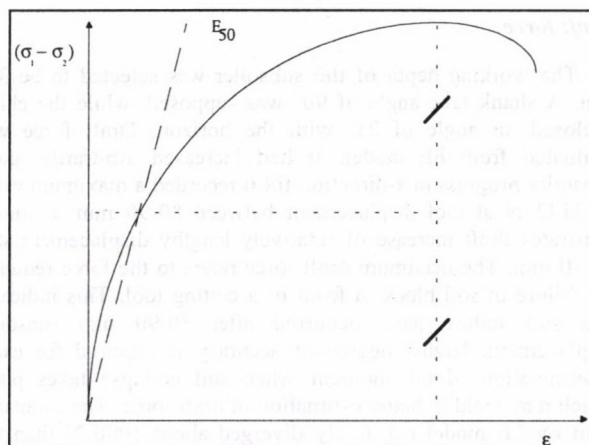

FIGURE 1

Shows modulus of elasticity at 50 % stress level

$$\nu = \frac{\Delta\varepsilon_1 - \Delta\varepsilon_v}{2\Delta\varepsilon_1}$$

Where
 ν : poisson's ratio,
 $\varepsilon_1, \varepsilon_v$: axial and volumetric strains respectively.

The forenamed elastic and plastic parameters used herein were reported by Araya and Gao (1995) as shown in table 1.

Table 1
Soil properties for non-linear finite element analysis
(Araya and Gao, 1995)

Property	Symbol	Value
Soil moisture	w	9.5 % d.b.
Cohesion	c	$9.13 \cdot 10^{-3}$ MPa
Wet bulk density	ρ	$1.43 \cdot 10^{-3}$ kg/cm ³
Compressibility	K	55.0 MPa
Modulus of elasticity	E	83.36 MPa
Poisson's ratio	ν	0.248
Angle of soil-interface friction	ϕ	23.8 deg
Angle of soil-metal friction	δ	15.0 deg
Tensile strength	T	$6.5 \cdot 10^{-4}$ MPa

In order to deal with material nonlinearity of soil, incremental analysis technique was used. Inside each step Newton-Raphson iteration method was adopted. While the geometrical nonlinearity was automatically solved by COSMOS program.

Finite element mesh:

Two dimensional, for nodes plane strain elements were selected to represent the soil as well as the rigid body of subsoiler fig. 2. The investigated subsoiler was described in details by Bánházi et. al. (1984). Interactions between the soil and subsoiler were considered so that an interface two nodes gap elements were inserted between the soil and cutting edges of the subsoiler. No stiffness was assigned to the gap elements. Instead, friction coefficients (tangent of external friction angle) were specified. Soil-tool adhesion, that may exist in some cases but not with sandy soil under dry conditions, was ignored. The selected boundary conditions were as follows, the bottom of the model was fixed in y-direction, while the rear and front sides were constrained in x-direction. All nodal points of the subsoiler were forced to move 10 cm in positive x-direction.

Results and discussions

Draft force

The working depth of the subsoiler was selected to be 340 mm. A shank rake angle of 90° was supposed, while the chisel enclosed an angle of 23° with the horizon. Draft force was evaluated from FE model. It had increased arbitrarily along subsoiler progress in x-direction till it recorded a maximum value of 3142 N at tool displacement between 80-90 mm. Figure 3 illustrates draft increase of relatively lengthy displacement step 20-30 mm. The maximum draft force refers to the force required for failure of soil block in front of a cutting tool. This indicates that soil failure have occurred after 80-90 mm subsoiler displacement. Higher degree of accuracy is required for exact determination of the moment when soil collapse takes place which may yield in better estimation of draft force. The estimated draft by FE model negatively diverged about 1000 N than the measured one by Araya and Gao (1995), table 2.

Table 2
Comparison between FE analysis and soil bin
(resources are denoted down the table)

Resources	Subsoiler thickness mm	Maximum vertical soil movement mm	Draft force F_x , N
1	20	65	5800
2	- shank 36 - chisel 60	121	3142
3	20	100	4200

- 1- FE predictions of Araya and Gao.
2- FE predictions of the authors.; 3- Soil test.

Draft increasing due to deeper cultivating depth 340 mm of FE model did not overcome the shortage of the estimating that would result when 2-d soil cutting model is adopted.

The highest negative horizontal stress concentrated at the tip of the subsoiler Figure 4. In addition, another negative horizontal stress area of high value, but not as much as that at the subsoiler tip, sat directly above the tip at the same horizontal strata where the chisel and the shank are linked as shown in fig. 4. The last area of high stress might be attributed to the incidence of the stresses exerted by both, the shank and the chisel with different rake angles. This demonstration of stress distribution within a soil body can only be achieved by the Finite Element method. The traditional analytical methods of soil cutting can not show stress distribution in the soil under cutting load.

Soil loosening

Soil loosening was estimated by soil volume change after 100 mm subsoiler displacement. Fig. 5 illustrates the final FE deformed form of the soil. It could be seen the maximum soil displacement in positive y-axis, as one indicator of soil loosening arose up to 121 mm. This number consists, to a far extent, with that was previously measured by Araya and Gao 1995, when they compared the results from FE analysis with the measured by soil test. Table 2 asserts that 121 mm soil displacement in positive y-direction predicted here agrees better with the measured one than that was predicted by Araya and Gao's FE model utilizing the same soil type and mechanical parameters. Thus by the developed FE model soil lifting by subsoilers can be well evaluated.

High shear stress value appeared at the subsoiler tip that tended to reduce upwards soil surface. Failure of agricultural soils has compressive, shear, and tensile forms. Therefore, further treatment of the results obtained from FE analysis should be performed later on to determine the dimensions of soil failure in shear and tensile only. In order to determine the shear failure at a given Gaussian point, the difference between maximum and minimum principal stress of this point should be compared with the maximum soil shear strength. When the principal stress difference exceeds the shear strength, soil failure must be considered at this point (Shen and Kushwaha, 1993).

Conclusions

1. The Construction of satisfactory FE model of soil cutting by medium subsoiler, whose cutting edge was relatively complex, was accomplished. The model was able to overcome the difficulty of assemblage the shank as well as the chisel together that possess different rake angles.
2. The draft force predicted from FE model was relatively in a good agreement with the measured one of previous study that was performed on a same sandy soil with a same mechanical properties. Further study must be done which should create 3-D FE model by which more accurate estimation of draft force would be resulted.
3. The maximum vertical soil movement predicted by FE model and soil bin test reported by previous paper showed a good agreement. Still to be done, however, is to determine the dimensions of soil rupture.

References

[1] ARAYA, K. - GAO, R.: 1995. A non-linear three-dimensional finite element analysis of subsoiler cutting with pressurized air injection. Journal of Agricultural Engineering Research, **61**, 115-128.
 [2] BÁNHÁZI, J. - JÓRI, J.I. - SOÓS, P.: 1984. Középmélylazító szerszámok összehasonlító vizsgálata. Budapest: published by Hungarian Academy of Science.
 [3] CHI, L. - KUSHWAHA, R.L.: 1991. A non-linear 3-d finite element analysis of soil failure with tillage tools. Journal of Terramechanics, Vol. 27, No. 4. pp. 343-366.
 [4] COSMOS/M Version 1.71 Finite Element Program. 1994. Advanced modules manual.
 [5] DUNCAN, J. - CHANG, C.Y.: 1970. Nonlinear analysis of stress and strain in soils Journal of the Soil Mechanics and Foundation Division. American Society of Civil Engineering, 96(sm5): 1629-1653.
 [5] GEE-COUGH, D. - WANG, J. - KANOK-NUKULCHAI, W.: 1994. Deformation and failure in wet clay soil: part 3, finite element analysis of cutting of wet clay by tines. Journal of Agricultural Engineering Research, **58**, 121-131.

[6] KUSHWAHA, R.L. - SHEN, J.: 1995. Finite element analysis of dynamic interaction between soil and tillage tool. Transaction of American Society of Agr. Engineering. Vol. 37(5): 1315-1319.

[7] LIU, Y. - HOU, Z.M.: 1985. Three dimensional nonlinear finite element analysis of soil cutting by narrow blades. Proceedings of International Conference on Soil Dynamics. Auburn, Alabama. June 17-19, Vol. 2 412-427.

[8] MCKYES, E.: 1985. Soil cutting and tillage. Amsterdam: Elsevier Science Publishers.

[9] MOUAZEN, A.M. - NEMÉNYI, M.: 1995. Modeling the interaction between the soil and simple tillage tool. MTA Agrár-műszaki Bizottságának Kutatási és Fejlesztési Tanácskozása. Gödöllő, Jan. 17-18, Vol. 2 15-27.

[10] NEMÉNYI, M. - MOUAZEN, A.M.: 1995. Agricultural engineering for the environmental protection. Proceeding of conference on environmental protection without borders. Győr. Szent Istvan út 5. October. 12. in print.

[11] PLAXIS Finite Element Code for Soil and Rock Plasticity 1994. Material models manual Version 0.5, Rotterdam: A. A. Balkema, Netherlands.

[12] SHEN, J. - KUSHWAHA, R.L.: 1993. Quick finite element analysis of soil tool interactions. Computer and Electronics in Agriculture, 9 (1993) 289-299.

[13] XIE, X. - ZHANG, M.: 1985. An approach to 3-d nonlinear FE simulative method for investigation of soil-tool dynamic system.. Proceedings of International Conference on Soil Dynamics. Auburn, Alabama. June 17-19, Vol 2 322-327.

[14] YONG, R.N. - HANNA, A.W.: 1977. Finite element analysis of plane soil cutting. Journal of Terramechanics, Vol. 14, No. 3, pp. 103-125.

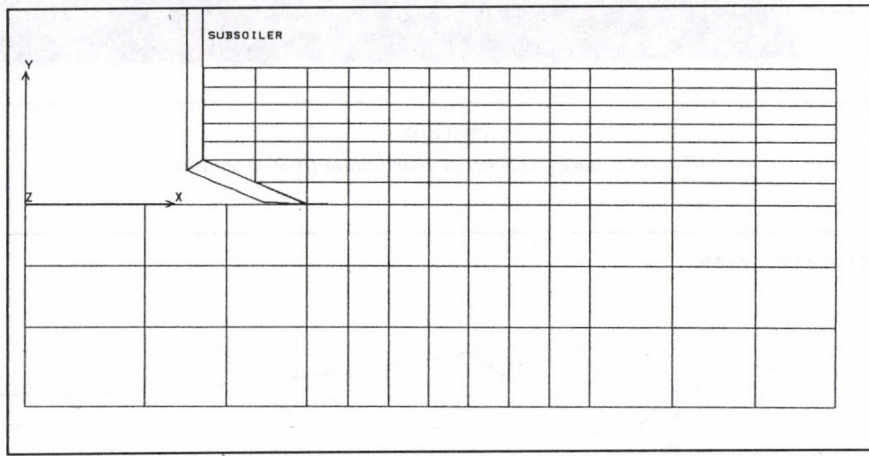

FIGURE 2
2-D finite element model of soil cutting by medium subsoiler

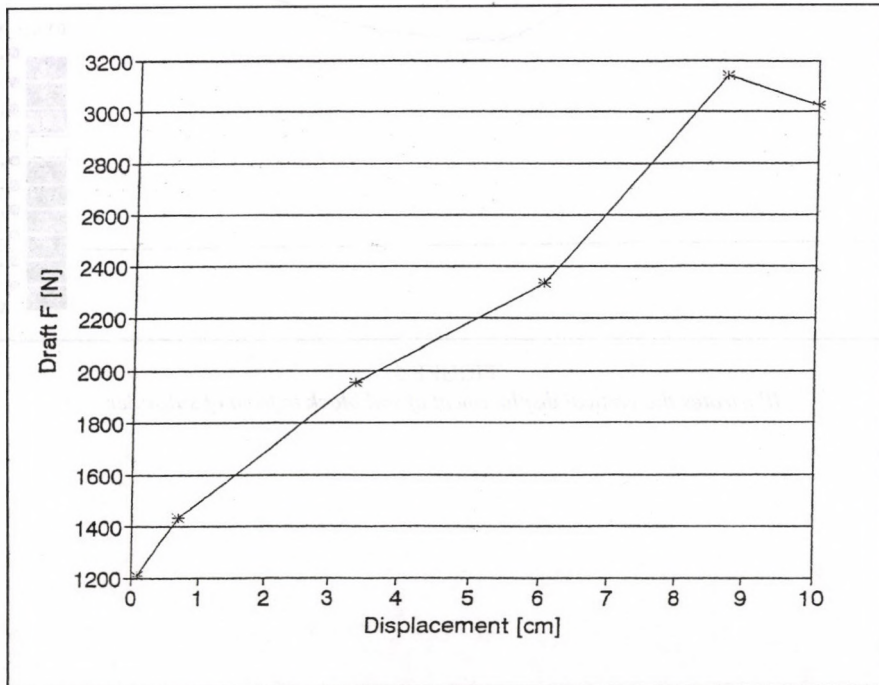

FIGURE 3
Draft force from FE model as a function of subsoiler displacement

EXAMINATION OF WORK ORGANISATION QUESTIONS OF THE SHEEP HUSBANDRY

L. LENGYEL - I. TÓTH

University of Agricultural Sciences, Gödöllő
College of Agricultural Engineering, Mezőtúr

In the last years the high rate decreasing in the stock has stopped and a moderate expansion is forecasted. The reasons are the improving market position of the meat and milk products and so the possibilities getting more income.

The debates about the utilisation directions can be considered as finished - due to the results of the scientific research. The overwhelming part of the professionals agree on the economical reasonableness of the specialisation. The market need promotes the meat, milk and the double utilisation directions. In the double utilisation both meat and milk can be the first utilisation aim.

The chosen technology and its frame, the **rational operation organisation** is an outstandingly important factor for the successful realisation of the utilisation direction.

The organisation of the work - according to the general (and accepted) terminology - is such an aimful, planned and continuous control activity which supports the efficient utilisation of the available sources and production factors (assets, workforce, biology resources) for the given tasks. The forming of the organisation is influenced by technology features, division of labour, the type of working phases and operations, the largeness of the branch, and so on.

The examination of the applied technology and the work organisation can produce much information to judge the efficiency and earning capacity of the production.

The aim of the examination, data base

In order to analyse the earning capacity and work organisation of the sheep production branch of the Gelej agricultural co-operative and especially milking, a continuous data collection has been carrying on for more years (1993-1995).

It is considered as important goals to recognise the influences of the society and economy changes, the proof for being large scale production, the expectable results and perspectives of species transformation.

The concrete plant data offers the chance to compare them to experimental results, too.

As it is judged the results of the breeding work for milk production aim species transformation of the co-operative which started some ten years ago, the integration of production and processing, the novel principles of the co-operation played significant role in the survival of the branch.

Specific earning, income from price

Recognising the advantages of the specialisation the co-operative crossed the Merino herd with Pleveni type. In order to improve milk production the Pleveni F₁ ewes were conceived by East Fries tups. On the basis of lactations of the species the milk production exposes a raising tendency (table 1).

The above data do not contain the milk quantity used for the growing up the lambkins.

The nurturing milk used by lambs till 90 days age was estimated to be 50-70 litre by **Schandl** (1966) or 70 litre by **L. Veres** (1966).

The average nurture period is between 60-70 days in the company under the investigation, so one can calculate 40-50 litre for each ewe. Thus the specific milk production is meant as the latter data added.

The income of the sheep branch on the three products is shown in table 2. Based on these one can see that 51.7-56.2 % of the income is resulted by meat production and 30.8-32.6 % by the milk, while the wool and the discarded ewes represents less than 10 %.

In the achievements the continuously developed technology and the work organisation played significant role.

The applied technology and work organisation

The managing of the company and the branch development was based on advised, rational decisions.

Practical housing solutions the technology apparatuses of the lamb growing and ewe keeping proved that the development activity was not influenced by the fashionable trends of the seventies and eighties. However, all of these means no conservative approach as it is proven by establishment of the milk house and cheese processing facilities as well as the introduction of a new interest system and the integration efforts.

A few technology and work organisation characteristics of the milking herd is demonstrated in the followings.

Placement of the ewe stock

The placement of the ewes is made according to the production aim in two sites within 3 kilometres to the milk house. The buildings are traditional with deep litter and covered fore-front.

The feeding of the ewes is made from fodder grid. The watering is inside the building with riffle. The foddering is outside the building from manger. The space in the barn is divided by grids. The climate of buildings is good, well ventilated.

Table 1
Trend of sheep milk sale

Species	1988	1989	1990	1991	1992	1993	1994	1995
Merino	42.68	46.73	43.22	41.62	45.06	39.97	50.71	50.09
Pleveni F ₁	64.67	62.40	61.30	56.06	49.70	65.45	71.61	87.00
Pleveni F ₁ selected	-	-	-	-	82.88	75.09	87.19	94.67
Pleveni F ₁ × East Fries	-	-	-	-	-	93.78	100.00	104.67
Pleveni F ₁ × East Fries selected	-	-	-	-	-	-	-	115.00

Table 2
The composition of the sheep breeding branch income

Description Exa. Years	Meat		Milk		Wool		Discard ewe		Compensation		Total	
	th.HUF	%	th.HUF	%	th.HUF	%	th.HUF	%	th.HUF	%	th.HUF	%
1993	10196	56.15	5587	30.78	1289	7.10	50	0.27	1036	5.70	18158	100
1994	14155	54.68	8018	30.98	1038	4.01	1269	4.90	1405	5.43	25885	100
1995	15389	51.72	9710	32.63	835	3.02	2106	7.07	1657	5.56	29756	100

Lambing

In order to keep the milk production level, the ewes are conceived naturally in the main season and the registered stock is inseminated artificially. The oestrus is finished at the end of November.

The lambs are sold at the age of 60 to 70 days as milky lamb. The flesh lamb sale is hardly made in the last years. The milking of the ewes starts in the last week of March or in the first week of April after the lamb separation.

The milking is carried out in an up-to-date stable equipment milk house which was built in 1982. The milking duration is between 120 and 150 days.

Organisation of milking work

In the company one shepherd cares 350-400 ewes. For the efficiency of the work, the simplification of work organisation and cost saving so called twin herds are formed. The meanwhile dried up as well as effete and milk producing ewes are sorted from the two herds. One shepherd has the duty to graze the milking ewes and drive them to the milking house. The other takes care after the non-milked ewes and the lamb feeding ewes at the beginning of milking period. His duty also to take care after the dried up ewes sorted out of the milked herd.

The ewes are driven for milking according to a previously set up order. So the milking is made continuous, especially in the case of a large number of sheep (2000-3000), resulting in high utilisation rate of milking equipment.

The feeding (grazing) of the milked herd is adjusted to the continuity of the milking. The number of milking operators is three plus one adjuvant persons for each pit. Their job is to let the ewes go in and out, to fix the ewes and serve fodder.

The ewes are milked twice daily. Depending on the number of milking ewes the work starts at 3 or 4 AM and 14 or 15 PM. The end of milking is determined by the number of ewes.

The work time is between 4 and 7 hours in each milking shift.

The treating of the milk is also a job of the milking personnel. On accreditation one person is responsible for the administration (filling up the bill of delivery, record of service, registration and indication of technical defects).

The greatest job of the branch is the milking the work process of which was investigated in a workday record, similarly to the previous years.

In short, not claiming completeness, The examination results are shown in the followings.

The milking ewe population is 2410 which is 10 % less than that in the last year. The average quantity of milk per one ewe is

0.5 litre. The highest yield (0.75 litre/ewe) is produced by the Pleveni F₁×East Fries bred.

The cycle period duration was 50 % higher than that in the previous two years. The reason may be found in the less skilled milking workers and the higher milk yield. It is proved again that the better utilisation of the time require the skillness and practice of the milking employees. That is demonstrated by the data of the milking operation record. One can recognise the longer time waste.

Despite all of these, the operation data of a 2×2×36 type milking apparatus expose 61.25 minute/ewe which is favourable compared to that of the 2×24 station equipment producing 111.3 minute/ewe.

The working efficiency examinations demonstrated that the milking time of the two double pit milking in two shifts is hardly different – in the case of less than 10 % population difference.

The specific milk production (0.5 l/ewe) of the year 1995 was 34 % higher than that of the previous years, but the working efficiency was more favourable only by 22-25 %.

Thus the higher specific yield may alter the attention from the work organisation problems and one can conclude falsely. Those all prove that the judgement of the work organisation efficiency gives a real picture only if complex, multiple factor evaluation is made.

References

- [1] BAK, J. - ZÁGONI, GY.: (1981) A 2x24 állásos Alfa-Laval juhfejő berendezés funkcionális vizsgálata. Report in Hungarian, Műszaki Intézet, Gödöllő 1-10 p.
- [2] FELLEG, J.: (1979) Mezőgazdasági munkaszervezés. Általános rész. Mezőgazdasági kiadó, Budapest
- [3] KOZDONET, J. al.: (1953) Labour Organisation during sheep machine milking. Animal Husbandry and Fodder.
- [4] LENGYEL, L.: (1993) Labour organization in the various types of sheep milking parlours Budapest, Állattenyésztés és Takarmányozás Supplement No. 1. p. 419-432.
- [5] LENGYEL, L. - KÖVÉR, L.: (1986) Juhágazat fejlesztése, a jóvelmezőség javítása. Magyar Mezőgazdaság 41. évf. 28. sz. 13 p.
- [6] LENGYEL, L. - TÓTH, I.: (1994) A gépi juhfejés technológiai-munkaszervezési tapasztalatai. Gödöllő Mezőgazdasági Technika 1-4 p.
- [7] SONCK, B.: (1993) Labour organisation in the milking small ruminant farms, Belgium, Animal Husbandry and Fodder Supplement
- [8] TÓTH, L. - BAK, J.: (1982): Az állami gazdasági fejőtermi fejőberendezéseinek műszaki felülvizsgálata, üzemeltetése. Report in Hungarian, Gödöllő

Year	1991	1992	1993	1994	1995	1996	1997	1998	1999
Population	2410	2410	2410	2410	2410	2410	2410	2410	2410
Milk yield (l/ewe)	0.5	0.5	0.5	0.5	0.5	0.5	0.5	0.5	0.5
Efficiency (%)	22	22	22	22	22	22	22	22	22

Table 2
The composition of the sheep breeding branch income

Year	1991	1992	1993	1994	1995	1996	1997	1998	1999
Total	100	100	100	100	100	100	100	100	100
Milk	30.78	30.78	30.78	30.78	30.78	30.78	30.78	30.78	30.78
Wool	1.10	1.10	1.10	1.10	1.10	1.10	1.10	1.10	1.10
Meat	32.87	32.87	32.87	32.87	32.87	32.87	32.87	32.87	32.87
Other	35.25	35.25	35.25	35.25	35.25	35.25	35.25	35.25	35.25

SIMULATION POSSIBILITIES OF CLIMATE CONDITIONS IN GREENHOUSES

M. SZABÓ - Dr. I. BARÓTFI
University of Agricultural Sciences, Gödöllő

Introduction

The artificial developed climate conditions have a determining role in the production in greenhouses. The most important functional parameters in greenhouses are the air temperature, soil temperature, radiation respectively the light intensity, vapour in the air and CO₂ concentration, but these are not independent of climate elements outside.

The heating and ventilation factors have a big role besides the outside and inside climate parameters in the regulation. However, it could be a problem how to maintain the more effective production by the rising of present energy-prices and costs. That is why it is important to examine what factors have a role in the reduction of the efficiency, and how they could be ceased.

The climate conditions in greenhouses develop as a result of complicated processes in a complex system. For this reason modelling of processes is reasonable and desirable to make the optimal climate parameters necessary for plants and in interest of decreasing the several experiments have to be made in connection with it.

The modelling possibilities today

The processes taking place in greenhouses have to fix an intensive growth of a living organism (plant) relatively delimited space from the environment, but as a system which is thermodynamically and in a considerable degree in connection with the environment and radiation. The characteristic of processes is, that the conditions – these are the essential factors for the vital conditions for plants – are determined by extremely many parameters connected with each other. Also characteristic of processes are that a lot of elements are determined by geographical data and climate environment. This makes simple the handling partly of processes and partly of mass of facts, from other side the physiological processes and demand of living organism in different phasis of growth are always changing, and with those mentioned above these are always in a close connection with different elements of environmental conditions that makes the process very complicated.

It is possible to solve these problems by using computers. The possibilities of optimisation of model parameters and modelling of processes are increased by computer media. There are more and more computer models for plant growth, for climate environment in greenhouses (Boot, Bergeijk, Jordan) known. By using PC-s and by presence of always more simulation languages and programs the modelling of these processes are significantly easier and faster, and using different softwares make these direct useful from the point of praxis view. But the practical usefulness is reflected considerably by that, how it can form a true notion about the reality. The easy handling and truth of reality" (exact reflection of real processes) are /strict requirement in connection with the applied simulation language.

The simulation language of modelling

There is the PCSMP (Personal Computer Continuous System Modeling Program) simulation language among others the most general/universal in the last time for the modelling of climate conditions of processes taking place in greenhouses. The PCSMP developed by IBM belongs to the group of simulation languages which are suitable for simulation of continuous systems, especially for description of dynamical non-linear processes –

like plant growth or change of climate conditions. The PCSMP is the most popular language with an easily handling in the biological researches. Using digital simulation languages – like PCSMP – the process descriptions is similar: for example, in PCSMP a function to integrate according to time (INTGRL) is available with other functions, these can be built in mathematical functions by programming. The biggest advantage of PCSMP programming is that the original equation need not be set into the form the computer can understand as it always required in other common languages.

The structure of program

Fig. 1 shows the scheme for PCSMP program with a numerical integration. All PCSMP programs are divided into three functional sections:

- INITIAL, that define the initial conditions, input parameters and constants,
- DYNAMIC, dynamical part, this is the essential part of program, this contains the mathematical functions describing processes,
- TERMINAL, this part is for setting and visualisation of outgoing data.

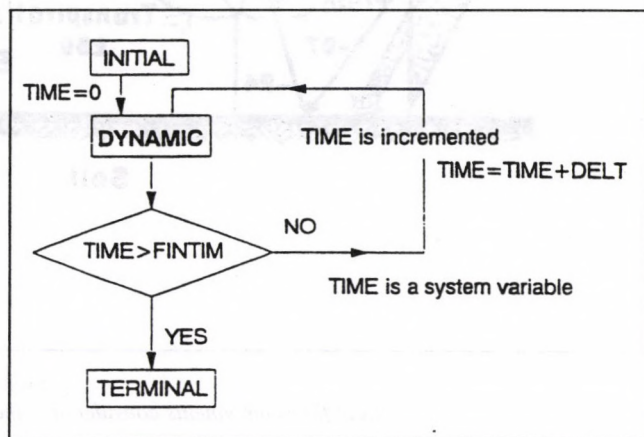

FIGURE 1

Structure of PCSMP with respect to time change

The simulation model

Takakura (1992, Japan) has developed a complex model for the forming the physical and biological complicated processes taking place in greenhouses using the simulation language PCSMP. The important point in the description of systems is that the basic concept of the model is a flow of energy. A greenhouse is a system closed, but in connection with the environmental conditions, that is why the net incoming energy is equal to net outgoing energy. Fig. 2 shows the energetic (heat) flow components in greenhouses.

The model makes possible modelling the processes (climate and plant growth) taking place in greenhouses with different covering materials and with different size applied different production technology. The structural construction of model is formed by the processes taking place on each other in the nature. The program searches the processes in greenhouses separately one after the other, then it is building the model for more and more complex and complicated processes being built upon each other. This kind of model can be called a distributed model, while the objects can be grouped in separate regions. The model build up to each other but they can be solved also independent and connected with other parameters, too. For example, however, if there is a large temperature gradient in one object, more than two

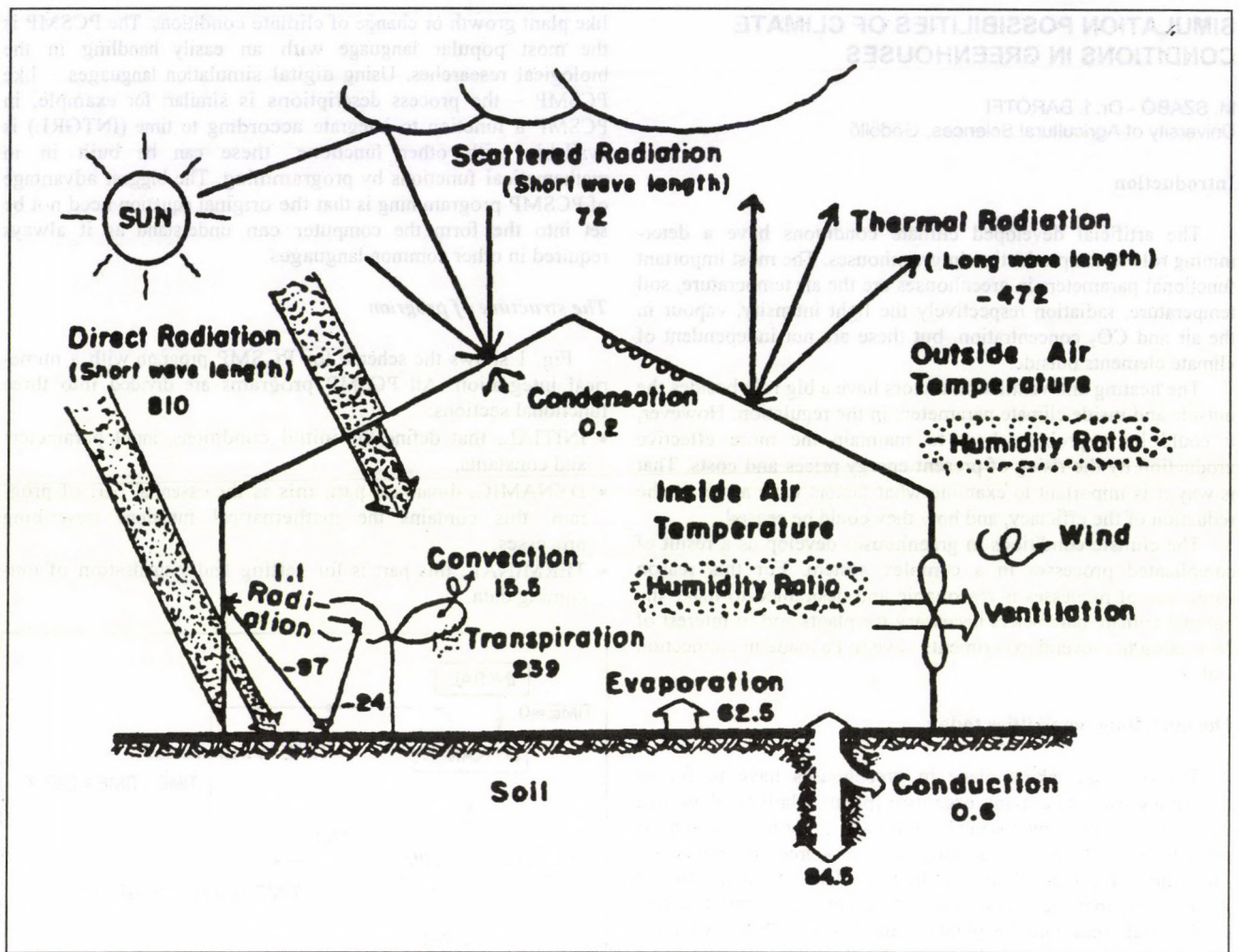

FIGURE 2
Heat flow components considered in the dynamic model developed by Takakura

variables are assigned to one object such as the soil layer even if the model is one-dimensional. The soil is divided into several layers, and in each soil layer temperatures are defined separately.

The model consists of 8 subprograms and submodels based on each other, these are in order as follows:

1. Soil temperature in soil layer (air temperature, solar radiation, latent heat, heat transfer are involved)
2. Solar radiation environment (definition of the orientation of sun and radiation transmissivity of covering material)
3. Air temperature under cover with different material and size (under mulch with different colours, under plastic cover, in plastic tunnel, in greenhouse with glass)
4. CO₂ environment (concentration in soil layer, and in a plastic house)
5. Water and water vapour environment
6. Control function (Temperature control logic, feedback and feedforward control)
7. Plant response to the environment (plant photosynthesis and respiration, stomatal resistance in relation to external CO₂ concentration)
8. Plant growth model (yield model and dry matter production)
9. The part tested the climate in greenhouse starts from the modelling of temperature and energy flow in soil layers, until the air temperature, radiation conditions by the solar-geometrical and geographical parameters. On the basis of the modelling the climate conditions in greenhouses it is possible to research the plant growth. Our research is aimed firstly at

climate conditions in greenhouses, and within the models for air-temperature and radiation inside the glasshouse.

Variables of models

The input data, parameters and constants figuring in the models are classes among several groups with their character and initial conditions. One of the groups is the physical parameters for greenhouse, these contains the data about the covering materials and the size of greenhouse, for example the height of greenhouse and the thickness of covering material. There are in the other group the geographical data, these give the orientation and placing of greenhouse, and the solar geometrical data, such as the direction of solar radiation, the intensity of solar radiation on earth surface. There are in this group also the climate and weather data, for example the extinction coefficient of the atmosphere.

Other main group is the physical characteristic in connection with heat flow, of structural and productional materials in the production in greenhouses, such as the different heat transfers, heat capacity, thermal conductivity data, emissivity and absorption coefficients, etc.

In the group of the input data are the parameters for the climate conditions outside the greenhouses (for example the outside daily average air-temperature), the initial climate conditions inside the greenhouse (such as the initial temperature values for soil layers, air layers, vapour in the soil, in the air).

Output data are the actual value of climate parameters inside the greenhouse which influence the living conditions and growing of plant in given time interval. These values are initial for those models, which are describing the plant growth models, where the output data is the dry matter production of plant.

Simulation model for determining the climate-parameters in glasshouse

In the form of a complicated model, processes of which are built on each other, the truth of reality and the accuracy of submodels are very important, first of all in the models for climate conditions. The climate conditions in the greenhouse are influenced by the outside climate environment. The climate conditions change not only by seasons, but also by day (for example the radiation intensity changes with clouding, the temperature and humidity of air with the wind), so that the simulation model determining the climate parameters in a glasshouse start off the model describing the change of outside climate parameters.

The parameters and initial conditions in the model available for modelling of temperature in a glasshouse with simple cover and with pad and fan ventilation system are:

1. Physical parameters of greenhouse/glasshouse:

size of greenhouse: average height of a greenhouse,

parameters of covering material: thickness, index of refraction, extinction coefficient, absorptivity of the cover for different solar radiation component,

parameters for soil: Emissivity of the floor, thermal conductivity of the floor [kJ/hr/m²/°C], thickness of soil layers [m], Soil thermal conductivity [kJ/m³/°C], Greenhouse soil index (dryness factor of the soil surface), Stephan-Boltzmann constant, convective heat transfer and heat capacity of soil and of air [W/m²/°C],

parameters for ventilation: effective emissivity of air [m³/m²/hr], efficiency of pad and fan,

parameters of radiation and heat-transfer: absorptivity of the covering material for diffuse radiation, absorptivity of the floor for the solar radiation, reflectivity of covering material for longwave radiation, reflectivity of covering material for diffuse radiation, emissivity of covering material, emissivity of the floor, latent heat for evaporation [kJ/kg], Lewis number.

2. Geographical and meteorological data:

solar constant (1360 W/m²) v. [kJ/m²/hr], a extinction coefficient of the atmosphere (dim. nélkül=0.7), latitude of the place, number of day,

3. Characteristic for factors determining the climate conditions:

outside daily average air temperature, daily amplitude of air temperature, temperature of soil layers, dew-point temperature of outside air, density of air, humidity ratio in greenhouse [kg/kg], dry-bulb temperature after pad.

There are the initial conditions in this three groups. In dynamic part of the program there are defined the fourth group of input parameters, these are:

4. Initial values for climate parameters (in the zero time-point):

initial temperature of cover [°C], initial temperature of inside air layers, initial humidity ratio of inside air layers, initial temperature of soil surface, initial temperature of soil layers.

5. Variable for timing of simulation:

start-time of simulation, final time of simulation, time steps for printing of output data and time interval. That means the program saves the output data by the given time intervals.

The unit of measures correspond to the SI system.

Summarized the input parameters are in the model:

Geographical orientation: Geographical latitude, longitude

Time: number of day (Julianus day)

Climate: extinction coefficient of atmosphere

Other outside climate-elements: outside air-temperature, dew-point temperature of air

Output data depending of time:

– temperature of inside air layers,

– temperature of soil layers,

– air humidity,

– radiation conditions in greenhouses.

Summary (Conclusions)

The tested model describes the processes taking place in greenhouses most completely. This model is suitable for the simulation of climate conditions of mulch and greenhouses with different structure and type (mulch, row cover, plastic tunnel, simple and double covered greenhouses, glasshouse) with different type of covering materials (glass and plastic film). The processes can be defined in the course of simulation at any time, at any time interval, at any climate conditions, and at any geographical place.

There are a lot of elements and details elaborated -not yet too exactly- in relation to vital processes by plants, to thermal and light conditions, to the connection between outside environment, radiation, and the greenhouse. For example, it can be a problem to use the correct value for giving the average temperature and the amplitude for temperature outside (initial values). This model is destined to estimate the daily development of climate elements at any time in a year, at any day as exactly as possible.

It can be determined by our and others' research in this field, that the condition of covering material is not negligible in the radiation and light conditions in greenhouses. This factor is left out of consideration by the known models. That is why the models have to be formed more correct in the determination of the connection between the covering material conditions (ageing and condensation) and the inside climate ones. Now the researches and experiments are directed to find out the adaptation of the worked out programs, and they show in the direction of the exact revelation of connection between the light- and radiation transmissivity and condition of covering materials.

References

- [1] BARÓTFI, I.: 1993. Energiafelhasználói kézikönyv, Budapest
- [2] BEKE, J. - VAS, A.: 1993. Hőtechnika a mezőgazdasági gépészetben, Gödöllő
- [3] BERGEIJK, J.: 1993. Energetic Flows Model in Greenhouses, Gödöllő
- [4] BOT, G.P.A.: 1983. Greenhouse climate: from physical process to dynamic model. Ph.D. dissertation, Wageningen Agricultural University
- [5] PENNING DE VRIES, J.W.T. - VAN LAAR, H.H.: 1982. Simulation of growth processes and model BACROS, in Simulation of Plant Growth and Crop Production, Pudoc, Wageningen, The Netherlands, chap. 3.3.
- [6] SZABÓ, M.: 1996. Energetic Aspects of Condensation in Greenhouses. World Renewable Energy Congress IV. Denver, USA.
- [7] TAKAKURA, T. - JORDAN, K.A. - BOYD, L.C.: 1971. Dynamic simulation of plant growth and environment in the greenhouse. Trans ASAE, 14(5):964-971.
- [8] TAKAKURA, T.: 1983. Climate under Cover. Digital Simulation in Plant Bio-Engineering.

MEASURING ODOUR EMISSION OF POULTRY HOUSES, THE EXPERIENCES OF THE MEASUREMENTS

A. BÉRES - Dr. A. MITYÓK
University of Agricultural Sciences, Gödöllő
College of Agricultural Engineering, Mezőtúr

Introduction

The professionals began to deal with the environment pollution odour effect of the animal husbandry at the beginning of the 1960 years. In the animal houses and barns as well as in the animal farms the increase of the animal stock caused an increase in the liquid and litter manure quantity and the amount of smelly materials, too. Almost everybody has his/her own experience with smell emission of the large scale plants. The inhabitants of the nearby villages know especially well the features of the animal farms located too close to the habited areas without considering the typical wind direction and the features of the ground.

In the first examinations of the odour getting into the environment the smelly materials emitted by the manure were determined. It was found that they are mainly organic materials, e.g. hydrocarbons, alcohols, esters (White et. al. 1971), carbonacids (Miner 1975), sulphur containing and other compounds. Simultaneously to the instrumented concentration measurement the individual materials were examined by sense perception determining their limen smell (the smelling limit) what an „average nose” person already senses. During the investigations the researchers stated that the extent of the smell can not be characterised by the concentration of the individual components. Actually in the determination of the smelly components some 150 different odorous compounds were sorted out (Spoelstra, 1980). Their complex mixture as the odorous material results the smell emitted by the animal houses and litters, but the interrelationships of the mixtures are not known. In the table 1 some odour materials, the characteristic of their odour and their limen smell is included.

Table 1

A few odour material types, their character and smelling limit of theirs (Bouscaren 1980; Miner 1975)

Compound	Smelling limit (ppm)	Odour character
Allylic-mercaptan	0.005	Garlic-like
Ammonia	45	Pungent
Benzil-mercaptan	0.003	Putrid
Crotyl-mercaptan	0.002	Vermin stinking
Hydrogen sulphide	0.1	Rotten egg
Metil sulphide	0.002	Rotten vegetable
Piridin	5	Irritating
Skatole	3	Faeces
Tiofenol	0.005	Disgusting

Also in the individual examinations discovered the effects of the smell emitted by animal houses to the people living nearby. Such effects are the reduction of aliment and liquid consumption, difficulty in breathing, sleeping troubles, headache, allergic reactions, fainting, sickness, vomiting (Matzke 1986).

In the examinations on the odour materials and their effects more trial has been made to judge the magnitude of the smelling effect. The recent accepted method of measuring the magnitude of the smelling effect is the dynamic olfactometry.

The characteristic odour emission of the different animal types and husbandry technologies are shown in fig. 1.

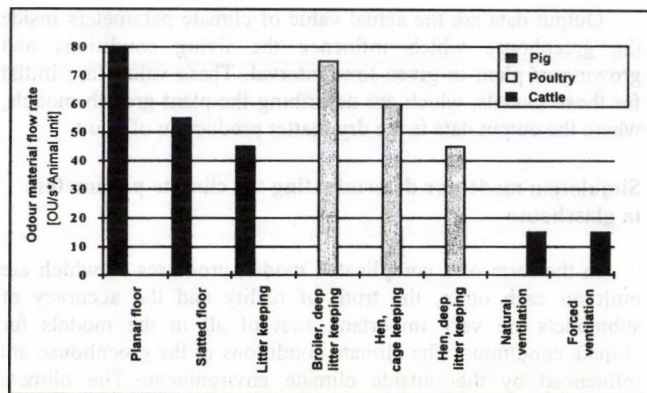

FIGURE 1

Smell emission of pig, poultry and cattle houses in different production technologies (Oldenburg, Mannebeck 1987)

The aim of the investigations to find the relationship between the smell emission and the applied husbandry technology.

Methods

The measurements were planned taking into account the Hungarian Standard regulations of the dynamic olfactometry (MSZ 13-108-85). The Hungarian measurement regulation is based on the measurement experience and the VDI guidelines (VDI 3881, 3886). The essence of the measuring method is that the smelly and also flowing gas is mixed with a flowing indifferent reference gas (which may be clear air or oxygen gas) until the measuring person senses the presence of the smell through a nose mask formed for detecting. The dilution ratio of the smelly gas is decreasing during the measurement, the gas sample to be evaluated by the measuring person has a gradually rising smell concentration. So the adverse adaptation effect on the measurement may be avoided. When the measurer person detects the presence of the odour, the volume flow rates of the reference and the odorous gases can be read and the limit dilution value or the odour number can be determined as follows.

$$Z = (V_m + V_h) / V_m$$

Where

V_m = the volume flow rate of the sample gas

V_h = the volume flow rate of the diluting gas

The Z value is referenced to the odour material content of unit volume so expressed the odour concentration in odour unit/m³ (OU/m³). One OU/m³ is the amount of the odour material what already generates smell sensing in 1 m³ neutral air.

In the measurements the selection and the number of the measurer persons is very important. One measuring group should contain at least eight persons. The selection of the persons should be made in accordance of the MSZ 7304/10 regulation. The accomplishment of the measurement in time, and the evaluation of the results is described in the standard regulation in detail.

The air velocity values were determined with rotary air speed meter for the air flow rate values.

The circumstances and results of the measurements

The measurements were accomplished in broiler chicken houses. The investigations were made in two stalls. In both houses the same feeding apparatuses (drag type feeder) and watering schemes (suspended, angle valve with ball float circular watering devices) were in usage. The litter method, the ventilation system, the age and density (12 chicken/m²) of the

stock and the fodder were the same in both stalls. In one house room heating, in the other gas upto four week age of the stock infrared radiation heating were used.

The measuring results are shown in fig. 2 and 3.

Conclusions

- One can recognise on the basis of the fig. 2 that there exist a significant relationship between the age of the broiler chicken age and the odour emission.
- The fig. 3 shows that the odour emission is influenced by the heating method in the stall. In the case of the infrared heating the odour emission increases in smaller rate when the infralamps are used.
- Compared to the room heating the odour emission is lower at the end of the cramming period when infralamps are used.

References

[1] BOUSCAREN, R.: Les odeurs et la desodorisation. Techniques et Sciences, Municipales, 79. k. 6. sz. 1984. p.313-341
 [2] KOVÁCS, F.: Állathigiénia, Mezőgazdasági Kiadó, Budapest, 1980.

[3] MATZKE, U.: Geruchsbelastigung und ihre immissionschutzrechtliche Beurteilung in Nordheim-Westfalen. VDI Berichte, 561.sz. 1986. p.387-398
 [4] MINER, J.R.: Management of odours associated with live-stock production. In: Managing Livestock Wastes, PROC-275, 1975. St. Joseph
 [5] OLDENBURG, J. - MANNEBECK, H.: Emissionsminderung bei Stallungen - Stand der Technik. Landtechnik 42. sz. 1987. p.476-478
 [6] SPOELSTRA, S. F.: Origin of objectionable odours components in piggery wastes. Agricult. Environm. 5. sz. 1980. p.241.
 [7] WHITE, R.K. et al: Chromatographic identification of malodors from diary animal waste. In: Livestock Waste Management, 1971. A.S.A.E., St. Joseph
 MSZ-13-108-85 „Kellemetlen szagok küszöbhígítási értékeinek meghatározása dinamikus olfaktométerrel” (Determination of the limit dilution value malodours by means of dynamic olfactometer)
 MSZ 7304/10-82 „A szaglóképesség vizsgálata” (Determining smelling ability)
 VDI 3881 „Olfaktometrie-Geruchswellenbestimmung, Grundlagen” VDI-Verlag GmbH, Düsseldorf, 1986. p.1-28.

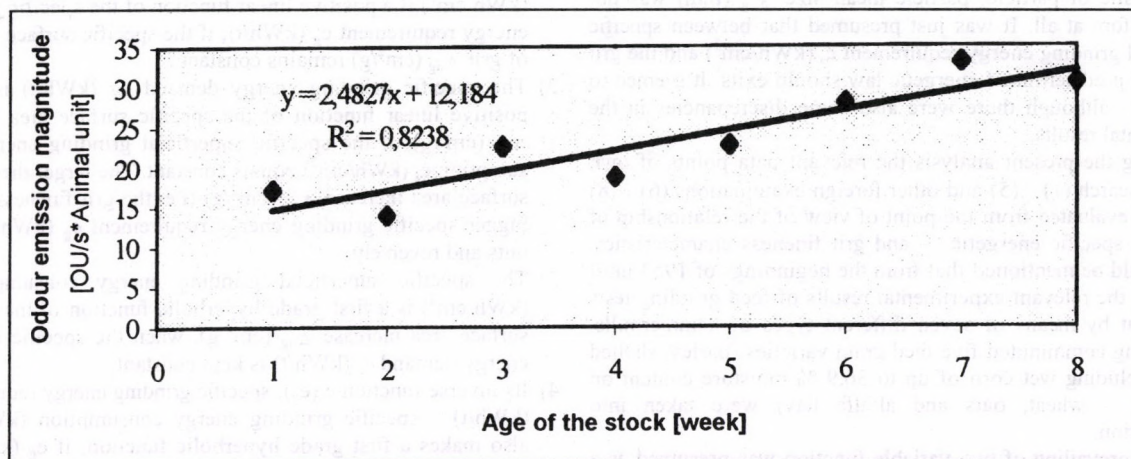

FIGURE 2
 Smell emission magnitude versus the age of broiler chicken stock (Room heating was used)

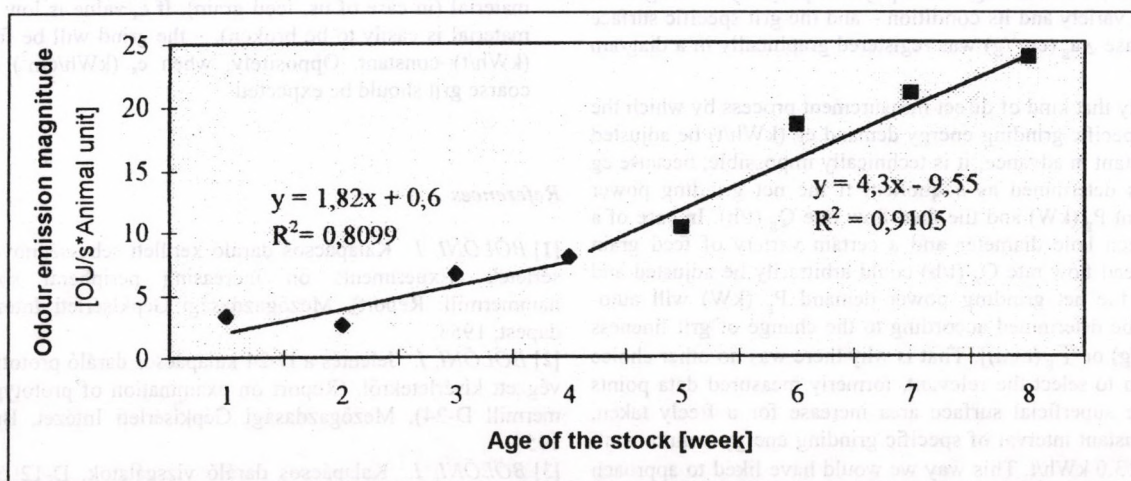

FIGURE 3
 Smell emission magnitude versus the age of broiler chicken stock (Infrared heating was used for four weeks)

ANALYSIS OF GRINDING'S BASIC ENERGETIC RELATIONSHIP (OTKA T 016124)

Dr. I. BÖLÖNI
Hungarian Institute of Agricultural Engineering, Gödöllő

This year aim of this analysis was a preliminary estimation of the two-variable relationship of

- (1) specific grinding energy requirement: e_g (kWh/t)
- (2) specific superficial grinding energy consumption: e_s (kWh/cm²) and the
- (3) grit fineness characterised by the
 - specific surface area increase: Δa_g (cm²/g) or
 - the linear particle mean size: \bar{x}_g (mm)

on the bases of earlier own and some foreign investigations (1)...(8) in order to prepare a recently started research project of OTKA (National Fund of Scientific Research, Hung.).

Namely in former OTKA examination (T 5392) many interesting new regularities were discovered in the hammermill's science of operation and our attention was directly called to the extraordinary importance of the correlation of the specific superficial grinding energy demand e_s (kWh/cm²) and the grit fineness, first of all to the grinds' specific surface area increase Δa_g (cm²/g). The relation of those ones – including the second characteristic of particle, particle mean size \bar{x}_g (mm) was not known before at all. It was just presumed that between specific superficial grinding energy requirement e_s (kWh/cm²) and the grit fineness a predetermined energetic law should exist. It seemed to be logic, – although there were also some discrepancies in the experimental results.

During the present analysis the relevant data points of own former research (1)...(5) and other foreign examinations (6)...(8) were first evaluated from the point of view of the relationship of the above specific energetic – and grit fineness characteristics. Here should be mentioned that from the beginnings of 1953 until nowadays the relevant experimental results of feed grinding tests carried out by means of seven different types of hammermills, after having comminuted five feed grain varieties (barley, shelled corn – including wet corn of up to 36.9 % moisture content on wet base, – wheat, oats and alfalfa hay) were taken into consideration.

Since prevailing of two-variable function was presumed as a method of analysis was chosen the specific grinding energy consumption e_g (kWh/t) to be kept constant and the correlation of the other two variables – specific superficial energy requirement e_s (kWh/cm²) – which might be a physical property of the ground feed grain variety and its condition – and the grit specific surface area increase Δa_g (cm²/g) was registered graphically in a diagram (fig. 1)

Namely that kind of direct measurement process by which the value of specific grinding energy demand e_g (kWh/t) be adjusted to be constant in advance, it is technically impossible, because e_g (kWh/t) is determined as a quotient if the net grinding power requirement P_g (kW) and the feed flow rate Q_g (t/h). In case of a given screen hole diameter and a certain variety of feed grain only the feed flow rate Q_g (t/h) could arbitrarily be adjusted and after that the net grinding power demand P_g (kW) will automatically be determined according to the change of grit fineness [Δa_g (cm²/g) or \bar{x}_g (mm)]. That is why there was no other choice for us than to select the relevant, formerly measured data points of specific superficial surface area increase for a freely taken, almost constant interval of specific grinding energy requirement: $e_g \approx 7.5 \dots 13.0$ kWh/t. This way we would have liked to approach the national mean value of specific grinding energy demand $e_g \approx 10$ kWh/t which is characteristic for the Hungarian feed mills now. According to the regression analysis a relationship to a first grade hyperbole was achieved (fig. 1) by quite high correlation coefficient $R = 0.9567$.

Further on the relationship of the specific superficial grinding energy requirement e_s (kWh/cm²) and the specific grinding energy consumption e_g (kWh/t) (fig. 2) was evaluated having kept the specific surface area increase $\Delta a_g = 40 \dots 60$ cm²/g \cong constant that makes about $\bar{x}_g = 1.0 \dots 1.5$ mm linear particle mean size. The function $e_s(e_g)$ proved to be a positive linear relation by close approximation of a correlation coefficient $R = 0.90$.

From the two graphs and a simple logic conclusion can be stated that the two-variable function searched for, it is probably

$$e_g \text{ (kWh/t)} = 10^6 \cdot (g/t) \cdot e_s (10^{-7} \cdot \text{kWh/cm}^2) \cdot \Delta a_g \text{ (cm}^2/\text{g)} \dots (1)$$

were the symbols' interpretation is the same which was mentioned before.

As far as Equ. (1) concerns, it seems to be a hyperbolic paraboloid that is the product of two independent variables which equals the third dependent variable. Having kept constant of each variable the relationship of the two other ones can be investigated as a one-variable function in plane. Formulae can be derived from Equ. (1).

Abstracts

- 1) The specific superficial grinding energy consumption e_s (kWh/cm²) is a positive linear function of the specific grinding energy requirement e_g (kWh/t), if the specific surface increase of grit Δa_g (cm²/g) remains constant.
- 2) The specific grinding energy demand e_g (kWh/t) is also a positive linear function of the specific surface area increase Δa_g (cm²/g), if the specific superficial grinding energy consumption e_s (kWh/cm²) equals constant. The larger the specific surface area increase Δa_g (cm²/g) (i.e. the grit fineness) is, the bigger specific grinding energy requirement e_g (kWh/t) amounts and reversely.
- 3) The specific superficial grinding energy consumption e_s (kWh/cm²) is a first grade hyperbolic function of the specific surface area increase Δa_g (cm²/g), when the specific grinding energy demand e_g (kWh/t) is kept constant.
- 4) Its inverse function $e_s(e_g)$: specific grinding energy requirement (kWh/t) – specific grinding energy consumption (kWh/cm²) also makes a first grade hyperbolic function, if e_g (kWh/t) = constant.
- 5) From the two specific energy demands e_s (kWh/cm²) the specific superficial energy consumption seems to be an independent variable, – as a physical property of the ground material (in case of us, feed grain). If e_s value is low (i.e. the material is easily to be broken), – the grind will be fine, if e_g (kWh/t) = constant. Oppositely, when e_s (kWh/cm²) is high, coarse grit should be expected.

References

- [1] BÖLÖNI, I.: Kalapácsos daráló kerületi sebességnövelési kísérletek (Experiments on increasing peripheral speed of hammermill: Report), Mezőgazdasági Gépkísérleti Intézet, Budapest, 1953.
- [2] BÖLÖNI, I.: Jelentés a D-24 kalapácsos daráló prototípusával végzett kísérletekről. (Report on examination of prototype hammermill D-24), Mezőgazdasági Gépkísérleti Intézet, Budapest, 1954.
- [3] BÖLÖNI, I.: Kalapácsos daráló vizsgálatok: D-12 és D-24. (Hammermill investigations of D-12 and D-24) Mezőgazdasági Gépkísérleti Intézet, Budapest, 1957.
- [4] BÖLÖNI, I.: Kalapácsos daráló vizsgálatok különös tekintettel a daráló üzemiállapotát meghatározó jellemzők egymás közötti összefüggéseire. (Hammermill research with special concern on

the interdependencies of characteristics which determine the operational condition of the mill: Ph.D. Theses), Mezőgazdasági Gépkísérleti Intézet, Budapest, 1960, 1-114 pp.

[5] A kalapácsos daráló aprítási mechanizmusa és gépüzemeltetési összefüggései. (Hammermill's grinding mechanism and relationships of its science of operation: Dr.Sc. Theses) Mezőgazdasági Gépkísérleti Intézet, Gödöllő, 1972, 1-180 p.

[6] VÉHA, A.: Mezőgazdasági terményaprítás kalapácsos darálóval (Comminution of agricultural grains by means of hammer-

mill: Ph.D. Theses), University of Horticulture and Food, College of food Industries, Szeged, 1994, 1-115 pp.

[7] CSERMELY, J.: A nedves szemeskukorica zúzálektárolás műszaki és technológiai összefüggései. (Technical and technological relationships of ground wet corn's storage: Dr. Sc. Theses), MÉM Műszaki Intézet, Gödöllő, 1988, 1-182 p.

[8] STEVENS, C.-WESTHUSIN, V.V.: The effect of Peripheral speed in hammermill grinding, Kansas State University, Manhattan, KS, 1983. Aug., K-1...25 p.

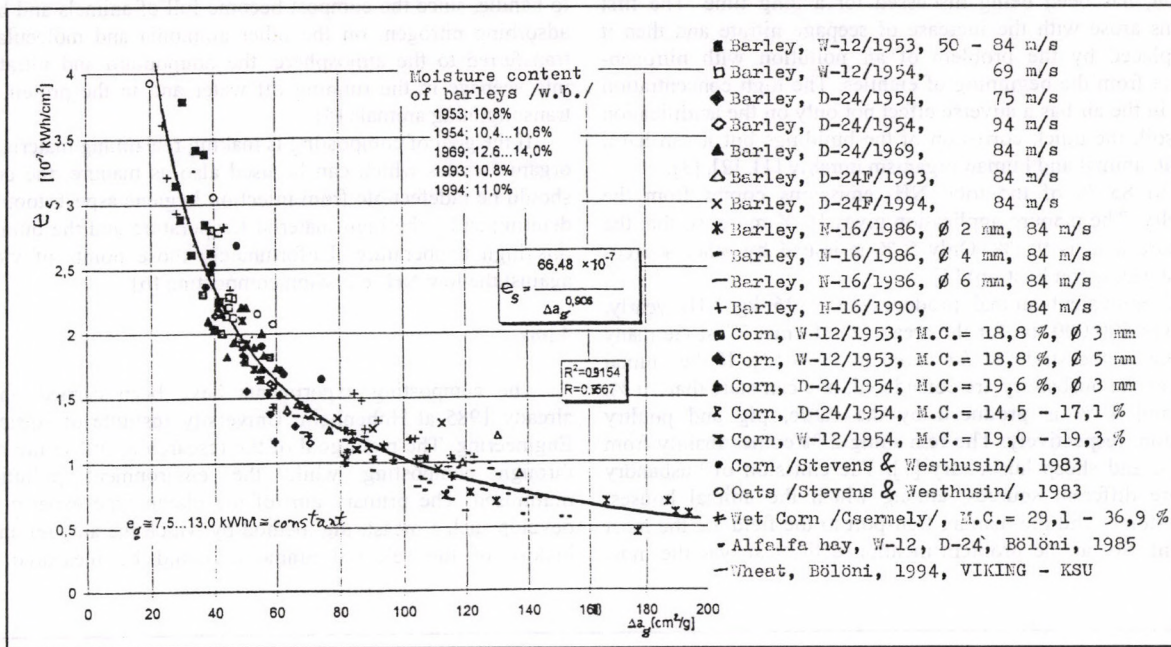

FIGURE 1

Experimental relationship of the specific superficial grinding energy consumption e_s (kWh/cm²) and the specific surface area increase Δa_g (cm²/g, if the specific grinding energy requirement $e_g \cong 7,5 \dots 13,0$ kWh/t \cong constant.

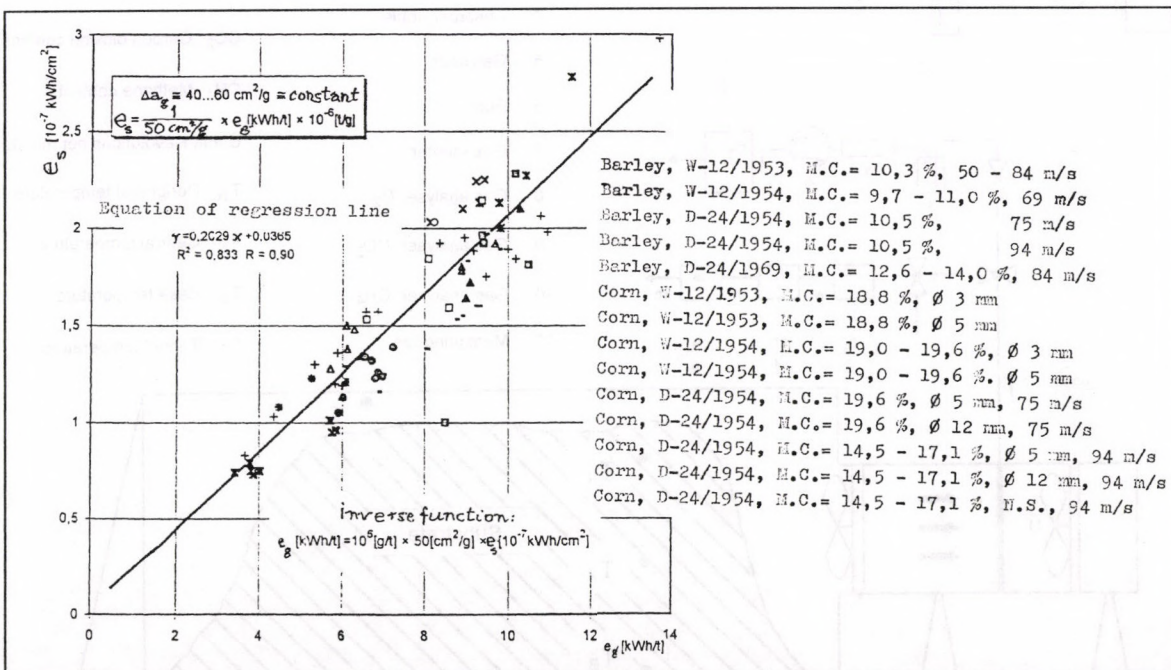

FIGURE 2

Experimental correlation of the specific superficial grinding energy consumption e_g (kWh/t), if the grit specific surface area increase $\Delta a_g = 40 \dots 60$ cm²/g \cong constant.

AMMONIA EMISSIONS FROM COMPOSTING ANIMAL WASTES IN WINDROWS

K. CSEHI - J. BECK - T. JUNGBLUTH
 University of Hohenheim,
 Institute of Agricultural Engineering

Introduction

The nitrogen, as one of the greatest source of environment pollution, has been being discussed for a long time. The first problems arose with the increase of seepage nitrate and then it was replaced by the problem of air pollution with nitrogen-ammonia from the beginning of eighties. The high concentration of NH_3 in the air has a adverse effect not only on the acidification of the soil, the quick corrosion of the buildings but it can harm the plant, animal and human organism durably [1], [2], [3].

80 to 85 % of the total NH_3 emissions comes from the husbandry. The manure application gives 10 % more, so that the agriculture load is 95 %. Only 5 % is issued by other sources (exhaust gases, combustion) [4].

One equivalent animal produces some 36 kg NH_3 yearly, which was 500 000 ton for the area of the former West-Germany according to the study of *Isermann* in 1990 [3]. If the animal species of the husbandry are considered, one can state that 70 %, 24 % and 4 % is produced by the cattle, pig and poultry production, respectively. The remaining 2 % comes mainly from the horse and sheep husbandry [7]. The emission of husbandry has more different sources, among which the animal houses, manure storers and the manure transport to the field are the most important. So far the problem mentioned the last was the most

outstanding in the research. However, the need for estimation the N losses in the agriculture is increasing recently. This is where the ammonia emission time profile and amount of manure composting is connected. According to the investigations of *Schuchardt* the nitrogen loss of the composting is between 3 and 75 % [6]. The wide range is explained by the differences in factors affecting compost making (e.g. dry solids content, C/N ration).

As for nitrogen content the clamp composting should be considered as an open system. This is why the problem is difficult to handle, since the compost become full of animals and bacteria adsorbing nitrogen, on the other ammonia and molecular N is transferred to the atmosphere, the ammonium and nitrate goes into seepage in the running off water and in the protein of the transmigrating animals [5].

If the goal of composting is making reclaiming materials from organic wastes which can be used also as manure, the compost should be indefectible from infection hygiene aspect, too. This is determined by the high material temperature and the duration of this high temperature. Unfortunately those points of view are against the low NH_3 emission composting [6].

Aims

The composting experiments have been carried on since already 1985 at Hohenheim University Institute of Agricultural Engineering. The main goal of the research to utilise the manure through composting while the environment pollution is minimised. The primary aim of the clamp type experiments to develop such a measuring method by which the amount and time history of the released ammonia could be measured. As a

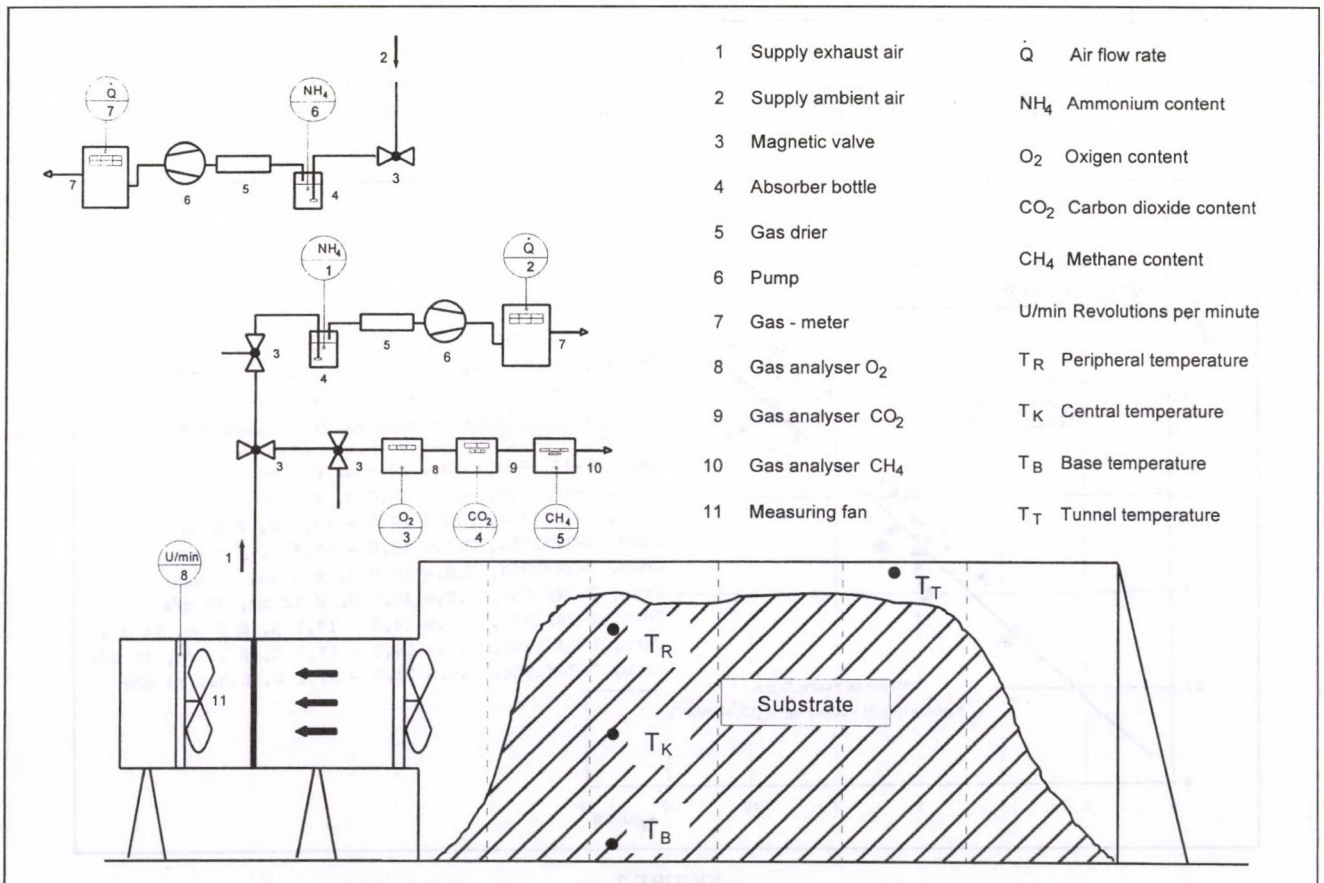

FIGURE 1
 The measuring set-up

secondary aim the different initial materials (such as solid part separated from liquid manure, litter manure) and the different composting (two-step composting, windrow composting) were compared as they effects on the released NH_3 both in the in the complete process and in its last period called maturing phase. As an experiment the hygienisation process, which is an important criterion to judge the technique. As only the quality compost making is applicable in the organic waste processing, the compost quality meeting the regulations of „Bundesgütegemeinschaft Kompost“ was also determined.

Experiments

The investigations were carried in the „Unterer Lindenhof“ experimental yard. The initial size of the triangular cross section clamp were 2.5m x 1.5m x 10m (approx. 20 m³) containing 7.5 to 8 tons material to be composted. The material was the solid part of the liquid manure separated by auger type press. It has homogeneous composition and optimal properties for composting. The approximate dry material content is around 25 % which can be adjusted by the separator. Above the clamp gas permeable cribwork of felt-like material was built with a ventilator at one end of the clamp. This sucks the air from the compost surface with the mean local wind velocity and the O_2 , CO_2 and CH_4 concentrations are determined. The data are recorded by a computer in each half an hour. The magnetic switches which set the path of the measuring gas are controlled by the same computer. The computer collects also the temperature data measured in the whole cross section of the compost, in the air inside felt, and in the surrounding air. In the first week the measurements were accomplished in each 12 hours and so were in the second and third week in each day. In the remaining weeks one measurements was made in each 48 hours. In the investigation series examining the complete composting process the background air NH_3 content is also measured together with the outflow air.

The post process experiment of the composting (number 1 experiment) was governed in two steps. The first, intensive stage came about in a closed, bottom-ventilated reactor through 16 days. Then the fresh compost was „matured“ in clamps for six weeks. In this period the material was turned over in two weeks cycle. The whole composting experiment (*experiment 2*) lasted 3 months when the inversion of the clamp came about weekly in the first three weeks and after then biweekly.

Results

The results gained so far shows that the ammonia emission was kept in low level in both experiment series, whereas the temperature was near 70 °C. The curve shows clearly that the NH_3 concentration of the air sucked from the compost surface decreases while the time precedes. The NH_3 nascency is explained with the high C/N ration of composted material. The ration is reduced from 58:1 to 36:1 in the *experiment 1* and from 64:1 to 42:1 in the *experiment 2*. The oxygen content of the air aspirated from the compost surface was between 19.5-20.7 volume % in both examinations. One can conclude from this that the lack of the oxygen did not disturbed the composting process. In the experiment there was no significant methane nascency which would differ from the environmental air methane content, so that it was possible to eliminate the occurrence of anaerobe zones by the regular rotation and optimal composition of the material.

In the *experiment 2* the temperature so high in the entire cross section of the clamp and long enough that the hygienisation of the material in entire cross section was reached after the seventh week. However, at the end of the two-step experiment low level Escherichia coli and Fekalstreptococci content could be found. In

the hygiene examinations Escherichia coli (E-Coli), Fekalstreptococci (FKS) and Salmonella bacteria contents were determined, carried out in the Animalhygiene Department of The Hohenheim University.

The nitrogen content and the composition of its forms of occurrence changed significantly during the process. In the experiment examining the maturing process during the whole composting process (ten days reactor and six week clamp composting) one could observe Nitrogen loss of 28 % which can be due to the reactor phase completely. In turn the considering only the windrow process the organic material nitrogen content increased by 28 % related to the original material. In both case the ammonium contents were significantly reduced (7 % and 4 %). In the experiments a considerable reduction of the material amount (30-60 %) was observed.

Summary

It can be concluded that the absorption principle NH_3 measurement is suitable method to determine the NH_3 emission directly. The measuring technique developed for clamp composting should be however with high emission (low C/N ratio) material composting. As the different compost making processes and the different material properties significantly influence the behaviour of the process, it is necessary to carry out of the above mentioned experiment. In the course of windrow composting the homogenisation and the complete hygienisation is ensured by the proper rotation rhythm. However, the continuous temperature control is essential. The quality of the samples examined so far meet the prescription of the „Bundesgütegemeinschaft Kompost“ conditions for commercial introduction. The fresh compost produced in the experiments is applicable to use for soil improvement and as fertiliser and the matured compost as black mould.

References

- [1] BEF. (Bundesamt für Ernährung und Forstwirtschaft): Emissionen von Ammoniak-Quellen-Verbleib-Wirkungen-Schutzmaßnahmen. Arbeitsmaterialien des Bundesamtes für Ernährung und Forstwirtschaft, Frankfurt/Main, 1989.
- [2] FRIDRICH, A.: Der Anteil der Landwirtschaft an der Gesamtbelastung der Luft. In : DLG (Deutsch Landwirtschafts-Gesellschaft e. V.): Stoffeinträge aus der Landwirtschaft in die Atmosphäre - Strategien zur Minimierung. DLG-Arbeitsunterlagen, Frankfurt/Main, S 5-11, 1991.
- [3] ISERMANN, K.: Ammoniakemission der Landwirtschaft als Bestandteil ihrer Stoffbilanz und Lösungsansätze zur hinreichenden Minderung. In: KTBL, VDI (Hrsg.): Ammoniak in der Umwelt-Kreisläufe, Wirkungen, Minderung. Gemeinsames Symposium 10. bis 12. Oktober 1990. Landwirtschaftsverlag, Münster-Hiltrup, S.1.1-1.76,1990.
- [4] ISERMANN, K.: Ammoniakemissionen der Landwirtschaft, ihre Auswirkungen auf die Umwelt und ursachenorientierte Lösungsansätze sowie Lösungsaussichten zur Hinreichenden Minderung. Zitiert bei: Enquete-Kommission „Schutz der Erdatmosphäre“ des Deutschen Bundestages (Hrsg.): Schutz der grünen Erde: Klimaschutz durch umweltgerechte Landwirtschaft und Erhalt der Wälder. Economica-Verlag, Bonn,1994.
- [5] MEYER, M.P.: Stickstoffumsatz bei der Kompostierung von Rindermist. Dissertation Eidgenössische Technische Hochschule Zürich,1982.
- [6] SCHUCHARDT, F.: Ammoniakverluste bei der Kompostierung tierischer Exkremete. In: KTBL, VDI (Hrsg.): Ammoniak in der Umwelt - Kreisläufe, Wirkungen, Minderung. Gemeinsames Symposium 10. bis 12. Oktober 1990. Landwirtschaftsverlag, Münster-Hiltrup, S.1.1-1.76, 1990.
- [7] UBA (Umweltbundesamt): Jahresbericht,1993. Berlin,1994.

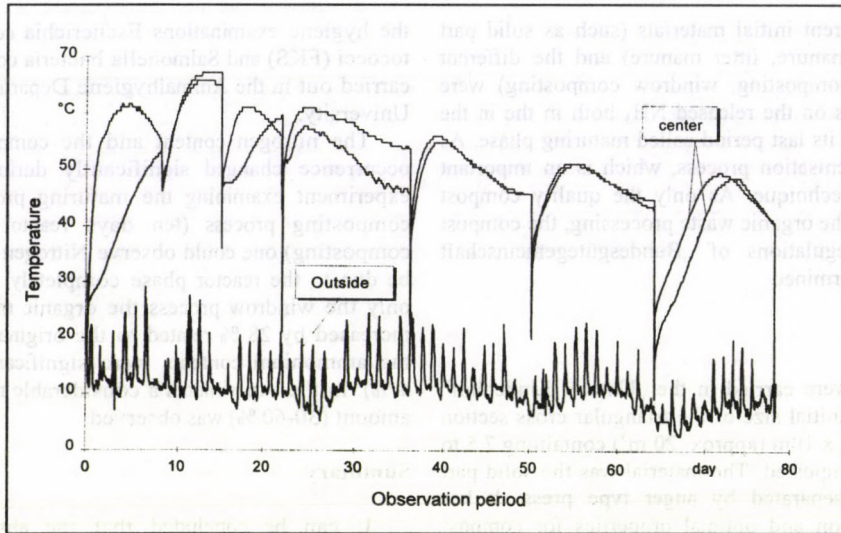

FIGURE 2
Temperature profile of the clamp composting

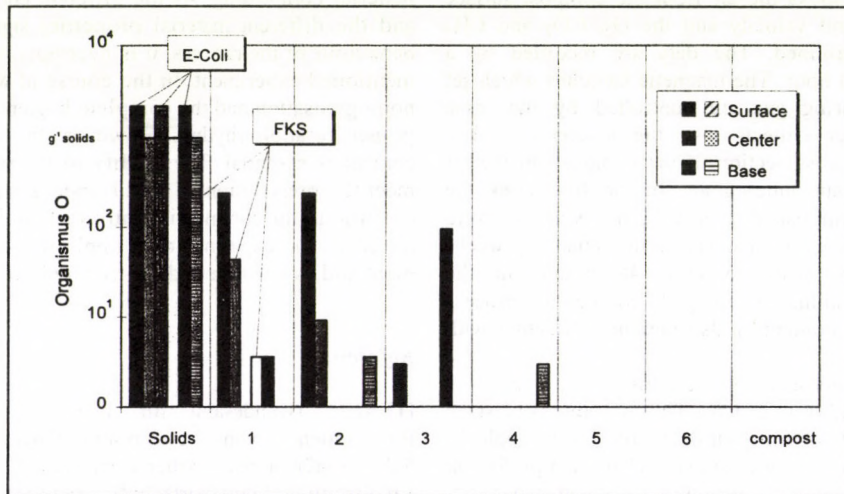

FIGURE 3
Inspection of the material hygienisation

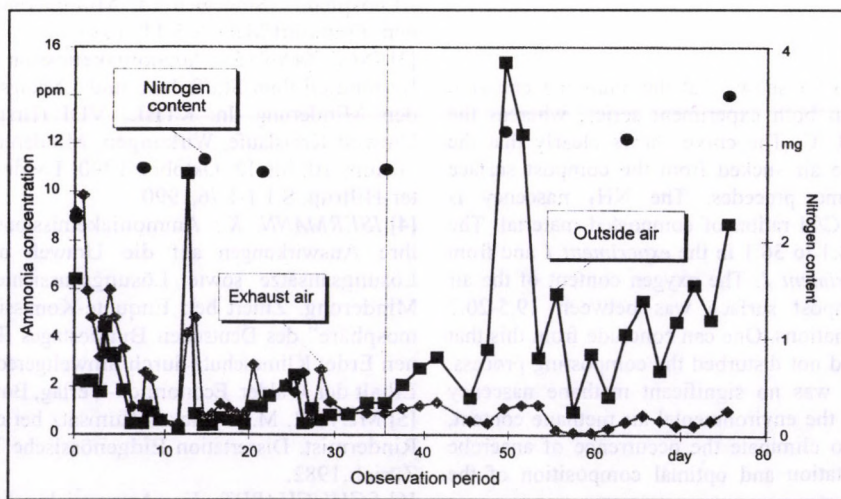

FIGURE 4
The diagrams of the NH_3 concentration as measured in the exhaust and the outside air

COMPUTER IMAGE PROCESSING POSSIBILITIES IN THE EVALUATION OF TILLAGE AND FERTILISER SPREADER MACHINES

Dr. GY. DEMES - S. SALAMON
Hungarian Institute of Agricultural Engineering, Gödöllő
Dr. JÓRI J. ISTVÁN
Technical University, Budapest

The computer image processing was accomplished based on the Machine II real time video digitiser card of FAST Electronic GmbH (Germany, München). The card was installed in an IBM 386 DX personal computer and the general purpose image processing software DigiCell 4.0 version of ASK Ltd. (Hungary, Budapest) as well as a commercial JVC-GA/Ax55 VHS/C video camcorder with a CCD camera were also used. This minimal apparatus makes possible the evaluation of the video records in computer. The modular DigiCell program package run under Windows 3.1 (or higher) and uses pull-down and icon menus. The application is flexible enough and is applicable to measure the image characteristics and parameters of the single video pictures.

The necessary set-up of the image processing is shown in fig. 1. One can see here the IBM 385 DX computer with SVGA monitor and the JVC videocamera mounted on a stage. At the same time there are a few clods placed on the measuring surface for calibration they are also displayed on the screen.

To evaluate the formulations displayed on the screen morphology and densitometry measurements were carried out by means of the DigiCell program. The data collected at the calibration are kept in a text file and they can be converted into spreadsheet applications for evaluation.

For the in situ working quality investigations outside the laboratory a hand cart was made to carry the camera. The cart ensures the near constant distance recording.

Establishing the evaluation method of working quality of soil cultivation machines

The location and shape of clods, plant residues and fertiliser particles is analysed by means of video records assisted by the DigiCell general purpose image processing software.

On the base of principal image processing evaluation it was stated that in the case of the simplified model the individual forms can be separated from each other and they can be evaluated separately and it is possible to determine the characteristic colour differences and so the separated view areas of forms. The coverage rate of the soil mulch can be evaluated by means of the plant residue position analysis and from this the mixing effect of the surface tillage machines. The size distribution analysis can not be realised by means of the DigiCell program as it can not distinct between the contacting same density forms and senses them as single ones.

In order to analyse the size distribution of soil surface clods a program was elaborated which imitates the traditional grid method. In the case of this traditional grid method a frame of size 0.5 times 1 metre is placed on the soil surface, which has a wire net of size 50 mm times 50 mm square. The evaluation is made by counting the number of small squares which cover the surface of a single clod. The number clods found in the whole frame gives the basic data for the determination of clod size distribution. To use computerised image processing the arable land picture is transferred (by means of scanner or video recorder) into the computer. The computer picture is then covered by a properly calibrated net which has a size adjusted free. The surface on the record can be completely evaluated, while using a mask (fig. 2) only the desired part of surface can be also analysed.

After that the program makes a blue point mark if it finds that the individual cell is part of a clod. The cells next to each other are unified as a clod. The program was developed further to be applicable to consider the clod parts only partly filling a cell in order to determine the clod sizes more precisely (fig. 3).

The tools available to us made possible to process only standalone picture frames (photo, video frame) This allowed to carry out only a relatively small number of measurements and evaluation far away from the site.

Within the frame of the research topic the elaboration and the set up of such a system is planned which includes the suitable apparatus and measuring and evaluation system based on that and applicable to the conditions of in situ field measurement conditions. The realisation of such a system needs robust equipment and 12 V DC power supply. Such way there will be possible to carry out large number statistically correct measurements in situ. The further expectable result of the system will be the real time mobile image processing the evaluation of the difference to a given parameter and based on this the adjustment and the control can be applied. The video image analysis measurement and evaluation of the tool functions related to the gauge determination of the energy need in the frame of a complex computer control is planned to reach.

Establishing the evaluation method of working quality of fertiliser spreading machines

The sparing, environment protecting application of fertiliser makes necessary to review the earlier practice. The broadcasting of the single agent artificial fertilisers separately is less favourable than using complex agent materials in one single pass considering either energetic or environmental aspects. That is why the spreading of the bulk blending fertilisers application practice used in the USA for a long time past is expectable. For this the types of the fertilisers should be selected which can be mixed with each other and applied without the risk of separation and the mix ingredients on the soil will meet the agricultural technology needs.

The bulk blending possibility of solid granulates fertilisers is determined on the basis of lateral spreading evenness. The grainy fertiliser ingredients are told to be miscible if the lateral spreading evenness of neither the mix nor the ingredients are below the agrotechnology demand (fig. 4). The blendability or the segregation while blending and spreading are decisively influenced by the shape and mass of the particles. Their combined effect is best expressed by the specific surface area. According to our initial assumption the greater the difference between the specific surface area of particles the particles are less miscible.

The solid granulate fertiliser composition evaluation in accordance with blendability was carried out by the assistance of DigiCell general purpose image processing program. The circumference and area of the individual grains and their specific surface area of the ingredient fertiliser agents by applying the relationships shown in the followings.

The formulas used in the investigations are as follows:

If

$$\left| \frac{r_k}{r_l} - 1 \right| - \left| \frac{o_k}{o_l} - 1 \right| < 0$$

then the volume of the particle is approximated by that of a sphere and so

$$f = \frac{F}{Q} c = \frac{F}{V_g \cdot \gamma} c = \frac{4\bar{r}^2 \pi}{4\bar{r}^3 \pi \cdot \gamma} c = \frac{3}{\bar{r} \gamma} c = \frac{6}{\bar{x} \gamma} c$$

Where

- f = specific surface area (cm^2/g)
- F = surface area of the fertiliser particle (cm^2)
- Q = mass of the fertiliser particle (g)
- r_k = the approximate radius of fertiliser particle calculated from its circumference when circle (sphere) shape is assumed
- r_t = the approximate radius of fertiliser particle calculated from its area when circle (sphere) shape is assumed
- o_k = the approximate side length of fertiliser particle calculated from the circumference of the assumed square shape
- o_t = the approximate side length of fertiliser particle calculated from the area of the assumed square shape
- $\bar{r} = \frac{r_k + r_t}{2}$ the radius of the sphere approximating the particle volume (cm)
- g = density of the given fertiliser (g/cm^3)
- V_g = volume of the fertiliser particle (cm^3)
- x = the average particle size (particle diameter in cm)
- c = coefficient (if the sieve analysis implies normal distribution, its value is equal to 1)

If

$$\left| \frac{r_k}{r_t} - 1 \right| - \left| \frac{o_k}{o_t} - 1 \right| > 0$$

then the volume of the particle is approximated by that of a sphere and so

$$f = \frac{F}{Q}c = \frac{F}{V_k\gamma}c = \frac{6\bar{o}^2}{\bar{o}^3\gamma}c = \frac{6}{\bar{o}\gamma}c$$

Where

V_k = volume of the fertiliser particle (cm^3)

$\bar{o} = \frac{o_k + o_t}{2}$ the average particle size (cm)

(all the other is identical with the previous ones)

Making use of the DigiCell image processing program the particle geometry characteristics were determined for the fertilisers types included in the experiments and taking the density values into account the specific area of the fertiliser particles was calculated. As an example, the results of the components of the most favourable mixture is shown in the following table.

Fertiliser type	Periph. (mm)	Area (mm^2)	Average particle size			Specific area (cm^2/g)	Density (g/cm^3)
			From periph. (mm)	From area (mm)	Average (mm)		
4.MAS	9.95	4.07	2.49	2.02	2.25	26.39	1.01
5.MAP	11.91	5.81	2.98	2.40	2.69	21.60	1.04
6.K	14.07	10.07	3.52	3.17	3.35	15.62	1.15

Where

4.MAS is ammonium nitrate limestone

5.MAP is monoammonium phosphate

6.K is potassium chloride

As for the investigations to determine the conditions of bulk blending of different fertilisers, it can be concluded, that the

distribution evenness on the soil surface of the different ingredient and particle composition fertilisers is influenced by the particle composition, mean diameter as well as the so called average specific area (cm^2/g). The latter is determined on the basis of image processing of particles. The closer the average specific surface area of the different fertiliser types are to each other the higher the probability that the ingredient components lateral distribution will meet the agrotechnology requirements.

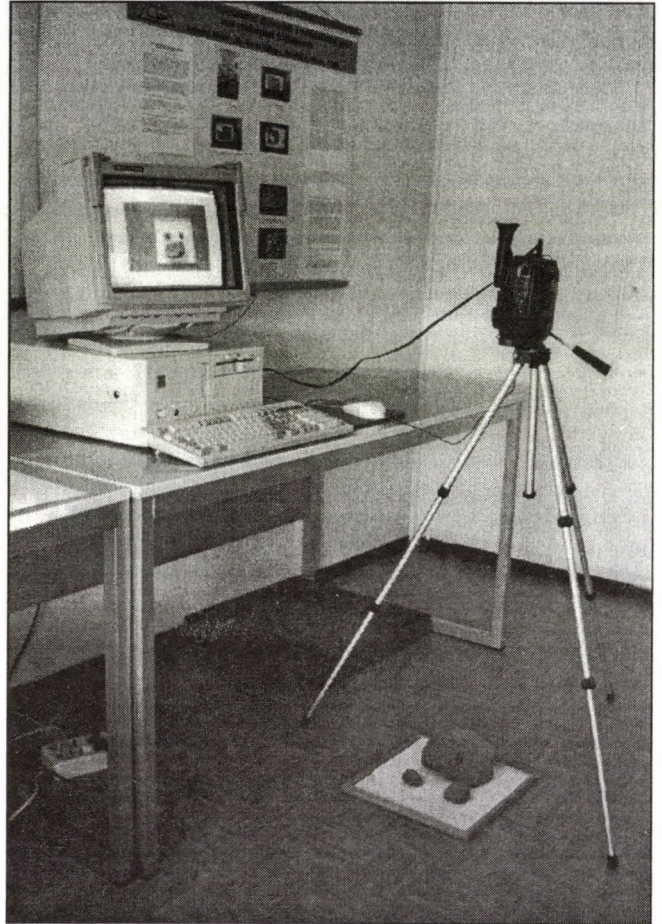

FIGURE 1
Tools of the image processing

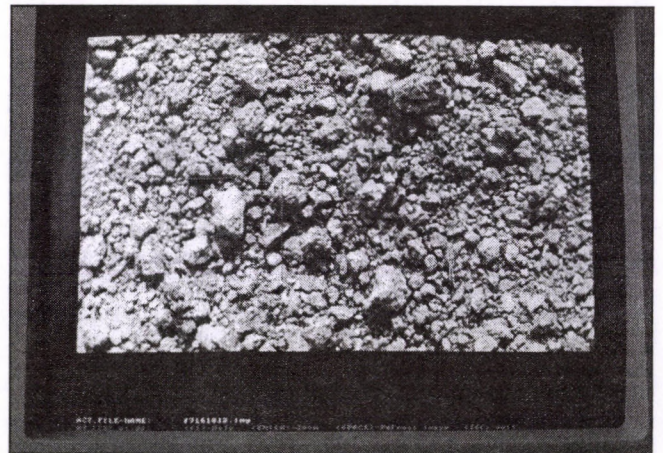

FIGURE 2
The soil surface to evaluate with the mask

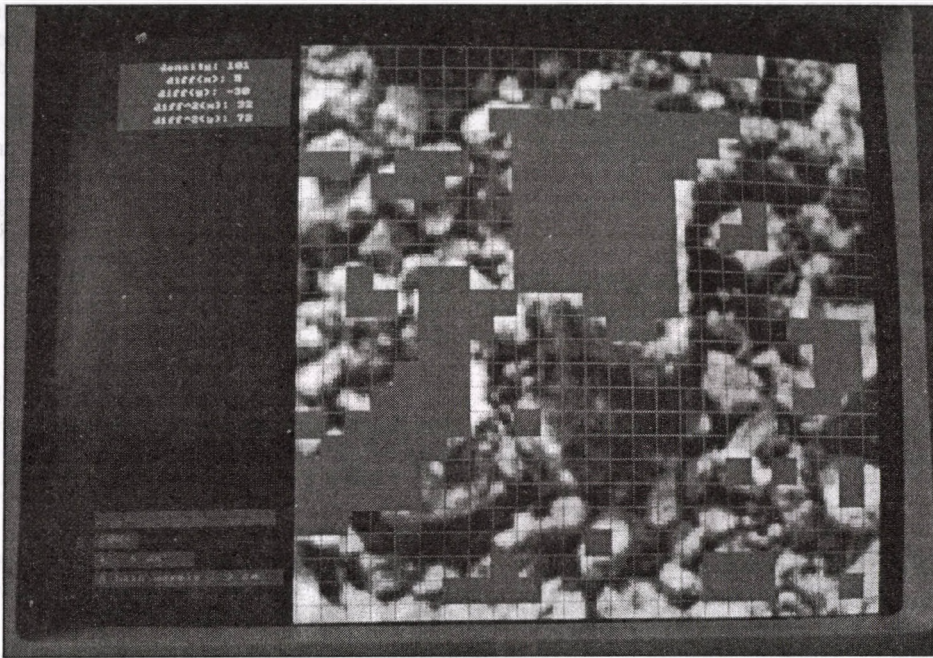

FIGURE 3
The evaluated clods as coloured

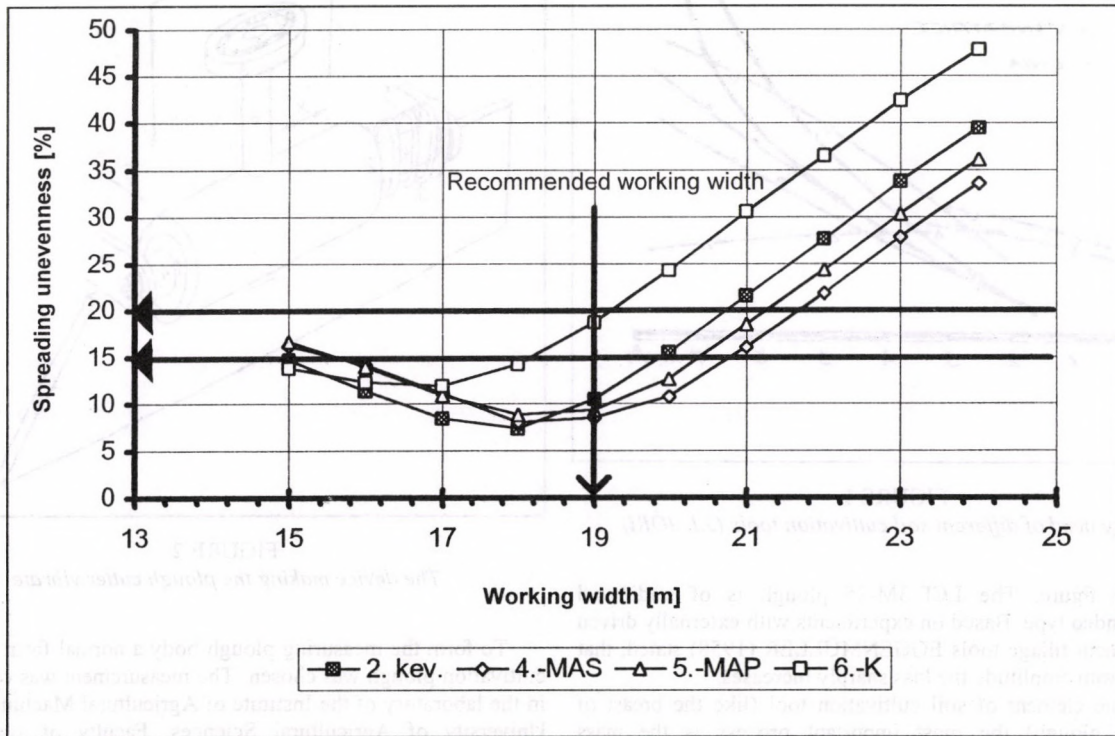

FIGURE 4
The mixture 2 and the distribution evenness of its components

EXPERIMENTS CARRIED OUT WITH ACTIVE CUTTING ELEMENT TILLAGE TOOL

Dr. L. FENYVESI

Hungarian Institute of Agricultural Engineering, Gödöllő

T. MEZEI

University of Agricultural Sciences, Gödöllő

Former experiments, measurements

In the past period there were much development in the field of vibration tillage implements. The whole vibrating tool (plough breast and cutter) energy flow-through investigation was accomplished by JÓRI (1972). It can be concluded from the results (fig. 1) that the energy need of externally moved tools exceeds that of the traditional plough.

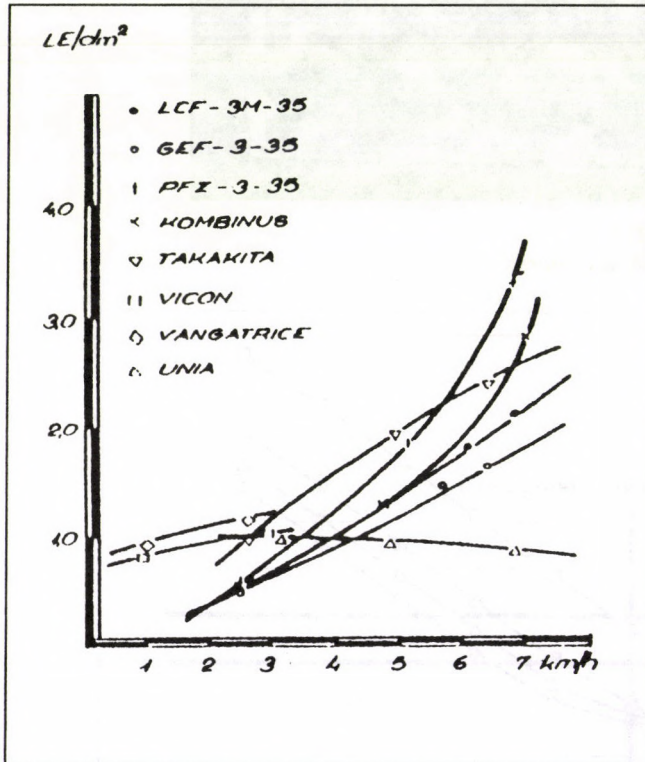

FIGURE 1

Energy need of different soil cultivation tools (J.I. JÓRI)

In the figure, The LCF-3M-35 plough is of traditional semisuspended type. Based on experiments with externally driven active element tillage tools EGGENMÜLLER (1958) stated, that above 3-5 mm amplitude the loss sharply increases.

At some element of soil cultivation tool (like the breast of traditional plough) the most important process is the mass transport. Perhaps that explains that the energy need is higher in the case of vibrating plough. In the case of mold plows, deep looseners and cultivator, where the soil transport is negligible, the active tool will improve the energy balance. Those favourable results can be measured with parameters changing to the soil and machine types. Moderately loose, sandy loams expose and energy optimum for active tool deep cultivation at 36.5 mm amplitude and 9.48 Hz frequency (BANDALAN 1993).

The energy saving of GEF-3-35 suspended roller plough (fig. 1) can be probably due to the more favourable flow conditions.

The digger and rotational tillage machines have higher energy need as compared to the traditional plough with same cultivation parameters. At the UNIA suspended rotary cultivator the

favourable energy characteristic occurs at shallower tillage. In general the small amplitude and pretty high frequency vibration – in sonic range – is favourable, assumably due to the improved friction conditions.

The soil segment separation generated by the soil cultivation tool is recurring, and the separation periods are reduced with the decrease of the tool speed (STAFFORD 1983).

The spectral examination of ploughing shows no characteristic energy transfer frequency (BORSA 1989). So that the resonance frequency of cultivation tool versus soil is determined mainly by the tool.

Development of experimental active cutting element tool

Based on the previous research and development results the aim was to make such a tool, where the motion of the cutting plate of the traditional plough serves the favourable energy saving affect. Such way the breast does not move, so that no resistance increase should be considered. The vibration system is formed by springs giving motion in parallel and perpendicular directions to the plough edge (fig. 2). The system contains no external driving, so that the excitation depends mostly on the spring parameters (selfexcitation system).

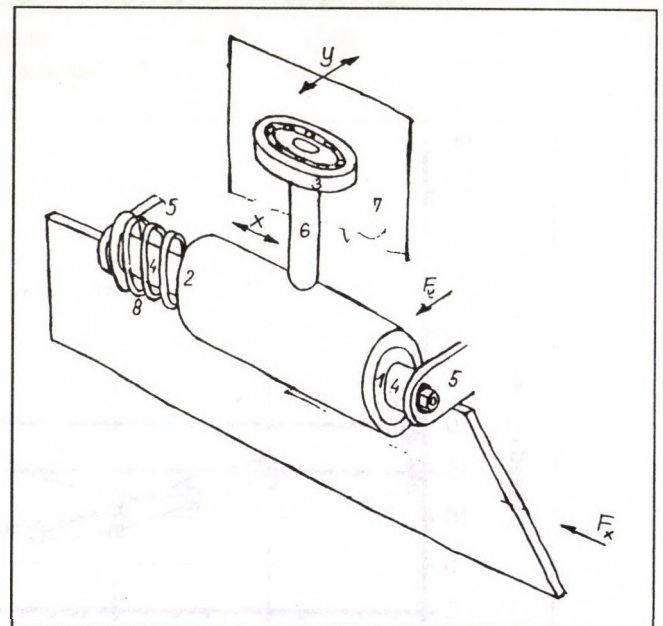

FIGURE 2

The device making the plough cutter vibrate

To form the measuring plough body a normal form moderate cultivation plough was chosen. The measurement was carried out in the laboratory of the Institute of Agricultural Machine Theory, University of Agricultural Sciences, Faculty of Agricultural Engineering. The measuring soil riddle is supplied by measuring devices which can measure the motion and force characteristics. The speed of ploughing and the soil state can be set-up well. The six components of force and the motion velocity were measured by a measuring amplifier of type Hottinger DMC 9012. The data processing was made by means of a software called BEAM.

To realise the to directional oscillation the machine element shown in figure 2 was made. Actually, the part fixes the cutter plate to the plough breast making use of (1), (2) slide and (3) roll bearings. The bearings made of ZX 100 teflon-like material slide and rotate on the shaft (4). The shaft is mounted on the breast with the bails (5). The support shaft (6) roller bearing run on a plate (7) fixed to the breast, hindering the tilt of the blade. The

plate (7) can be rigid or elastic, in which case it makes possible the oscillation perpendicular to the edge. The edge directional vibration is generated by the cylindrical spring.

The measuring results

The moderately adherent sandy loam soil (of 30-32 % Arany adherence number) was made to lose, move and roll to achieve the original state. The measurement was made at 1 m/s speed. The width of the soil riffle allowed to complete three drag at once among which one was made always with rigid tool as control experiment, the two other were made with oscillating blade at same set-up. The pulling force ratios were measured to eliminate the alterations of the individual set-ups.

The results of the edge direction blade vibration are shown in fig. 3. One can recognise the pulling force rise at small spring

constant values (2-6 N/cm). According to the evaluation that is caused by the large displacement (30 mm) of the plough blade as uncovering the fixing parts and resulting additional resistance (the side directional force was outward to the furrow wall. The error can be eliminated by using jointer (as it is being made recently with the several body measuring plough). In spite of the design fault, a considerable traction force saving is reached at higher spring constant values (of 10-15 N/cm). The blade acted as a rigid tool above 20 N/cm spring constant value.

By their average values two set of measurements is shown in figure 4 belonging to the blade motion perpendicular to the blade edge. The greatest traction force reduction is experienced at the 15-25 N/mm range of spring constant.

There are planned to carry out further energy measurements after solving the mentioned construction problems by using several body arable land experiments.

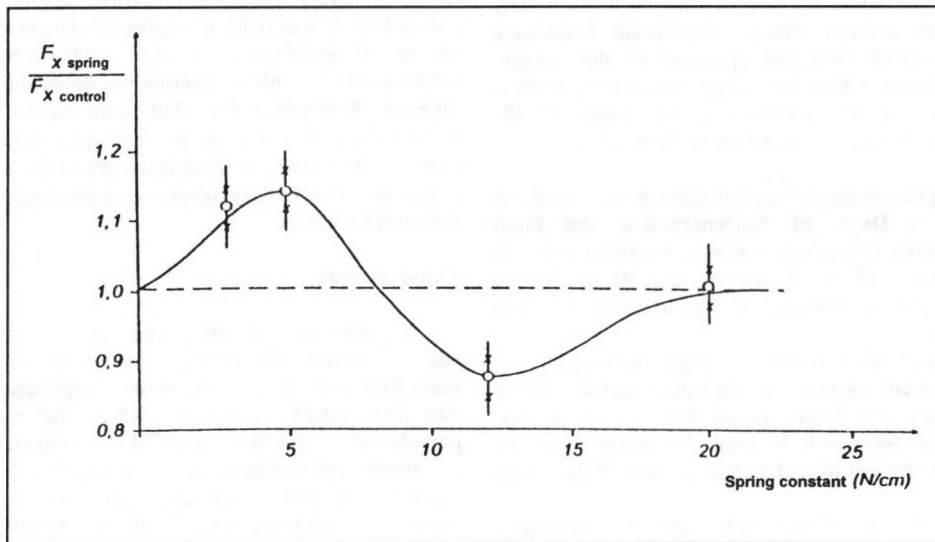

FIGURE 3

The formation of the relative traction force with the edge directional oscillation of the plough blade

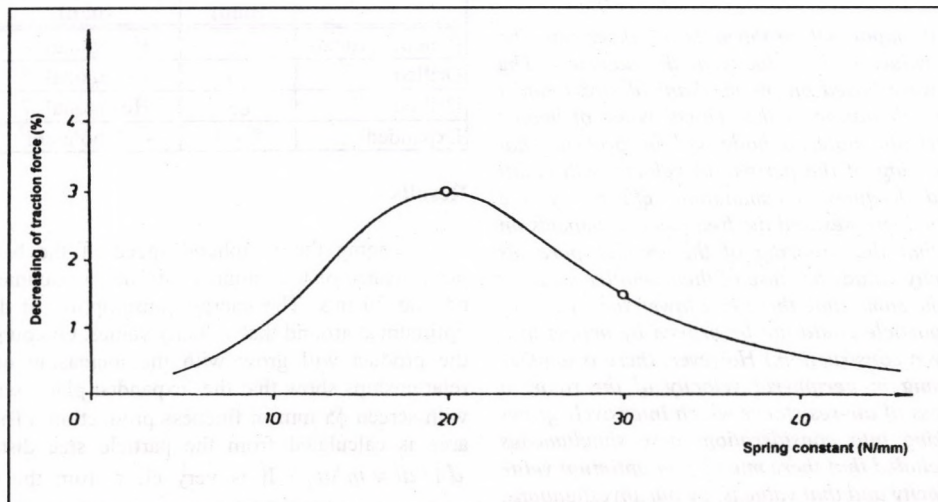

FIGURE 4

Specific tractive force decrease when the plough blade oscillates perpendicularly to the cutting edge

RELATIONSHIP BETWEEN SCREEN SURFACE GEOMETRY OF HAMMER MILLS AND ENERGETIC PARAMETERS

M. DOUBA - Dr. L. FOGARASI - Prof. Dr. P. SEMBERY
University of Agricultural Sciences, Gödöllő

Grinding Cereal Grains by Hammer Mill

The hammer mills are widely used for comminution of very different materials in many industries and specially in the agriculture or the feed mixture manufacturing for grinding cereals and other feed components. This 'popularity' is quite understandable because their construction and control is very simple and the comminution range, independently of the size and characters of the material to be ground, could be relatively wide. (In some countries hammer mills are called as 'universal grinders'.) Despite of the constructional simplicity and the researches of many decades, the engineering includes mainly practical experiences without suitable theoretical knowledge applicable for the construction and operation of the hammer mills. The other problem is that the energy use of these mills is extremely bad. By certain calculations, the value of the theoretical efficiency of grinding is not more than 1 % (!) at any type of machine.

Series of investigations during several years were carried out in the laboratory of **Dept. of Agrienergetics and Food Engineering** (University of Agricultural Sci., Gödöllő) using an experimental hammer mill to determine the effects of the material, kinetic and constructional parameters on the comminution process.

The most important result of the investigations was that we realised the role of the comminution on the screen surface. That is why **screen geometry** was improved on the base of the test results and an attempt was made to grow the sharpness of the edges of the screen holes and the active surface area of the screen of the hammer mill.

The conventional and theoretically specified **energetic parameters** were measured, calculated and examined, too, and constructed into diagrams.

Effect of the Peripheral Velocity

One of the most important problem is to determine the required or correct value of the velocity of the hammers. The early investigations were based on the mechanical stress model formed by Hertz for calculation of the critical value of impact speed at which a certain material body will be broken. That means that the increasing of the peripheral velocity will result more intensive and frequent comminution effects by the increasing of the actual stresses and the frequency of impacts on the one hand and that the breaking of the smaller particles requires higher velocity values because of their smaller mass on the other hand. (In the same time there is a lower limit value of the size at which a particle could not be broken by impact in a hammer mill of a given construction.) However, there is another effect of the increasing in peripheral velocity of the rotor: a higher value of the loss of air-resistance which intensively grows with the speed. Taking into consideration these simultaneous effects, it can be concluded that there must be an optimum value of the peripheral velocity and that value is, by our investigations, lower than 90 to 100 (110) m/s determined by certain researchers at grinding of the usual cereal grains.

Particle Size Distribution

The particle size distribution and its parameters were determined by sieving analysis and different calculations based

upon the conventional and the new accepted models. The empirical distribution curves do not really fit to the known functions, the regression equations can be accepted as the best estimations of the relation $D-x$ (where x is the particle size of fraction and $D=D(x)$ is the mass ratio of the particles (grits) with size smaller than x). The cause of the deviations can be that there are expected top and lower limit values (which can be concluded from the top and the lower bends of the curves) in the comminution range of particle size. Of course, the errors of the sieving analysis have to be expected here, too.

Energetic Parameters of Grinding

During the tests the conventional energetic and functional parameters were measured and determined, i. e. the **total power requirement**, **power of idle running** (losses), **mass rate** and **grits fineness** (nominal particle size and specific surface area of the product), **specific energy consumption**, and constructed into diagrams. Using the modern theories elaborated by the earlier researchers of that field, the collected data were transformed into specialised parameters for the comparison of the different constructional solutions, operational states and materials, i. e. the diagrams P_n-dA/dt and $v-dA/dt$ were constructed for every test series (where P_n is the **net power** requirement of the mill, dA/dt is the surface **area growing intensity** of the comminution and v is the so called **energy level** (net energy per the produced new grits surface area)).

Experimental

The experimental set-up (fig. 1) is suitable for measuring and/or recording the next parameters of the grinding process: **mass flow rate** (kg/s or t/h), **power requirement** (kW), **particle size distribution** of the product at different feeding rates, **peripheral velocities** (R.P.M.), **materials** or **material conditions** and **screen sizes**. A hammer mill type Zenit Junior of medium size and performance (less than 2 t/h) was used in laboratory conditions. Screens of conventional construction and new special designs were tested as it follows:

	Size of Hole (mm)	Distance btw. Hole Centres (mm)	Active Area of Screen (%)
Punched, round	φ5	Hexagonal, 8	33
Drilled	φ5	Hexagonal, 8	33
Drilled	φ5	Hexagonal, 7	44
Expanded	8 x 3	4.17 hole/cm ²	62

Results

Changing the peripheral speed of the hammers, the mass performance of the hammer mill has a maximum value between 65 and 70 m/s. The energy consumption of the mill shows an optimum at around that velocity values. Of course, the fineness of the product will grow with the increasing of the speed. The relationships show that the 'expanded plate' screen is equivalent with screen φ5 mm in fineness production. (The specific surface area is calculated from the particle size distribution data, so $dA/dt = \dot{m}\Delta a_f$) It is very clear from the diagram that the 'edges' of the screen holes play an important role in the comminution and the energetic properties of the 'expanded plate' and drilled screens are better. Moreover the active surface area of the screen 5 d2 is bigger than the conventional screen φ5 or 5 d1!

The constant lines as energy levels (fig. 2) prove the same and it has to be remarked that the operation ranges do not cover each other at all.

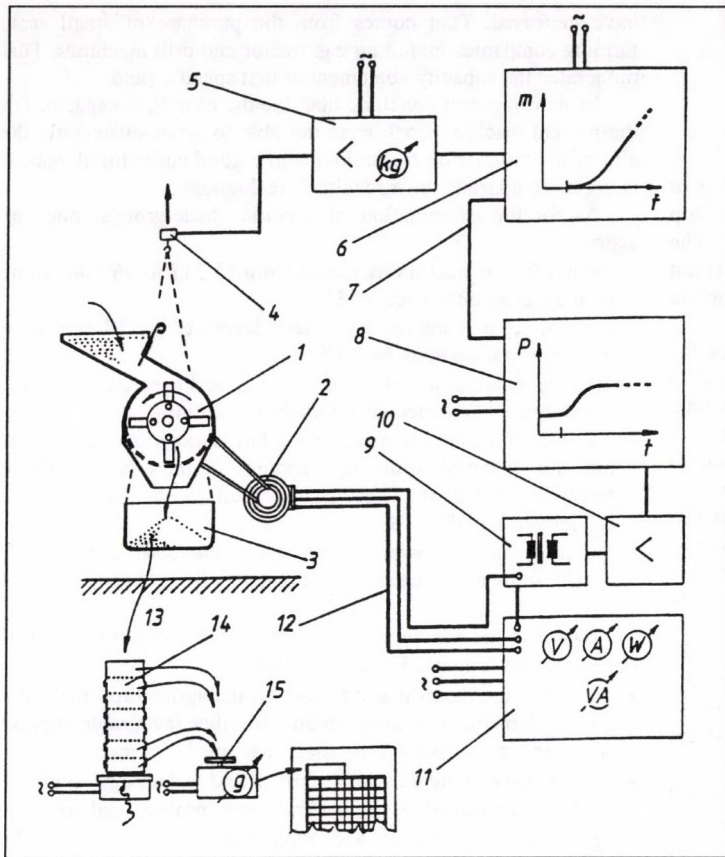

- 1 - hammer mill;
- 2 - driving motor with multidegree V-belt transmission;
- 3 - grits-collecting box;
- 4 - electrotonsiometric sensor for measurement of weight;
- 5 - amplifier-transmitter;
- 6 - potentiometric recorder (line-plotter);
- 7 - synchronising cable;
- 8 - potentiometric recorder;
- 9 - measuring transformer;
- 10 - amplifier-converter;
- 11 - compact electric measuring unit;
- 12 - three-phase power cable;
- 13 - grits-sample;
- 14 - test sieve;
- 15 - quick weigh

FIGURE 1
Test system for hammer mill experiments

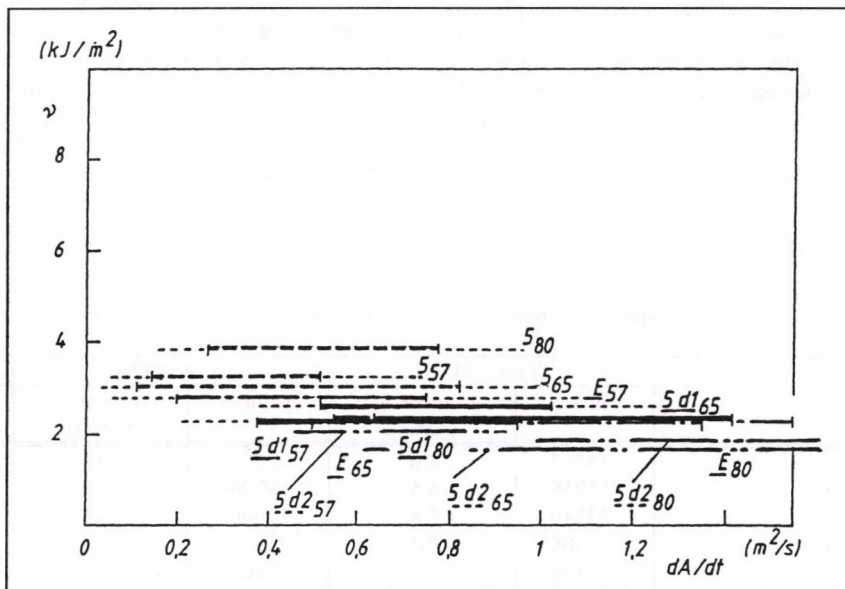

FIGURE 2

Relationship between the **surface production intensity** dA/dt and the **energy level** v (energy requirement specified by new surface area) of the hammer mill on different screens and peripheral velocities, grinding storage dry corn

$$\frac{dA}{dt} = \dot{m} \Delta a_f \quad (\text{m}^2/\text{s}) \quad \text{where } \dot{m} : \text{mass flow rate (kg/s); } \Delta a_f : \text{new specific surface area of grits (m}^2/\text{kg)}$$

$$v = \frac{dP_{net}}{d\left(\frac{dA}{dt}\right)} \quad (\text{kJ/m}^2) \quad \text{where } P_{net} : \text{net power requirement (kW)}$$

v - energy level (net energy requirement specified by new surface area) (kJ/m^2); 5, 5 d1, 5 d2, E_{57, 65, 80} - conventional (punched), drilled screens of $\phi 5$ mm and the expanded plate screen at peripheral speed of 57.5, 65, 80 m/s; dA/dt - total new surface area of the grits formed in unit of time during the comminution (m^2/s) (surface production intensity)

EVALUATING THE TECHNICAL PRODUCTION CAPACITY OF AGRICULTURE

Dr. J. HAJDÚ - Dr. Z. PESZEKI - Dr. I. TAKÁCS
Hungarian Institute of Agricultural Engineering, Gödöllő

In the course of the transformation of the agriculture great changes has come about the state of machine stock, ownership structure, machine usage practice and the operations, as well. The aim of the research to resurvey the changes of machine stock and production capacity and to examine the relations of production tasks and the machine capacities.

In the elaboration of the topic the present potential of the machines and implements have been examined and compared to the ten years ago stock and capacity figures. The nominal capacity of the complete stock is corrected by factors characterising the wearing out and technical state of machines, and so determining the real capacities in general and for each groups.

The investigations accomplished, and the evaluations produce the result, that the machine stock decreased by more than 6 % in the examination period resulting also a fall in the machine capacity. Even a greater capacity fall presented itself due to the machine ageing and wearing out. Whilst ten years ago the machines were able to produce 76 % of their nominal capacity, the relevant figure is only 60 % now. The average operation time of the implements was reduced from 940 to 670 working hours.

The total machine capacity reduced by 44 % in the last ten years.

The grain and green produce dryers and tractor operated transport machines have the worst state. The capacity of nutrition material application and dryer machines decreased considerably, but there was a great corruption to the capacity of combine harvesters, other self-propelled machines, tillage tools, planting and fodder harvesting machines, too. The situation resulted only in little tension in the production technologies, because the production task volume decreased in all; for example, the fertiliser application was reduced dramatically and the volume of tillage work abated and so did the harvested produce volume due to the production cut. In the case of some machine types the stock

have increased. That comes from the purchase of small scale farming companies including e.g. tractor and drill machines. That moderated the capacity abatement of that specific field.

In short one can conclude that due the near 50% capacity fall the present machine stock were not able to serve sufficiently the aim of the production technologies in a good agricultural year. It is urging to upgrade the agricultural technology.

As for the examination of specific stock groups, one can state:

- the number of tractors increased from 55 317 to 66 500, while their capacity decreased by 35 %;
- the number of combine harvesters decreased by 28 % and so did their total capacity by 40 %.
- the only stock groups of what the stock and capacity increased, are self-propelled special and loading machines;
- the most considerable quantitative fall is experienced with the nutrition material applying machines (manure and artificial fertiliser spreaders). Their number fell to the half and the capacity to less than 18 %;
- the most aged apparatuses are the grain and green fodder dryers, so that their capacity abatement is the most significant.

Based on the accomplished examinations and evaluation it is necessary and suggested to act as follows:

- To ensure the renewal and replace of the agricultural machines and implements new loan, credit and other favourable support schemes are necessary to promote machine investments.
- The capacity of the existing technical and technology condition could be improved by better and more professional machine operation maintenance and reparation, but it needs the availability of a suitable machine operation maintenance system - method and network - which corresponds to the extremely aged technique.
- It is necessary to elaborate a new power and implement machine system what matches the oncoming years agriculture, when the EU adherence conditions are considered fitting the functional and special machine aggregate systems to the new production aims.

Table 1
Capacity change of the most important plant production machines (Years 1985 and 1994)

Item (machine type)	Year 1985		Year 1994		Capacity change
	Number	Average age (years)	Number	Average age (years)	1994/1985 (%)
Tractors	55317	7.0	66500	9.8	64.95
Combine harvesters	12016	6.5	8700	8.9	59.67
Trucks	33240	5.5	28000	8.7	71.51
Self-propelled special	5500	6.5	5400	9.2	45.11
Self-propelled loader	4206	6.5	7100	8.8	138.98
Self-propelled plant protection	140	7.0	170	9.2	104.19
Tillage	112000	7.0	99600	9.3	53.24
Nutrition applying	12600	7.0	6500	10.0	17.69
Plant protection	8800	7.0	8500	9.2	59.14
Sowing and planting	16896	6.5	16762	9.4	64.42
Fodder harvesting	34000	6.3	38000	8.8	56.16
Other harvester	2800	8.0	2600	10.4	61.22
Grain dryer	1856	10.5	1800	4.5	39.68
Green fodder dryer	323	12.5	250	17.0	17.80
Trailer	86154	9.0	75000	12.5	58.73
Pulled and fixed loader	9600	8.0	8500	11.6	55.35
Bus	4780	6.0	2800	8.4	30.02

Table 2
Power machines of small scale farms

Item (machine type)	Volume		
	Countrywide (number)	In small companies (number)	Ratio (%)
Tractor	67500	38500	57.0
Truck	28000	4670	16.7
Combine harvester	8700	1190	13.7

Table 3
Stock of implements

Implement description	Volume		
	Total (countrywide) (number)	In small (number)	scale farms (%)
Trailer	7500	29680	39.6
Plough	39800	25640	64.4
Seed bed preparing	39800	27240	68.4
Sowing	18400	12900	70.1
Mower	18700	11970	64.0
Windrower	10300	6370	61.8
Cultivator	19900	11970	60.1
Baler	7100	4380	61.6
Sprayer	8500	5920	69.6
Fertiliser spreader	4900	3036	61.9
Manure spreader	1600	1124	70.2
Giant baler	4600	2480	53.9
Loader and grabber	15600	4130	26.4
Container trailer	7500	1050	14.0

EXPERIENCES OF THE CONSERVATION CORN PRODUCTION AT 1995.

Dr. S. SOÓS - Dr. I. SÖRÖS
Hungarian Institute of Agricultural Engineering, Gödöllő

In the past years some experiments have been carried out to establish the technological and technical bases of the Conservation Corn Production. In connection with this the existing technical solutions, machine modifications and developments were sought and the lacking machines were bought.

The technical aggregate was mainly established on our own resources adapted to the already existing home machine aggregates. On this basis, production technology experiments were carried out to judge the home applicability of corn production technologies.

The United States is considered as the base of the adaptation experiments, where four different corn production technologies are in usage, such as mulch, band, ridge and direct planting. Till the beginning of 1995 the nonploughing technology was used, like cheesel plow, subsoil loosener and heavy disk. Those experiments applied seeding in mulch and band planting technologies. The examinations are included in the previous years reports of us.

The other two nonploughing corn production technologies which has not been examined in detail so far are the direct planting and the ridge ones. The investigations started in this year (1995).

The aim of this was to modify the Planter of type KÜHNE-CASE-IH-Cyclo-800 to applicable to use for direct planting and ridge planting. Using such type of set-up production technology experiments was accomplished in direct planting and in starting the technology preparation for ridge cultivation with building up ridges. So that our this year investigations focused on the direct planting technology.

Another goal of the 1995 year investigations was to carry out further technology experiments with the nonploughing corn production technologies in order to practical set-up and yield registration. The Tillage equipments had been: CONSER TILL-4,2 cheesel plow and KÜHNE-CASE-IH-10-770 heavy disks in 1995 for the nonploughing corn production technology experiments.

Direct Planting

The base of the corn direct planting technology is that no cultivation or other operation is made from one corn harvest to the next year springtime planting of corn. So that the planting is accomplished in the autumn remainders mulch left to the spring planting made with special or traditional planters mounted with additional adapters.

The direct planter – compared to the traditional one – should meet two additional functions, such as:

- It has to cut the mulch material through to open the uncultivated hard, compacted soil for the seed;
- It should make the proper contact between the seed and the soil to assist the start of the germination and the growing of the plant.

Ridge Planting

The base of the Ridge method is the bulked out soil profile where the rows are planted. This technology is basically differs from the direct planting, moreover it is almost the opposite, especially when the need for the building and rebuilding of the ridges is taken into account. The large volume soil transport of these technology operations are accompanied with considerable weed control – which is sufficient in some extreme cases, which

could be produced by chemical treatment at the direct planting technology.

In the case of ridge method special within-the-row moving tractors and other machines are necessary. Considering the narrow band, between the rows in the case of large mass machines (like tractor, combine harvester) narrow twin wheels should be used on the axle carrying the weight of machine, otherwise only one wide tyre would tread off the ridges. In the case of thin twin wheels one wheel goes in one spacing and its pair in the next one.

There are two basic technology version of ridge method. At one of them the tillage is made by the destroying and the rebuilding of the ridges with shifting large amount of soil – which makes possible considerable mechanical weed control, as mentioned earlier. The other – less generally known – version uses direct planting on the top of the ridges without destroying and rebuilding them (direct ridge technology). Of course in this case only the chemical weed control is applicable, similarly to the Direct Planting.

In the former years we had some experience with the nonploughing corn production technologies with direct planting as made it known previously. The trial field of the 1995 year experiences was chosen based on this experience. The soil of these field is moderately adherent, sandy loam, where the direct planting may be considered the most. That was not the only aspect of the selection, because the extensive corn production without ploughing including direct planting should be used on less valuable soils where the cost of intensive production methods would not be returned.

In spring there were no operation made on the selected area which was chosen for direct planting and ridging. The corn produced of the former year was harvested by combine harvesters with stalk chopper adapter.

The earlier tested two version technologies of the former year experiments continued. They gave already good results. At those technology soil preparation was made by the CONSER-TILL-4,2 cheesel plow and the KÜHNE-CASE-IH-10-770 heavy discs just before planting.

The basic machine selected for the direct planting and also for the ridge planting technologies was the KÜHNE-CASE-IH-Cyclo-800 which is manufactured and used widely in Hungary.

For the planter the coulters were bought from the United States and some of the necessary parts were manufactured by ourselves based on the earlier experiences of us with the direct planting.

The eight and twenty-five waves discs were bought separately whilst the thirteen waves discs were borrowed from the set of the YETTER WTS 6700 Coulter-cart which had been purchased for autumn wheat direct seeding.

Two pairs of each different type discs were fixed on the planter and later plant counting was used to figure out the effect of different coulter discs on the number of plants (serial I). The distribution of the discs on the drill machine – according to the course – were as follows:

- | | |
|-------------------------|-------------------------|
| – first and second rows | twenty-five waves discs |
| – third and fourth rows | eight waves discs |
| – five and sixth rows | thirteen waves discs |

In the experiments serial II the same type eight wave discs were used in front of each planting elements, but the closing units of the planting elements were mounted differently in some rows. In this serial II experiments the effect of the different closing set-up units on the plant number were examined.

In such a set-up the original factory closing units including twin seed covering discs and rubber compaction wheel were mounted in the first four rows of the drill machine.

In the fifth row the seed covering disc were replaced by a home-made plastic seed firming wheel, while the original rubber closing wheel at the back of the planting element was still kept.

In right sixth row of the planter even this rubber closing wheel was abandoned and replaced by a significantly larger mass inclined home-made metal twin closing wheels.

In the moderately adherent sandy loam soil the different variations of the drill element set-up of KÜHNE-CASE-IH-Cyclo-800 planter were investigated as they influence the number of plants and the yield compared to the traditional corn production (ploughing) technology.

It was stated that the different type wavy discs mounted in front of the planting elements (serial I) implies the best result was reached in the plant number of population by the thirteen wave disc as for the given soil conditions and the applied speed. When this was used, a similar – or even higher – number plant population were experienced as that of the (ploughing) conventional production method. In the case of other wavy discs the number of plants of the population was lower.

From all this one can conclude that the proper selection and application of wavy coulters plays significant role.

When the planting elements were mounted with different closing elements – such as traditional set-up (of seed covering disc plus rubber closing wheel), plastic seed firming wheel with rubber closing wheel, plastic seed firming wheel with twin

compaction metal wheel –, the best result was produced by the plastic seed firming wheel and the twin metal closing wheel unit.

The Direct Planting gave lower yield when compared to the traditional (ploughing) production in each (I and II) serial. In the serial I it can be due mainly to the significantly lower number of plants.

In addition to the comparison of the direct planting, conventional (ploughing), and soil loosening technologies, in the case of the latter two the experiments for comparison of the yield one can conclude that the nonploughing technology shows up better result both in the plant number and yield first of all with the CONSER TILL cheesel plow. The other soil preparation carried out with disc harrow the number of plants was higher, and the yield is lower in respect to the conventional (ploughing) technology.

The direct planting experiments are rather aimful to continue with the waving discs and plastic seed firming wheel as well as twin soil closing wheels mounted planting units at different soil and moisture conditions. It may be reasonable to construct stronger, higher pressure closing wheels.

On the land area of the direct planting the ridges are shaped and the ridge technology test may begin from 1996. The ridges of 36.9 centimetre height formed in two pass the SUKUP 660 High Residue Cultivator are good basis for planting.

Advantages and other aspects considering the Direct- and Ridge Planting Technologies
(Source: USDA SCS Program Aid No. 1416)

<p>Direct Planting (No-Till, Plant-Till, Slot-Till)</p> <p>Advantages</p> <ul style="list-style-type: none"> – Greatly reduces soil erosion. – Practically all the stalk residue is left on the soil surface, so that the soil is saved against the harmful effect of the wind and water erosion. – The soil surface stalk residue saves the precipitation from flowing away and keeps the moisture more. – The investment expenses are reduced as there is no need of plough, disc or field cultivator. – Time and fuel are saved as fewer passes of heavy tools are needed. In addition the abandonment of those passes will reduce soil compaction. – It serves the organic material accumulation. – The previous year stalk residue standing on the field and reduces soil erosion gives shelter for the wild animals, reduces evaporation and grasp the snow what means more precipitation. – Using the same track reduces soil compaction. 	<p>Other aspects to consider</p> <ul style="list-style-type: none"> – Well skilled driver/operator is necessary. – Need to use chemical weed control laid on herbicides. – For the good results the fertiliser should be used in bands or by injection. This applies mainly to the nitrogen fertilisers.
<p>Ridge Planting</p> <p>Advantages</p> <ul style="list-style-type: none"> – Greatly reduces soil erosion as all the stalk residue is left on the soil surface. – As the stalk residue is placed in the furrows less stalk residue disturbs the planting. – Due to the less stalk residue and the higher level ridge the surface is dried and warmed up earlier in spring than the even soil surface, so that earlier planting is possible. – The stalk residue helps traction of the tractor on wet areas. – The top of the ridges offers optimal seed-bed. – The previous year stalk remains standing on the field and reduces soil erosion, gives shelter for the wild animals, reduces evaporation and grasp the snow what means more precipitation for the soil. – The chemical weed control should be used in bands what reduces its amount and the cost of protection as compared to those of total surface application. – The aim of the cultivation is partly the weed control and partly the building of ridges. – Using the same track reduces soil compaction. 	<p>Other aspects to consider</p> <ul style="list-style-type: none"> – Special ridge planters or additional units are necessary. – The width of tyres and the track of the tractor, fertiliser spreader and combine harvester should match the ridges and furrows. – Ridges can cause trouble in the turning place.

ELEKTROSTATIC SPRAYING RESEARCH AT APPLE PLANTATIONS

I. KALMÁR - E. PETRÓ

University of Agricultural Sciences, Gödöllő
College of Agricultural Engineering, Mezőtúr

Summary

Nowadays, the uses of chemical saving, environment friendly and plant protecting methods are spreading wide in the intensive fruit-gardens. In Hungary, we have tested the application of the MARTIGNANI kwh electrostatic drop-filling spray machine at some apple-plantations.

In summary, we found the above-mentioned machine applicable in traditional fruit-gardens. Beside the optimum research conditions, the according to figure savings and advantages mentioned by the manufacturer can be probably reached, but there are needs for further testing.

Today, almost everybody has come to the conclusions that the world's food-products need cannot be produced without chemical plant protective, even in the near future.

In order to reach the desired biological effect with the plant protecting methods, the spray fluid should be got to the plants:

- in due season
- in correct quantity
- at the right place, and
- in appropriate distribution

Spraying is also a biological, chemical, technical and technological problem. The representatives of biological and chemical sciences have been coming up with newer and newer environment sparing chemicals in the market, while there have not been sensational new solutions in the tool-system of getting the fluid to the plants, and in technology for the past few years. A spraying machine renders more than ten times of its value in the spraying process, so the 'chemical-economical' sprayers become more valuable.

In Hungary there are a lot of spraying machines, amongst which are the electrostatic drop-fluid spraying machines. The main advantage of this method is that the electrostatic fluid reaches the exact surface it is directed to. This is why a small quantity of chemicals is enough and the expense reduce and environment sparing effect of this is significant. The uses are hindered by the complicated technical solutions, the conditions of operation and maintenance demanding more care, and by the relatively high costs of machines as well. The applied technical solutions constructed by the MARTIGNANI high electrostatic drop-fluid spraying machines means a lot of saving at several areas for the farmers, including the significant chemicals saving.

The manufacturer enlists the following saving and advantages in its catalogue:

- chemical savings: up to 35 %
- time and labour needs: 65 % favourable
- water savings: 90 %
- fuel savings: 40 % approx
- environment: sparing method
- simple machine design
- easy settings
- high level safety of operations
- minimum maintenance need.

The results of examination by several global research institutes and conference materials, as well as the other not mentioned publications also show the advantages of spraying with this machine, if not all of the mentioned in the brochures.

The evaluation data by the MARTIGNANI company can also serve as references. Out of the nearly 10000 pieces of spraying machine sold in the world, 1400 pieces are Italian, and up till now the testing results have shown that beside the decrease in chemical utilization economical spraying can be obtained, too.

MARTIGNANI machines have been applied in intensive fruit-gardens up till now. Before the selling of these machines in Hungary, we examined them in rare standing fruit-plantations.

Summary of the testing results

In a given economy and planting culture „close-fitting” machines are used in intensive vineyards and fruit-gardens. The aim of our testing was to determine whether the MARTIGNANI kwh spraying machines are applicable in the domestic fruit-gardens and if they are of greater advantages to the traditional axial-ventillator machines.

Place of examination: Research Station for Fruit Growing, Újfehértó.

Time of examination: 11.10.1994.

Tested area: 5 m lane-distance, 4 m plant distance, 3.5 m high, 3 m crown-diameter slim apple-plantation.

Indicating material: Lumogén (BASF).

Research process: with given spraying parameters with traditional and electrostatic drop-fluid spraying machines applied in the spraying of one-one lane of the fruit-garden, taking of samples, laboratory evaluation.

Note: The parameters of spraying and machine setting in the case of the electrostatic and traditional machines were determined by the representatives of the commercial firms.

Sampling: 3 levels, 4 segments, 50-50 pieces of leaves

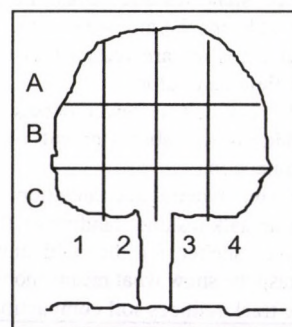

FIGURE 1

The position of sampling places in the leafy crown.

Evaluation: front- and back side of right and left side of every leaf, 3-3 visible - field per average

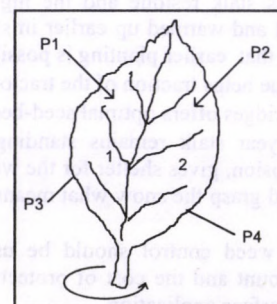
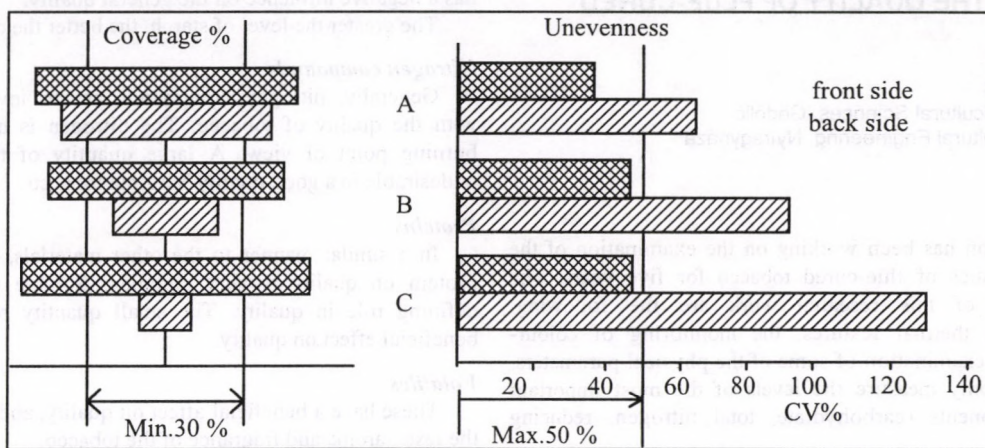

FIGURE 2

The surface of the examined leaf

Summary of the testing results



Work-parameters: – doses 1200 dm³/ha
 – advancing speed: 6,2 km/h
 – spray liquid pressure: 30 bar

FIGURE 3

Formation of coverage and unevenness in the case of the traditional spraying machine

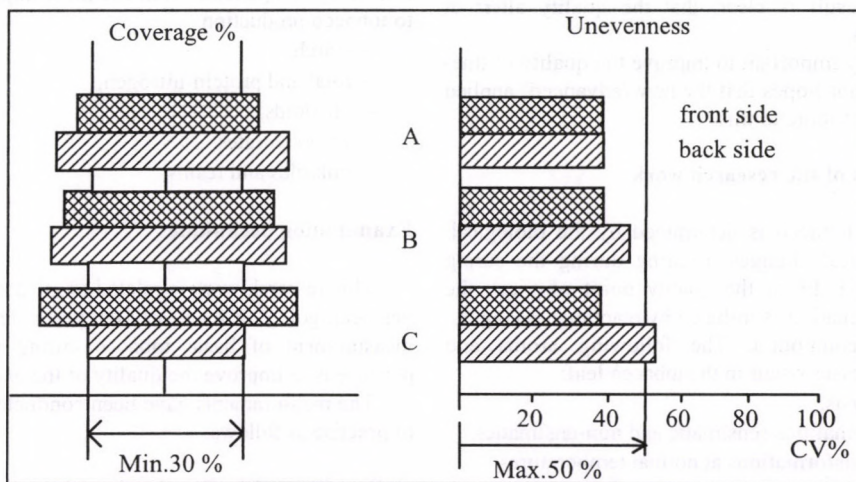

Work-parameters: – doses 400 dm³/ha
 – advancing speed: 4,1 km/h
 – spray liquid pressure: 1,5 bar

FIGURE 4

Formation of coverage and unevenness in the case of the electrostatic drop-fluid spraying machine

Conclusions

- MARTIGNANI electrostatic drop-fluid machines can be used in traditional fruit-gardens.
- Both the coverage and unevenness by the electrostatic spraying are favourable than the application of the traditional machines.
- The coverage conditions of the front and back side of leaves in the case of the electrostatic drop-fluid can be considered excellent.

- The stated advantages by the manufacturer of the electrostatic machine on the basis of the testings can be realised. Even in the case of various research conditions, there will not be any difference from the advantages stated in the brochure.

In summary, we recommend the application of MARTIGNANI kwh electrostatic drop-fluid spraying machines in the traditional fruit-gardens. Optimum research conditions also support the savings and advantages mentioned by the manufacturer.

TECHNOLOGICAL DEVELOPMENT FOR IMPROVING THE QUALITY OF FLUE-CURED TOBACCO

Dr. B. KERÉKES
University of Agricultural Sciences, Gödöllő
College of Agricultural Engineering, Nyíregyháza

Summary

Our institution has been working on the examination of the basic characteristics of flue-cured tobacco for five years. The main elements of this research work are the following: measurement of thermal features, the monitoring of colour-changes and the examination of some of the physical parameters. At present we only measure the levels of the most important chemical components (carbohydrate, total nitrogen, reducing sugar, nicotine).

The measurement of some of the chemical components has shown that there is a close relationship between the quality categories and the chemical characteristics of flue-cured tobacco. The amount of reducing sugar and total nitrogen varies considerably, depending on the curing schedule. The nicotine content does not change significantly. This means, that we are not able to influence the nicotine content by using this curing technology. Another result is clear, that the quality alters at different ripening levels.

In Hungary it is very important to improve the quality of flue-cured tobacco. The author hopes that the new (advanced) applied curing schedule can contribute to this.

The basic propositions of the research work

The quality of the tobacco is determined by the biological, biochemical and chemical changes occurring during the curing process (COLLINS, 1993). From the quality point of view, the most important transformation is initiated by reactions among the different groups of compound. The following aroma and fragrance forming processes occur in the tobacco leaf:

- enzymatic hydrolysis,
- oxidative transformations (enzymatic and non-enzymatic),
- non-enzymatic transformations at normal temperatures,
- non-enzymatic reactions at high temperatures.

Effect of the most important chemical components on the quality

Alkaloids

These contribute to the fragrance of the smoke and are closely related to the taste. In this way they contribute to producing quality. Generally, a lower alkaloid content indicates better quality, while the higher content indicates a stronger tobacco.

The main alkaloid in tobacco, nicotine, influences the sensitivity to the aroma. Scientists assume that a balance must be developed between the nicotine, nitrogen and sugar contents, in forming the quality of the smoke. The other important tobacco alkaloid, nor-nicotine, has an unambiguously negative effect on the quality (MANUEL, 1985).

Carbohydrates

Generally, these have a positive influence on quality, and have a role in the development of fragrance and aroma. Increasing the quantity of carbohydrate results in an improvement in quality, in conjunction with other characteristics. There needs to be a sufficient quantity of sugar to neutralise the acidity of the tobacco, but the too much sugar results in a „sharp” smoke (MENDEL, 1984).

Cellulose has a positive role in creating burning capacity, but has a negative influence on the general quality.

The greater the level of starch, the better the quality.

Nitrogen compounds

Generally, nitrogen compounds are in inverse correlation with the quality of tobacco. The nitrogen is undesirable from burning point of view. A large quantity of total nitrogen is undesirable in a good quality Virginia tobacco.

Proteins

In a similar manner to the other materials, the influence of protein on quality is very complex. Soluble proteins have a defining role in quality. The small quantity of protein has a beneficial effect on quality.

Volatiles

These have a beneficial affect on quality, and help to develop the taste, aroma and fragrance of the tobacco.

Waxes, resins

The combustion products of waxes affect the aroma of the smoke and the quality. In the experience of many specialists, the resins and their combustion products are positively related to the quality, but more precisely to the aroma and taste.

In the Hungarian research work we need to analyse the following components from the most important materials related to tobacco production:

- starch,
- total and protein-nitrogen,
- alkaloids,
- carbohydrates,
- volatiles and resins.

Examination techniques

This research work is related to my basic investigation, which has been going on for nearly ten years. The project is part of the measurement of basic tobacco curing parameters. The main purpose is to improve the quality of the end-product.

The measurements have been conducted in the laboratory and in practise as follows:

- a) Experimental curing in the laboratory wind-tunnel (model curing equipment) in the Agricultural College, with changes of practical technological parameters (KERÉKES, 1991).
- b) Determination of the water content and the main chemical components after curing and processing (fermentation). These tests have been carried out in the quality control laboratory of the local processing enterprise, using a conventional analytical technique, and the results have been compared with those from a quick infrared analysis.

The College has a complex instrument for testing agricultural materials. This is the Hungarian QA-262 INFRAPID-61 type quick analyser with its NIR (near infrared) developing system.

In addition to testing grain, this equipment is suitable for a fast and exact analysis of other agricultural products with greater water content (tobacco, fruit, vegetables). We can easily measure the amount of moisture and the main organic compounds, namely carbohydrate, total nitrogen, reducing sugar and nicotine. The measuring system can be used for a sequence testing of such materials for which it has been calibrated previously. For calibration, the given agricultural product has to be analysed in a conventional testing laboratory using at least fifty samples. Last year we completed this calibration work for different quality cured and processed (mechanical fermentation) tobacco.

The Test Results

Table 1
Comparison of the chemical components of different „mother leaves”

Quality category	Carbohydrate %	Reducing sugar %	Total nitrogen %	Nicotine %
AV	18.10	14.37	1.93	1.73
BV	17.81	11.26	2.58	1.55
ZV	9.09	8.08	2.54	1.57
B	6.46	4.08	2.61	1.67
C	4.93	3.55	2.41	1.52

Table 2
Comparison of the chemical components of different bottom leaves

Quality category	Carbohydrate %	Reducing sugar %	Total nitrogen %	Nicotine %
AV	12.33	9.44	2.28	1.33
BV	13.05	9.41	2.46	1.67
ZV	8.77	5.40	2.44	1.72
B	6.41	4.75	2.52	1.84
C	4.93	3.55	2.41	1.52

Table 3
Comparison of the chemical components of the processed tobacco

Quality category	Carbohydrate %	Reducing sugar %	Nicotine %
AV	16.63	12.34	2.33
BV	11.62	10.13	3.19
ZV	8.24	7.81	3.02
B	6.39	3.77	3.08
C	5.23	3.03	2.82

Evaluation of tables No. 1, 2, 3

The examinations of the chemical components has verified that there is a close correlation between the inspecting quality categories of the flue-cured tobacco and the levels of the internal components.

In Hungary, at present, the quality ranging is done by observing the colour of the tobacco leaves at the end of the curing (for example light A, light B, green, brown and category C).

From the enclosed tables it is evident, that the light A category tobacco – which is equivalent of the first class quality – has the largest content of carbohydrate and reducing sugar, and has the smallest total nitrogen. There is not a significant variation in the quantity of nicotine. We can conclude that the nicotine content cannot be influenced significantly by changing the curing schedule.

Secondly from these results it is clear that there is significant deviation between the qualities of the different ripening levels. The „mother leaves” in the middle of the stem give a better quality after curing. This is indicated by a larger quantity of carbohydrate and reducing sugar, especially in the first and second category (light A and B).

After processing (mechanical fermentation) of the flue-cured tobacco leaves, the chemical components do not change significantly, with the exception of the nicotine content, which can considerably increase.

Effects of curing schedules on some chemical components

My main aim has been to monitor the influence of different practical technological features on the important quality characteristics. Fulfilling this requirement, I have arranged to study altogether four curing cycles on two farms, applying a conventional and an advanced technology at the same time.

Four samples have been taken from each curing barn and transported to the local quality testing laboratory of the tobacco processing company, where the four most important internal components have been identified (carbohydrate, reducing sugar, total nitrogen, nicotine). In addition they have measured the moisture content.

The results of the analytical work are summarised in the table 4.

Table 4
Comparison of the component features of differently cured tobaccos

Curing method	Carbohydrate %	Reducing sugar %	Total nitrogen %	Nicotine %
Conventional	13.85	8.72	2.48	1.77
Advanced	17.96	12.38	2.10	1.46

It is now clear that measurement with the advanced (new) technology has resulted in more favourable levels of some important chemical components, that is, it has been produced a better quality at the end of the curing of Virginia type (H-11) tobacco. The above table indicates that, while using the advanced curing schedule, the content of carbohydrate was greater by 29%. The samples had a 41% greater level of reducing sugar and 18% less total nitrogen as well as a 21% lower nicotine content.

These results are unambiguous, indicating that these technological developments have an important role in the improvement of quality.

Final conclusions

The presented research work has tried to find relationships between the most important parameters which can influence the final quality of the flue-cured tobacco. Namely: how do the starting conditions of the practical curing parameters influence the quantity of the relevant chemical components appearing in the end-product? The evaluation model and the collection of information can provide useful basic data for tobacco growers and processing companies.

The results will contribute to the preparation of a new, more precise quality assurance system, and to the practical application of this quick analysis technique.

The discovery of these quantitative relationships between the curing technology and internal leaf characteristics is new both from a scientific and practical point of view.

The Agricultural College of Gödöllő University will incorporate these developments into the running training programmes and will establish cooperation with local tobacco farmers and the processing corporation.

References

- [1] COLLINS, W.K.- HAWKS, S.N.: (1993) Principles of flue-cured tobacco production. N.C. State University, USA.
- [2] KEREKES, B.: (1991) Technological and technical development of tobacco curing. Food Industry, No.2., p.64-69, Budapest.
- [3] MANUEL, L.: (1985) The quality of tobacco and its physical and chemical composition. Tobacco Journal International, p.485-486.
- [4] MENDEL, S.: (1984) Recent advances in tobacco research. Tobacco Science, No.3.

SOME EXPERIENCE WITH MEASURING THE SMELL EMISSION OF PIG HOUSES

Dr. A. MITYÓK - A. BÉRES
University of Agricultural Sciences, Gödöllő
College of Agricultural Engineering, Mezőtúr

Introduction

As it is well known the animal husbandry houses indicates their presence by odour. As the animal husbandry is unavoidable due to their role in the food production, the people accept the activity; in the most family houses of the villages and towns people keep some kind of animal. The properly kept few pigs and few tens of poultry can be well tolerated and is an everydayness phenomenon. The greatest repulsion to the animal keeping is generated by the smelly odour independently on that the objector person grows animal or not. The problem arises when the large scale farm model is used in small animal houses, because the necessary conditions of the transferred technology do not exist. The lacking conditions may be the lack of the manure deposition technicalness, of the afforestation made according to the human and animal hygiene aspects which defends against noise and smell and of the protective distance meeting the home regulations. The animal husbandry plants pollutes the environment in several ways and among the others by their odour from the smelly materials produced in operation.

In our department the odour effects of the animals of poultry and pig houses are also examined.

The research aim is to search relationships between the different animal husbandry technologies, keeping methods, the number of animals and the resulted odour for obtaining solution to reduce the odour emission.

Methods

The Hungarian standard regulation (MSZ 13-108-85) and the VDI directive (VDI 3881) describes an exact method of the odour measurement. The measuring principle and the measuring process has been described elsewhere, so here the results of the measurements are accounted for. In the measurements pure oxygen was used to dilute the odour material. The important persons of the measurements were selected in accordance with the MSZ 7304/10 standard regulations. The odour sample was taken from three levels (0.5 m, 1.0 m, and 1.5 m) of the animal house air. The repetition number was 5. In the choosing of measuring points the air flow generated by the ventilation was also taken into account. To find out the air motion cup anemometer measurements were carried out. The air speed in the stall measuring points did not exceed the 0.3 m/s value anywhere. The published measuring data are those measured in the height of the animal dwelling which were also the highest ones inside the animal houses. In addition the odour effect of the air leaving the ventilated animal houses of large scale farms. Those measuring values exceeded the values measured in 1.5 m height inside the animal house.

The primary aspect of choosing the buildings was that the most technology types and age groups be represented. So measurements were accomplished in the municipal area litter animal houses in the case of the daily and weekly cleaning of manure, in large scale stalls with no litter floor and cell keeping as well as in dropping-box stalls in the cases of daily and weekly manure removal.

The circumstances and results of the measurements

In large scale farms dropping-box stalls, cell piglet grower, porket stalls and fleshing buildings were examined.

In private farms one feeds no alimentary substances or premixes, but rather home made maize, wheat and barley middling as well as alfalfa flour mixed to pigwash is used. The manure cleaning is usually made in the forefront once in one to three days.

Odour emission values with different pig production technologies

Keeping method, applied technology	Odour unit measured (OU/m ³)
Small scale, litter, no concentrate feeding	14
Small scale, litter, pigwash feeding	21
Small scale, litter, four week manure	24
260 stock fattening, dry middling, liquid manure	70
260 stock fattening, wet fodder, liquid manure	100
260 stock grower, box keeping, 5 days manure	89
260 stock grower, box keeping, 2 days manure	51
Dropping-box stall, daily manure removal	45

Extremely high values were measured in the buildings where the floor was not cleaned regularly and the maintenance of the watering equipments and pipelines was inadequate.

In addition to the protective distance, the National Construction Regulation requires the consideration of the typical wind direction, too. The regulation does not distinct technologies and the size of animal population from the point view of protecting distance. The principles of allowing the location of animal houses are totally different in the VDI - the German directives. For establishing animal houses the „Directives” evaluates the different technologies by scores, taking into account the following aspects

- manure handling and locating,
- litter type,
- building construction,
- ventilation solution,
- difference between the inside and outside temperature in summer

In the way declared in the VDI directives the protective distance between the farm-house (or domiciliation) and the pig houses can be determined for various size animal populations and husbandry technologies.

In fig. 1 and 2 the relationship of the protective distance is shown for 5 and 100 pigs, respectively. The protective distance is the vertical axis in meter, the x axis is for the score of the building given by the VDI regulations, depending on the technology. (0 value means weak ventilation, wash-down manure removal, concentrate and premix content feeding; while 100 score value means well ventilated, well littered, daily manure removal, natural fodder feeding technology.) The z axis depicts the number of animals. One can clearly recognise, that the number of animals has much greater influence on the protective distance above ten animals the differences in the technologies are rather significant. The minimal protective distance mentioned above is at least 50 m, even in the case of a single pig and the most favourable technology.

Conclusions

- All the private farms use the technology described above, that is assumably why the measured odour emission values are lower than in large scale pig houses. (Of course the verification of the assumption needs further examinations.
- In the large lairages litter was not used anywhere, the animals were fed with fodder containing concentrate and protein, so that high smell effect was measurable.

- Extremely high values were measured in the buildings where the floor was not cleaned regularly and the maintenance of the watering equipments and pipelines was inadequate.
- After a proper home adaptation the method published in the VDI directives and shown in fig. 1 and 2 could help to solve the clash between the smaller or larger animal farm and the domiciliation which arises due to the odour emission.

References

[1] TÓTH, J.: Segédlet a Mathematica programcsomag használatához Windows környezetben. Kézirat, GATE Gödöllő, 1995.

(Supplement for using Mathematica program in Windows environment, in Hungarian)

Országos Építési Szabályzat, 1986. (Hungarian Building Construction Directives)

MSZ-13-108-85 „Kellemetlen szagok küszöbértékeinek meghatározása dinamikus olfaktométerrel” (Determination of the limit dilution value malodours by means of dynamic olfactometer)

MSz 7304/10-82 „A szaglóképesség vizsgálata” (Determining smelling ability)

VDI 3881 „Olfaktometrie - Geruchswellenbestimmung, Grundlagen” VDI-Verlag GmbH, Düsseldorf, 1986. p. 1-28.

VDI 3471 „Emissionsminderung Tierhaltung - Schweine” Berlin/Köln Beuth-Verlag 1986.

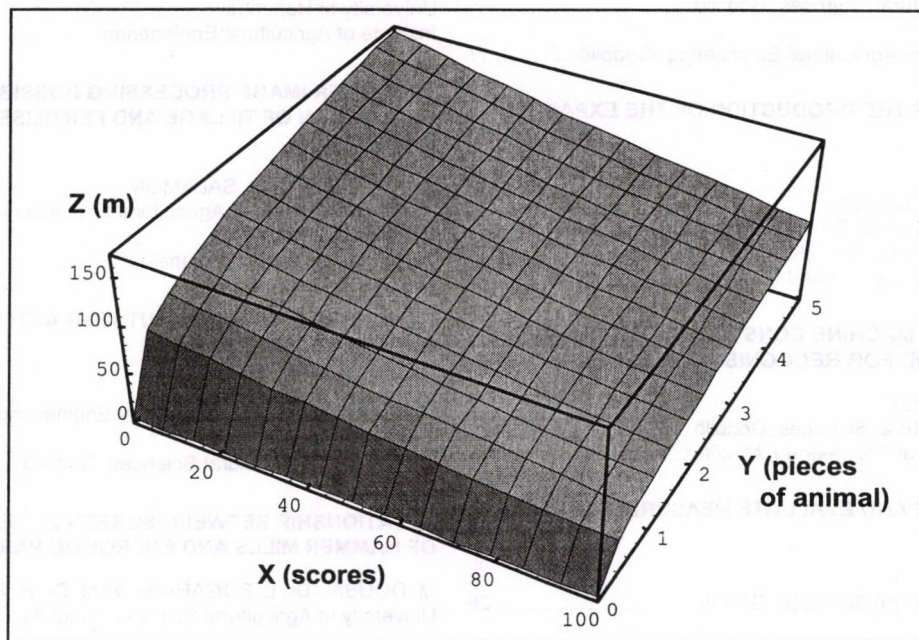

FIGURE 1

Protective distances according to the VDI directives as function of the applied husbandry technology and the number of animals (maximum five pigs)

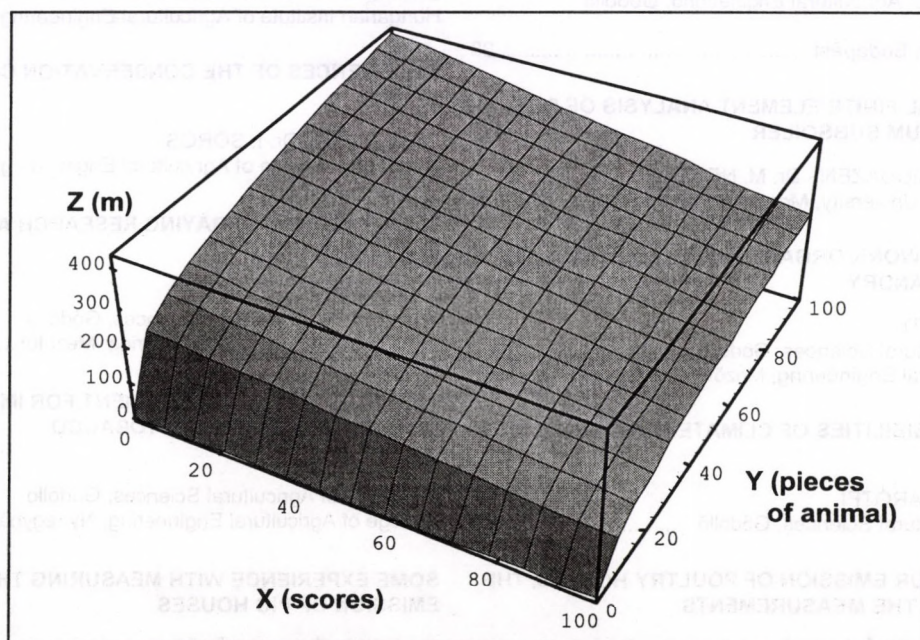

FIGURE 2

Protective distances according to the VDI directives as function of the applied husbandry technology and the number of animals (maximum one hundred pigs)

Contents of N° 9/1996.

ENERGETIC AND WORK QUALITY INVESTIGATION OF MAIZE STALK CHAFFING WITH ALONG-STALK DIGESTING

P. SZENDRŐ - L. BENSE - T. KISS
University of Agricultural Sciences, Gödöllő..... 12

ANALYSING CLEANING PARAMETERS OF MILKING DEVICES

Dr. L. TÓTH - Dr. A. TÚZ
University of Agricultural Sciences, Gödöllő
Dr. J. BAK
Hungarian Institute of Agricultural Engineering, Gödöllő 17

TEST RESULTS OF THE PRODUCTION OF THE EXPANDED MIXED FODDER

I. CSIZMADIA
Fodder Industry Ltd, Bábolna
Prof. Dr. J. CSERMELY D.Sc. - Dr. Z. BELLUS -
Dr. M. HERDOVICS - Gy. KOMKA
Hungarian Institute of Agricultural Engineering, Gödöllő 20

WEAK-POINTS OF MACHINE CONSTRUCTIONS AND A POSSIBLE METHOD FOR RECOGNISING THEM

P. VERMES - J. NAGY
University of Agricultural Sciences, Gödöllő
College of Agricultural Engineering, Mezőtúr 22

HOW TO COLLECT AND EVALUATE MEASURED DATA BY MATHEMATICA?

L. OROVA Dr.
University of Agricultural Sciences, Gödöllő..... 26

TEST RESULTS OF 150-200 KW POWER OUTPUT HEAVY UNIVERSAL TRACTORS

Dr. M. SZENTE
Hungarian Institute of Agricultural Engineering, Gödöllő
Dr. I.J. JÓRI
Technical University, Budapest..... 28

TWO-DIMENSIONAL FINITE ELEMENT ANALYSIS OF SOIL CUTTING BY MEDIUM SUBSOILER

ABDUL MOUNEM MOUAZEN - Dr. M. NEMÉNYI
Pannon Agricultural University, Mosonmagyaróvár 32

EXAMINATION OF WORK ORGANISATION QUESTIONS OF THE SHEEP HUSBANDRY

L. LENGYEL - I. TÓTH
University of Agricultural Sciences, Gödöllő
College of Agricultural Engineering, Mezőtúr 37

SIMULATION POSSIBILITIES OF CLIMATE CONDITIONS IN GREENHOUSES

M. SZABÓ - Dr. I. BARÓTFI
University of Agricultural Sciences, Gödöllő..... 39

MEASURING ODOUR EMISSION OF POULTRY HOUSES, THE EXPERIENCES OF THE MEASUREMENTS

A. BÉRES - Dr. A. MITYÓK
University of Agricultural Sciences, Gödöllő
College of Agricultural Engineering, Mezőtúr 42

ANALYSIS OF GRINDING'S BASIC ENERGETIC RELATIONSHIP (OTKA T 016124)

Dr. I. BÖLÖNI
Hungarian Institute of Agricultural Engineering, Gödöllő..... 44

AMMONIA EMISSIONS FROM COMPOSTING ANIMAL WASTES IN WINDROWS

K. CSEHI - J. BECK - T. JUNGBLUTH
University of Hohenheim,
Institute of Agricultural Engineering 46

COMPUTER IMAGE PROCESSING POSSIBILITIES IN THE EVALUATION OF TILLAGE AND FERTILISER SPREADER MACHINES

Dr. GY. DEMES - S. SALAMON
Hungarian Institute of Agricultural Engineering, Gödöllő
Dr. JÓRI J. ISTVÁN
Technical University, Budapest 49

EXPERIMENTS CARRIED OUT WITH ACTIVE CUTTING ELEMENT TILLAGE TOOL

Dr. L. FENYVESI
Hungarian Institute of Agricultural Engineering, Gödöllő
T. MEZEI
University of Agricultural Sciences, Gödöllő 52

RELATIONSHIP BETWEEN SCREEN SURFACE GEOMETRY OF HAMMER MILLS AND ENERGETIC PARAMETERS

M. DOUBA - Dr. L. FOGARASI - Prof. Dr. P. SEMBERY
University of Agricultural Sciences, Gödöllő 54

EVALUATING THE TECHNICAL PRODUCTION CAPACITY OF AGRICULTURE

Dr. J. HAJDÚ - Dr. Z. PESZEKI - Dr. I. TAKÁCS
Hungarian Institute of Agricultural Engineering, Gödöllő..... 56

EXPERIENCES OF THE CONSERVATION CORN PRODUCTION AT 1995.

Dr. S. SOÓS - Dr. I. SÖRÖS
Hungarian Institute of Agricultural Engineering, Gödöllő..... 58

ELEKTROSTATIC SPRAYING RESEARCH AT APPLE PLANTATIONS

I. KALMÁR - E. PETRÓ
University of Agricultural Sciences, Gödöllő
College of Agricultural Engineering, Mezőtúr 60

TECHNOLOGICAL DEVELOPMENT FOR IMPROVING THE QUALITY OF FLUE-CURED TOBACCO

Dr. B. KERÉKES
University of Agricultural Sciences, Gödöllő
College of Agricultural Engineering, Nyíregyháza 62

SOME EXPERIENCE WITH MEASURING THE SMELL EMISSION OF PIG HOUSES

Dr. A. MITYÓK - A. BÉRES
University of Agricultural Sciences, Gödöllő
College of Agricultural Engineering, Mezőtúr 64

Contents of the "Mezőgazdasági Technika" periodical of the year 1996

MEZŐGAZDASÁGI TECHNIKA

2100 GÖDÖLLŐ, TESSEDIK S.U.4.

Nº 1.

New Big Power MFWD tractors in the hungarian agriculture (M. Sente - I. Jóri J.).....	2
Once more from the Hannover DLG Fair (L. Tóth).....	7
Temporary anti-corrosion system (A. Horváth).....	15
Getting ideas from Farm Progress Shows (I. Husti).....	20
Economical aspect of the wood-chip production (L. Gockler).....	24

Nº 2.

The modernization program of the agriculture (S. Orosz).....	3
New machine in the spraying System (J. Huszár).....	12
Anti-corrosion paint-coating (A. Horváth).....	15
Energy saving! (F. Bohoczky).....	26
Buying-aid for the new agricultural machines (P. Körmendi).....	29

Nº 3.

Sustainable agricultural development (I. Láng).....	1
New tractors and tillage machines from USA (I. J. Jóri).....	4
Component renewing with powder metal spreading (L. Szabadi).....	15
Machinery and operation costs in 1996 (L. Gockler).....	23
Siómente Farmer Kft. (I. Kovács).....	28

Nº 4.

Pollutants effect on the operation of hydraulic systems (S. Czibere - J. Janik).....	2
Europe needs also the renewed hungarian seed dressers (J. Huszár).....	5
Features of the seedbed preparation machines and new ideas (S. Soós).....	6
Component renewing with powder metal spreading, Part II. (L. Szabadi).....	15
Tillage show in England (M. Birkás).....	20

Nº 5.

Testing of hydraulic energy-transformer with different oil temperature (L. Sassy - S. Török).....	2
Why should we use certified quick moisture tester? (R. Appel - J. Budai - J. Fükő).....	6
Increasing the hungarian combine harvester fleet with 200 pcs. new CLAAS one in this year (Gy. Pető).....	12
Technological improvement of potato storaging (J. Fűzy).....	26
Increasing the energy cost, pay more attention for energy consumption! (L. Gockler).....	28

Nº 6.

Anti-corrosion and abrasion methods for agricultural machine-parts (F. Szigeti - P. Bárczy).....	2
Pig fattening on deep litter handled by bioactive additives (G. Hörnig - G. Nitzsche, ATB Bornim; Gy. Mészáros - L. Mátyás).....	12
Rotary mower (Zs. Kelemen).....	15
John Deere combine harvesters in Hungary and rest of the world (I. Sörös).....	20
New directions for the mass produced goods transportation in the agriculture (J. Gyenge - J. Széles).....	26
Utilization of the implements stock in the agriculture (I. Wachtler - I. Magyary).....	28

Nº 7.

The result of the RS-8 forwarder functional test(B. Horváth)....	2
Deutz-Fahr harvester machines in Hungary (L. Szalai).....	6
Measuring of the odour effect of animal buildings (A. Béres - A. Mityók).....	12
The subsoilers (I. Jóri J.).....	15
The situation of machine management by data getting from FMMI's long-term waching farm (L. Gockler).....	20

Nº 8.

The main goal is the market (L. Lakos the Minister of Agriculture).....	1
Mechanization of the crop production by an integrator (A. Szaxon).....	3
Mechanization task for the modernization of agriculture (J. Hajdú).....	6
The situation of the fovestry machinery: today and tomorrow (B. Horváth).....	10

Nº 9.

Test results of the ERZ-1 forestry chopper (I. Czupy).....	2
The Vogel-Noot program is going on (I. Jóri J. - S. Soós - N. Koncos).....	12
Test results of the new combine - harvesters I. (I. Komlódi - Cs. Marton - I. Sörös).....	15
The machine utilization effects on the machinery costs (L. Gockler).....	22
The R+D work of milking-technics (L. Tóth - J. Bak).....	28

Nº 10.

Status determination of the homokinetic clutches (Zs. Tiba).....	2
Weeding technologies, developoing of row cultivators (M. Oláh).....	4
Plough competitions and machine show at Gödöllő (S. Soós).....	12
Test results of the new combine harvesters II. (I. Komlódi - Cs. Marton - I. Sörös).....	15
Traktors in the Word (J. Hajdú).....	20

Nº 11.

Experiance of reconstruction of the DSzP-32 type grain-dryer (Gy. Vargha).....	4
Hungarian test of the NEW HOLLAND TX 66 combine- harvester (Zs. Kelemen - I. Komlódi).....	12
Computer in the agriculture (J. Liskai).....	15
New order for implement qualification (G. Walz).....	20
Discussion of the energy management (L. Gockler).....	26

Nº 12.

Developing of a new milk-measuring device (L. Tóth - L. Fogarasi).....	2
Out of partour computerized feeding system (J. Bak - L. Kovács - L. Tóth).....	6
Exhibition of animal husbandry machines (I. Szabó - L. Tóth).....	12
Hammer mills (I. Bölöni).....	15
Fuel, grease, construction, environment (I. Valasek).....	20

Do you want to know more from
Hungarian Agriculture Machinery!

SENDMIS ORDER FROM TO:

The Hungarian Agricultural Machinery Journal
 H-2001 Gödöllő, Tessedik Sámuel u. 4.

ORDER FORM

I want order the Hungarian Agriculture Machinery Journal
 from day month 199.....

The subscription fee: 3240 HUF

Name:

Address:

Code, City:

Country:

Date: day month 199.....

.....
 signature

