

HUNGARIAN

AGRICULTURAL

ENGINEERING

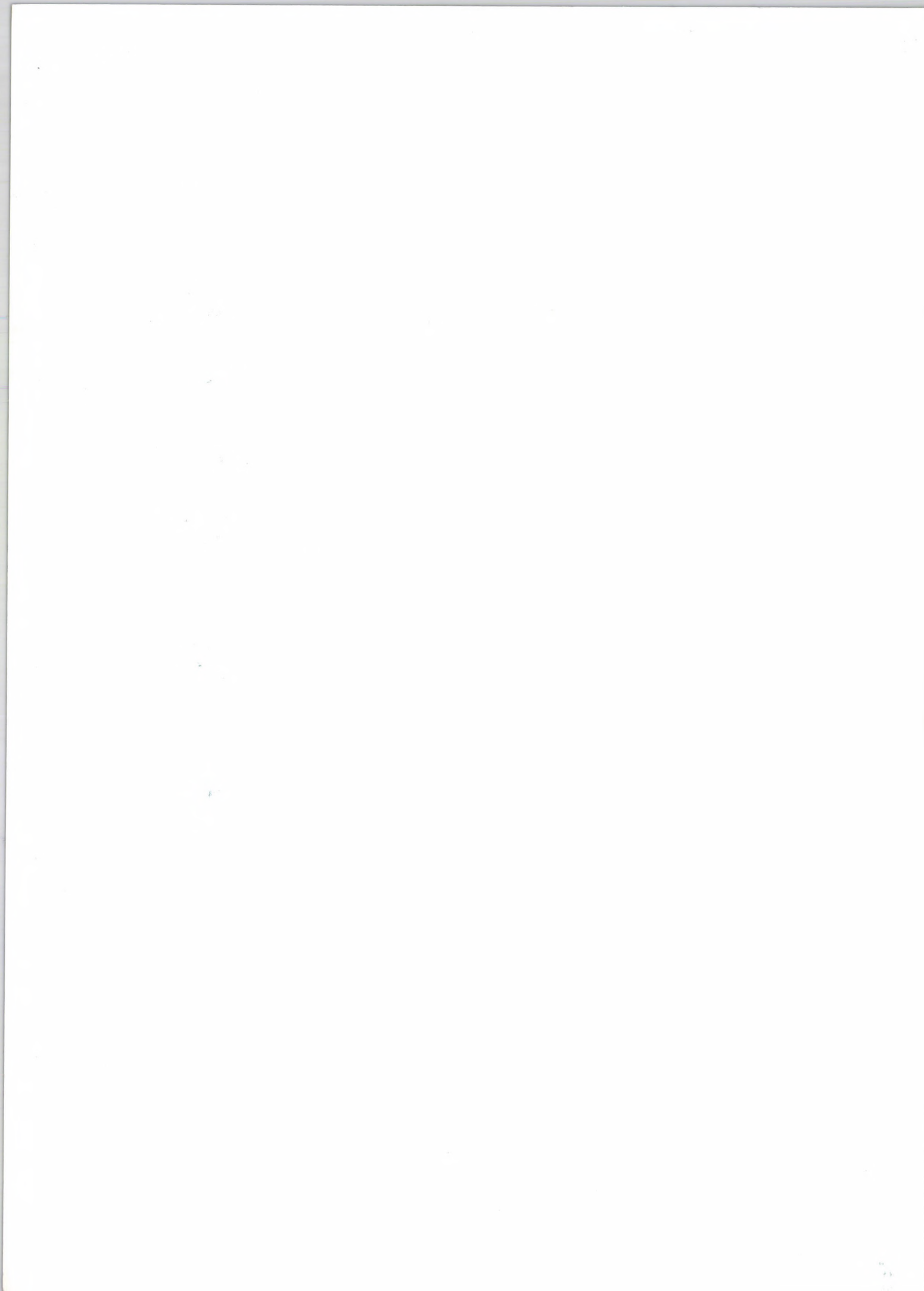





Hungarian Agricultural Engineering

N° 14/2001

Editor:
Prof. Dr. László TÓTH

Editorial Board:

Dr. Jenő CSERMELY
Dr. Imre DIMÉNY
Dr. István J. JÓRI
Dr. László FENYVESI
Dr. Péter SEMBERY
Dr. László TÓTH
Dr. János BEKE
Dr. Zdenek PASTOREK,
Czech. Republik
Dr. Jürgen ZASKE,
Deutschland
Dr. Vijaya G.S. RAGHAVAN,
Canada
Dr. Bart SONCK,
Belgium

PERIODICAL OF THE COMMITTEE OF
AGRICULTURAL ENGINEERING OF
THE
HUNGARIAN ACADEMY OF SCIENCES

Published by

Hungarian Institute of Agricultural Engineering
H-2100 Gödöllő, Tessedik S. u. 4.
Director: Dr. László FENYVESI



St. István University, Gödöllő
Faculty of Mechanical Engineering
H-2103 Gödöllő, Páter K. u. 1.
Dean: Dr. János BEKE



Gödöllő, December, 2001



Engineering Agricultural Engineering

№ 14/2001

EDITORIAL BOARD OF THE JOURNAL OF
AGRICULTURAL ENGINEERING
1998
INSTITUTE OF AGRICULTURAL ENGINEERING

Editorial Board

Institute of Agricultural Engineering
Faculty of Mechanical Engineering
Gdansk University of Technology
ul. Narutowicza 11/12, 80-233 Gdansk, Poland



ul. Narutowicza 11/12, 80-233 Gdansk, Poland
Faculty of Mechanical Engineering
Gdansk University of Technology
Prof. Dr. János BERKE



HU ISSN 0864-7410

Gdansk, December, 2001

- Dr. János BERKE
- Dr. Károly PASTORIK
- Czech Republic
- Dr. Jürgen ZASKE
- Germany
- Dr. Vijay S. RAOHAYAN
- India
- Dr. Hans SOMCK
- Belgium

PREFACE

The Agricultural Engineering Board of the Hungarian Academy of Sciences which supervises the development of this branch organises annually a conference at Gödöllő, which is the central place of the Hungarian agricultural scientific activity.

During the sessions, research scientist, developing engineers, experts of institutions engaged in agricultural engineering development strong in numbers the organizer, the hungarian universities and other higher grades of education, the research institutions: Hungarian Institute of Agricultural Engineering at Gödöllő, Faculty of Mechanical Engineering of the St. István University at Gödöllő and foreign guests give account of their results obtained in the research work and development of agricultural machinery.

This yearly English-Language publication the "Hungarian Agricultural Engineering", started at 1988, contains selected papers presented at the conference of 2001. We do hope that this publication will be found interesting to a big part of agricultural engineers.

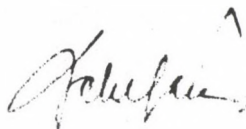

Dr. János Beke
Dean

Faculty of Mechanical Engineering
St. István University

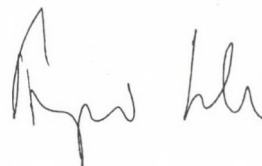

Dr. László Fenyvesi
Director

Hungarian Institute of Agricultural Engineering
Gödöllő

PREFACE

The following chapters are arranged in two parts. The first part, consisting of chapters I to VI, is devoted to the study of the general theory of the subject. The second part, consisting of chapters VII to X, is devoted to the study of the special theory of the subject. The first part is intended for the use of students who are beginning the study of the subject, and the second part is intended for the use of students who are already familiar with the general theory.

PART I.

ABSTRACT OF SELECTED PAPERS

ENERGETICAL RESEARCH OF STRAW CHOPPING

J. Bognár - P. Szendrő
Szent István University, Gödöllő

Straw is a vegetable by-product. It is chopped before utilization by a straw chopper installed to the combine-harvester, which operates in one round with grain harvesting. The structure of the chopped straw basically influences the effectiveness of next work phase. The aim of chopping is to produce a short piece, an equal size structure that is more suitable for processing pile of large fibrous structure. Chopping homogenizes and another requirement is also granted, notably that the surface of the fibres and stalks is increasing. By force induction the vegetable structure is shattered beyond the parting zone so not just the surface of the material is increasing but the stiffness of certain vegetable parts is decreasing. Designed for this purpose the features of rotary chopping equipments with free-turning knives equipped to horizontal rotation axis are the huge energy-need. It raises the price of technological work process. In consequence of the high chopping speed the incidence angle of knives is determined by the centrifugal force therefore the straw choppers work at cutting principle namely the energy-need increasing effect of scission stays unexploited.

The question arises that how the incidence angle of moving and fixed knives influences the chopping energy-need, does an optimum angle exist value besides the straw chopping is minimal?

OUTFLOW AND ARCHING PROPERTIES OF GRANULOUS MATTERS (SUBSTANCES)

Zs. Szüle - B. Csizmadia - P. Soós - E. Domonkos - I. Oldal
Szent István University, Gödöllő

In the application of the vertical grain-storage bin with gravitational discharge inserted in a technological system, the mass-flow is the most important technical parameter.

In the frame of research project OTKA (National Scientific Research Fund), number TO25365 among several mass-flow influencing factor, we examined the size and the cone angle of the outlet, the filling height and the effect of the internal friction coefficient in the case of wheat, corn, oat and granulated polythene grains.

EXPERIENCES IN A LARGE - SCALE DAIRY FARM APPLYING PRECISION ANIMAL KEEPING TECHNIQUE

L. Tóth
Szent István University, Gödöllő
J. Bak
Hungarian Institute of Agricultural Engineering

Summarising it generally, the data collected and processed with using the precision keeping technique are applicable for

- evaluating the milking method (the operators or the post schedule of shifts),
- analysing the effects of the changes in the setting of the teat cup detach units,
- analysing and showing the operating errors of the milking equipment,
- showing and selecting the cows being critical and needing special attention because of beginning udder inflammations (mastitis),
- eliminating the usual pre-milking probes (milking some drops by hand for visual examination before starting the machine milking process) because it is negligible when conductivity meters and analysers are applied (but it is correct only if the udders in the herds are clean).

OBTAINED RESULTS OF DIESEL ENGINE DEVELOPMENT SO FAR AND THEIR EFFECT ON POWER TRANSMISSION

A. Vas - Z. Lajber
Szent István University, Gödöllő

In the last few years a large-scale development has started and ripen in the diesel motor technique. These are the generalization of charging, alteration of characteristic of charger compressors, considerable increase of charging at lower engine speeds, in this connection the regulation of charging and generalization of fuel recooling. The direct injection and those combustion chamber and fuel flares which meet better the new requirements have become dominant.

Because of new improvements and in connection with this the numerous new technical solutions the outsider can register two phenomenon. At the 1-3 liter displacement volume category – first of all at diesel engines of cars – a considerable, approximately twice bigger engine rpm. has been developed. The other experience is from the area of commercial vehicles (tractors, vans) such as providing high margin of torque and raising of torque flexibility up to $k=1,5-1,7$.

Both of developments mainly have been ensured with changing of conditions of carbureting. As utilizing the benefits of advantageous relatively high air excess it had to reach the reduction of space of time demand of carbureting – combustion. The results could have been achieved with the improvement of internal and external conditions of carbureting and the application of new findings of electronics, control engineering.

COMPUTER AIDED PLANNING AND INFORMATION SYSTEM FOR PLANT PRODUCTION

J. Benkő - I. Husti
Szent István University, Gödöllő

In the last decades the method of production management went through a huge improvement. Nevertheless, not only the methods, but with the arrival of the computer era, the devices have also been changed. Computer aided production management integrates the planning and the production. Expenditures and costs became continuously controllable during the whole production period. The production means and materials can be used up with less costs and more security. An important advantage is that the management gets immediate and precise information. All these facts do improve the efficiency of the production management and the profitability of the company.

The endeavour for improving production management has certainly touched the agriculture as well. However, planning software available for the sector are far less than for the industry. Presumably, the reason is that in Western Europe the smaller farm sizes have not required this advanced management method and consequently they have not got to sphere of interests of the leading industrial software developers yet. As to the Hungarian software developers concerned, we guess, they have not realised the changes and demands yet. Experience shows that industrial applications can hardly be adapted to the agriculture because of the characteristics of agricultural production. It seems to be more reasonable to develop special software covering the agricultural characteristics. In this presentation we have the pleasure to give an account of our development experiment in this respect.

STATISTICAL INVESTIGATION OF PARTICLE SIZE DISTRIBUTION OF SOME GRAIN GRIST

E. Gyimes - R. Rajkó - A. Véha
University of Szeged

There are special roles of the geometrical sizes and specific surfaces determined by us in the mass and heat transfer. The determination of specific surface used in granulometrial tasks give satisfactory results to calculate drying and other heat and mass transfer processes, especially for grist. However, different calculation methods are needed for kernels, which are based on the approximated geometrical shape and its sizes. During the determination of the kernel sizes the widths depended on the varieties and the years.

Comparison of the particle size distributions of grist resulted that the Kolmogorov-Rényi's lognormal particle size distribution was the best fitted one in case of all wheat, corn and soybean. Of course this does not mean that the KR distribution would be the best in general, this conclusion refers only to the grinding experiments showed in this paper.

ANALYSING OF THE CORN DRYING PROCESS

J. Csermely - M. Herdovics
Hungarian Institute of Agricultural Engineering

During operation tests heat and material transport processes were determined and fairly accurate mathematical relationships were elaborated to describe the drying characteristics of corn as well as the changes of seed temperature and density.

DETERMINATION OF INNER VISCOSITY OF V-BELT BY BENDING TEST

L. Kátai - P. Szendrő - Gy. Vincze - I. Szabó
Szent István University, Gödöllő

In terms of temperature conditions the hysteresis loss during bending the V-belt to the sheave has significant importance. For measuring the temperature increasing originates from bending we made test equipment that generates an alternate motion. The above-mentioned temperature is measurable and to eliminate the effect of the slip the V-belt was fastened in the sheave. The test equipment can be applied for R&D because the different cross section constructions can be examined by a new standpoint.

During bending measurements with the help of the V-belt's viscoelastic model and with determining the $\Delta\varphi(t)$ central angle, which describes bending, the inner co-efficient of friction can be counted in thermal equilibrium status. The results can complete the drive design process and each cross section constructions become comparable with each other in terms of their bending behaviour.

UP-TO-DATE TECHNOLOGIES OF GRAIN STORAGE

Gy. Komka
Hungarian Institute of Agricultural Engineering

The international and national trends show the increase in rate and frequency of deterioration of stored feed raw material. One of the influencing parameters is the storing technology, because nowadays the storing capacity of Hungary mostly not adequate or not provides adequate conditions for safety storing.

Investigation of mechanization and feed quality can show the usability of the following technology:

- storage of cereals containing balanced moisture in controlled air-condition of barn,
- storage of cereals containing 16-18% moisture in barn equipped with automated ventilation system,

- storage of cereals containing 16-18% or balanced moisture treated with fluid preservatives

SLURRY HANDLING BY SOIL FILTRATION

L. Fenyvesi - L. Mátyás
Hungarian Institute of Agricultural Engineering

The object of the research was to determine filtering efficiency of the patented slurry handling process. (Reg.No: 2263/90. Patent owner: Dr. E. Geredy)

Tested filter beds are installed in pig farms of 500 and 1,200 sows. Sampling of check wells and laboratory analysis of raw slurry and filtered effluents was carried out by the laboratories of environmental protection of KÖTI-KÖFE & ATI-KÖFE.

According to the analysis and evaluation of the test results, as well as the operating conditions of the pig farms, it can be stated that the patented process which is based on simple an earthwork, has favourable characteristics. Drained filter beds can be loaded with a huge amount of slurry (6,000 - 17,000 m³/ha,year), and its surface demand is low (0.6-1.7 m²/m³,year). Filtering efficiency is very favourable as for OM; COD; BOD; NO₃⁻; NH₄⁺-N; PO₄³⁻-P in line: 85-95 %; 93-near 100 %; 36-78 %; 53-near 100 %; and 88-near 100 %.

On the basis of the test results slurry handling by soil filtration can be recommended to pig farms that have the required conditions, official authorizations, etc.

Filtering efficiency of soil filtration can be improved by mechanical pre-filter. Further examinations would be necessary to clarify some questions concerning enrichment of components in the upper layer of the filter beds.

RELATIONSHIP BETWEEN APPLIED TECHNOLOGY AND QUALITY OF STORED CEREALS

Gy. Komka
Hungarian Institute of Agricultural Engineering

The author investigated the effect of airing store technology in the aspect of changes in microbiological deterioration of cereals within OTKA project.

The number of mould in air-dried wheat and corn keeping the technological recommendations was considerable lower than authorized limit.

RELATIONSHIPS BETWEEN MECHANICAL AND NUTRITIONAL ASPECTS OF TUBULAR SYSTEM FOR FERMENTATION OF FEEDSTUFFS (OTKA T 030 031)

Z. Bellus
Hungarian Institute of Agricultural Engineering
J. Schmidt
University of West Hungary

Equipments developed for fermentation processes, which expanded in Western European and overseas countries appeared during the last years in Hungary for the challenge of agricultural production and feeding (bale-wrappers, one-pass baler and wrapper, plastic tubes). Application of these technologies is required for achieve appropriate quality. The tubular presservative system will be shown in this article, which is an up-to-date method for preservation and storage of stalky and other type of forages - based on pressurising system.

The method is suitable for fermentation of stalky and other forages, wet, dried, whole and ground grain, chopped whole plant material and other agricultural by-product (sugar-beet pulp, malt husks, sweet corn husks and tail corn) in form of whole seed, crushed or baled. This technology nowadays is only an additional system beside the conventional bunker silos, but it

is expectable to expand because of the reduced nutrient losses, better quality, higher nutrient content and better nutrient digestibility of the stored feedstuffs, moreover owing to its mobile and practical use. The mobile or stabile machines driven by tractor or own internal-combustion engine has large-scale power range, can solve feeding problem of large-scale farms with major livestock, indeed it is suitable for wage-enterprises. One of the prominent systems considering the quality and sold number of machines is the AG BAGGER apparatus produced by the BAG firm and distributed by the AG-BAG HUNGÁRIA Ltd. During the last years Italian (APIESSE, LUCLAR) and Czech (TAUROS) silo-press machines are also appeared in Hungary.

The Hungarian Institute of Agricultural Engineering and Department of Feeding Science (University of Western Hungary) investigated the AG BAGGER and APIESSE type silo-press among the above mentioned technologies in 2001 (supported by the OTKA). The author's aim was to investigate:

- how can this technology be adapted to the Hungarian conservative feed preservation system
- mechanical-technological parameters of the machines
- nutrient content and nutrient digestibility of feedstuffs produced by the mentioned technologies
- economical evaluation of the applied technologies

Summarising the author's objective was to establish and adapt a new preservation-storage system in to the Hungarian circumstances and determination of the mechanical-technological-nutritional relationships of this new technology.

COMPARISON OF CHAOTIC PARAMETERS OF PERIODIC SIGNALS

L. Baranyai

Szent István University, Faculty of Food Science, Budapest

The mathematical transformation of an object's outline data set - the polar coordinates of the perimeter pixels of the segmented object - is able to reveal chaos in the shape and create quantitative parameters to describe that chaos. Perimeter is divided into 360 parts - from 0° to 360° - and a map is generated on the basis of differences of radii. Maps show different textures and patterns for different object shapes. Because of the method of computation, these maps are diagonally symmetric. Three statistical parameters (entropy, homogeneity and uniformity of energy) are able to describe texture and successfully classify samples. Furthermore, the presented method is able to analyse any periodic signal. (OTKA F025730)

GRINDING-ENERGETICAL INVESTIGATION FOR DETERMINATION OF BREAD WHEAT'S KERNEL HARDNESS

A. Véha - E. Gyimes - E. Markovics
University of Szeged

In our research we introduce a new simple measuring method, which seems to be capable of objective and dimensionable determination of kernel hardness as an important energetic and qualitative fact.

We made measurements with the Perten's SKCS 4100 type device and with the PerCon 8100 type device operating on the basis of NIR principle, and with a method which measures grinding resistance during the grinding of wheat items.

For the object of the examination, we chose 17 Hungarian varieties of aestivum wheats with different quality.

We determined that all the three kernel hardness defining methods are capable of determining the kernel structure; the correlation between the measured hardness values is relatively close ($r = 0,663 - 0,847$).

Another remarkable result is that correlation between the results of the kernel hardness measuring methods is good, medium strong ($r = 0,66-0,85$). Hereby we can suggest that in spite of calibration difficulties, devices operated by NIR principles can be able to determine not only the quality, but the kernel hardness values, too.

PRESSURE AND VELOCITY FIELD MEASURING IN THE ENVIRONMENT OF IMPELLER OF AXIAL FLOW FAN

F. Szlivka

Szent István University, Gödöllő

J. Kópházi

Budapest University of Technology and Economics

We have report our researches about the determination of developing flow pattern in the axial flow fan impeller promoted by OTKA (T 026516) in our researches about the calculation of flow pattern [1]. As a further development of this research topic we review that measuring method which is based on pressure measuring and has been developed for the measuring of evolving velocity and pressure field in the environment of impeller of axial fan. Compared this improved measuring method to the measurements that have been done with the formerly used Laser Doppler Anemometer (LDA) we can say that the results of this new method are very well applicable at the measuring of velocity field in the environment of impeller in addition to this is right for to determine the pressure field. In this way we have determined the spatial distribution of static pressure directly behind the impeller as well as the spatial distribution and direction of total pressure in a fixed system to the blade channel. Using of this method you can record the pressure distribution not only one but even all of the blade channels. Therefore we had an opportunity to map locally the waste sources of fluid mechanics processes in the impeller: to determine the pressure loss and the hydraulic efficiency at each points what we can't do if we only know the velocity field.

DETERMINATION OF CRITICAL CONDITION OF CHOPPED STRAW MASSES WITH IMPEDANCE MEASURING

L. Bense - P. Szendrő - Gy. Vincze

Szent István University, Gödöllő

The loading for the evolution of anaerob conditions can be determined with impedance measurement. During the elaboration of the method our hypothesis was that changing of the physical features follows the structure change of the mass. The stabilization of some physical feature shows the formation of the stable internal structure. In our opinion the examination of non-continuous changing of specific resistance is suitable for this purpose. We determined that the impedance of chopped straw silo-maize mass plotted against moisture content and density with constant capacitor coating distance but it does not change measurably during the sample relaxation. The capacitive reactance of the mass is negligibly small so we can substitute the measured impedance for ohmic resistance. We introduced the $\frac{R}{\sigma\rho}$ specific resistance that shows a clear break point

plotted against density and loading. Because the mass elements do not suffer further damage on this loading we reckon that the reason of the changing is the formation of the maximum joint surface of the fragments, so the evolution of the anaerob condition.

MODELLING OF FRUIT-PRODUCING FARMS WITH SPECIAL REGARD TO CAPITAL APPRAISAL OF INVESTMENT

Katalin Takács-György
Szent István University, Gödöllő

Establishment of plantation sector is the most hazardous investment in agriculture. The associated high risk derives both from the long time span and the high specific investment costs. The fruit-producing sector was one of the losers of the economical and social changes during the last 10 years. At the same time the participant of the sector have to meet the requirements of ever changing consuming habits. Considering the high investment costs of fruit-growing and considerable current asset lockup of production-financing it is necessary to model examination of investment return in the sector. The aim of the study is to examine the return of capital investment increased by additional costs that incur during economic decisions of establishing plantations. The model devised for this purpose determines investment return of apple production. Furthermore, it helps in determining a minimal selling price to be achieved for a full return of the invested capital with regard to pre-set costs and enterprise size. According to the results it can be concluded for instance that the investment return of studied plantations can not be secured from the state procurement prices in the year 2000. The price should exceed 30 Ft/kg to meet this criterion.

INVESTIGATION OF THE BINDING AND DIFFUSION ENERGY OF WATER IN YEAST (*SACCHAROMYCES CEREVISIAE*) (OTKA T 032666)

M. Neményi
University of West Hungary
L. Berecz
Process Engineering of Agricultural Products, Research Group of the Hungarian Academy of Sciences

There are many reports in the literature dealing with the binding energetics of water in foodstuff, such as yeast. The methods used to calculate the binding energy are based on the analysis of sorption isotherms and application of the Clausius-Clapeyron equation. However, the reported values agree slightly. As a new method, in this study the energy balance of the drying was established by means of moist air state equations, then the energy needed for binding and diffusion of water was calculated in dynamic conditions. The experiments were carried out in a PC-controlled drying tunnel. The temperature of inlet air was 45 °C and the air velocity was 0.3 ms⁻¹. The layer thickness was chosen as 1.9, 2.3, 2.6, 4.1 and 4.9 mm.

THE INFLUENCE OF ROOT SYSTEM ON SOIL RESISTANCE

B. Horváth - T. Major
University of West Hungary, Sopron

Establishment of the computer soil – model that is really difficult in modelling soil – machine correlation. Modelling the machinery is relatively simple knowing the structural parameters and the material characteristics. The description of the mechanical properties of the soil and the description of its regularity is really a difficult job since its complicated structural construction and its inhomogeneity. An additional difficulty may occur in our forests as far as stumped and rooted lands are concerned. The occurrence of roots may increase the solidification of the soil. (The increment even can be 50-70 %). This thesis was designed to find the proper answer how soil resistance changes -influenced by the root system in the correlation with tree species, diameter and distance from the tree.

FIXED BED DRYING CHARACTERISTICS OF YEAST (*SACCHAROMYCES CEREVISIAE*) IN DIFFERENT LAYER THICKNESS (OTKA T 032666)

L. BEREZC
Process Engineering of Agricultural Products, Research Group of the Hungarian Academy of Sciences
M. NEMÉNYI
University of West-Hungary

Drying characteristics of beer yeast were investigated in a convective drying tunnel in order to establish the function between the drying time and moisture content. The drying curve was described as

$$\frac{X - X_e}{X_0 - X_e} = \exp(-K\tau)$$

where: X moisture content on dry basis, K drying constant, τ time. Indices 0 and e designate the initial and equilibrium states, respectively.

Inlet air temperature was chosen as 40 °C, 45 °C and 50 °C as we determined from our previous investigations [1, 2]. The layer thicknesses were 1 mm, 2.1 mm (only on 45°C and 50°C), 3 mm and 5 mm, inlet air velocities were 0.5, 1.3 and 2 ms⁻¹. The K drying constant was determined as a function of the temperature and the layer thickness. The equation obtained contributes to the planning of yeast drying processes.

APPLICATION OF ALTERNATING - CURRENT HYDRAULICS TO DEVELOP STUPLIFTING MACHINERY

I. Czupy - Dr. B. Béla
University of West Hungary, Sopron
J. Lukács
Mechanical Engineering of Miskolc University

Stumplifting technology requires tremendous amount of strength (several thousand Newton) depending on several factors like soil compactness, stump-diameter, tree species. According to our proposal the suitable strength and moment required to remove stumps can be significantly reduced if prior to application of any stumplifting technology compactness of the stump referring to its environment is to be reduced. One of the possible ways to implement this task is to vibrate the soil in order to loose soil – root correlation. The proper frequency of vibration seems to be the very case when the vibration frequency is equal to the stump – earth dominant own-frequency. Theoretically the equipment of vibration could be established on several techniques. But if practical approach occurs always the most applicable and the most efficient method should be selected. Since relatively enormous vibration performance and wide domain of frequency is required that is why to loose stump compactness application of technical elements of altering – current hydraulics is suitable. In the process of implementation of this equipment possible way of anchoring of phase-piston is to be guaranteed. We would be very pleased to launch very efficient, practical and applicable equipment, which can be easily attached to the power engine.

EXAMINATION OF FOREST STREAM SEDIMENT CHARACTERISTICS WITH PRINCIPAL COMPONENT ANALYSIS

Z. Gribovszki
University of West Hungary, Sopron

In Hungary we have a fairly few information about erosion and sediment transport processes and relationship of these processes with environmental parameters. The following examination try to compensate this lack on the basis of sedimentation measuring in two neighbouring catchments (Farkas (Wolf) Valley and Vadkan (Boar) Valley) of Sopron Mountain.

Beside sediment quantity, sediment quality parameters are also available to trace of environmental changing caused natural and artificial impacts. Some kinds of disturbing effects are manifested better in changing of sediment quality parameters than changing of sediment discharge. The exploration of so many variables containing (sediment quantity and quality parameters) connection system is more expressive with complex statistical analysis. Under this work, relationships between sediment characteristics and environmental parameters have examined with principal component analysis.

FOREST ROAD PLANNING WITH THE SOFTWARE ERDÚTTERV

J. Péterfalvi - G. Markó
University of West Hungary, Sopron

It is impossible nowadays to make a forest road plan without aid of computer program. The main problem is not to find adequate hardware possibilities but to find the most suitable computer program that takes demands of forest road planning into consideration. The Department of Forest Opening Up and Forest Hydrology in West-Hungarian University has continually developed forest road planning programs from the 1980-s. Programs of early period had aided the planning process very much but handling them was difficult. The hot result of development is the 'Erdúttterv' computer aided designer program. This is a user-friendly program with graphical user face.

PLANNING OF OPENING UP NETWORK WITH DIGITERRA MAP GEOINFORMATIK SOFTWARE

M. Kosztka - G. Markó - J. Péterfalvi
University of West Hungary, Sopron

Forest opening up networks, which is serviced Semi-natural multi-functional forestry, have to plan like a land opening up system because of several opening up demand are at the same time on the examined territory. During planning of the land opening up networks we try to gather all network system influencing demands and impacts and we try to plan network variations which exhausting these demands. The instantaneous best solution among variations can be chosen only throughout wide-ranging analysis. This means, that during planning and decision phases we need handle lot of geographic data, in which GIS programs help us. We have tried to elaborate planning of Börzsöny by aid of DIGITERRA MAP GIS software of DIGITERRA Bt. We established on the basis of this work, that elaborated network planning system by us and DIGITERRA MAP GIS software are suitable for planning of land opening up networks.

TRIBOTESTING OF ENGINEERING POLYMERS

L. Zsidai - G. Kalácska
Szent István University, Gödöllő
P. De Baets
University of Gent, Belgium
M. Kozma
Budapest University of Technology and Economics

The engineering applications of plastics are strongly connected to the different tribological systems, where the machine parts are subjected to friction and wear processes. The design for lifetime of metals in tribological systems has not solved yet, even less known for engineering plastics. The test evaluation and concluding process are rather difficult taking the specific behaviour and features of the polymers into consideration. Due to this point we have been carrying out a wide-ranged tribo-testing with large-scale and small-scale plastic specimens. Based on the

obtained results seeking the correlation between the two main systems we try to conclude more general principles. This paper gives a short view about the small-scale experiments.

We have done measurements with plastics like POM-H; PETP/PTFE; POLYAMIDES. This was a linear friction-sliding measurement of cylindrical specimens against a metal plate. Measurement was made at 100N and 200N load and in two surfaces categories.

OPTICAL CHARACTERISTICS OF TRANSPARENT INSULATION MATERIALS

M. Szűcs - I. Farkas
Szent István University, Gödöllő

In this paper the optical characteristics of transparent insulation (TI) materials are studied. During the analysis various geometric structures and materials were taken into account. The light transmission measurements were carried out by the use of Ulbricht-ball and with the help of a laboratory measuring unit. The light transmission factors for different TI materials and structures were determined at a different incident angle of light radiation. Sensitivity of light transmission on the thickness was also determined.

PROCESS-ATTITUDE ANALYSIS OF SOIL TILLAGE SYSTEMS

M. Birkás
Szent István University, Gödöllő
L. Csík
MEZŐGÉP Ltd., Szolnok

The process a set of interrelated resources and regulated activities, which transforms inputs into outputs. Soil tillage in the quality assurance respect can be considered as a process, and is to be evaluated by process-orientation. Soil tillage systems can also be accepted by a linear process series. A multi-traffic soil tillage system can consist of nine process elements. If the quality capability of the individual process elements is below 100%, and the faults of the elements are not been improved during the process, the quality capability of the process series has also got a lower level. According to the national tillage experience were determine the main phases of the tillage system, which affect on the quality of the next phases and on the other ones as well. It was stated, that combination of the process elements and development of those quality capabilities are to improve the capability of the output (that is soil condition suitability to sow). Combination of the elements results in a decrease of the tillage faults (e.g. a multi-traffic system vs. a till-plant system). In this study the advantages of the process attitude adoption are also summarised. This paper present results of research programs supported by OTKA 34.274 and INCO COPERNICUS CA ERB IC15.

MEASURING CUSTOMER SATISFACTION AS AN ELEMENT OF QUALITY EVALUATION

P. Vermes - S. Szűcs
Tessedik Sámuel College Mezőtúr, Faculty of Agriculture

The satisfaction of customers is an important index number of the power of the organization. To get information related to customers' satisfaction is not easy. The problems are caused by a "slit" at the joining points of customers and organization that cause a loss and distortion of information. The poster paper shows the procedures that organizations apply in the area of collecting and processing customer information.

1. Energy of 1.5 GJ/ton
2. Fuel for a 1000 kW boiler

The energy content of straw is a function of its chemical composition. The main components are cellulose, hemicellulose, lignin, and ash. The energy content is determined by the amount of these components. The energy content of straw is approximately 1.5 GJ/ton. This energy can be used for various purposes, such as power generation, heating, and industrial processes.

PART II.

SELECTED SCIENTIFIC PAPERS

The energy content of straw is a function of its chemical composition. The main components are cellulose, hemicellulose, lignin, and ash. The energy content is determined by the amount of these components. The energy content of straw is approximately 1.5 GJ/ton. This energy can be used for various purposes, such as power generation, heating, and industrial processes.

The energy content of straw is a function of its chemical composition. The main components are cellulose, hemicellulose, lignin, and ash. The energy content is determined by the amount of these components. The energy content of straw is approximately 1.5 GJ/ton. This energy can be used for various purposes, such as power generation, heating, and industrial processes.

The energy content of straw is a function of its chemical composition. The main components are cellulose, hemicellulose, lignin, and ash. The energy content is determined by the amount of these components. The energy content of straw is approximately 1.5 GJ/ton. This energy can be used for various purposes, such as power generation, heating, and industrial processes.

The energy content of straw is a function of its chemical composition. The main components are cellulose, hemicellulose, lignin, and ash. The energy content is determined by the amount of these components. The energy content of straw is approximately 1.5 GJ/ton. This energy can be used for various purposes, such as power generation, heating, and industrial processes.

ENERGETICAL RESEARCH OF STRAW CHOPPING

J. Bognár - Dr. P. Szendrő
Szent István University, Gödöllő

Straw is a vegetable by-product. It is chopped before utilization by a straw chopper installed to the combine-harvester, which operates in one round with grain harvesting. The structure of the chopped straw basically influences the effectiveness of next work phase. The aim of chopping is to produce a short piece, an equal size structure that is more suitable for processing pile of large fibrous structure. Chopping homogenizes and another requirement is also granted, notably that the surface of the fibres and stalks is increasing. By force induction the vegetable structure is shattered beyond the parting zone so not just the surface of the material is increasing but the stiffness of certain vegetable parts is decreasing. Designed for this purpose the features of rotary chopping equipments with free-turning knives equipped to horizontal rotation axis are the huge energy-need. It raises the price of technological work process. In consequence of the high chopping speed the incidence angle of knives is determined by the centrifugal force therefore the straw choppers work at cutting principle namely the energy-need increasing effect of scission stays unexploited.

The question arises that how the incidence angle of moving and fixed knives influences the chopping energy-need, does an optimum angle exist value besides the straw chopping is minimal?

1. Operation features of straw choppers

The straw choppers installed to combine-harvesters work with passive counter knives. The distance between the moving and fixed knives is 5...20 mm. In the case of such cutting the big peripheral speed knife causes big local deformation in the case of little cutting force, too. The knife penetrates to the material and because of the increasing pressing and pulling stress, the fibre is cracked in the place of the biggest stress, so at the edgewise of the knife. If the distance between the chopping and counter knife is big, the fibrous material is cracked while exceeding not only shearing but tensile strength (Figure 1).

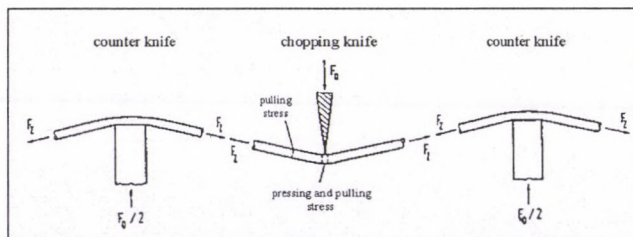

Figure 1 Forces affecting the material and stresses inside of it

During cutting process of a straw fibre we can distinguish two phases:

- the first is the preliminary compression of the material to the pressure when the hollowed stalk is collapsed,
- during the second phase the material under the edge is ran, the edge penetrates and cuts through the material.

The above-mentioned two phases are well noticeable on cutting diagrams (Diagram 1).

There is a difference between cutting (cutting in normal direction) and scission (pulling or slipping cutting). In the case of scission the cutting speed (v_s) has one component (v_t) in edgeways (Figure 2), so the cutting force-need is smaller, which can be traced back to decreasing of knife edge-angle (β)

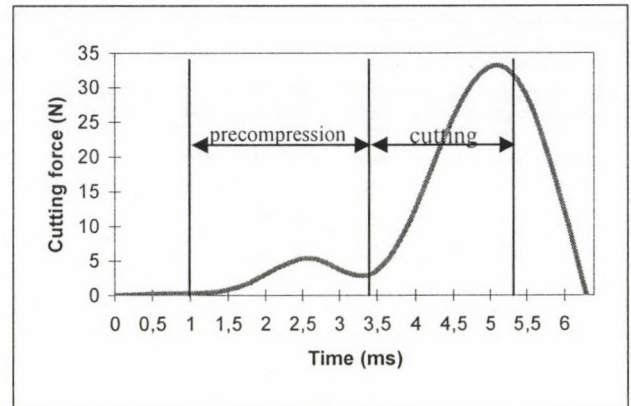

Diagram 1 Cutting force running in time
(Kisvárdá 63 rye; $v=1,2$ m/s; $w=34\%$; $a=10$ mm; incidence angle of moving and fixed knives is 0°)

and the "finesaw" affect originates from the micro-and macroscopic roughness of the edge (Figure 3). The condition of the scission is that the incidence angle of the knife must be bigger than the amounts of the two frictional half-cone angles between the knives (cutting and counter knife) and the material. In practice it means that the material slips between the knife-edges.

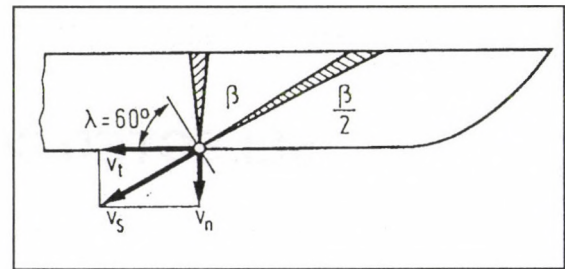

Figure 2 Decreasing of speed conditions and knife edge-angle while scissoring

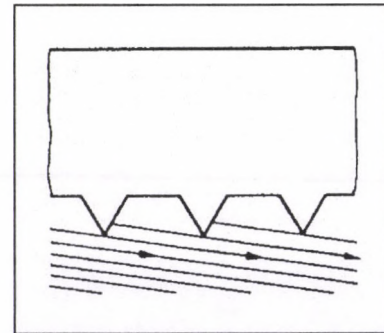

Figure 3 "Finesaw" affect originates from macroscopic surface roughness of the knife edge while scissoring

The tensile of the cutting is the quotient of v_t and v_n speed components:

$$\operatorname{tg} \lambda = \frac{v_t}{v_n} \quad (1)$$

2. Testing cutting conditions

Figure 4 demonstrates simplifying and approaching the straw before chopping and the forces affect on it. Suppose that the cross-section of the straw fibre is a perfect annulus shape.

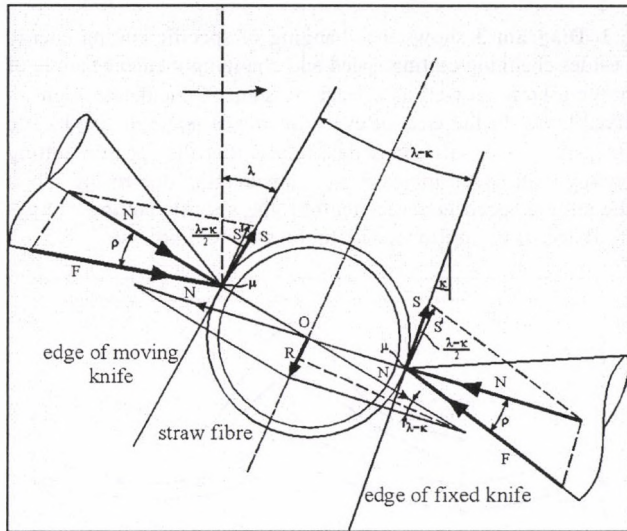

Figure 4 Determining borderline case of the scission

The moving knife is doing a circular motion with λ setting angle around the axis of the straw chopper and the fixed knife supports the straw fibre with κ setting angle. We measure the force conditions considering forces affect on the elementary fibre on condition that the value of friction co-efficient on both cutting edge is equivalent. We can determine the limit value of the incidence angle of knives from the condition that in the borderline case of scission the material does not a bit slip on the cutting edges. In borderline case the influence line of F force is just on the generatrix of the frictional cone and during the scission this line is outside of that. The resultant force affecting on the straw fibre can be interpreted in the bisector of the included angle by the two cutting edges.

On the basis of the Figure the condition of the equilibrium is the following:

$$2S' \leq R, \quad (2)$$

where:

$$S' = N \cdot \mu \cdot \cos \frac{\lambda - \kappa}{2}, \quad (3)$$

from this

$$R = 2N \cdot \sin \frac{\lambda - \kappa}{2}. \quad (4)$$

Substituting (3) and (4) relations for (2) we can determine that

$$2N \cdot \mu \cdot \cos \frac{\lambda - \kappa}{2} \leq 2N \cdot \sin \frac{\lambda - \kappa}{2}. \quad (5)$$

Simplifying:

$$\mu \leq \operatorname{tg} \frac{\lambda - \kappa}{2}, \quad (6)$$

namely:

$$\operatorname{tg} \rho \leq \operatorname{tg} \frac{\lambda - \kappa}{2}. \quad (7)$$

We can see from this relation that the straw fibre slips on the edge of knives only when the included angle of moving and fixed knives is bigger than the double of the frictional half-cone angle:

$$2\rho \leq \lambda - \kappa. \quad (8)$$

Markings in the relation:

λ : setting angle of the moving knife,

κ : setting angle of the fixed knife,

F: resultant cutting force affects on the straw fibre,

N: the component at right angles to knife-edge of resultant cutting force affects on the straw fibre,

S: the knife-edgewise component of resultant cutting force affects on the straw fibre, frictional force

S': the component of frictional force taking a course R,

R: F resultant force of the point of contact,

μ : friction co-efficient,

ρ : the angle of frictional half-cone angle.

3. Calculation of cutting energy-needs

During the measurements we measured the cutting force (F) of fixed knife and the average peripheral speed (v) of moving knife plotted against time (t). Integrated numerically the area under the cutting force-cutting path diagram, the cutting energy is:

$$E = \sum_{i=1}^n F_i \cdot (s_{i+1} - s_i) = \sum_{i=1}^n F_i \cdot (t_{i+1} - t_i) \cdot v \quad i=1 \dots n \quad (9)$$

where:

E: cutting energy (J),

F: cutting force (N),

s: cutting path (m),

t: cutting time (s),

v: average cutting speed (m/s) and

n: number of measuring datas.

Because diameter and thickness of the fibre is different, we measured these after every cut then we counted the specific cutting energy assuming annulus cross-section:

$$E_s = \frac{E}{A}, \quad (10)$$

$$A = \frac{(D^2 - d^2)\pi}{4}. \quad (11)$$

where:

E_s : specific cutting energy (J/mm²),

A: cross-section of the stalk (mm²),

D: external diameter of the shrank (mm) and

d: internal diameter of the shrank (mm).

4. Measurement process and measurement parameters

In order to laboratory tests we planned a function model and designed an adequate measuring method. The function model is high-speed swing equipment, which is suitable for the changing of constructional (status of the straw compared with moving knife, sharpness of the knives, distance between counter and moving knife, method of fibre-gripping), operational (speed of cutting knife, number of chopped fibres) and vegetable (humidity, ripeness status, crop type) parameters. On the other hand besides 7...12 m/s cutting speed it makes cutting force-need measurable.

Measurement settings:

- average cutting speed (v) 1.2 m/s, 3.4 m/s, 7.1 m/s, 11.6 m/s;
- distance between fixed and moving knife (a) 6 mm, 10 mm, 15 mm, 25 mm;

- incidence angle of fixed knife in 0° - -30°, 10° steps;

- incidence angle of moving knife in -30° - +30°, 10° steps;

- humidity of the straw (w) 34%;

- straight-edge cutting knife (Claas series straw chopper);

- a fibre in different type.

5. Measuring results

5.1. **Diagram 1** shows the cutting force process in time. On the Diagram two phases can be separated: during the first phase, the pre-compression the deformation, collapse and compression of tubular structure by the affect of increasing cutting force is well noticeable. The second phase is the effective cutting when the knife cuts and separates the stalk then in the running out phase of force curve passes and pushes out the chopped straw.

In the 0° incidence angle of fixed and moving knives comparing force-curve process in time we can determine that the maximum cutting force occurs in the case of cutting (so the incidence angle of moving knife is also 0°) and with the increasing of incidence angle of moving knife the maximum cutting force is decreasing.

In the case of pulling cutting it is determined that the maximum of cutting force is smaller than in the case of regular cutting as well as force-maximum is built slower so the pre-compression-separation-time-proportion is changed and the separation time will be longer.

5.2. **Diagram 2** shows the changing of specific cutting energy plotted against the incidence angle of fixed and moving knife besides 11,6 m/s cutting speed.

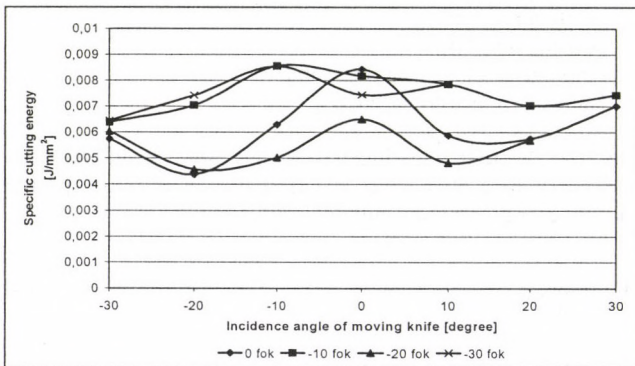

Diagram 2 Specific cutting energy plotted against the incidence angle of fixed and moving knife
(Kisvárdá 63 rye; $w=34\%$; $a=10$ mm; $v=11,6$ m/s)

Watching the curve belonging to the 0° incidence angle of fixed knife it can be determined that cutting has the biggest specific energy-need. Increasing incidence angle of moving knife, the cutting energy is decreasing, it is minimal in the 15-20° angle range then it is rising again. The possible explanation of the phenomenon is that in the case of incidence angle bigger than 20° the friction co-efficient between the straw and the knife-edge is smaller than the value counted from the condition of scission so the stalk slips on the knife-edges that yields increasing cutting energy-need.

It is striking on the Diagram that in the case of -20° incidence angle of fixed knife the specific energy-need of cutting is considerably smaller than in the case of other measurement settings. It can also be traced back to the above-mentioned phenomenon.

5.3. **Diagram 3** shows the changing of specific cutting energy besides changing cutting speed and changing incidence angle of moving knife as well as certain constant 0° incidence angle of fixed knife. In the case of every incidence angle of fixed knife (0°; -10°; -20°; -30°) it is determined that the specific cutting energy with speed increasing is considerably decreasing. So if the cutting speed increases tenfold, the specific cutting energy-need decreases approximately to the second, third part.

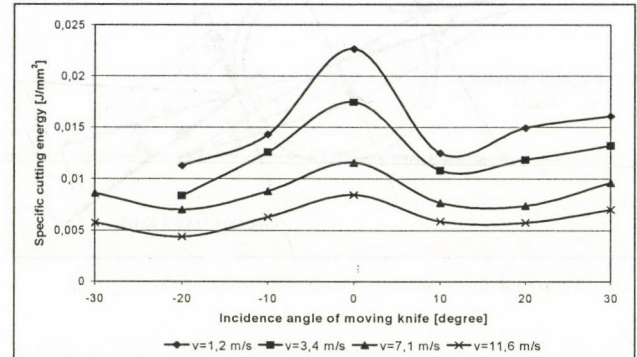

Diagram 3 Specific cutting energy plotted against the incidence angle of moving knife
(Kisvárdá 63 rye; $w=34\%$; $a=10$ mm, fixed knife 0°)

6. Conclusions, suggestions

On the basis of measurement it can be settled that cutting has the biggest specific energy-need. With increasing incidence angle of knives the specific cutting energy-need is decreasing. But it does not mean that from energetical aspect we have to aim at bigger incidence angle (slip). If slip increases the frictional loss will increase either. That is why an energetical optimum can be observed in the 15-20° intervals so the incidence angle of knives has to be set practical according to this value.

References

- [1.]BOGNÁR, J. - HENTZ, K. - SZENDRŐ, P.: Determination of Fast Moving Cutting Energy-needs and Development of Test Equipment. XIV. MTA Research and Development Conference, Gödöllő, 12-15 January, 2000 (poster)
- [2.]BOGNÁR, J. - SZENDRŐ, P. - HENTZ, K.: Equipment and Method for Energetical Measuring of Dynamic Chopping Processes. Agricultural Technology, 2000, XLI/5. 4-5 p.
- [3.]BOGNÁR, J. - SZENDRŐ, P.: Energetical Measuring of Dynamic Chopping Processes. XV. MTA, Research and Development Conference, Gödöllő, 23-24 January, 2001 (poster)
- [4.]MIKECZ, I.: The Machines of Animal Husbandry. Agricultural Publisher, Budapest, 1985. 15-46 p.
- [5.]STROPPEL, TH.: Zur Systematik der Technologie des Schneidens. Grundlagen der Landtechnik, 5/1953. 120-131 p.
- [6.]SCHULZE, K. H.: Über den Schneidvorgang bei Grashalmen. Grundlagen der Landtechnik, 5/1953. 98-116 p.

OUTFLOW AND ARCHING PROPERTIES OF GRANULOUS MATTERS (SUBSTANCES)

Zs. Szüle - B. Csizmadia - P. Soós - E. Domonkos - I. Oldal

Szent István University, Gödöllő

1. Preliminaries – goals of investigations

Researches in connection with materials in bulk have been going on for several decades according to the publications in the professional literature. These researches have been financed mainly by the companies producing pulverous matters or materials in bulk (e. g. cement-works, flour-milling, sugar or paint industry etc.). the thorough or more detailed knowledge on the flowing of materials has been necessary first of all owing to the precise weighing and feeding (or dosage) as it is required in the large-scale industries or farming.

In the cases when materials in bulk flow out of bins (containers, silo-sells etc.), the more precise outflow rate or quantity can be determined only by preliminary and usually expensive experiments. That is why, it would be important to get a more sophisticated knowledge about the outflow properties of the grains, feed-mixture matters, and other agricultural bulk-in materials, with special attention to the frequently altering moisture content.

The goal of the experiments has been the more exact cognition and determination of the factors influencing the outflow of the cereal grains or other matters in bulk used in the agriculture from a bin. Amongst the parameters, the outflow hole and its conic angle, the filling height and the inner friction factor (in bulk) have been investigated.

2. Material and method

A measuring cylindrical container was made for the nvestigation on the outflow of cereal and other plant's grains and we could tested the more important properties with its help. (The sketch of the measuring bin is demonstrated by Figure 1.)

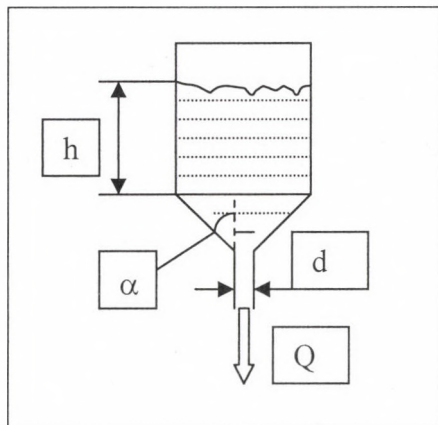

Figure 1 Layout of the measurement bin

Table 1 Important properties of the tested granules/grains

| Denomination of grain (granule) | Density (of body) (kg/m ³) | Bulk density (kg/m ³) | Moisture content (% w.b.) | Shape factor* | Inner friction factor (in bulk) μ_b |
|---------------------------------|--|-----------------------------------|---------------------------|---------------|---|
| Wheat | 1236.41 | 705.76 | 8.40 | 2.105 | 0.6459 |
| Corn | 1239.02 | 726.56 | 8.31 | 1.471 | 0.6013 |
| Oat | 1086.39 | 477.35 | 8.69 | 4.167 | 0.5829 |
| PE-LD Polythene granules | 898.51 | 528.67 | -- | 1.679 | 0.5873 |

*The values of the shape factor are the quotients of the grain - or granule-length and width measure.

During the investigation, four kinds of matter have been used, such as wheat, corn, oat grains and plastic granules. The main physical properties of the different particles are included in Table 1.

During the measurement of the mass flow values, the height of column or charge (h=40 and 80 cm) and the half-bevel angle values of the conic bin bottom ($\alpha=30^\circ$, 45° and 60°) and the diameters of the discharge tube (d= ϕ 50 and ϕ 100 mm) have been changed.

3. Tests results

Here the measured data of corn (selected from the results of other grains or granules) are published. Table 2 includes the mass flow values belonging to the individual set positions and the diagram constructed on the basis of Table 2 can be seen in Figure 2.

Table 2 Measured mass-flow rates of corn outflow

| d (mm) | K- α 60-h80 | K- α 30-h80 | K- α 60-h40 | K- α 30-h40 |
|--------|--------------------|--------------------|--------------------|--------------------|
| 0 | 0 | 0 | 0 | 0 |
| 50 | 0.396397 | 0.556478 | 0.385032 | 0.523791 |
| 100 | 2.703854 | 3.327402 | 2.756909 | 3.403606 |

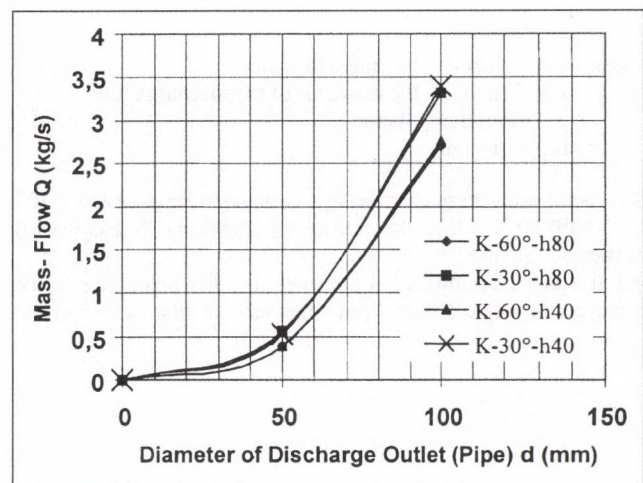

Figure 2 Measured mass-flow values in the function of discharge outlet diameters at corn outflow

Figure 3 includes the relationships between the diameter of the discharging pipe and the mass-flow values for all the grains (granules). It can be established that the outflow rates of the grains (granules) have changed accordance with the inner (bulk-in) friction factor – usually lower mass-flow rate values have been measured in the case of the materials of smaller inner friction factors. A parabolic curve can be fit onto the measured points of the outflow at a high accuracy ($R^2=0.95$) and there the co-efficient of x and its exponent b are the characteristic properties of the material and the measurement conditions.

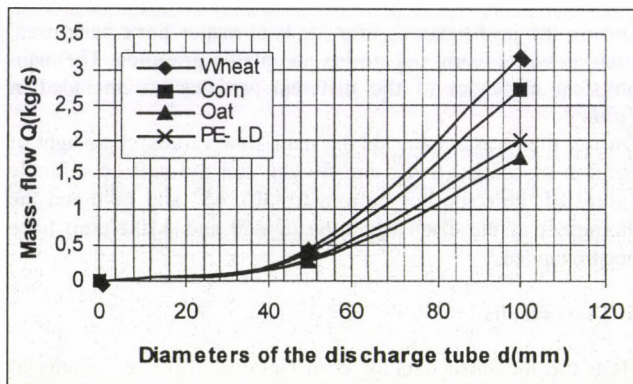

Figure 3 Mass-flow values at the outflow of four various types of grain ($\alpha=60^\circ$, $h=80$ cm)

4. Evaluation

4.1 A relationship has been elaborated between the mass-flow rates and the diameter of discharge tube in the case of the actual tests (wheat, corn, oat grains and plastic granules) that gives reliable and applicable results for calculations at the same conditions like the experiment. The mass-flow rate in the function of the diameter values of the discharge tube has been a parabolic curve and its general form is as it follows:

$$y = a x^b$$

where $y = Q$ (kg/s) : the mass-flow rate
 $x = d$ (mm) : the diameter of the discharge tube
 a – multiplying factor
 b – exponent

The factor a has been changed in a quite wide range ($9.861 \cdot 10^{-6}$ to $1.049 \cdot 10^{-5}$) while the values of exponent b has varied between 2.52 and 2.8.

4.2 It can be established the curves in pairs belonging to the same conic angle almost “run together” i.e. the height of the

matter column has not influenced the mass-flow values. The mass-flow values have been higher at smaller conic angle of the outlet (30°) than at its bigger value (60°).

4.3 At one of the curves running together, the height of layer has been 80 cm and – 40 cm at the other. It has verified the statements represented in the earlier articles published in the professional literature, i.e. the outflow rate does not depend (or depends only at a very low degree) on the height of the grain column.

4.4 All the curves have ran together approximately in the cases of plastic granules and wheat grains from which it could be concluded that the conic angle of the outlet (at the given sizes) influenced only at a low degree the values of mass-flow.

4.5 When the changes in the mass-flow values of the four different kinds of particles have been drawn in the same diagram, it could be established that the parabolic curves were separated at the values $\alpha=60^\circ$ and $h=80$ cm. The order by the value has been: wheat, corn, oat and grains (granules) and that must be clearly in connection with the values of inner friction angle and pile.

References

- [1.] R. KVAPIL (1959) „Theorie der Schüttgutbewegung”, Berlin 1959.
- [2.] H. KOHSIEK (1968) „Betrachtungen über das Befüllen und Entleeren von Vorratsbehältern für Schüttgüter”, Grundlagen der Landtechnik Bd.18, 1968 Nr. 5
- [3.] TOMAY T. (1982) „Keveréktakarmány gyártás” (*Manufacturing of Feed Mixtures*) Műszaki Könyvkiadó, Budapest 1982.
- [4.] CSIZMADIA B. (1998) „Einige Bemerkungen über die natürlichen Gewölbebildung in Konstrukturierten Haufen” *Metode experimentale si ... Konferencia Temesvár, 1998.*
- [5.] OLDAL I. (1999) *Természetes boltozódás kísérleti vizsgálata (Investigation on Natural Arching of Granular Materials)*. TDK dolgozat, SZIE 1999.

EXPERIENCES IN A LARGE - SCALE DAIRY FARM APPLYING PRECISION ANIMAL KEEPING TECHNIQUE

L. Tóth, Szent István University, Gödöllő
J. Bak, Hungarian Institute of Agricultural Engineering

1. Introduction

The main part (65 %) of the stock of dairy cows is represented by about 900 large-scale dairy farms (altogether 270,000 cows) in Hungary where Holstein-Frisian breed with high-rate of blood is typical. The mechanised milking in parlours and the loose housing exist in 83 % of these farms. The average lactation milk yield is 6,700 litres per cow in a year and the average number of animal is 350 cows per farm. There are 220 dairy farms where the specific milk production is 7 to 11 thousand litres per cow in a year.

There are 130 to 140 thousand cows of mixed-up species at around 40,000 small-scale farmers. They are really (mostly) constrained entrepreneurs and the major part of them applies confined housing systems with 1 or 2 cows.

On the base of the above listed facts, it is understandable that our investigation and development connected to the precision animal husbandry have been focussed on the large-scale dairy farms.

2. Material and method

The properties of the tested dairy farm are as it follows.

- The animal herd includes 810 Holstein-Frisian cows.
- The TMR feeding (feed distribution) is solved by a feeding wagon with a 3-screw-mixer, three times in a day.
- There is an abreast (parallel) parlour with 2x20 stalls type Bou-Matic in the investigated farm. The milking system is equipped with a cramming gate to press the animals into parallel position and quick animal releaser system. 2 operators (milkers) and 1 animal driver work in the milking parlour.
- The computer program includes the software Pro Vantage and RISK A 2000.
- The identification of each animal is solved with the help of a collar-suspended (passive) transponder one by one at the entrance gate. The reading of the activity ('pedo-') meters is solved there as well.
- There are devices for measuring the quantity and conductivity of milk at every milking stall.
- An animal-weigh-device (automatic) is applied.
- A selector gate is built in the drive-back way.
- The yearly milk yield is 9200 litres per a cow.

Milking method:

- Previous disinfecting with immersing the teats into a solution (Pregold)
- Wiping (drying) the teats with the help of a once-usable paper towel.
- Putting-up of the milking unit (by hand).
- Automated removing of the milking unit.
- Immersing off teat into a solution i.e. teat-handling after milking (Uddergold)

The goal of our investigation was to examine and evaluate the technical – technological factors influencing the capacity (cow flow) of the milking parlour and to realise a more effective co-operation between the operators (milkers) and the milking equipment and the milk-cows. On this base, the detailed purposes were as them follow below.

- The increasing trend of the specified milk yield cannot decrease and even it should grow.
- The time, when the milking unit is on the teats, should be decreased below a suggested limited value.
- To milk more cows in the same working time.
- The total capacity (milked cows per an hour) of the milking parlour is to be grown.

- Improving the preparing process of udder performed (with the higher carefulness in handling).
- The empty milking (when the milking stops for a time of while or finally but the milking unit works on) is to be decreased or eliminated (in the way of reducing the retarding (delaying) time of the detaching of the milking unit).

The expected results were as them follow:

- The condition of teat-ends (tips) should be better (because of the shorter time under vacuum).
- The ratio of cows with udder inflammation (mastitis) at he clinical status is to be decreased.
- The frequency and rate of the "kicking-off" and "falling-down" of the milking units is to be reduced.
- To make possible the priority of the selection of the herd in accordance with the milking time.
- The easier and quicker accommodation of the heifers to the milking machine should be solved.

The self-testing program of the software Pro Vantage was applied for determining the capacity (the number of milked cow per an hour) of the milking parlour and for examining the condition (technical state) of the parts of the milking equipment. For determining the results of the changes in the setting of milking equipment, the data counted and evaluated by computer programs Pro Vantage and RISK A were used. The instrumental control tests of the milking equipment were carried out according to the standards ISO 5707 and ISO 6690 (valid from 1996).

As a first step, we carried out a program as it follows:

- the correct work of the milking equipment was tested monthly with the help of instruments,
- we evaluated the milking method (of milkers) and made the operators understand the elements and advantage of the above described milking method,
- we modified the setting of the teat-cup-removal unit as it follows (See Fig. 1):

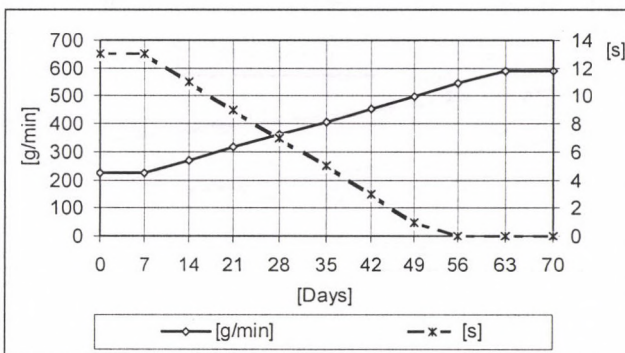

Figure 1 The time program of the experiment
- set value of the milking flow for detaching the milking unit from teats (g/min)
- retardation time of detach unit (s)

- first setting the removal unit in the beginning of the test
- the milking flow value for starting the removal was set to 223 g/min,
- the retardation time of detaching the milking unit was 13 s,
- the milking term was not limited, it was in accordance with the demand of each cow.
- changes in the settings every week (7 days) by the following degrees:
 - the increasing in the milk-flow limit starting the detaching unit was set with the value of 46 g/min week by week,
 - the retardation (delaying) time was reduced by 2 s every week.
- the final setting was done after 48 days:
 - the milk-flow limit for starting the automatic removal of the milker unit was set to the value of 589 g/min,

- the retardation time was set to 0,
- the milking time still remained unlimited according to the demand of each cow.
- The next change in the setting was done after another 4 weeks:
- Keeping the above described set-values, we limited the milking time (more exactly the time while cows are in the milking parlour) to 12 minutes as a maximum value.

3. Results

The growing of the milking-parlour capacity or *parlour cow flow* (the number of cows milked in one hour) is shown in the diagram of Fig. 2. and the changes in the specific milk yield and the average values of milking time are dotted and analysed by the diagram of Fig. 3. The testing program was carried out from December in 1999 and January in 2000 till September in 2000.

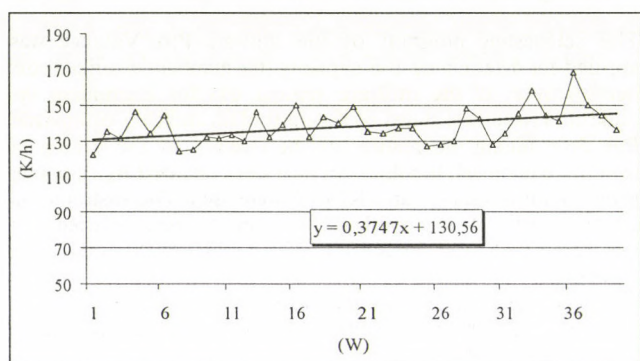

Figure 2 Parlour cow flow (capacity of milking parlour)
 - (W): number of weeks from the beginning of experiment
 - (K/h): number of milked cow in an hour

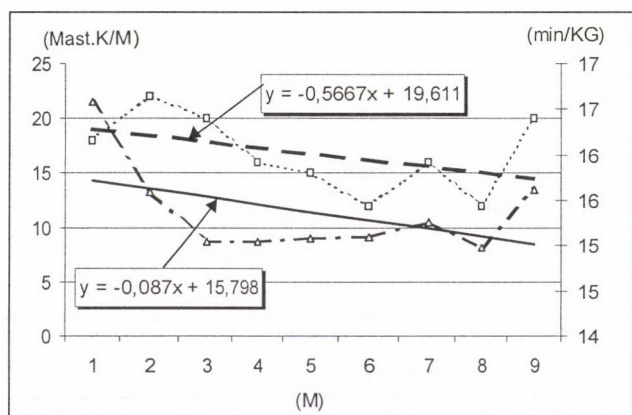

Figure 3 Changes in the number the cows infected with udder inflammation (mastitis) and in the total milking time for a cow during the experimental time
 - (Mast. K/M): number of cows selected because of mastitis in the different months during the experiment
 - (min/KG): total milking (work) time for a cow group
 - (M): number of month from the beginning of experiment

During the evening milking shifts the capacity of parlour altered between the values 120 and 170 cows per hour in the different days. The average value of the parlour capacity increased from cca. 120 cows per hour to almost 150 cows per hour. (See Fig. 2.) The total milking time of a cow (considering the milking shift three times a day) decreased from the beginning value of cca. 16.5 minutes to the value between 15.0 and 15.5 minutes. The daily specific milk production increased from the beginning value of 28 litres/cow/day first to the value of 30 litres/cow/day and then it decreased to value of 26 to 28 litres/cow/day. The decreasing in specific milk yield was experienced in the earlier years during the warm summer months, too.

| Process properties | Conventional values | Suggested values |
|--|--|------------------|
| The milking flow velocity at starting the removal unit | 226 g/min | 589 g/min |
| The retardation time of the removal | 13.0 s | 1.0 s |
| The time-schedule of the changes in setting: | 50 g/min/week in the milking flow velocity value for switching on the detaching unit 1 to 2 s/week in decreasing the retardation time of detaching unit | |

Argument

The following results could be realised with the help of feeding back the data collected and analysed by computer into the production process, including the precision technique of the changes in the setting of the milking unit and the more effective co-operation of the milking equipment and the operators (milkers) and the cows:

- the specific milk production level increased in the year 2000 in comparison with the yield in 1999, the growing difference was cca. 600 litres/cow/year,
- the time while the milking unit was on the udder of a cow (taking into consideration the total time of the daily 3 milking shifts) decreased by about 2.0 to 2.5 minutes,
- the capacity of the milking parlour (*the parlour cow flow*) increased from the value of about 130 cows/hour to cca. 150 cows/hour so now more cows can be milked in the same work time,
- increasing the milk flow velocity limit for starting the removal and eliminating the detach retardation time, the so called "empty (or blind)" milking disappeared,
- the condition of teat tips has grown better,
- the number of the cows in the clinical status of mastitis (udder inflammation) was 18 to 22 at the first milking in the beginning and during the months after changing the unit setting - 12 to 16, conclusively it decreased,
- the number and rate of unit kicking - off (when cows kick off the milking unit from themselves) was decreased and stabilised after the changes in the setting of milking equipment (e.g. 18 cows kicked off the unit amongst 637 cows during a milking i.e. the rate of kicking-off was 2.8 %,
- the selection of cows by milking time became important and, during the experiment, altogether 12 cows was problematical after limiting the milking time at the value of 12 minutes
- the average milking time of the animal groups with heifers after fresh calving was longer (2 to 3 minutes more) by the experiences and the very long milking time and the bigger number of unit kicking - off was more frequent,
- the udder preparation has grown better with the more careful work (with appropriate attention) and the cows entering the milking parlour were cleaner.

References

- [1.] EICKER, S.W. AND STEWART, S.C. 1998, Computerised Parlour Data Collection and Use: "Monitoring the Cows, the People and the Parlor". Proc. 37th Annual Meeting of the NMC.
- [2.] REID, D. A. AND STEWART, S.C. 1997. Effects on Parlor Performance by Variations of Detacher Settings. Proc. 36th Annual Meeting of the NMC.
- [3.] STEWART, S.C. AND EICKER, S.W. 1998. Practical Computerised Monitoring of Parlor Cow Flow. Proc. 31st Annual Meeting of the Annual Association of Bovine Practitioners.
- [4.] BRAMLEY, BRAMLEY, DODD and MEIN. 1992. Machine Milking and Lactation
- [5.] BAK J.: Jelentés a fejőházak áteresztő-képességét befolyásoló műszaki-technológiai tényezők vizsgálatáról. 2000. FVMMI Gödöllő, 110 old. (Report about Test on Technical-Technological Factors Influencing the Capacity of Milking Parlours. 2000. FVMMI Gödöllő, 110 p.)
- [6.] Bak J. - ANTAL L. - PAULISINETZ J.: Jelentés a tehenészeti telepek fejéstechnikai és higiénés ellenőrzéséről. 1999. FMMI, Gödöllő 117.old. (Report on Milking-technical and Hygienic Control of Dairy Farms. 1999. FMMI, Gödöllő 117 p.)

OBTAINED RESULTS OF DIESEL ENGINE DEVELOPMENT SO FAR AND THEIR EFFECT ON POWER TRANSMISSION

A. Vas - Z. Lajber

Szent István University, Gödöllő

In the last few years a large-scale development has started and ripen in the diesel motor technique. These are the generalization of charging, alteration of characteristic of charger compressors, considerable increase of charging at lower engine speeds, in this connection the regulation of charging and generalization of fuel recooling. The direct injection and those combustion chamber and fuel flares which meet better the new requirements have become dominant.

Because of new improvements and in connection with this the numerous new technical solutions the outsider can register two phenomenon. At the 1-3 liter displacement volume category – first of all at diesel engines of cars – a considerable, approximately twice bigger engine rpm. has been developed. The other experience is from the area of commercial vehicles (tractors, vans) such as providing high margin of torque and raising of torque flexibility up to $k=1,5-1,7$.

Both of developments mainly have been ensured with changing of conditions of carburetting. As utilizing the benefits of advantageous relatively high air excess it had to reach the reduction of space of time demand of carburetting – combustion. The results could have been achieved with the improvement of internal and external conditions of carburetting and the application of new findings of electronics, control engineering.

Increase of diesel engine speed

The larger increase of diesel engine speed could have been reached with changing of conditions of carburetting, using of electronics, and developing of electromechanical / electrohydraulic systems for at all times using. Therefore the condition of increase of nominal speed is the reduction of the carburetting and combustig period which supply the local conditions. It can be achieved with the practical configuration of combustion chamber and fuel flare, the optimization of injection controlling which take more parameters into consideration, and the minimum time of fuel flare building.

Nowadays the fuel-injection pump is controlled and optimized by a central electronic controller (ECU) which consider more perceived parameters. With this control a revolving distribution fuel-injection pump can be seen in the first figure.

The controller intervenes in the process according to the perceived signs. The dose is controlled, adjusted, and suppressed by the controller. These controllers replace the role of regulator.

There are two ways to make better the conditions and decrease the period of carburetting namely such as to set up the practical fuel flare system and to increase the injection up to a multiple value. The figure 2. presents well the connection between the injection pressure (p), the length of fuel flare penetration (s), and the time of forming. There is an essential aim that the length of fuel flare should not be too long, and the injected fuel should the more smoothly fill up the combustion chamber. Usually it can be reached by manifold, asymmetric injector, directed air flow and special headed piston.

The high pressure and the reduced carburetting time claim new requirements against the injection system too. While the carburetting time reduces considerably the ignition delay changes hardly. It's common knowledge that the injected charge rate under the ignition delay influences the hardness of engine running. But it is practical to reduce the hardness of engine running. For this reason one of the way of development has aimed at that controlling which describe unambiguously the

injection characteristic free from flexible elements. This aim has been accomplished by the different electronic controlled injection systems (Nippondenso, Common Rail, etc.).

Usually the high pressure electronic injection systems (figure 3.) have not feed pump. The fuel is transmitted towards the distributing pipe by an adjustable high-pressure pump and the distributing pipe is connected with the electric controlled injectors without intermediary pipeline. The whole system is controlled by an electric control unit (ECU). The controlled injector can control the dosage, the whole time of injection, and the dispersion in this injecting time, in this way the characteristic of injection too. In this way it can reach that the most properly adjusted engine under any kind of work conditions can work with energy-saving and minimum environmental pollution. Using the electronic controlling you can generate even quadrate wave (figure 4.). But the engine running becomes hard in this way. Therefore a spring device is placed between the injector top and switching magnet to convert more or less the quadrate sign from the switch into trapeze so the injection characteristic can modify too.

Increase of margin of torque of diesel engine

The other result of diesel engine development is the increase of margin of torque or as the classic terminology expresses increase of the engine flexibility. Recently the increase of engine flexibility has achieved such a degree that the engine power stays at the nominal value while the engine speed falls. Which can be achieved by considerable increase of engine torque.

Therefore these engines are named constant power engines too. You can use them for the middle and the higher power category so their using is typical at tractors and vans. Increase of torque flexibility improves the engine and by this means the dynamic relationship of the vehicle to make more economical the working of the machine. The increase of torque flexibility is limited by the air-fuel ratio, excess air factor, and the inner carburation helping relations of the engine.

At boosted carburetter diesel engines- which have better power and fuel consumption conditions because of their working method – the increase of flexibility factor and the constant power of rpm. zone (figure 5.) can be reached quite simply whit the modifying of characteristic of charger. This solution is named combined charging. The working of the engine like this is described by increase the flexibility, and the constant power at wide rpm. zone.

The margin of torque alias torque flexibility can be increased considerably by using of electronic control. The control even can increase the dosage with 50 % therefore the flexibility of the engine can be increased up to 1,5-1,6 (figure 6.). The torque increasing effect and with this the constant power part of the characteristic is achieved by the electronic control with the controlled realization of dosage (Δv) on the free part of the regulating characteristic. This effect is attained at partial load.

The constant power engine doesn't practical to use on the regulating part of the characteristic because of big margin of torque which is typical of the free part of the characteristic because it will be reduced one of it's benefit such as the available more advantageous fuel consumption. This dilemma appears especially marked in connection with constant power tractor engines. If we use these engines in a classic way we have to give up a part of the offered benefit.

Changing requirements against power transmission devices

Both the increase of rpm and the using of constant power engine effect the power transmission devices. From these devices the gearshift, and the choosing of gear of gear hub are mainly influenced. With increase their rpm. the diesel engines

approximately got the usual rpm. zone of gasoline engine. There is a difference between the bigger torque, and the distribution of torque. It doesn't claim major difference in construction. The benefit of constant power engine is the low fuel consumption which can be observed at the free part of the characteristic in addition to the extremely high flexibility. The high $k=1,4-1,6$ flexibility can ensure stable working conditions at the free part of the characteristic. Although this part can result in 40% decrease at the engine rpm. This decrease can be observed at the velocity of vehicle too. Therefore a throw-back is necessary by all means.

There are much more problems appear about the constant power engines if we want to utilize the benefits. Most often the maximum engine rpm. changing can be $\pm 10\%$ at the drawn and the driven machines. This means that the engine have to be worked with 85-90 % power utilization at the regulating part. With such an adjustment like this the energetic benefits of constant power diesel engine just partly can be utilized. The most simple way to utilize the energetic chances is the automatic gearshifting. We have done research works to identify the algorithm and we used the computer simulation.

Simulation of gearshifting points

The aim of the finished examination is to examine the gearshifting by graphically, and the chose gearshifting points (course program) how effect the energetic relations. It's method is the executing of simulations with using the produced model which had been created on the evidence of the finished drawing measuring, and the engine measuring with braking. The data of

a New Holland 160 typ. machine has been used for the simulation with 5-42 kN drawing power load, and shifting between B gears. In this case the travel speed has changed between 4-18 km/h depending on the load.

The dynamic model of the tractor has approx. 220 parameters in all which have to take into consideration according to the adequate algorithm. The main modules and their features are shown by the figure 7. The data of the engine are gained from the regulating characteristic which belongs to the full load. The setting of total gear has been taken into consideration according to the gears of gearshift and gear hub. The further parameters of the tractor as geometric dimensions, tyre dimensions, torsion features, slip- adhesion factor curve, are have been built into the algorithm. In the program the logical algorithm which task is to pick out the gears has got into as a separable block therefore it can change and enlarge any time.

The results of running of (course diagram) have been got in the form of chart and diagram (figure 8.). We especially want to turn your attention to the number of gearswitchings, and their course. In every chases a different diagram has been made for the switching algorithms (figure 9.).

It can be stated after the evaluation of simulation that there are different kind of algorithms are used the best for the reaching of the aims of the examinations for different conditions. The best working mode for the getting of the area capacity is the constant engine power working mode which is fitted to the gearshifts. The best help for the calculating of the engine efficiency is that processing which is from the drawing characteristic. Finally, the best working mode with you can determine the drawing efficiency is the constant power working mode.

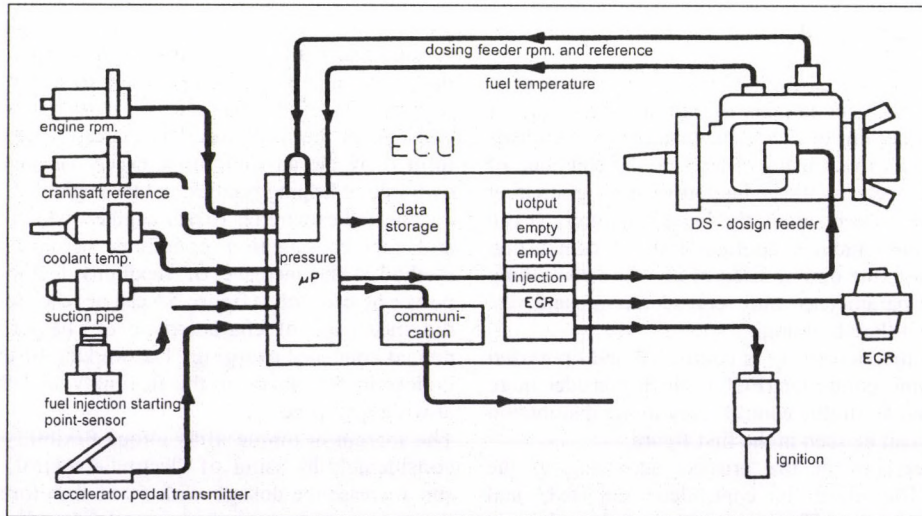

Figure 1 Electronic controlled injection system (ECU)

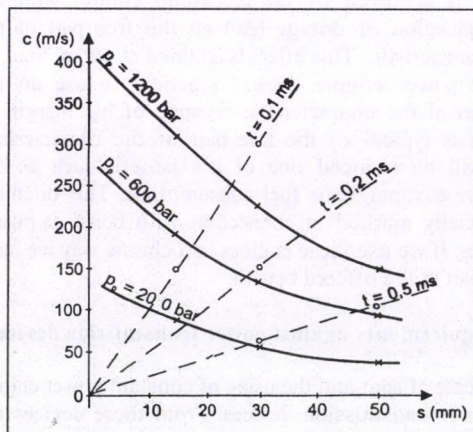

Figure 2 The pressure affect the injecting parameters

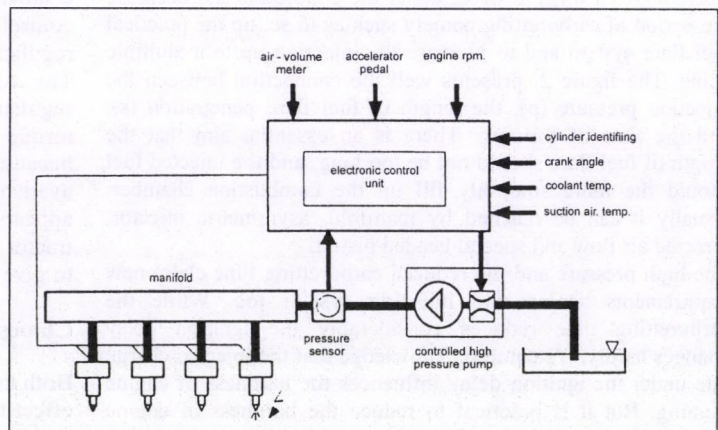

Figure 3 Electronic injection (Common Rail)

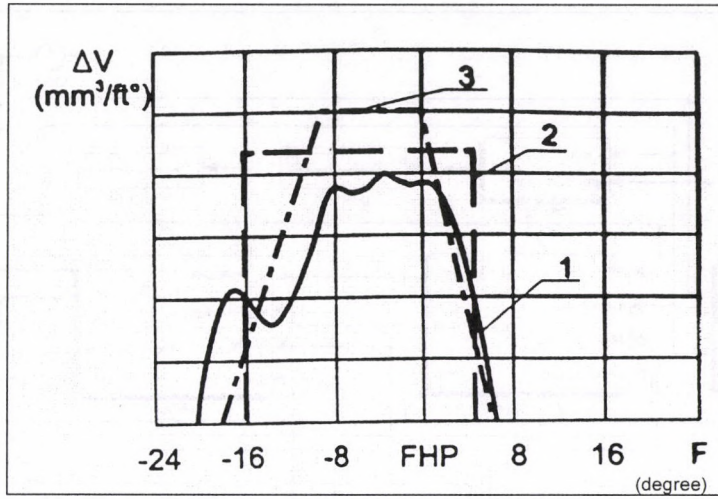

Figure 4 Injection characteristic

1.- with rotary piston dosing feede, 2.- theoretically possibility, with electronic dosing feeder, 3.- with electronic dosing feeder

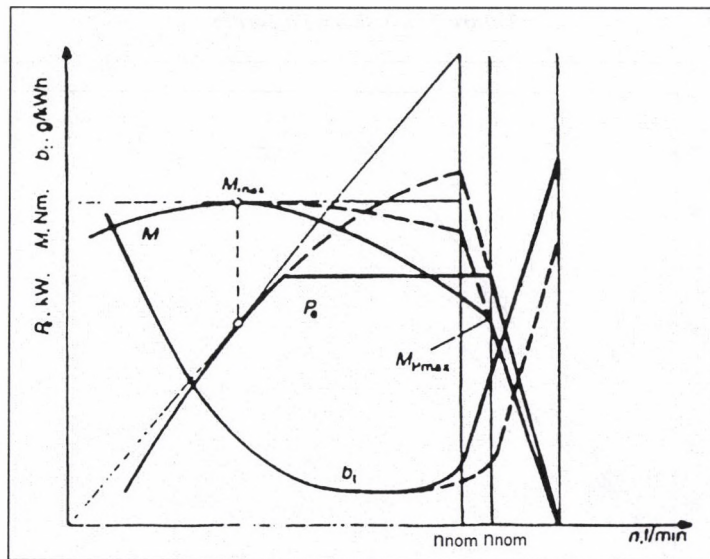

Figure 5 Characteristics of constant power diesel engine with combined charging

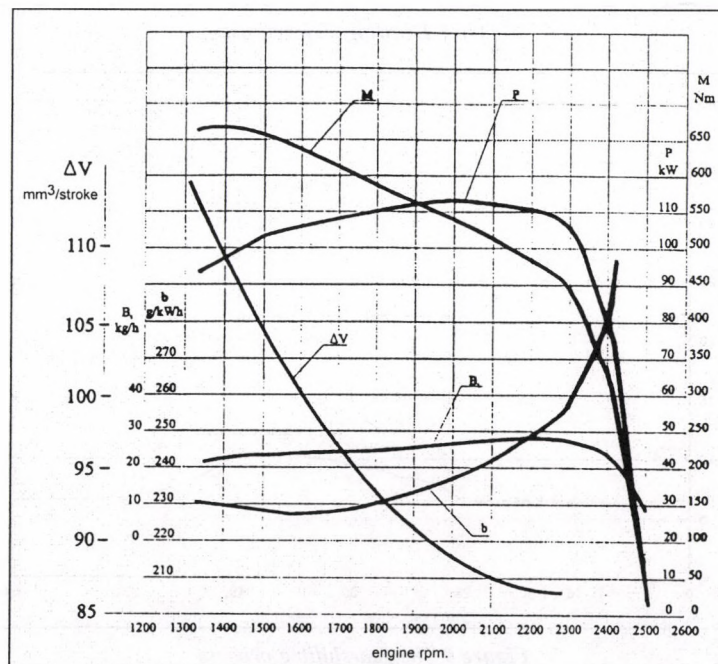

Figure 6 Constant power diesel engine regulator characteristic

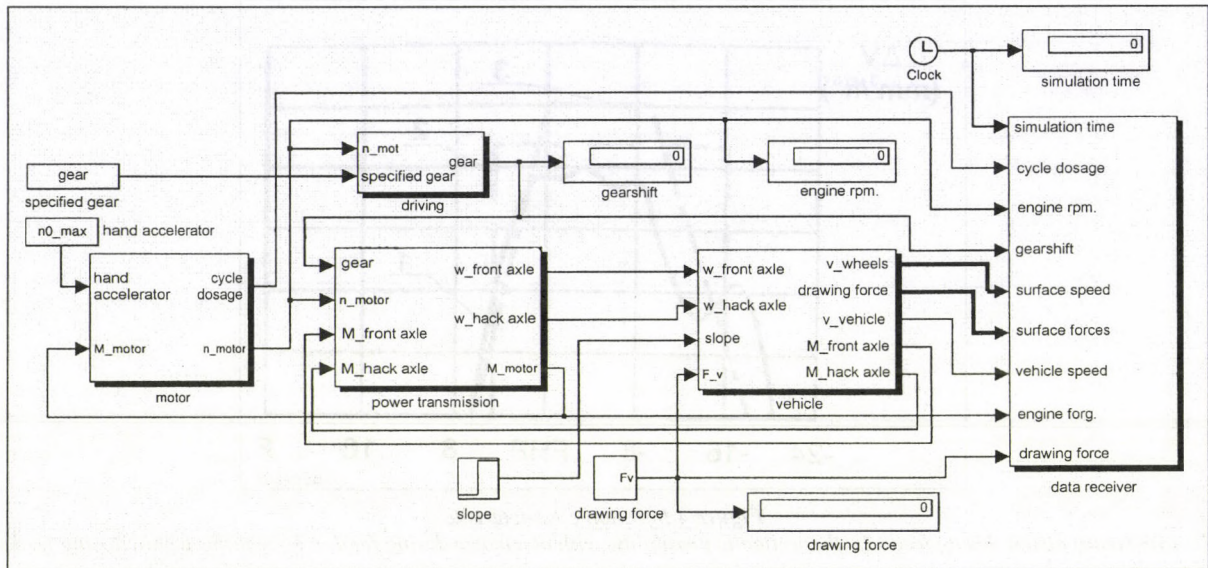

Figure 7 Gearshifting algorithm

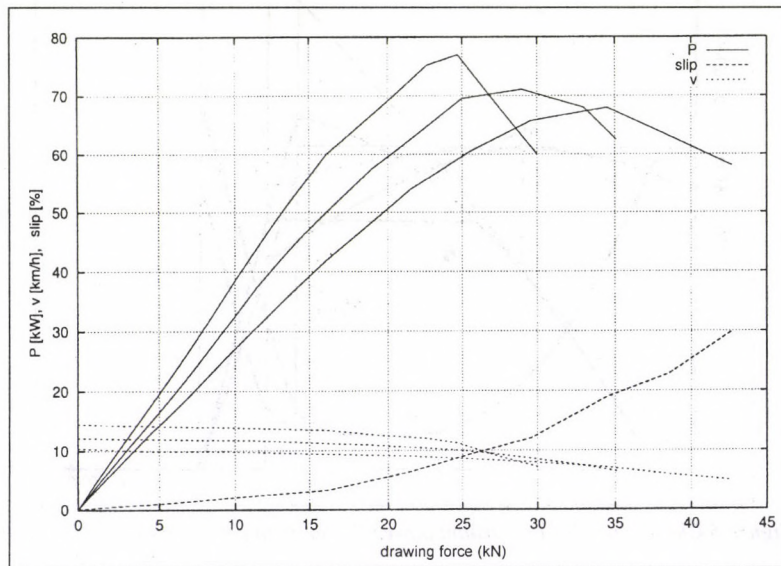

Figure 8 Drawing characteristic

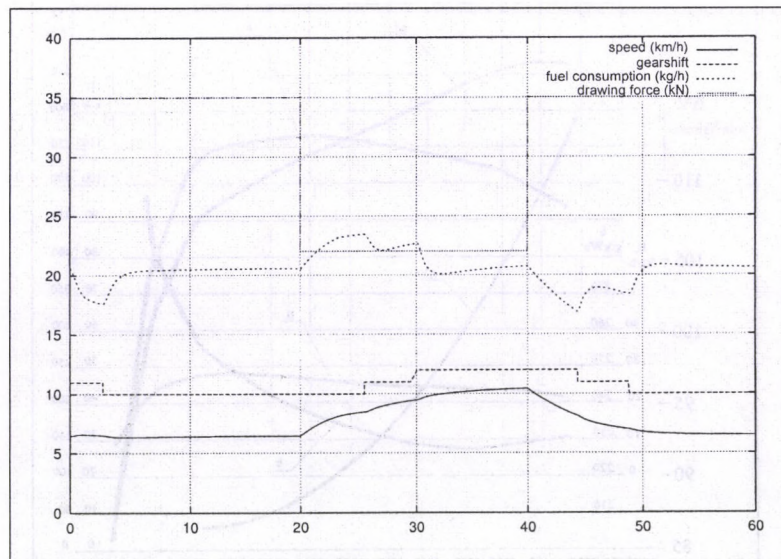

Figure 9 The gearshifting process

COMPUTER AIDED PLANNING AND INFORMATION SYSTEM FOR PLANT PRODUCTION

J. Benkő - I. Husti
Szent István University, Gödöllő

1. Introduction

In the last decades the method of production management went through a huge improvement. Nevertheless, not only the methods, but with the arrival of the computer era, the devices have also been changed. Computer aided production management integrates the planning and the production. Expenditures and costs became continuously controllable during the whole production period. The production means and materials can be used up with less costs and more security. An important advantage is that the management gets immediate and precise information. All these facts do improve the efficiency of the production management and the profitability of the company.

The endeavour for improving production management has certainly touched the agriculture as well. However, planning software available for the sector are far less than for the industry. Presumably, the reason is that in Western Europe the smaller farm sizes have not required this advanced management method and consequently they have not got to sphere of interests of the leading industrial software developers yet. As to the Hungarian software developers concerned, we guess, they have not realised the changes and demands yet. Experience shows that industrial applications can hardly be adapted to the agriculture because of the characteristics of agricultural production. It seems to be more reasonable to develop special software covering the agricultural characteristics. In this presentation we have the pleasure to give an account of our development experiment in this respect.

2. Development and system expectation

The main targets of the plant cultivation management system (PCMS hereinafter) are coming from what discussed in the Introduction of this study. The management system should make a more exact cost accounting possible where expenditures influence the profitability of plant cultivation to a great extent.

Primarily: The system should ensure in field, branch, self-financing unit breakdown

the separation of operational costs (energy, material, spare parts, wages, et cetera) of the different machines (tractors, lorries, self-powered machines, working machine, etc.) and the measurement of mechanical work in natural units (ha, t, hour, etc.) to make the costs comparable with the work;

the registration of production inputs (seeds, nutrients, insecticides, fuel, etc.) in quantity and value;

the registration of human work.

Secondly: in the knowledge of the cultivation technology and the resources (human work, machine, material), which are part of the database, the system should aid the planning, its automation and the operational management of the cultivation.

At outlining the targets and its solution you have to remember that the cultivation management system should fit into an existing accounting system including the subsystems of tangible assets and inventories. From the very first minute of the planning phase it was a necessity to ensure that the introduction of cultivation management system will not hurt the accounting system and even more, in order to avoid parallelism and multiple data recording, it has to promote the existing system with data exports.

The cultivation management system is connected with the accounting system in more points. Transactions between the

two systems are the rundown on inventories and the depreciation, on one hand, at the input side of the management system and the wages and work quantities at the output side on the other. The system is modular to be ready for further development and enlargement of database.

3. The principal structure and the database of management system

Figure 1 shows the rough structure of the cultivation management system, the most important elements of which is the database. The database contains the data, which are necessary for the operation of the system, organised into data tables, the forms necessary for data input, the queries necessary for making reports and statements, the reports to be printed and the modules (program codes) suitable for different calculations [1].

The data tables of the system can be classified into three groups: base (primary) data, daily data and planning data.

Primary data are the longer-life data. They change seldom in relations with workers, machines, materials, technology, operation, land, etc. Sources of the primary data are the existing registers, documents, catalogues.

Daily data are registered from basic documents (work-sheet, waybill, stock-turnover sheet, payment order, etc.) All the information can be found in these documents in connection with the production (name of the operation done, quantity of the work, time consumed, materials and their quantities used up in the operation, who has made the operation and to whom favour, etc.). These information are all inputs and can be measured both in kind and value.

Feeding table of base data properly into the computer is the primary condition of the reliable system operation. Proper feeding means that primary documents are available and the data on them are authentic and accurate.

Output information (REPORTS AND LISTS) making possible to monitor the cultivation process and to promote the management turn up at the output side of the system as a result of several data sorting and reductions (Figure 1). Naturally, the headings in the frames can be enlarged. It is also possible to show the data in graphic charts.

Furthermore, an important element of the output side is the completion of the document called 'Wage accounting of the workers'. This certificate is required by the book-keeping. In principle in this point the two systems, namely the cultivation management and the accounting system, can be coupled

We took general planning requirements into consideration as well at planning the database. We use the easily understandable terminology of Microsoft Access for the description of the system. We developed the system in these surroundings. In Microsoft Access terminology an object with records and fields for storing data in a certain topic is called table. Among others (forms, queries, reports), database is composed from tables that can be linked together.

4. Operation of the planning module and its characteristics

The PCMS not only can trace the cost formation but it has unique characteristic is that the system is suitable for time-sequence planning and cost calculation of all the machine works and material demands in plant cultivation by fields and branch. This experiment can be considered as the first step on the way to approach agriculture to industry where integrated production management systems with similar tasks have been working for years. The dream can be realised that agricultural engineers, just as their mates in the industry, sitting in front of a computer screen without pen and paper can plan the forthcoming cultivation period and evaluate the available resources.

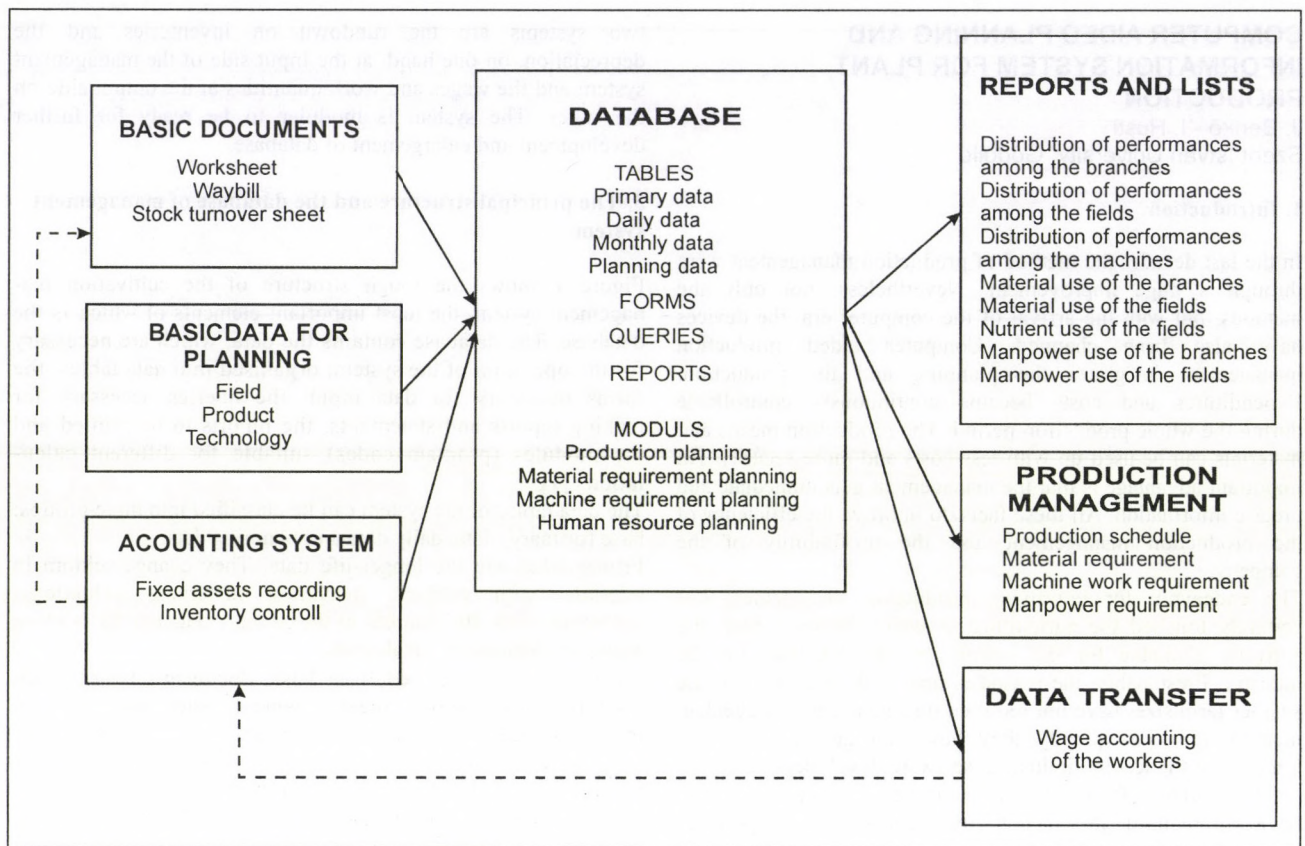

Figure 1 Scheme and operation of the management system

After having fed some input data (field, product, technology,) the planning module automatically makes the very time-consuming planning process. The result of the planning is a cultivation program, in chronological order, that can be broken down to branches and fields. Furthermore, the other outcome of the planning is the machine-work and material requirement, manpower and time demands for the cultivation process (Figure 2).

Basic data of the planning can be found in the previously introduced primary data tables, more accurately in the field, product and technology files. It goes without saying that the success and the exactness of the planning depends on how authentic the content of these tables are.

We remark that the technological description in the database has been widened by more new elements in comparison with the existing, traditional technological lists where name of the operations and its beginning and the end are listed in chronological order. The reason is that the automation of planning made it necessary that the specific demands of operations, materials and time (demand per unit area) to be added to the different operations in the technology table. At the same time the links among technology, operation group and material files provide the opportunity for calculating the costs of machine works, manpower and materials.

Planning can be realised in two phases. The steps of the first phase are: selecting the fields, providing the year of cultivation, the plant culture, the plant variety and the cultivation area. The last data is necessary because cultivation area is not always equal with the total area of the field. Parts of the field can be fallow or another reason can be that the field is divided among more plant cultures.

The second phase of the planning is the calculation of the detailed operation and material requirements. You only have to

select the cultivation technology and the program will complete the planning automatically by a single command. The program computes the machine-work demand in HUF, in natural unit and in normal hectare for operations, the required materials according to technology in value and in kind again and the expected time requirement as well.

The automatically planned production schedule for the selected field is the adaptation of the range of operations fixed in the technology table. In case of demand the schedule may be modified. We can delete operations, select new operations and materials, change the specific machine-work and material demands. In the interests of speeding up the planning and making it more comfortable there is a possibility to switch on or off the elements of the operation as you please.

This production management software might become an important aid in the plant cultivation management. The advantages achievable by the application of the costs monitoring module consist of the continuous and exact monitoring of the expenditures and labour use. The strength of the planning module, on the other hand, is that the different plan variants can be produced fairly fast with hardly any manual work saving time for the planning engineers for more sophisticated works.

References

- [1.] BENKŐ, J.: Növénytermelés irányítási rendszer (NIR). (MS ACCESS alatt fejlesztett termelésirányító és tervező szoftver személyi számítógépekre), Gödöllő, 2000.
- [2.] HUSTI, I.: A mezőgazdasági gépesítés ökonómiaja és menedzsmentje. Mezőgazdasági Szaktudás Kiadó. Budapest, 1999.

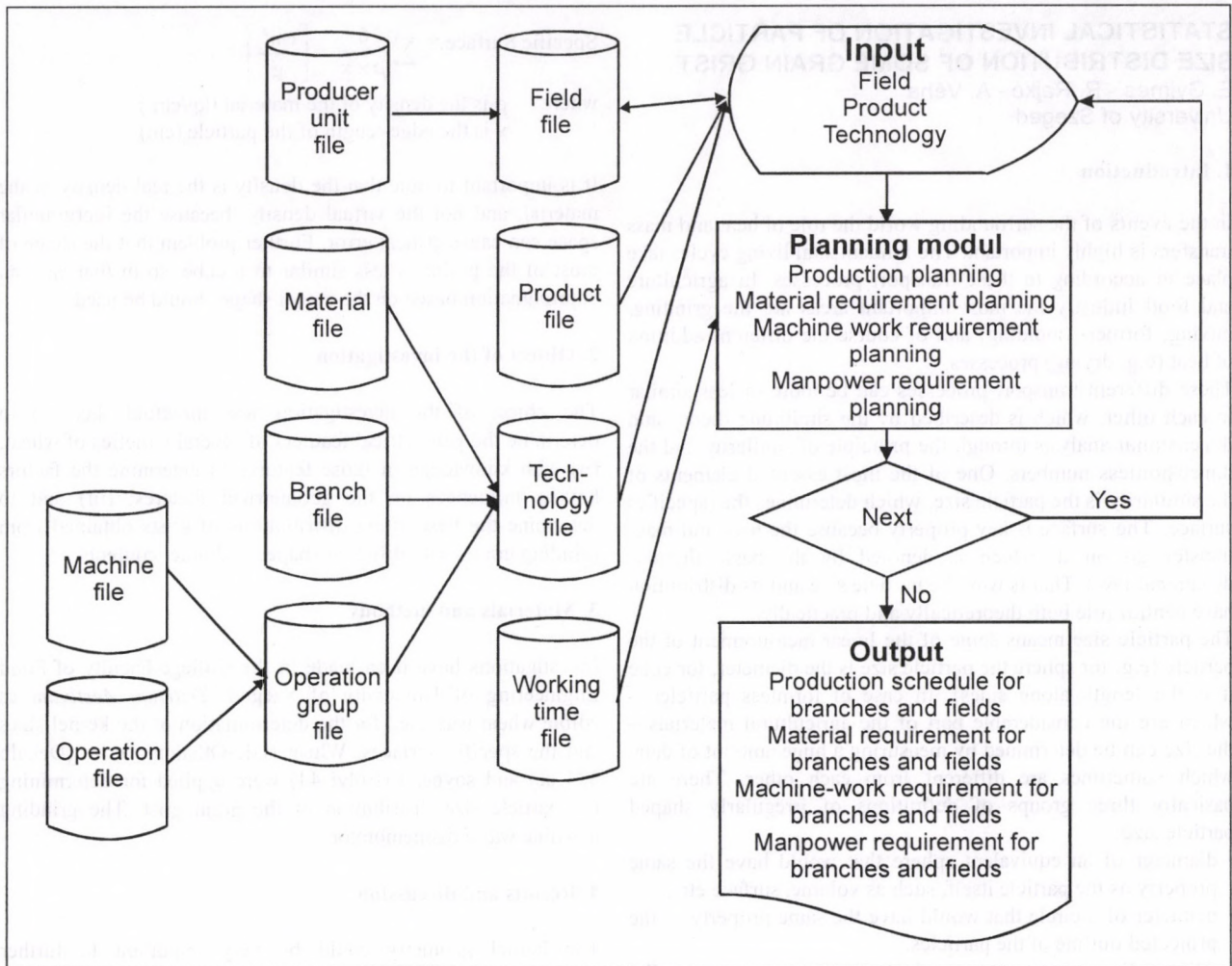

Figure 2 Scheme of the planning system

STATISTICAL INVESTIGATION OF PARTICLE SIZE DISTRIBUTION OF SOME GRAIN GRIST

E. Gyimes - R. Rajkó - A. Véha
University of Szeged

1. Introduction

In the events of the surrounding world the role of heat and mass transfers is highly important. The fundamental living cycles take place in according to these transport processes. In agriculture and food industry the most important areas are the grinding, mixing, former- (molding) and of course the different addition of heat (e.g. drying) processes.

These different transport processes can be more or less similar to each other, which is described by the similitude theory and dimensional analysis through the principle of similarity and the dimensionless numbers. One of the most essential elements of the similarity is the particle size, which determines the (specific) surface. The surface is key property because the heat and mass transfer go on it, which is denoted by the basic thermodynamical laws. That is why the particle size and its distribution have central role both theoretically and practically.

The particle size means some of the linear measurement of the particle (e.g. for sphere the particle size is the diameter, for cube it is the length along sides). In case of formless particles – which are the considerable part of the agricultural materials – the size can be determined by measuring a huge amount of data, which sometimes are different from each other. There are basically three groups of definitions of irregularly shaped particle size:

- diameter of an equivalent sphere that would have the same property as the particle itself, such as volume, surface etc.,
- diameter of a circle that would have the same property as the projected outline of the particles,
- a linear dimension, as measured, e.g., by a microscope parallel to a fixed direction.

The different measuring methods can give different values to the same "particle size", which can cause problems in some experiments and their reproduction. In the practice of granulometry the sieve analysis are frequently used. Two or more sieving should be performed with a suitable chosen screen set. In the USA the so called Tyler and ASTM, while in Europe

the Renard-type screen sets ($\frac{1}{5,10,20,40\sqrt{10}}$) are the standards. The

riddlings are measured and the three most important averages can be calculated: the mean, the median and the mode. The calculation is rendered more difficult by the spread of the distribution range, which is rather frequent in the investigation of the grain grist. There are several distribution types, among which in this paper we used the Gaudin-Andrejev-Schuhmann (GAS), the Rosin-Rammler-Sperling-Bennett (RRSB) and the lognormal alias Kolmogorov-Rényi (KR) distributions.

The determination of the (specific) surface is similarly problematic, because the surface is not continuous. For the calculation of specific surface from size distribution, several direct measurements have been developed: methods based on air permeability, gas-liquid adsorption, turbidimetry, laser granulometry, and gas diffusion. All of these methods suffer from the problem of dissolution, which extends the possibility of the error. And of course all methods can give different values for the same surface because of the different methodologies.

In the grinding experiments the simplified equation derived from the Rittinger's energy-size reduction law can be used for calculating specific surface value:

$$\text{Specific Surface} = \sum \frac{6}{\rho \times x} \left[\frac{\text{cm}^2}{\text{g}} \right]$$

where ρ is the density of the material (kg/cm^3)
 x is the edge-length of the particle (cm)

It is important to note that the density is the real density of the material, and not the virtual density, because the intergranular space can cause critical error. Further problem that the shape of most of the grains is less similar to a cube, so in that case an approximation based on the actual shape should be used.

2. Object of the investigation

The object of the investigation was threefold, i.e., (i) to determine the geometrical features of several varieties of wheat; (ii) with knowledge of those features to determine the factors having influences on the geometrical features; (iii) and to determine the best fitting distributions of grists obtained from grinding grains with different shapes and inner contents.

3. Materials and methods

Investigations have been made in the College Faculty of Food Engineering of University of Szeged. *Triticum Aestivum* as edible wheat was used for the determination of the kernel sizes and the specific surfaces. Wheat (GK-Öthalom), corn (Dekalb 524 sc) and soybean (Bolyi 44) were applied for determining the particle size distribution of the grain grist. The grinding machine was a dismembrator.

4. Results and discussion

The kernel geometry could be very important to further investigation, so we performed the determinations very accurately. The measurements were carried out by kernel after kernel. After the sample preparation 100-100 kernels were measured for the three geometrical sizes. Table 1 shows the results.

After that three grains of different sizes, properties and species were ground, and the distribution of grist was determined. The most well-known and used distribution types were studied, i.e., Gaudin-Andrejev-Schuhmann (GAS), the Rosin-Rammler-Sperling-Bennett (RRSB) and the lognormal alias Kolmogorov-Rényi (KR) distributions.

The equation of GAS:

$$\ln D\% = m(\ln x - \ln k)$$

where m is the slope,
 k is the modulus.

The equation of RRSB:

$$\ln \ln \frac{100}{R\%} = n(\ln x - \ln x_0)$$

where n is the slope (uniformity coefficient),
 x_0 is the modulus.

The equation of KR:

$$D(x) = \Phi \left(\frac{\ln x - \ln a - 3b^2}{b} \right)$$

where $\Phi(\cdot)$ is the standard normal distribution function,
 a, b are coefficients.

Table 1 Kernel geometrical sizes of the studied wheat varieties

| Varieties of wheat | Width | | Thickness | | Length | |
|---------------------|---------|-------|-----------|-------|---------|-------|
| | Average | SD | Average | SD | Average | SD |
| Durum 1998 | 2,976 | 0,164 | 2,912 | 0,144 | 6,501 | 0,257 |
| GK-Bétadur 1997 | 3,137 | 0,159 | 2,987 | 0,153 | 8,110 | 0,461 |
| GK-Csörnőc 1995 | 3,548 | 0,226 | 3,100 | 0,224 | 7,031 | 0,317 |
| GK-Csűrös 1997 | 3,593 | 0,162 | 2,903 | 0,137 | 6,329 | 0,286 |
| GK-Csűrös 1998 | 3,329 | 0,164 | 2,832 | 0,123 | 6,755 | 0,256 |
| GK-Duna 1996 | 3,231 | 0,184 | 2,886 | 0,165 | 6,455 | 0,307 |
| GK-Duna 1998 | 2,945 | 0,153 | 2,887 | 0,125 | 6,466 | 0,293 |
| GK-Kata 1995 | 3,552 | 0,162 | 2,953 | 0,156 | 6,271 | 0,216 |
| GK-Kata 1997 | 3,545 | 0,191 | 2,917 | 0,157 | 6,374 | 0,230 |
| GK-Kata 1998 | 3,218 | 0,184 | 2,692 | 0,158 | 6,046 | 0,234 |
| GK-Öthalom 1995 | 3,429 | 0,152 | 3,001 | 0,187 | 6,503 | 0,338 |
| GK-Öthalom 1997 | 3,408 | 0,242 | 3,102 | 0,173 | 6,469 | 0,279 |
| GK-Öthalom 1998 | 3,209 | 0,207 | 2,916 | 0,176 | 6,730 | 0,293 |
| GK-Pinka 1995 | 3,525 | 0,220 | 2,923 | 0,184 | 7,010 | 0,389 |
| Jubilejnaja-50 1996 | 3,360 | 0,154 | 2,932 | 0,115 | 6,954 | 0,320 |
| Tambor (A) 1998 | 3,304 | 0,242 | 2,916 | 0,206 | 6,222 | 0,362 |

Excluded the detailed measurement data and the calculations Table 2 shows the linearized equations and the determination coefficients. The determination coefficient indicates the strength of the connection between the measured and calculated values. Studying the table asserts that the best-fitted distribution is the KR based on R² (see Fig1.).

Acknowledgements

We would like to thank the Wheat Management of Cereal Research Non-Profit Company, Szeged for providing wheat samples. We would also like to thank Dr. János Matuz and Prof. Miklós Neményi for their help and support. This research was supported by the *Hungarian Science Foundation* under contract numbers OTKA F029631 (EGy), OTKA T035125 (RR) and OTKA T03009 (AV).

References

- [1.] BEKE B. (1964) *Aprításelmélet*, Akadémiai Kiadó, Budapest.
- [2.] BEKE B. (1981) *"The Process of Fine Grinding"*, Akadémiai Kiadó, Budapest.
- [3.] FAYED M. E. AND OTTEN L. (1984) *"Handbook of Powder Science and Technology"*, Van Nostrand, New York
- [4.] RAJKÓ R. (1994) "Lineáris és linearizált függvénykapcsolatok kiértékelése", *Élelmiszeripari Főiskola, Tudományos Közlemények*, Vol. 17, 44-52.
- [5.] RAJKÓ R. and SZABÓ G. (1995) "Linearizált függvénykapcsolatok kiértékelése az aprítás és szűrés műveletekre vonatkozóan", *Élelmiszeripari Főiskola, Tudományos Közlemények*, Vol. 18, 9-18
- [6.] RAJKÓ R., HORVÁTH T., SZABÓ ZS., HORVÁTH N. (2001) "Aprítási művelet kemometriai szemléletű optimalizálása", *Műszaki Kémiai Napok'01 (Veszprém) Konferencia Kiadvány* 37-42.

Table 2 The three different types of distribution equation and its determination coefficients

| Species | RRSB | | GAS | | KR | |
|---------|------------------|----------------|------------------|----------------|-----------------|----------------|
| | Equation | R ² | Equation | R ² | Equation | R ² |
| Wheat | Y=2,7514x+1,2211 | 0,9304 | Y=2,7322x+0,6404 | 0,7955 | Y=1,715x+1,2635 | 0,9711 |
| Corn | Y=3,1791x+1,4446 | 0,8708 | Y=2,3836x+0,4846 | 0,8755 | Y=1,906x+1,3445 | 0,9740 |
| Soybean | Y=2,9181x+1,3841 | 0,8934 | Y=2,5328+0,6135 | 0,8284 | Y=1,648x+1,1682 | 0,9754 |

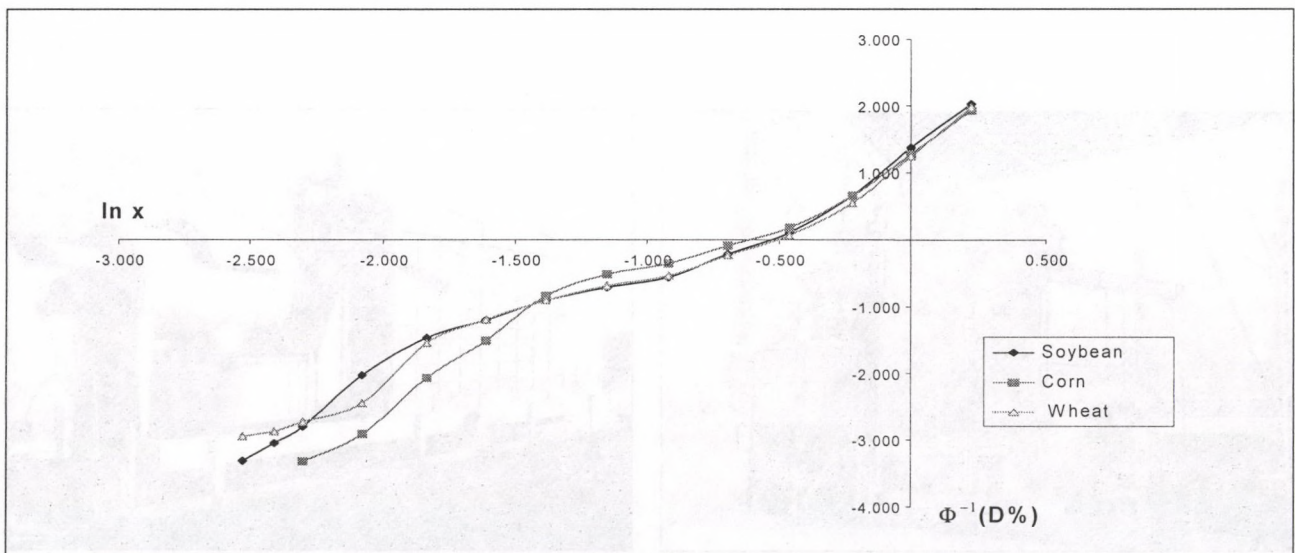

Figure 1 Kolmogorov-Rényi's lognormal particle size distribution

ANALYSING OF THE CORN DRYING PROCESS

J. Csermely - M. Herdovics

Hungarian Institute of Agricultural Engineering

Summary

During operation tests heat and material transport processes were determined and fairly accurate mathematical relationships were elaborated to describe the drying characteristics of corn as well as the changes of seed temperature and density.

Aims of the research

Aims of the research were the determination of the processes of heat and material transport of the widely used grain drying systems and analysing and comparison of the drying processes of the traditional thin layer driers with cross-flow system (B1-15) and the thick layer driers with intermittent operation and material circulating system (MECMAR; STELA-MUF)

Material and method

Examinations were carried out under operative conditions. Moisture content of corn varied between 21.3-29.5 %. Types of driers were MECMAR 34/90 and STELA-MUF 70/2 of intermittent running thick layer and material circulating systems. Type of measuring instrument was ALMEMO-5590 heat and airtechnical measuring and data logging system.

Results

Test results and measuring connections of corn drying at different type of driers are shown on Fig. 3; 4; 5; 6; 7.

Drying process can be seen on Fig. 3. While characteristics of the drying speed on Fig. 4. Changing of bulk density of corn are shown on Fig. 5 and Fig. 6. On Fig. 7 laboratory and operational measurings are presented plotted against the moisture content. It serves for verification that maximum value of the bulk density can be measured near the equilibrium moisture content.

Evaluation of results and conclusions

During the tests of heat and material transport of grain drying it has been found as follows.

- Drying process of corn in the range of the examined moisture content (29.5 → 12.0 %) can be described by exponential functions (see on Fig.3.) fairly accurately.
- Velocity of drying was 3.00-3.10 moisture %/h in the case of thin layer continuous running and cross-flow system and 2.10-2.20 moisture %/h in the case of thick layer intermittent running and recirculating type of driers at 110 °C pre-setted material temperature. (Fig.4)
- Raising of seed temperature of corn can be described well by a quadratic polynome and in the test conditions did not reach the 50 °C that meant a quality drying.
- Owing to the contraction of corn and the abstraction of moisture content density of corn increased by 10.5-12.5 % during the drying process. Quadratic equation that described the process had a maximum value around 720 kg/m³ of density, close to the equilibrium moisture content of 14.0-15.5 %. In the case of over-drying, between 12.0-13.8 % water content, density decreased to about 710 kg/m³. (Fig. 5, 6)

For verifying this theory examinations were carried out with different kind of hybrids in exsiccator. Corn seed with original moisture content of 12-14 % and density of 700-740 kg/m³ were dried under the constant moisture content to 0.04-3.60 % value. In this case density decreased to 669-696 kg/m³ while the inner structure of corn was lost. (Fig. 7)

It is worth examining the diagram of changing of the drying speed in detail (Fig.4) According to the classical theory the speed curve has three stages that differ well from each other. These stages are the steep elevation, the equalilibrium condition and the decreasing tendency. In this case all the three curves have maximum values while the stage of constant speed cannot be shown. Our intention is to prove this theory by further investigations.

References

- [1.] CSERMELY J. - HERDOVICS M.: Gabonaszárítási rendszerek műszaki és környezettechnikai összefüggései. MTA-AMB Kutatási és Fejlesztési Tanácskozás, Gödöllő, 2000. 2. kötet. 91-94 p.
- [2.] BEKE J.: Terményszárítás. Agroinform Budapest, 1997.
- [3.] BEKE J.: A szemeskukorica-szárítás folyamatának elemzése. Akadémiai Kiadó 1999.
- [4.] KOVÁCS J. - NEMÉNYI M.: Moisture gradient vector calculation as a new method for evaluating NMR images of corn (Zea Mays L.) kernels during drying. ELSEVIER, 1999 Vol.
- [5.] PROF. DR. J. CSERMELY - DR.M.HERDOVICS.: Connections of grain drying processes. HAE 13/2000, pp 17-19.

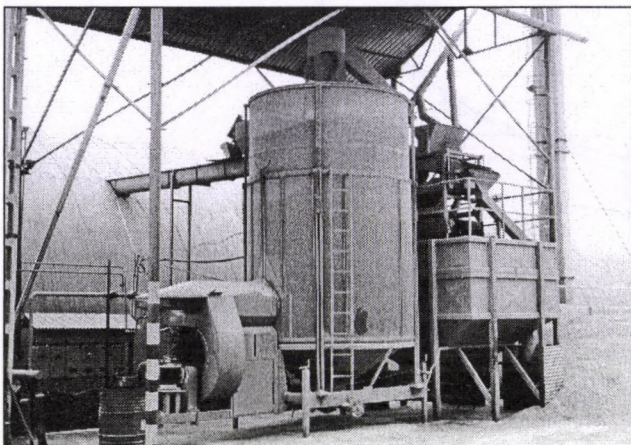

Figure 1 Mecmar-34/90 dryer

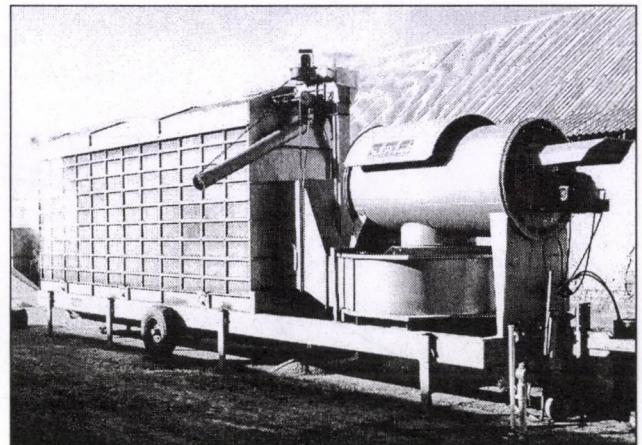

Figure 2 Stela MUF 70/2 dryer

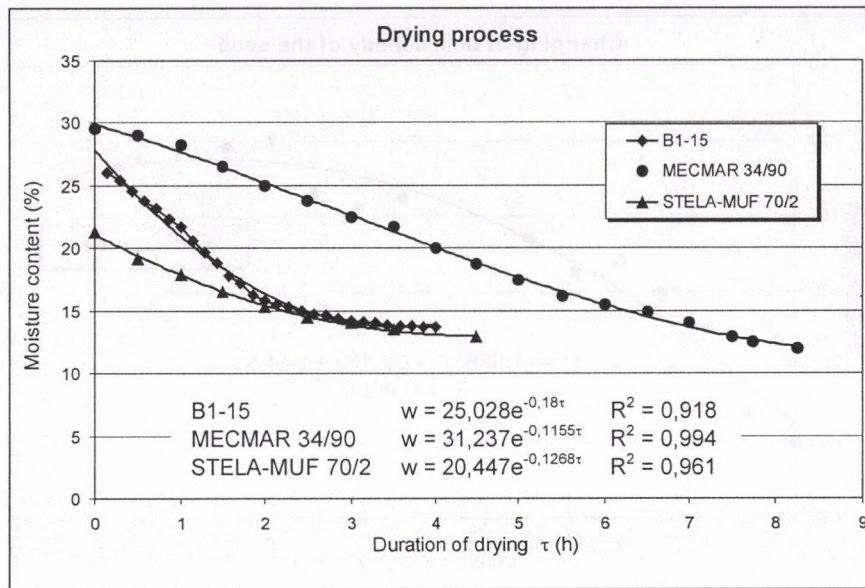

Figure 3

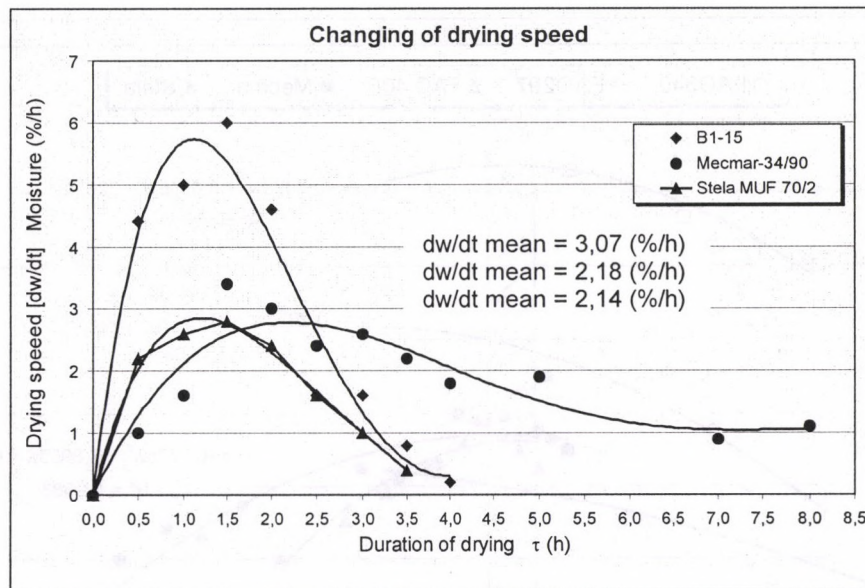

Figure 4

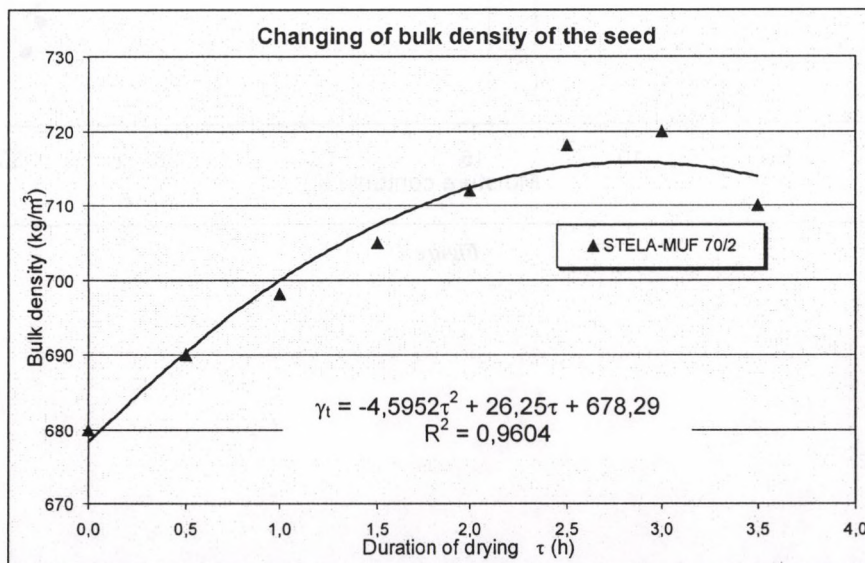

Figure 5

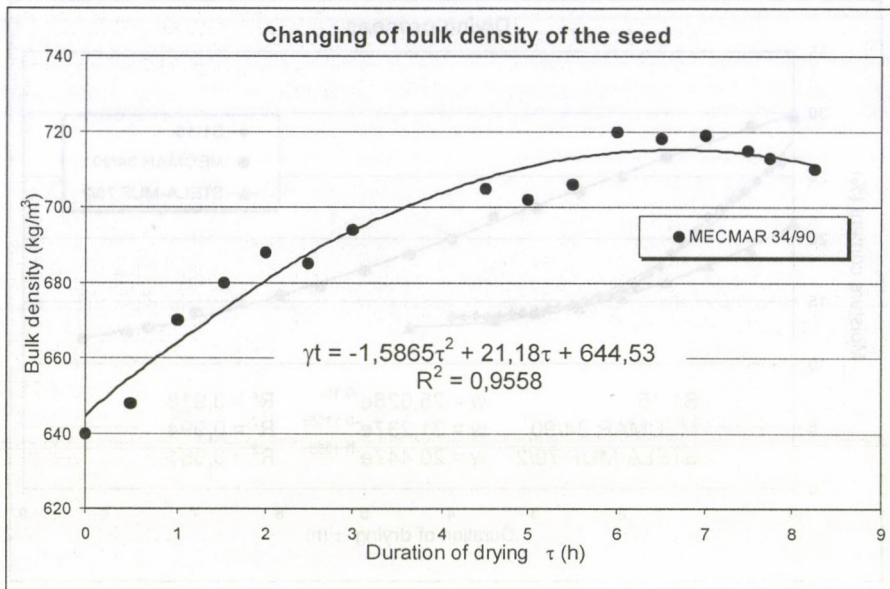

Figure 6

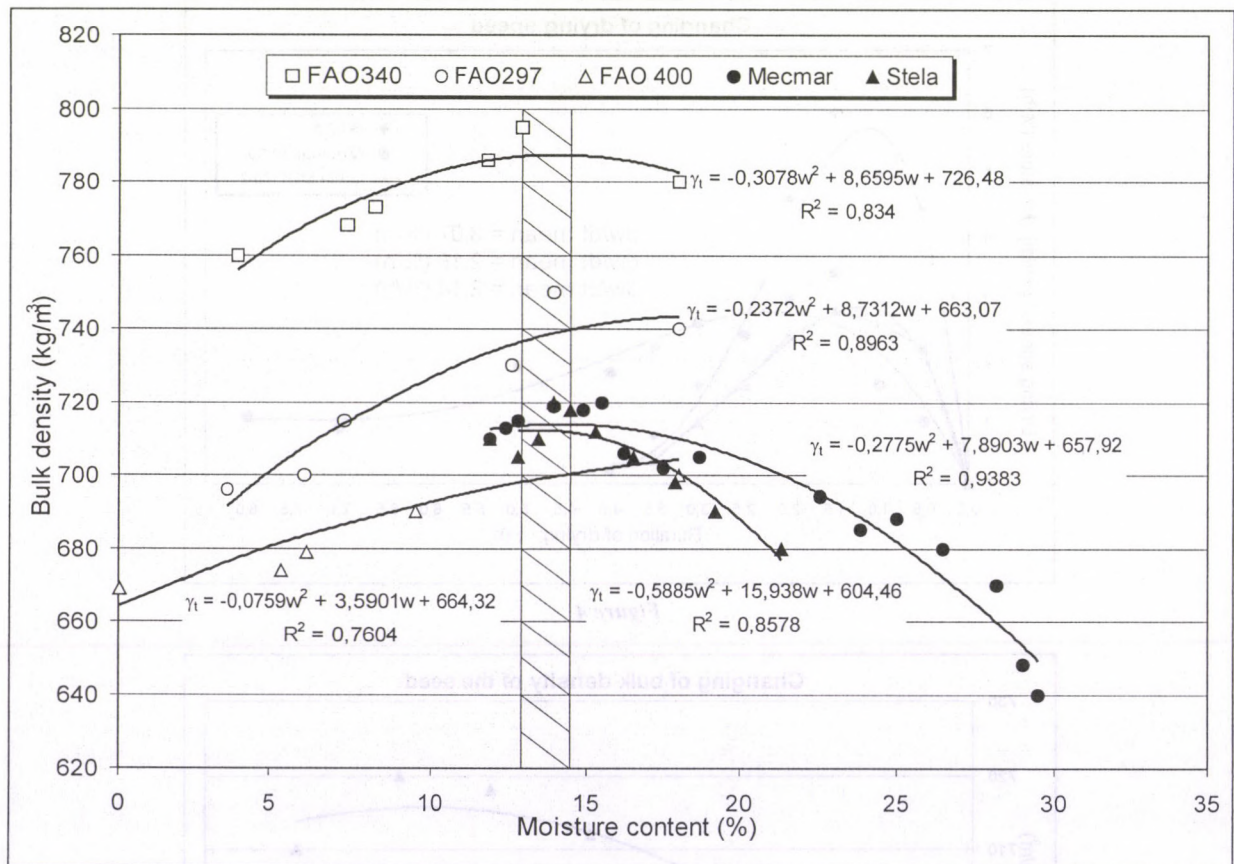

Figure 7

DETERMINATION OF INNER VISCOSITY OF V-BELT BY BENDING TEST

L. Kátai - P. Szendrő - Gy. Vincze - I. Szabó
Szent István University, Gödöllő

1. Introduction

The required lifetime and proper operation of V-belt drive can be assured by fulfilment of requirements during the drive design and operation. One of the determining and critical factors of lifetime is the developing temperature in the belt. The value of this temperature is determined by the operation circumstances for example slip, loading, external effect, and the construction such as V-belt cross-section, sheave diameter, belt frequency, etc.

The objective of the test is to determine the inner viscosity of the belt - which characterizes of its hysteresis loss - by bending the V-belt on specific test equipment.

2. Viscoelastic model of the V-BELT

One of the producing factors of thermal loading of V-belts is the hysteresis loss during the bending load, which is originated from the inner viscosity. The V-belt, as a viscoelastic linear model can be characterised according to Figure 1.

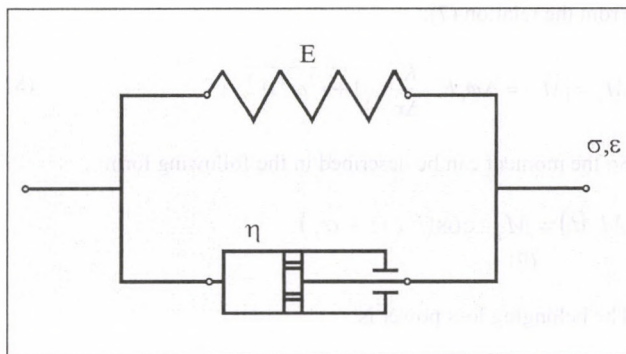

Figure 1 Mechanical model of V-belt

Equation of model in Figure 1:

$$\sigma = E \cdot \varepsilon + \eta \frac{d\varepsilon}{dt} \quad (1)$$

For more simple description, let us introduce the $\frac{d}{dt} = s$ operator,

$$\sigma = E \cdot (1 + s \cdot \eta) \cdot \varepsilon = E(s) \cdot \varepsilon, \quad (2)$$

where,

$$- E(s) = E(1 + s \cdot \eta) - \text{Young's modulus operator and } \eta = \frac{\eta}{E}$$

Bending of a Δx length V-belt can be explained according to Figure 2:

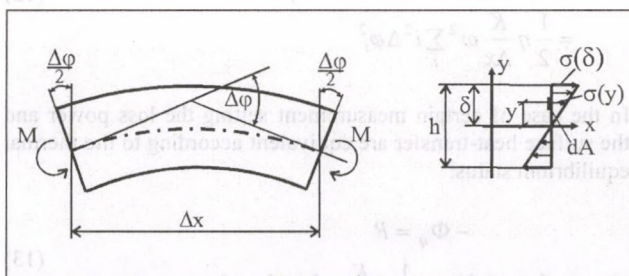

Figure 2 Explanation of bending load of V-belt piece

Let us suppose that the stress and the elongation have linear function, the bending moment can be written by the following classical interpretation:

$$M = \int_A \sigma(y) \cdot y dA = \frac{\sigma(\delta)}{\delta} \int_A y^2 dA = \frac{\sigma(\delta)}{\delta} \cdot K, \quad (3)$$

where:

- A - is the area of V-belt cross-section [mm²];
- K - is the section modulus of V-belt [mm³].

From the above equations, the bending moment can be written in the following form:

$$M = \left[E(s) \cdot \frac{K}{\Delta x} \right] \cdot \Delta \varphi. \quad (4)$$

This means that the V-belt can be interpreted as a mechanical impedance, where moment M creates „current” equivalent to $\Delta \varphi$ angular displacement, according to Figure 3:

$$\bar{Z}(s) = E(s) \cdot \frac{K}{\Delta x}. \quad (5)$$

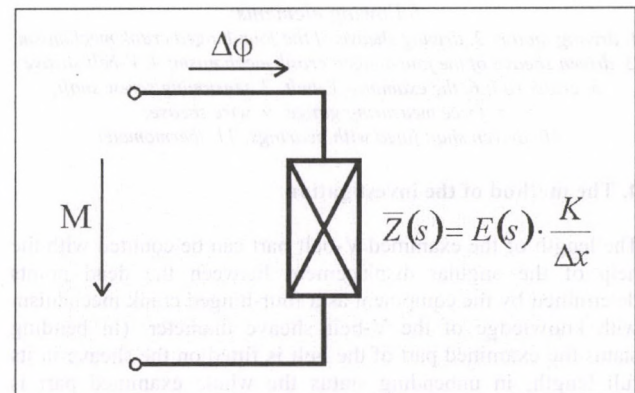

Figure 3 Interpreting V-belt as a mechanical impedance

3. The structure of the TEST equipment

The bending of the V-belt was performed on self-planned and self-made test equipment. The examined piece of V-belt was endessed with the help of a steel wire. To eliminate the effect of the slip the V-belt was fastened with the help of a radial screw placed in the sheave. According to the above the endessed drive could be pre-tensioned with screw tension mechanism by the fastening of wire sheave round the balance point. With the help of the four-hinged crank mechanism the equipment was generate an alternate motion on the driven shaft, in accordance with it the tensioned V-belt is bended to the sheave in the first period of the motion then in opposed motion the V-belt is straightened again. With this motion the deformation resulted in real drive of the V-belt can be modelled and the temperature increasing followed by bending effect is measurable.

The structure of the test equipment makes the changing of several parameters possible. A frequency regulator can set in the revolutions per minute of the driving motor so the bending frequency of the V-belt is changeable. With the change of the V-belt sheave placed at the end of the driven shaft the sheave diameter applied in the test can be changed. And with the above-mentioned screw shaft the pre-tension that is to say the tensioning force can be changed.

A non-contact infrared thermometer measured the temperature. The type of Impac IN 3000 thermometer is used in 0-120 °C measuring range with 0,1 °C accuracy.

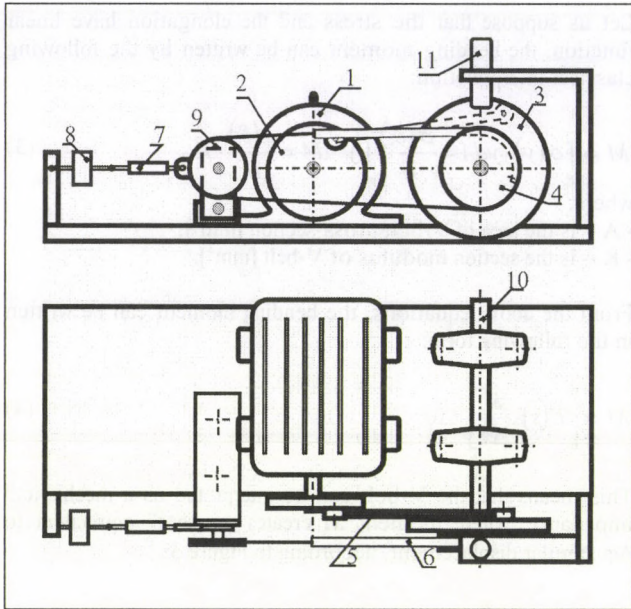

Figure 4 Scheme of the test equipment

According to the scheme the equipment consists of the following elements:

1. driving motor;
2. driving sheave of the four-hinged crank mechanism;
3. driven sheave of the four-hinged crank mechanism;
4. V-belt sheave;
5. crank rod;
6. the examined V-belt;
7. tensioning screw shaft;
8. force measuring gauge;
9. wire sheave;
10. driven shaft fitted with bearings;
11. thermometer.

4. The method of the investigation

The length of the examined V-belt part can be counted with the help of the angular displacement between the dead points determined by the equipment as a four-hinged crank mechanism with knowledge of the V-belt sheave diameter. (In bending status the examined part of the belt is fitted on the sheave in its full length, in unbending status the whole examined part is straight). The angular displacement between dead points can be determined with construction (Figure 5).

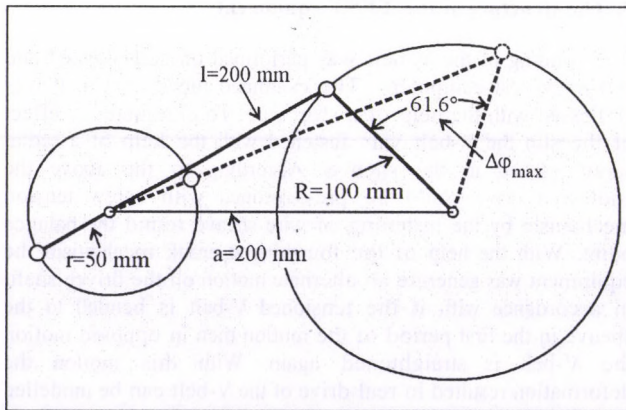

Figure 5 The determination of angular displacement between dead points with construction on the driven shaft

The motion of the V-belt part described with Δx length consists of the following parts: 1. bending in the sheave 2. bending out the sheave.

According to the above-mentioned determinations the repeated bending of the belt part so the changing of the $\Delta\phi$ angle is happening according to Figure 6.

If we put the $\Delta\phi$ datum line in the centre, we will get an even function. In this way while writing the function into Fourier series we can calculate on cosine members, so:

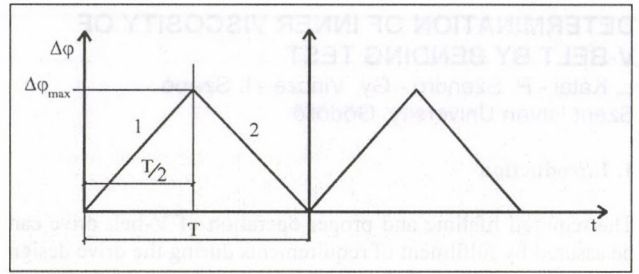

Figure 6 Changing of the $\Delta\phi$ angle plotted against time

$$\Delta\phi(t) = \Delta\phi_0 + \sum_i \Delta\phi_i \cdot \cos i \frac{2\pi}{T} t = \Delta\phi_0 + \sum_i \Delta\phi_i \cdot \cos i \cdot \omega t \quad (6)$$

where,

- $\Delta\phi_i$ - is a Fourier co-efficient.

The complex amplitude of the moment belongs to each angular amplitude is counted in the following form:

$$\bar{M}_i = \Delta\phi_i \cdot E(1 + j i \omega \eta') \cdot \frac{K}{\Delta x} \quad (7)$$

where,

- j - is the imaginary unit.

From the relation (7):

$$M_i = |\bar{M}_i| = \Delta\phi_i E \cdot \frac{K}{\Delta x} \cdot \sqrt{1 + i^2 \omega^2 \eta'^2} \quad (8)$$

So the moment can be described in the following form:

$$M_i(t) = M_i \cdot \cos(i \cdot \omega t + \alpha_i) \quad (9)$$

The belonging loss power is:

$$P_i = \frac{1}{T} \int_0^T M_i(t) \frac{d}{dt} [\Delta\phi_i \cos i \cdot \omega t] dt \quad (10)$$

$$\begin{aligned} P_i &= \frac{1}{2} M_i i \omega \cdot \Delta\phi_i \sin \alpha_i = \frac{1}{2} (\Delta\phi_i)^2 \cdot \\ &\cdot E \frac{K}{\Delta x} \sqrt{1 + i^2 \omega^2 \eta'^2} (i \omega) \frac{i \omega \eta'}{\sqrt{1 + i^2 \omega^2 \eta'^2}} = \\ &= \frac{1}{2} (\Delta\phi_i)^2 \cdot E \frac{K}{\Delta x} (i^2 \omega^2) \eta' \end{aligned} \quad (11)$$

Applying this for all co-efficient we get the resultant loss power:

$$\begin{aligned} P &= \sum_i = \frac{1}{2} E \frac{K}{\Delta x} \omega^2 \eta' \sum_i i^2 \Delta\phi_i^2 = \\ &= \frac{1}{2} \eta \frac{K}{\Delta x} \omega^2 \sum_i i^2 \Delta\phi_i^2 \end{aligned} \quad (12)$$

In the case of certain measurement setting the loss power and the surface heat-transfer are equivalent according to the thermal equilibrium status:

$$\begin{aligned} -\Phi_q &= P \\ \alpha \cdot K_{ker} (T - T_k) \Delta x &= \frac{1}{2} \eta \frac{K}{\Delta x} \omega^2 \sum_i i^2 \Delta\phi_i^2 \end{aligned} \quad (13)$$

where:

- Φ_q – is the surface heat-transfer [J/s];
- P - inner loss power [W].
- α - surface heat-transfer factor [W/m²K];
- K_{ker} – perimeter of the V-belt [m];
- T – temperature of the V-belt [K];
- T_k – ambient temperature [K].

If the heat transfer is constant we can determinate the inner co-efficient of friction (η) from relation 13 which describes the inner loss originates from V-belt bending.

5. Calculation of inner co-efficient of friction

With the help of bending measurement results and relation 13, the examined V-belt's inner co-efficient of friction can be determined. With knowledge of it for the certain V-belt cross section construction loss power can be counted even in operation circumstances different from the investigation.

We can determine the co-efficients of Fourier series (6) are written on $\Delta\varphi(t)$ function (Figure 6), which describes bending, on the following way:

$$\Delta\varphi_i = \frac{4}{T} \cdot \frac{c}{\left(\frac{2\pi}{T} \cdot i\right)^2} \cdot (\cos i \cdot \pi - 1), \quad (14)$$

where,

- c – is the incline of forced function, $c = \frac{2 \cdot \Delta\varphi_{\max}}{T}$;
- T – is the period time [s];
- i – is the number of Fourier series co-efficients.

We determined the first seven co-efficient values for the belt frequency values. With determining seven members the function has showed a really good fit. The inner co-efficient of friction can be determined with the data of measuring series doing with $d_p=80$ mm sheave diameter. The frequency values were set in the measuring series are the followings:

$$f_1=160 \text{ min}^{-1}; f_2=200 \text{ min}^{-1}; f_3=240 \text{ min}^{-1}; f_4=290 \text{ min}^{-1}.$$

From relation (13) and (14), the inner co-efficient of friction can be expressed in the following form:

$$\eta = \frac{2 \cdot \alpha \cdot K_{ker} (T - T_k) \Delta x}{\frac{K}{\Delta x} \omega^2 \sum_{i=1}^7 i^2 \left[\frac{4}{T} \cdot \frac{c}{\left(\frac{2\pi}{T} \cdot i\right)^2} (\cos i \pi - 1) \right]} \quad (15)$$

The inner co-efficient of friction of the examined V-belt construction is the value of $\eta=410 \text{ Ns/m}^2$.

Summary

In terms of temperature conditions the hysteresis loss during bending the V-belt to the sheave has significant importance. For measuring the temperature increasing originates from bending we made test equipment that generates an alternate motion. The above-mentioned temperature is measurable and to eliminate the effect of the slip the V-belt was fastened in the sheave. The test equipment can be applied for R&D because the different cross section constructions can be examined by a new standpoint.

During bending measurements with the help of the V-belt's viscoelastic model and with determining the $\Delta\varphi(t)$ central angle, which describes bending, the inner co-efficient of friction can be counted in thermal equilibrium status. The results can complete the drive design process and each cross section constructions become comparable with each other in terms of their bending behaviour.

References

- [1.] M. CSIZMADIA B. - NÁDORI E.: Strength of Material. National Coursebook Publisher, Budapest, 1999.
- [2.] KÁTAI L.: Questions of Life-time Increasing of V-belts Applied on Harvesting Machines. Phd dissertation, Gödöllő, 2001.
- [3.] PONOMARJOV SZ.D.: Strength Calculation in Engineering 7. Technical Publisher, Budapest, 1966.
- [4.] SZENDRŐ P.: Machine Elements III. Gödöllő University of Agricultural Sciences, 1980.

UP-TO-DATE TECHNOLOGIES OF GRAIN STORAGE

Gy. Komka
Hungarian Institute of Agricultural Engineering

Summary

The international and national trends show the increase in rate and frequency of deterioration of stored feed raw material. One of the influencing parameters is the storing technology, because nowadays the storing capacity of Hungary mostly not adequate or not provides adequate conditions for safety storing. Investigation of mechanization and feed quality can show the usability of the following technology:

- storage of cereals containing balanced moisture in controlled air-condition of barn,
- storage of cereals containing 16-18 % moisture in barn equipped with automated ventilation system,
- storage of cereals containing 16-18 % or balanced moisture treated with fluid preservatives

1. Introduction

Aim of the research project was to investigate the mechanical and feed quality parameters of different up-to-date storing technologies. Within the research project investigation of storing technology of controlled ventilation system and treatment with fluid preservatives were carried out in the case of feeds with balanced moisture content. Furthermore the author investigated the automated ventilation system and grains treated fluid preservatives in the case of cereals with 16-18 % moisture content.

2. Material and Method

The investigation of corn harvested and stored in 1999, with balanced moisture content and in controlled air-condition was executed in a barn with 2 x 5000 tons capacity of Mesztesyő TIG farm.

The measurement of automated ventilation system was carried out in corn loaded in 1999 into a DV-T type barn with contribution of Bácsalmás Agricultural Corporation. The barley containing balanced moisture content was treated Luprosil NC-64, while corn with 16-18 % moisture content was treated with Lupro-Grain fluid preservative. The measurement was executed with contribution of Nak-i Cooperation. Determination of nutrient content and microbial status was carried out in OMMI (National Agricultural Certification Qualifying centre laboratory).

In the case of ventilation system the author investigated the air-technical parameters (t , φ), constancy of air-speed flowing through the yield, the air-speed in different point of barn, power and electrical parameters of technological equipments.

In the case of treatment with fluid preservatives the cereals stored during 3, 6 and 9 month were treated with different amount of preservative and the temperature of the cereals was controlled. Sampling was carried out in stated intervals (1-2 month) from cereals stored in different duration and the samples were measured in lab.

The laboratory investigations included moisture and nutrient content, acid- and peroxid status, furthermore at microbiological determination the number of mould and composition of mouldflora were measured.

3. Result of research

The results of investigation on storing technology and feed quality at different storing methods can be summarized in the followings.

3.1. Storing technology of controlled air-conditional cereal containing balanced moisture

The essence of this technology is that at certain temperature or humidity of the air above the cereal yield the ventilation system turns on and airing the airspace.

The MC-01 type control system executes the ventilation of barn according to preset values observed by sensors equipped in the barn for temperature and humidity measurement.

The changes of temperature and moisture content of the grain, the temperature of the air, the air-speed during ventilation directly above the yield, 2 meter above and at airing tube were measured during the storing period. Moreover the author had the microbial status of corn samples investigated by the lab.

The two ventilators provide 11.500 m³/h air for airing. At storing of cereals containing relative low moisture content the ventilation is important especially during winter, when it prevents the forming of condensation water in the uninsulated roof therefore prevents the moisturising of yield surface.

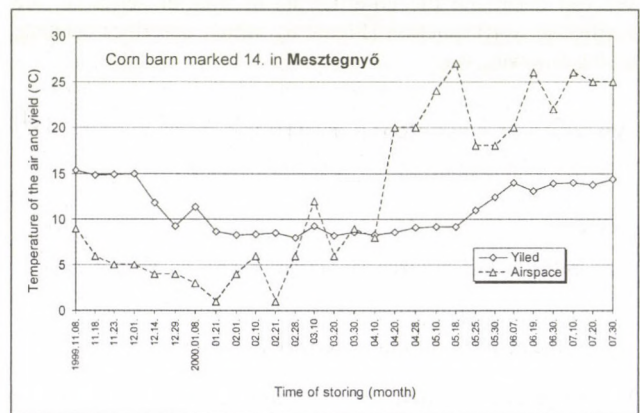

Figure 1 Changes of temperature in yield and air depending on duration of storing

3.2. Storing technology of cereals with 16-18% moisture content in barn equipped with automated ventilation system

The automated ventilation system was installed into a DV-T type barn. (2nd figure).

The task of the control system is: receiving the data from the equipped 36 temperature internal sensors, data from sensors measuring external temperature and relative humidity, processing of data, opening and closing the ventilation-canals depending on the evaluated results.

The control system can be operated automatically or manually. At automatic operating the control system measures cyclicly the external temperature which is shown on the screen. It saves the 5 highest temperature value and connecting number of ventilation canal from the 18 temperature pairs observed above the ventilation canals during the measuring period. At the end of the measuring cycle the system evaluates the measured parameters and decides about opening and closing of the canals according to the followings:

- Opens the canals belongs to the 5 highest temperature value and turns on the ventilator, if:

$$\begin{aligned} t_{\text{grain}} &< t_{\text{upper limit}} \\ t_{\text{external}} &< t_{\text{grain}} - 2^{\circ}\text{C} \\ \varphi_{\text{external}} &> \varphi_{\text{preset}} \end{aligned}$$

- Opens the canals belongs to the 3 highest temperature value and turns on the ventilator, if:

$$\begin{aligned} t_{\text{lower limit}} &< t_{\text{grain}} < t_{\text{upper limit}} \\ t_{\text{external}} &< t_{\text{grain}} - 5^{\circ}\text{C} \\ \varphi_{\text{external}} &> \varphi_{\text{preset}} \end{aligned}$$

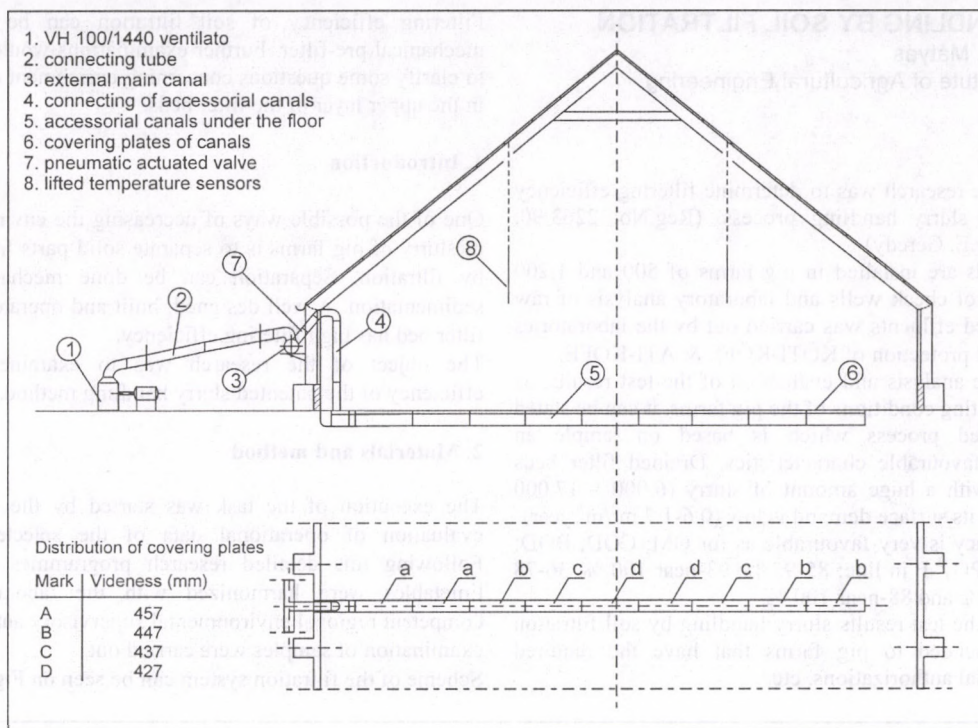

Figure 2 Accommodation of ventilation system in DV-T barn

– Does not open the canals and does not turn on the ventilator, if:

$$\begin{aligned}
 t_{\text{external}} + 2 \text{ C} &> t_{\text{grain}} \\
 t_{\text{grain}} &< t_{\text{lower limit}} \\
 t_{\text{external}} &< t_{\text{lower limit}} \\
 t_{\text{external}} &< 1 \text{ C} \\
 \varphi_{\text{external}} &> \varphi_{\text{preset}}
 \end{aligned}$$

The preset values can be changed, recommended values are the followings: $t_{\text{upper limit}} = 25 \text{ C}$, $t_{\text{lower limit}} = 18 \text{ C}$ and $\varphi_{\text{preset}} = 60 \%$. According the measurement of the author in the case of 5 open canals the ventilation is $20.5 \text{ m}^3/\text{h/t}$, while at 3 open canals the value is $33.3 \text{ m}^3/\text{h/t}$, which is suitable for condition-saving and reducing the temperature of the grain by some Celsius degree. The form of canal-system provides adequate constant ventilation, distribution of temperature values related to the whole barn is within the range of $3\text{-}4 \text{ }^\circ\text{C}$. The temperature of corn loaded in 1999 and containing $12\text{-}15.5 \%$ moisture content did not exceed the the preset upper limit after 36.5 hour ventilation. The relative energy consumption of the ventilation and its cost was 0.2 kWh/t and 4.7 Ft/t , separately.

3.3. Storing technologies of cereals containing 16-18 % or balanced moisture treated with fluid preservatives

In the case of barn without ventilation system, the chemical treatment of cereals with effective fungicides before loading can be applied successfully for saving the good quality of feedstuffs. The fungicides appeared in several form in Hungary. The main component is the propionic acid, amount of it depends on the moisture content of the cereal and the required duration of the storage. The fluid fungicide has to be spread homogenously onto the surface of the grain. Different equipments for this operation is already available.

In the case of barley containing $11\text{-}12 \%$ moisture, Luprosil NC 64 preservative (produced by BASF) was applied. For preservation of corn containing $16\text{-}18 \%$ moisture, Lupro Grain preservative was used. J-100, DJ-1000 and DJ-2000 type equipment of NTR Ltd. (Komló) was applied for fluid-pumping. The author payed particular attention for investigation of the effect on grain-quality (especially mould-inhibition).

4. Conclusions and recommendations

The air-ventilation technology can be used for long-term storing of cereals containing balanced moisture with advantageous parameters of grain-quality.

Fast and well equipped receiving of grain yield, moreover regular control of the grain (moisture content, temperature, insect-infection) have important role in this technology.

Applying of propionic acid provides suitable results in the case of above mentioned technology. The amount of preservative depending on duration of storage can prevent the disadvantageous mould infection in stored grain. This technology can be used especially when there is no facility for other treatments to save the stored cereal.

Treatments with preservatives of cereals containing $16\text{-}18 \%$ moisture prevent getting warm of the yield and reduce proliferation of field-and storehouse-mould.

Different pumping equipments satisfying requirements of different farm-size and different preservatives are available in Hungary. The advantageous results of BASF Luprosil NC-64 and Lupro-Grain were proved by the author's investigations.

The treatment of cereals with preservatives is recommended to feedtufts not for sale.

The relative cost of treatment depending on moisture content of cereals and duration of storage is: $1500\text{-}2600 \text{ Ft/tons}$.

The barn equipped with automated ventilation and under-floor canal-system is recommended (according to the results) for long-term storage of cereals containing $16\text{-}18 \%$ moisture.

The above mentioned system does not obstruct mobile loading machines, and saves automatically the suitable conditions in grain yield depending on external temperature and relative humidity (reduction of temperature) where it is necessary.

The automated control system prevents mistakes caused by human subjectivity during operation of the technology.

In the case of each investigated technology owing to the applied condition-saving methods the microbial status of the cereals was under the authorised limit: number of mould was under $5 \times 10^4 \text{ CFU/g}$, while potentially toxin-producer genus was observed under $5 \times 10^3 \text{ CFU/g}$ of authorised limit.

SLURRY HANDLING BY SOIL FILTRATION

L. Fenyvesi - L. Mátyás

Hungarian Institute of Agricultural Engineering

Summary

The object of the research was to determine filtering efficiency of the patented slurry handling process. (Reg.No: 2263/90. Patent owner: Dr.E. Geredy)

Tested filter beds are installed in pig farms of 500 and 1,200 sows. Sampling of check wells and laboratory analysis of raw slurry and filtered effluents was carried out by the laboratories of environmental protection of KÖTI-KÖFE & ATI-KÖFE.

According to the analysis and evaluation of the test results, as well as the operating conditions of the pig farms, it can be stated that the patented process which is based on simple an earthwork, has favourable characteristics. Drained filter beds can be loaded with a huge amount of slurry (6,000 – 17,000 m³/ha,year), and its surface demand is low (0.6-1.7 m²/m³,year). Filtering efficiency is very favourable as for OM; COD; BOD; NO₃⁻; NH₄⁺-N; PO₄³⁻-P in line: 85-95 %; 93-near 100 %; 36-78 %; 53-near 100 %; and 88-near 100 %.

On the basis of the test results slurry handling by soil filtration can be recommended to pig farms that have the required conditions, official authorizations, etc.

Filtering efficiency of soil filtration can be improved by mechanical pre-filter. Further examinations would be necessary to clarify some questions concerning enrichment of components in the upper layer of the filter beds.

1. Introduction

One of the possible ways of decreasing the environmental load of slurry of pig farms is to separate solid parts from liquid part by filtration. Separation can be done mechanically or by sedimentation. A well designed, built and operated drained soil filter bed has high filtering efficiency.

The object of the research was to examine the filtering efficiency of the patented slurry handling method.

2. Materials and method

The execution of the task was started by the collection and evaluation of operational data of the selected pig farms. Following this detailed research programmes and sampling timetables were harmonized with the laboratories of the competent regional environmental supervisory authorities where examination of samples were carried out.

Scheme of the filtration system can be seen on Fig.1.

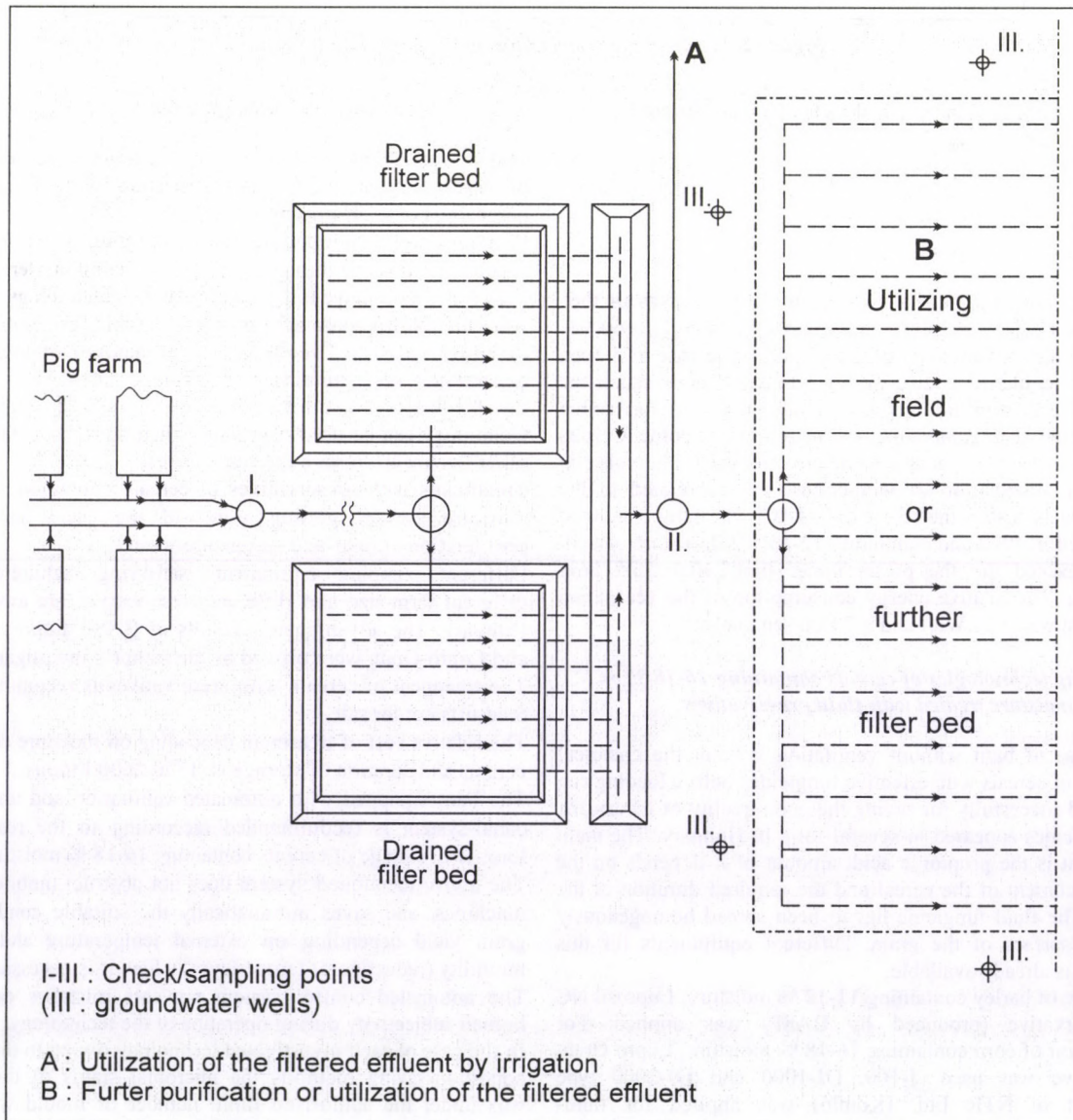

Figure 1 Slurry separation by soil filtration (soil filter beds + drained fields)

3. Results

Table 1 Main characteristics of the pig farms and filter beds

| Denomination | Unit of measure | Measured values | |
|---------------------|----------------------|-----------------|------------------------|
| | | Pig farm 'A' | Pig farm 'B' |
| Size of pig farms | head of sows | 500 | 1,200 |
| Housing system | - | litterless | litterles and littered |
| Feed consumption | t/a | 4,000 | 3,000 ^(1.) |
| Slurry production | m ³ /a | 44,000 | 26,000 |
| Size of filter beds | ha | 2.6 | 4.4 |
| Load of filter beds | m ³ /ha.a | 16,923 | 5,909 |
| | mm/a ^(2.) | 1,692.3 | 591 |

Remarks: 1.) without fattening, 2.) 1 mm = 10 m³/ha, ha = 10,000 m² which is approximately 2.5 acres

Table 2 Filtering efficiency of the filter beds⁽¹⁾ (Pig farm with 500 sows)

| Characteristics (mg/l) | Mean values of samples taken from the slurry collecting pit of the pig farm | Mean values of samples taken from 'M' wells | Filtering efficiency (%) |
|----------------------------------|---|---|--------------------------|
| Total dry matter content | 21,329 | 4,107 | 80.74 |
| Total organic matter content | 15,334.5 | 1,808 | 88.21 |
| Total dissolved matter content | 8,231 | 3,559.6 | 56.75 |
| COD | 33,840 | 2,366 | 93.01 |
| BOD ₅ | 17,880 | 1,331.2 | 92.55 |
| NO ₃ ⁻ | 0.2-1.4 | 0.9 | max. 35.71 |
| NH ₄ ⁺ | 1,268.5 | 596.5 | 52.98 |
| PO ₄ ³⁻ -P | 167.9 | 19.9 | 88.15 |

Notice⁽¹⁾: Mean values of samples of filtered effluent taken from 'M' wells before the recipient.

4. Evaluation of the results, recommendations

According to the analysis and evaluation of test results, as well as the operational conditions of the pig farms, it can be stated that the patented process that can be built by simple an earthwork has favourable characteristics.

On the basis of the test results slurry handling by soil filtration can be recommended to pig farms that have the required conditions, official authorizations, etc. The filtering efficiency of soil filtration can be improved by mechanical prefilter. Further examinations are necessary to clarify some questions concerning enrichment of components in the upper layer of the filter beds.

RELATIONSHIP BETWEEN APPLIED TECHNOLOGY AND QUALITY OF STORED CEREALS

Gy. Komka

Hungarian Institute of Agricultural Engineering

Summary

The author investigated the effect of airing store technology in the aspect of changes in microbiological deterioration of cereals within OTKA project.

The number of mould in air-dried wheat and corn keeping the technological recommendations was considerable lower than authorized limit.

1. Introduction

Certain microorganisms always contaminate the feedstuffs or raw materials. The microflora especially includes bacteria, yeast and moulds. In standard conditions the number of these microorganisms is limited, but in advantageous circumstances for them microorganisms can proliferate in certain amount and consequently cause reduced quality in feedstuffs.

Frequency and rate of microbiological contamination depends on several parameters, including:

- Plant variety and resistance
- Environmental- and weather conditions
- Used agricultural engineering
- Conditions of storage

2. Material and Method

The author investigated especially the effect of storing conditions on microbiological deterioration in feedstuffs, which was featured by number of moulds and changes of mould-flora. The Feed Law determines limit, under which the stored cereal is not objectionable:

- Number of mould: $<5,0 \times 10^4$ CFU/g including
- Potentially toxin-producing genus of mould (*Aspergillus*, *Penicillium*, *Fusarium*, *Alternaria*): $<5,0 \times 10^3$ CFU/g

3. Results of research

Investigation of the following technology was began within the OTKA (T 029438) project lasting more years:

3.1. Air-drying of wheat grain

Pressurised air-drying of wheat in amount of 7,5 tons and height of mass 1.0 meter with 17.0-17.8 moisture content was observed. The microbiological status of the harvested cereal was at low, advantageous level. The author's aim was to maintain or reduce this level during the air-drying and storage. The applied ventilation system was characterised by $300 \text{ m}^3/\text{h}$ ventilation and duration of the drying period was 80 hours. After exsiccation of approximately 3 % the wheat achieved the

14.6 % moisture content, what produced 1.8 g/kg relative exsiccation.

During the nearly 3 month storing period the number of mould and changes of mould-flora was advantageous. The sum of mould-number decreased due to rigorous keeping of technological recommendations and was far under the limit (1st figure).

3.2. Air-drying of corn grain

Investigations were executed between octobere of 1999 and april of 2000 in the case of drawn air-drying storing technology of corn. The ventilation was $90.0 \text{ m}^3/\text{h}$ in large-scale conditions using environmental air-drying in the case of approximately 100 tons corn. The speed of airflow was 0.14-0.23 m/s because of the heterogenous surface of the yield, considering the 1:5 rate of measuring system the mean speed was 0,039 m/s. Samples were taken out from 3 layers (h=0.3; 1.2;2.5 m) of less air-dried yield. Moisture content and temperature of layers were determined with sampling during the experimental period.

The whole duration of the drying was 42.0 hours, which was excessively short, because while the upper layer has 14,2 % moisture content (2nd figure, 1st and 2nd curves), in the lower part of the yield only 0.2-0.3 % moisture reduction was observed after the initial rewetting (3rd curve).

Results of microbiological investigations (3rd figure) proved the insufficiency in practical execution of technology, especially shorter air-drying than it would be required. While the bacteriumflora was not considerable changing, the number of mould increased from 6.0×10^2 CFU/g to 8.6×10^5 CFU/g till the end of storage. It is shown in the figure that the more disadvantageous values appeared in the lower layers. In the upper layers the number of mould was still not higher than the authorised level ($<5,0 \times 10^4$ CFU/g) (in figure 1 and 2 mark), while in the lower layers, in less dried corn (3rd curve), the results were similar or higher than in not-dried corn (4th curve). Results by layers show that acceptable quality of the whole stored yield in microbial point of view can be maintained just till the 110th day of storage. Without airing this period only 15 days.

4. Results

It can be established based on results of recent experiments that ventilation using environmental air of cereals with 16-17 % moisture can be carried out without increase of microbial infection. However there is a stipulation: rigorous keeping of technological recommendations (efficient ventilation, duration of airing, parameters of ventilated air).

It was proved by results of experiments executed with wheat, and partly with corn. In the last case suitable moisture content of the lower layers might have been achieved with required longer airing period.

In the near future the author continues their experiments with air-drying of corn, and try to investigate in details the effect of organic acid treatments on wet cereals in order to decrease the microbial infection and proliferation as they have advantageous results from previous experiments.

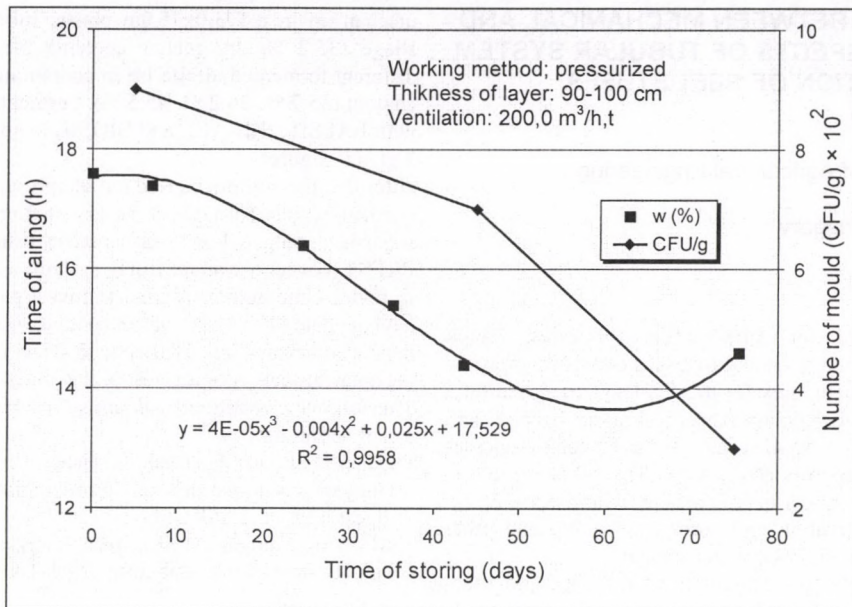

Figure 1 Changes of moisture content and sum number of mould in wheat during the air-drying technology

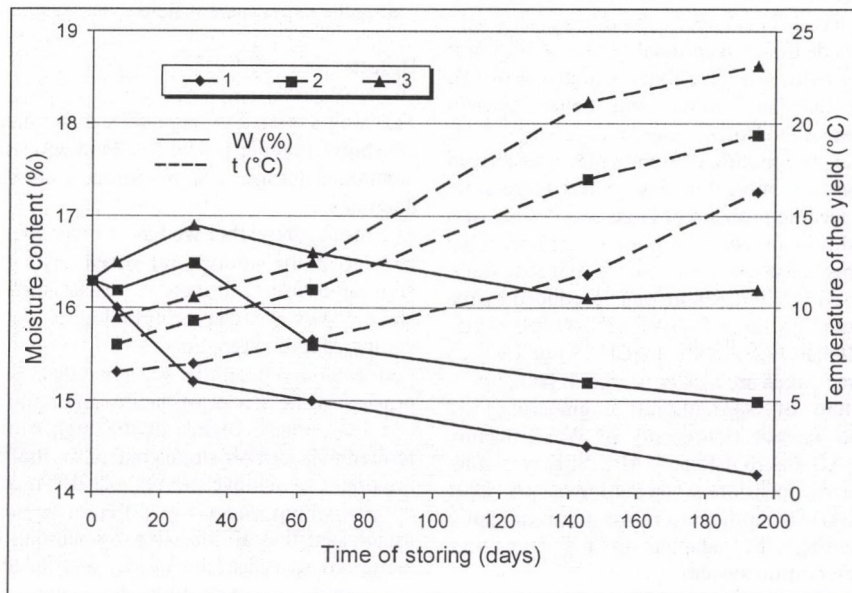

Figure 2 Changes of moisture content and temperature in the case of air-dried corn in 3 layers of the yield

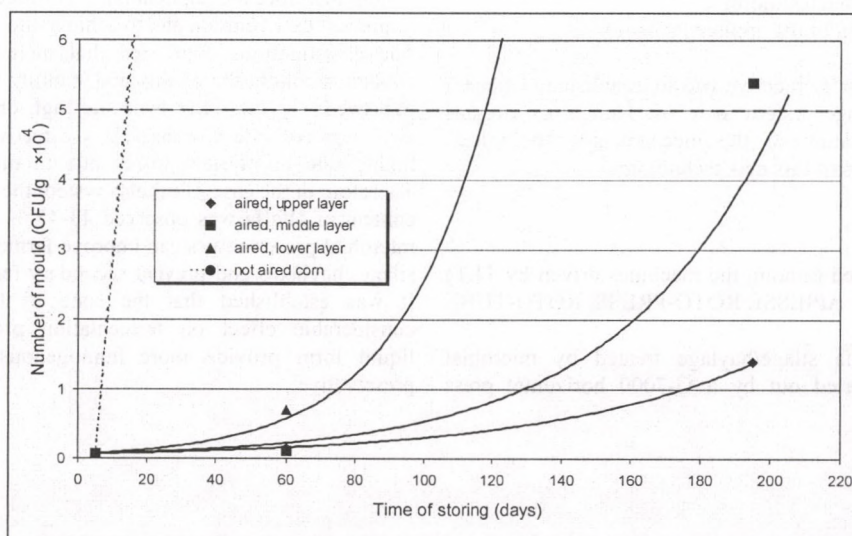

Figure 3 Number of mould in 3 layers of corn yield at air-drying technology and in not dried corn

RELATIONSHIPS BETWEEN MECHANICAL AND NUTRITIONAL ASPECTS OF TUBULAR SYSTEM FOR FERMENTATION OF FEEDSTUFFS (OTKA T 030 031)

Z. Bellus

Hungarian Institute of Agricultural Engineering

J. Schmidt

University of West Hungary

Background and aim

Equipments developed for fermentation processes, which expanded in Western European and overseas countries appeared during the last years in Hungary for the challenge of agricultural production and feeding (bale-wrappers, one-pass baler and wrapper, plastic tubes). Application of these technologies is required for achieve appropriate quality. The tubular presservative system will be shown in this article, which is an up-to-date method for preservation and storage of stalky and other type of forages - based on pressurising system.

The method is suitable for fermentation of stalky and other forages, wet, dried, whole and ground grain, chopped whole plant material and other agricultural by-product (sugar-beet pulp, malt husks, sweet corn husks and tail corn) in form of whole seed, crushed or baled. This technology nowadays is only an additional system beside the conventional bunker silos, but it is expectable to expand because of the reduced nutrient losses, better quality, higher nutrient content and better nutrient digestibility of the stored feedstuffs, moreover owing to its mobile and practical use. The mobile or stabile machines driven by tractor or own internal-combustion engine has large-scale power range, can solve feeding problem of large-scale farms with major livestock, indeed it is suitable for wage-enterprises. One of the prominent systems considering the quality and sold number of machines is the AG BAGGER apparatus produced by the BAG firm and distributed by the AG-BAG HUNGÁRIA Ltd. During the last years Italian (APIESSE, LUCLAR) and Czech (TAUROS) silo-press machines are also appeared in Hungary.

The Hungarian Institute of Agricultural Engineering and Department of Feeding Science (University of Western Hungary) investigated the AG BAGGER and APIESSE type silo-press among the above mentioned technologies in 2001 (supported by the OTKA). The author's aim was to investigate:

- how can this technology be adapted to the Hungarian conservative feed preservation system
- mechanical-technological parameters of the machines
- nutrient content and nutrient digestibility of feedstuffs produced by the mentioned technologies
- economical evaluation of the applied technologies

Summarising the author's objective was to establish and adapt a new preservation-storage system in to the Hungarian circumstances and determination of the mechanical-technological-nutritional relationships of this new technology.

Method

The authors investigated (among the machines driven by TLT) the BAGGER G-7000, APIESSE ROTO-PRESS, ROTO-TUBE type apparatus.

The storage of alfalfa silage/haylage treated by microbial preservatives was carried out by a G-7000 horizontal press

mechanism in a Ø3,0x75,0m plastic tube. Beside the control silage (35.2 % dry matter content) the authors prepared 3 different fermented alfalfa batch containing different dry matter content (35.7 %, 36.2 %, 45.5 %). Fermented alfalfa was treated with LALSIL, SIL-ALL and BIOSIL in concentration of 10 and 2 g^t-1 (1st figure).

After that the authors carried out the preservation and storage of crushed whole corn (36.3 % dry matter) mixed with sliced sugar-beet pulp (21.2 % dry matter) using APIESSE ROTO-PRESS (concentric auger filling system) apparatus (2nd figure).

In parallel the authors started to investigate the press of round haylage bale (47 % dry matter content, *Trifolium pratense*) into plastic tube by an APIESSE ROTO-TUBE machine. The mechanical-technological test of the apparatus was carried out.

The following institutes and firms took part in the experiments as collaborators:

- Department of Feeding Science, University of Western Hungary-investigation of fermentation biology, nutrient digestibility and utilisation,
- AG-BAG Hungária Ltd., Mosonmagyaróvár; Ádám and Co. Ltd., Debrecen – distributors of the technologies and mechanical systems
- AGROPRODUKT Corp., Pápa, Marcalgergelyi; AGRO-FERR Ltd., Dombegyháza; Cukorgyár Corp., Kaba – providing the experimental field

Results

The results related to large-scale experiments and practical view are shown in table 1. The results of chop-slice analyses in above mentioned forages and by-products are shown in 1., 2. and 3. diagrams.

The results show that we have to pay attention to the dry matter content of the alfalfa and sliced sugar-beet pulp, and to the adjustable press. It can be established that applying these technologies we can achieve higher density (with 10-30 %) compared to bunker silo.

Fermentation of alfalfa silage/haylage is the only problematic process in the aspect of quality among the investigated forages and by-products owing to the high puffer capacity and low fermentable carbohydrate content of alfalfa. Therefore it is very important to achieve the optimal dry matter content (30-40 %) by pre-wilting and using different preservatives. The authors established that alfalfa silage containing lower than 30 % dry matter content has poor quality and instable. The effect of low dry matter content (≤ 30 % dry matter) was observed harmful for fermentation processes and stability of alfalfa silage in each system therefore the application of additives is required in order to prevent deterioration and to achieve the appropriate quality.

The investigations confirmed that increasing the dry matter content of alfalfa the quality and stability of the haylage can be improved. On the other hand the high dry matter content has also negative effect: causes less effective pressurisation and higher rate of nutrient losses due to the long term wilting. Therefore in the case of tubular system the maximum dry matter content of alfalfa was observed 43-45 % (as upper limit). The microbial preservatives can improve fermentative parameters of silages/haylages and prevent secondary fermentation processes. It was established that the state of the preservative has considerable effect on fermentation processes and quality: liquid form provide more homogenous distribution of the preservative.

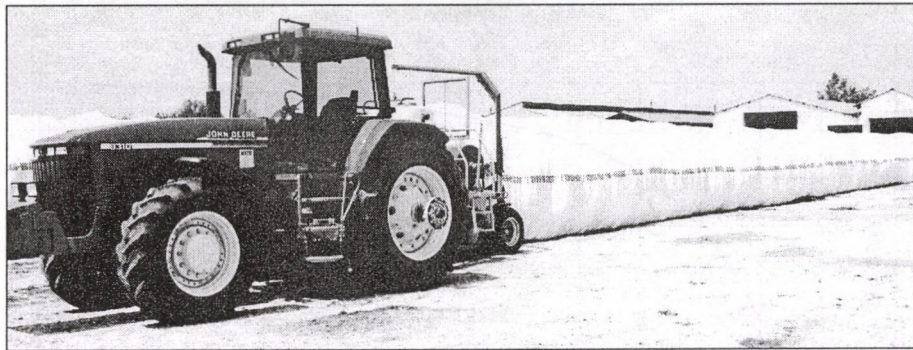

Figure 1

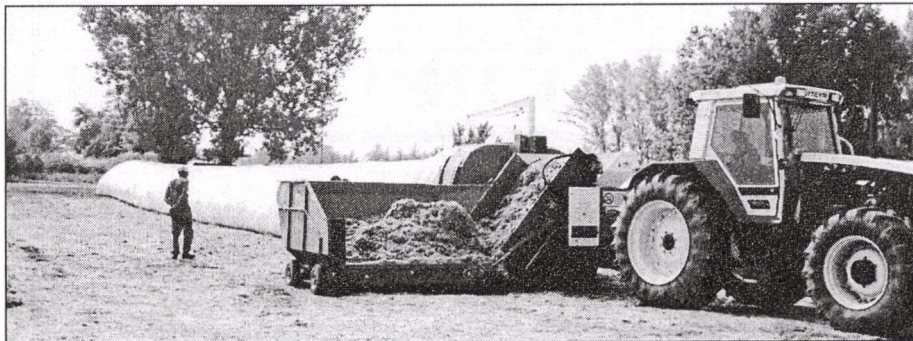

Figure 2



Figure 3

Table 1 The mechanical-technological parameters of press-processes

| Term | Dry matter content | Average chop size (mm) | Density (kgm-3) | Filling speed (mh-1) | Filling capacity (th-1) | Specific energy consumption of filling (kWh/t) |
|---|--------------------|------------------------|-----------------|----------------------|-------------------------|--|
| BAGGER G-7000 alfalfa silage/haylage | | | | | | |
| 1 st treatment | 35.2 | 30.6 | 578.2 | 47.3 | 199.5 | 3.0 |
| 2 nd treatment | 35.7 | 29.2 | 569.6 | 48.4 | 196.7 | 3.1 |
| 3 rd treatment | 36.2 | 29.9 | 575.4 | 49.6 | 193.8 | 3.3 |
| 4 th treatment | 45.5 | 31.5 | 534.3 | 52.2 | 182.3 | 3.8 |
| APIESSE ROTO-PRESS TCR 300 | | | | | | |
| Mixture of whole-corn crushings | 36.3 | 13.1 | 492.2 | 19.9 | 73.22 | 7.8 |
| Sliced sugar-beet pulp | 21.2 | 15.3 | 625.1 | 24.1 | 121.3 | 6.2 |
| APIESSE ROTO-TUBE 170/D | | | | | | |
| Haylage bales | 47.0 | - | 411.6 | 155.7 | 71.5 | 3.3 |

Notes:

1st treatment: control, without preservative

2nd treatment: LALSIL 10 gt⁻¹

3rd treatment: SIL-ALL 10GT⁻¹

4th treatment: BIOSIL 2gt⁻¹

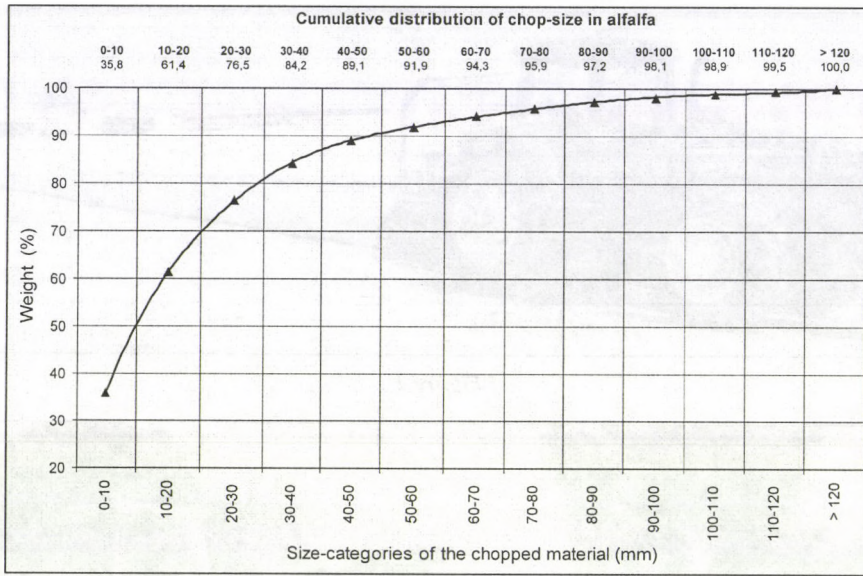

Diagram 1

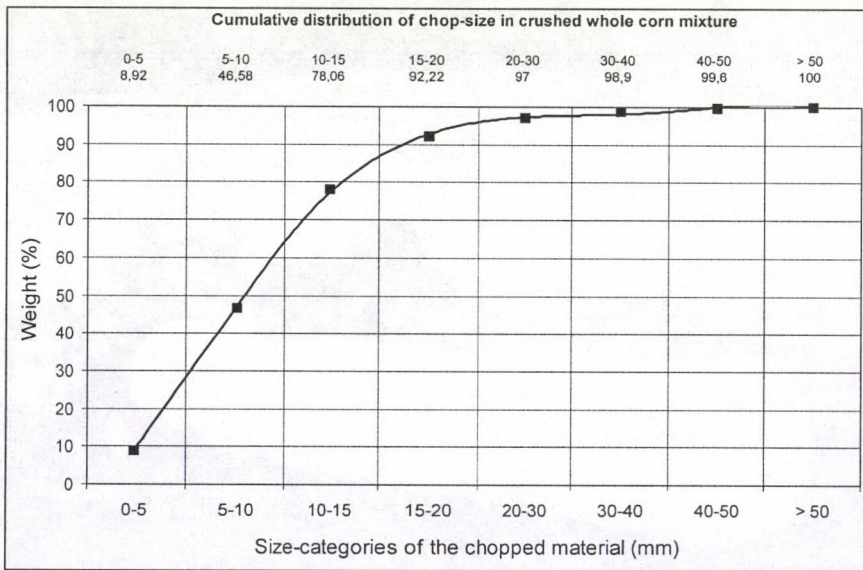

Diagram 2

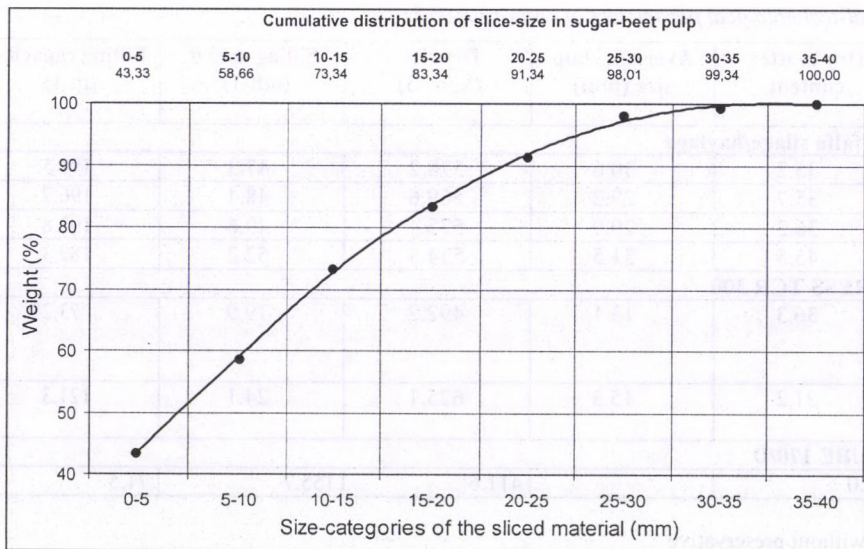

Diagram 3

COMPARISON OF CHAOTIC PARAMETERS OF PERIODIC SIGNALS

L. Baranyai
Szent István University, Faculty of Food Science, Budapest

Summary

The mathematical transformation of an object's outline data set – the polar coordinates of the perimeter pixels of the segmented object – is able to reveal chaos in the shape and create quantitative parameters to describe that chaos. Perimeter is divided into 360 parts – from 0° to 360° - and a map is generated on the basis of differences of radii. Maps show different textures and patterns for different object shapes. Because of the method of computation, these maps are diagonally symmetric. Three statistical parameters (entropy, homogeneity and uniformity of energy) are able to describe texture and successfully classify samples. Furthermore, the presented method is able to analyse any periodic signal. (OTKA F025730)

1. Introduction

Shape recognition is a very important part of digital image processing. Objective description of shape (on the basis of the current grain standards) means the measurement of special parameters, where these parameters describe an ideal expected shape. Computer programs are able to fit mathematical functions to the outlines of selected objects and classify materials according to the parameters of these functions. There are general methods to analyze the whole perimeter (like Fourier transformation), or the perimeter can be split into segments and simple mathematical functions can be applied to each one [1]. Visualization and measurement of chaotic descriptors give additional information and help to classify symmetric, asymmetric and more complex shapes [3]. The complexity of the outline is visualized with attractors (where polar coordinates of the perimeter points are transformed into the phase space) and measured with special functions such as fractal dimension.

2. Objectives

The main goal of this work was to develop a new method to describe the symmetry of shapes.

3. Materials and methods

Digital images of five onion varieties (518 pieces) and images of a sample of seed grains (823 pieces) were acquired. The data sets contained the coordinates of perimeter points of selected objects from the digitalized images. Polar coordinates were used to identify pixels (Figure 1); radial distance and angle were measured from the center of mass point. The angle was relative to the right hand horizontal axis.

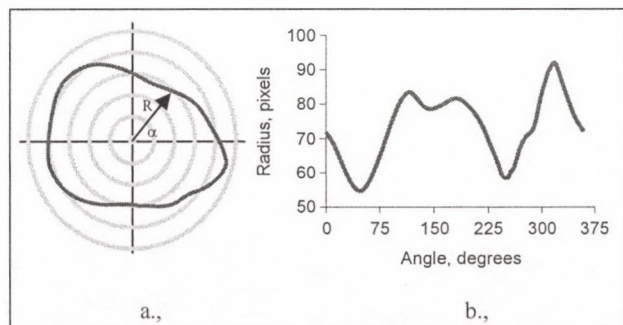

Figure 1 Outline (a) and polar data set (b) for a corn kernel

The whole outline was cut into 360 parts (from 0° to 360°) and the average radius was calculated in each sector. This new data set was used to create a matrix of radial differences as follows (Eq.1):

$$M[\alpha;\beta] = |R_\alpha - R_\beta| / (R_{\max} - R_{\min}) \quad (1)$$

where elements of the matrix are the normalized differences of the selected radii. The values of the matrix are between 0 and 1. A plot of this matrix is called a chaotic map. Figure 2 presents the chaotic map of the mathematical function $Y = \cos(2\alpha)$.

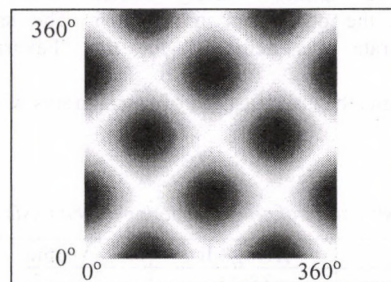

Figure 2 Pattern of chaotic map of function $Y = \cos(2\alpha)$

White represents zero difference between radii ($M[\alpha;\beta]=0$) and black represents the maximal difference ($M[\alpha;\beta]=1$). The structure of the pattern for the cosine function depends on the period. Because the computation of the matrix elements uses absolute values, the generated maps are diagonally symmetric. If the average radii of neighboring sectors have significant differences, special lines will appear on the chaotic map and the contrast will be increased (Figure 3).

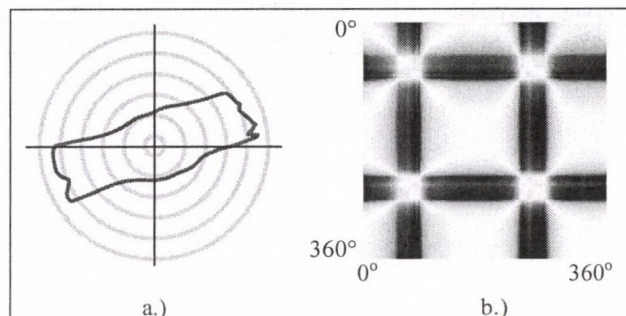

Figure 3 Effect of significant difference of neighbor radii. Original outline (a) and its derived chaotic map (b)

Because the basic data set is periodic, the pattern of tiled chaotic maps of the same object precisely fit (Figure 4).

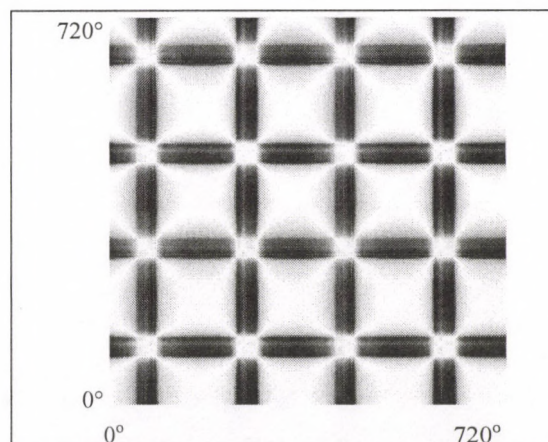

Figure 4. Matching pattern of tiled chaotic maps

If angular orientation of the object is changed, the selected map will be shifted along the main diagonal of the tiled maps. Owing to the matching patterns, displacement of the selected area has no effect on statistical parameters.

Three parameters were selected - out of the more than 300 available in the literature - to evaluate pattern of generated chaotic maps: uniformity of energy, entropy, homogeneity [2].

4. Results

Classification results for five onion varieties are presented in Table 1. The "Sonka" variety differs from the others significantly; the other four are similar. The second best recognition rate was achieved for the "Favorit" variety (66.12%).

Table 2 presents the classification of cereal grains with the same method.

5. Conclusions

On the whole, the presented method is able to analyze symmetry of shapes in digital image processing. Its advantages are the easy computation and the invariance with object rotation. Because polar data sets were processed, this method is also able to analyze any periodic signal.

References

- [1.] FIRTHA F. (1998) "Természeti objektumok alakjának leírása", János Lippay - Károly Vas International Scientific Symposium, Budapest.
- [2.] HARALICK R.M., SHAPIRO L.G. (1992) Computer and robot vision. Addison-Wesley Publishing Company, Inc., 453-505
- [3.] MORIMOTO T., TAKEUCHI T., MIYATA H., HASHIMOTO Y. (1998) "Pattern recognition of fruit shape on the basis of chaos using neural networks", CAPPT 2nd International Workshop, Budapest

Table 1 Classification of onion varieties on the basis of symmetry, % correct

| Variety | Alsógödi | Aroma | Favorit | Rubin | Sonka | Total |
|----------|----------|-------|---------|-------|--------|-------|
| Alsógödi | 38.33 | 16.67 | 20.00 | 25.00 | 0.00 | 100 |
| Aroma | 21.74 | 25.22 | 27.83 | 25.22 | 0.00 | 100 |
| Favorit | 9.92 | 12.40 | 66.12 | 11.57 | 0.00 | 100 |
| Rubin | 17.95 | 21.79 | 11.54 | 48.72 | 0.00 | 100 |
| Sonka | 0.00 | 0.00 | 0.00 | 0.00 | 100.00 | 100 |

Table 2 Classification of cereal grains on the basis of symmetry, % correct

| Sample | Wheat | Corn | Foreign material | Broken wheat | Total |
|------------------|-------|-------|------------------|--------------|-------|
| Wheat | 97.01 | 2.99 | 0.00 | 0.00 | 100 |
| Corn | 1.29 | 83.55 | 0.65 | 14.52 | 100 |
| Foreign material | 8.77 | 24.56 | 59.65 | 7.02 | 100 |
| Broken wheat | 1.79 | 32.14 | 0.00 | 66.07 | 100 |

GRINDING-ENERGETICAL INVESTIGATION FOR DETERMINATION OF BREAD WHEAT'S KERNEL HARDNESS

A. Véha - E. Gyimes - E. Markovics
University of Szeged

Summary

In our research we introduce a new simple measuring method, which seems to be capable of objective and dimensionable determination of kernel hardness as an important energetic and qualitative fact.

We made measurements with the Perten's SKCS 4100 type device and with the PerCon 8100 type device operating on the basis of NIR principle, and with a method which measures grinding resistance during the grinding of wheat items.

For the object of the examination, we chose 17 Hungarian varieties of aestivum wheats with different quality.

We determined that all the three kernel hardness defining methods are capable of determining the kernel structure; the correlation between the measured hardness values is relatively close ($r = 0,663 - 0,847$).

Another remarkable result is that correlation between the results of the kernel hardness measuring methods is good, medium strong ($r = 0,66-0,85$). Hereby we can suggest that in spite of calibration difficulties, devices operated by NIR principles can be able to determine not only the quality, but the kernel hardness values, too.

Introduction

Experts in milling industry have been interested in kernel hardness of wheat for a long time. This kernel hardness can be defined as physical hardness, but also as amount of energy necessary for grinding and crushing.

Kernel hardness affects the grinding properties, utilization areas of grists and different qualitative parameters of produced flours (Bedő et al. 1998, Láng et al. 1999, Matuz et al. 2001/a, Matuz et al. 2001/b).

Determining kernel hardness value of wheat is very important in selling wheat, because it affects the quality of produced grists, flours.

A lot of, often similar, physical and chemical measuring systems and procedures have been worked out worldwide for qualification of grain and the finished products produced from them (Vida - Bedő 1999).

Several researchers tried to solve the problem of objective determination of wheat kernel hardness, but none of these methods was accepted internationally.

American researchers (MARTIN, STEELE 1997) by the cooperation of the Perten Company have developed a kernel hardness-measuring device, which defines the grinding-force necessary for the grists.

By this method the so-called Hardness-index can be determined, which is mainly used in the American milling industry and trade for qualitative acceptance test.

Single Kernel Characterization System 4100 defines this hardness-index by examining four physical parameters together. According to GAINES (1996) it is also suitable for reliable and exact predicting of the hardness - which greatly affects the qualitative properties, - already in the period of wheat breeding. Many researchers dealt with energetical and granulometric analysis of the grinding of grains.

BÖLÖNI-BELLUS (1998) pointed out that the so-called specific superficial grinding energy demand (e_g), as a basic physical parameter, is a very important fact during the grinding. Analysis of the processes during grinding (BÖLÖNI et al. 1997), and energetical evaluation of kernel hardness of grains led us to deeper knowledge of this problem.

Beside constant specific superficial grinding energy consumption, determining the specific superficial grinding energy demand is capable to define kernel hardness of different grains, because this value means the energy consumption needed to produce 1 cm² grit surface (VÉHA et al. 1998).

So, determining the resistance of the kernel structure against grinding is based on special energetic and granulometric examinations, and on the basis of this we can make numerical the necessary grinding energy demand (mWh/cm²) (VÉHA - GYIMES 1999).

The aim of investigations

Our research, with the help of selected Hungarian wheat varieties with significant differences in inner contents and physical characteristics, had the following objectives:

Determining the specific superficial grinding energy consumption values (mWh/cm²) of grists, and checking whether wheat varieties have significant differences in their so called grinding resistance values (mWh/cm²), (i.e. physical kernel hardness).

Comparing the defined grinding resistance values with the NIR hardness values measured by the Perten Percon 8100 device and with the hardness-index (Hi: %) values determined by Perten SKCS 4100.

Searching for correlation between kernel hardness values.

Materials and methods

We made our experiments at the University of Szeged, College of Food Engineering, Department of Food Technology and Environmental Management.

We conducted investigation into 17 wheat varieties cultivated in the Cereal Research Non-Profit Company, Szeged, and these were the following: GK-Élet, GK-Sára, GK-Malmos, GK-Cipó, GK-Kalász, GK-Tenger, GK-Jászság, GK-Miska, GK-Mérő, GK-Rigó, Jubilejnaja 50, GK-Óthalom, GK-Forrás, GK-66-96, GK-64-96, GK-Zugoly, GK-Favorit.

Method of determining grinding resistance (e_g : mWh/cm²) (Fig. 1.)

The method is based on a grinding operation with a controlled parameter, where we registrate the specific energy requirement for the grinding (mWh/g) during the grinding of the sample and by the help of sieve analysis we determine the specific surface of the produced grit (cm²/g). 500-500 g samples are necessary from each wheat variety for grinding process, which will be ready in 60 s (1 min) on average. Dry grain ($w = 10,5-12,5\%$) must be stored in a kb. 10 dm³ volume reservoir (1). The grains get into the grinder with closed grinding space (Falling Number type grinder) (6) by the help of a cylinder (cellular) dozier machine (2). We have to load the electric drive engine (9) to take in the nominal power, which has to be controlled by a digital (EKM 265 Conrad type) consumption meter (10) and an analogue wattmeter (11). Because of the constant feeding mass stream (30 kg/hour) in case of wheat varieties with different kernel hardness, the nominal motor power (W) can be ensured by a special double sliding sieve construction mounted in the grinder (12). This was constructed based on the patent of dr. István Bölöni, mechanical engineer. According to the above mentioned facts, grinding resistance of wheat samples will be affected by the variable sieve value of the grit-fineness setting device, the feeding mass stream and the constant power value of the electric motor.

After the grinding cycle, we measure weight of produced grists (g) by a precision scale (13). After homogenization of the grists we subjected 100 g of representative sample to a sieve analysis

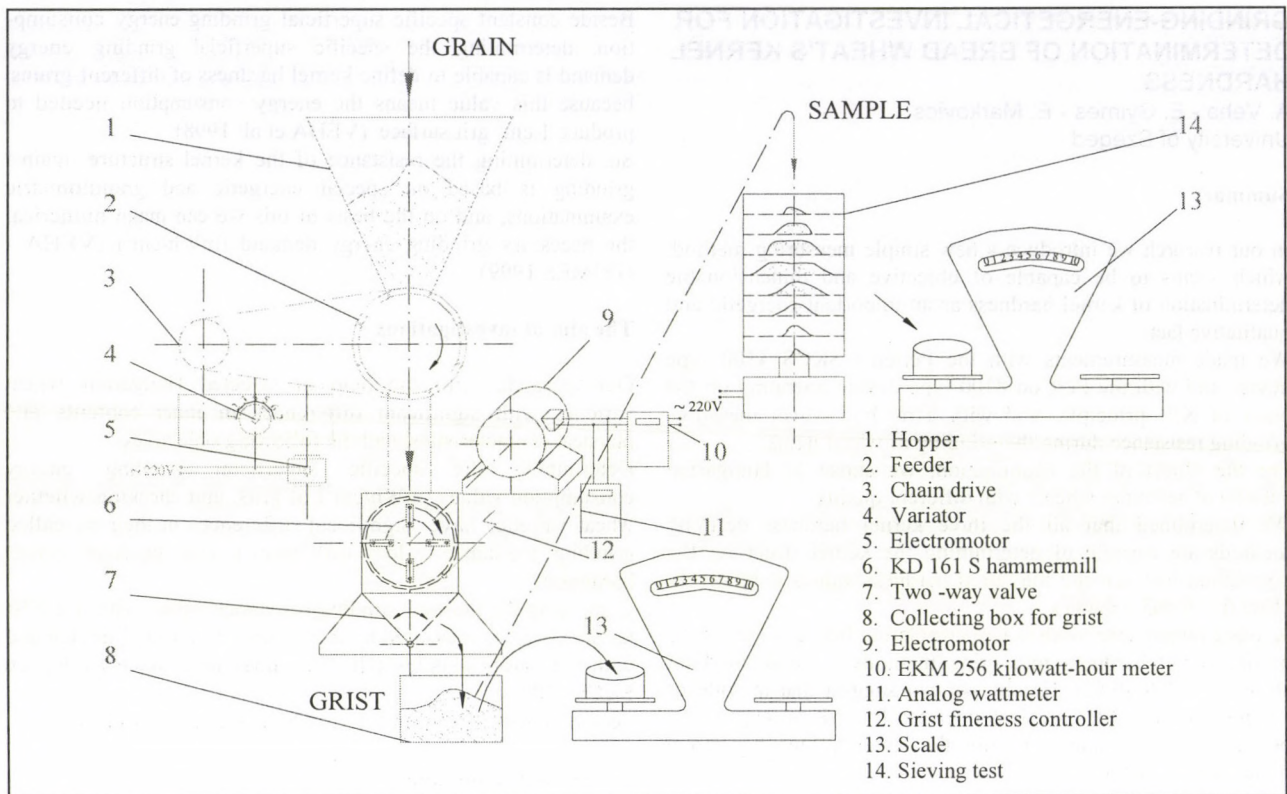

Figure 1 Measuring scheme of grinding resistance

(14), which will give the average kernel size and special surface of the grits based on the sample sieves rest values (R: %).

By this method, we determined the kernel hardness typical for the wheat varieties, the grinding energy consumption for 1 cm² new grits surface.

In the case of one wheat variety 6-6 samples were ground and evaluated after sieve analysis, which took 5-6 minutes in case of one variety.

Hardness-index measuring with Perten SKCS 4100 device

To determine Perten's kernel hardness index (Hi: %) we used a SKCS 4100 type device, which gave not only the mean hardness index, but the mean grain size, the grain mass and the moisture content as well.

To determine hardness index (Hi: %) with a Perten device we used 300 grains per sample and repeated the process three times.

NIR-hardness measuring with PerCon 8100 NIR device

The device has 6 filters, and mounted into the mass stream it can measure the components of flours and other dusty material, which formerly were controlled by hand.

According to the calibration the instrument simultaneously prints out the ash content of the grit (a:%), water content (%) and the wheat kernel hardness value.

Results

The kernel hardness of 17 GK wheat varieties we defined by two destructional methods (Hardness index: Hi, grinding resistance: e_r) and a destruction-free method (NIR-PerCon 8100). See Table 1.

Regarding the averages, the varieties show good medium kernel hardness. Hard-soft limits in case of each method were as following: in case of NIR, below 40 NIR, the kernel is soft; above it the kernel is hard. In point of hardness index, the limit value is 50 %; while at the grinding resistance the kernel hardness limit is 65 mWh/cm². The NIR hardness and the Perten Hardness index are in strong, significant connection (r = 0,847). While the two destruction methods (Hardness index and grinding resistance) show medium strong (r = 0,663), but significant correlation (on 1 % probability level).

The correlation is similarly close (r = 0,666) between methods of NIR hardness and grinding resistance, which is significant (on p = 1 %).

Acknowledgements

We would like to thank the Cereal Research Non-Profit Company, Szeged for providing true to variety wheat samples. We would also like to thank Dr. Matuz, J. (PhD.) wheatbreeder and Dr. Bölöni, I. (DSc.) consultant for their help and support.

Our investigation was financed by research programs: Hungarian Scientific Research Fund (OTKA) No. T 030009 and F 029631.

Table 1 Correlation matrix of examination results (n=17)

| HARDNESS - TEST | NIR Hardness | Hardness index Hi (%) | Grinding resistance e _r (mWh/cm ²) |
|---|--------------|-----------------------|---|
| NIR - hardness | 1 | ***0,847 | **0,666 |
| hardness index Hi (%) | ***0,847 | 1 | **0,663 |
| grinding resistance e _r (mWh/cm ²) | **0,666 | **0,663 | 1 |

Remarks: FG=16, p= 0,1 % r=0,708 ***, p= 1 % r=0,589 **, p= 5 % r=0,468 *

References

- [1.] BEDŐ, Z., LÁNG, L., VIDA, GY., WESZELYNÉ, V.H. (1998): The endospermium structure of Martonvásár wheat varieties (Martonvásári búzafajták szemtermésének endospermium szerkezete) Martonvásár (az MTA Mezőgazd. Kutatóintézet Közleményei) 2., pp. 7-8.
- [2.] BÖLÖNI, I. - BELLUS, Z. (1998): Applying two-variable energetic functions in feed grinding Hungarian Agricultural Engineering, No.11. pp. 30-31.
- [3.] BÖLÖNI, I., - VÉHA, A., - GYIMES, E. (1997): The Influence of the Wheat Hardness on Some Energetic Characteristics of Grinding. International Wheat Quality Conference, Manhattan, KS. Proceedings p. 494.
- [4.] GAINES, C.,S., FINNEY, P.L., FLEECE, L. M., ANDREWS, L.C. (1996): Predicting a Hardness Measurement Using the Single-Kernel Characterization System. Cereal Chemistry 73. pp. 278-283.
- [5.] LÁNG, L. - BEDŐ, Z. - JUHÁSZ, A. - WESZELYNÉ, V.H. (1999): Investigation of wheat kernel hardness (A búza malomipari minőségét jelző szemkeménység vizsgálata) V. Scientific Research Days of Plantbreeding, Hungarian Academy of Sciences, Budapest Abstracts p. 21.
- [6.] MARTIN, C.R., ROUSSER, R., BRABEC, D.L. (1993): Development of a Single-Kernel Wheat Characterization System. Transactions of the ASAE 36 (5) pp. 1399-1404.
- [7.] MARTIN, C.R., STEELE, J.L. (1997): The Single Kernel Wheat Characterization System (SKWCS). International Wheat Quality Conference, Manhattan, KS. Proceedings p. 504.
- [8.] MATUZ, J., BEDŐ, Z., ÁCSNÉ (2001): Kernel Hardness and Breadmaking Quality Parameters
- [9.] by "Szeged" Winter Wheat Varieties VII. Sciences Days of Plant Breeding, Hungarian Academy of Sciences Budapest Abstract p. 61.
- [10.] MATUZ, J., KERTÉSZ, Z., PAUK, J., CSÓSZ, M., FALUSI, J. (2001): New GK wheat varieties on the Hungarian market (Új GK búzafajták a nemzet piacán)
- [11.] Molnár Lapja (MÉTE) 106/4 pp. 5-9.
- [12.] VÉHA, A., - GYIMES, E. - BÖLÖNI, I. (1998): Investigation of wheat kernel hardness of different varieties by means of measuring grinding resistance Hungarian Agricultural Engineering, No.11. pp. 15-16.
- [13.] VÉHA, A. - GYIMES, E. (1999.): Investigation of Kernel Hardness in Winter Wheat Varieties with Hammermill Cereal Research Communication Vol. 27. No.4 Szeged pp. 463-470.
- [14.] VIDA, GY., - BEDŐ, Z. (1999): Use of principal component analysis in correlation studies between kernel hardness and other breadmaking quality traits in winter aestivum and durum wheat genotypes Növénytermelés, Tom 48. No.1. pp. 33-42.

PRESSURE AND VELOCITY FIELD MEASURING IN THE ENVIRONMENT OF IMPELLER OF AXIAL FLOW FAN

F. Szlivka, Szent István University, Gödöllő
J. Kópházi
Budapest University of Technology and Economics

1. Abstract

We have report our researches about the determination of developing flow pattern in the axial flow fan impeller promoted by OTKA (T 026516) in our researches about the calculation of flow pattern [1]. As a further development of this research topic we review that measuring method which is based on pressure measuring and has been developed for the measuring of evolving velocity and pressure field in the environment of impeller of axial fan. Compared this improved measuring method to the measurements that have been done with the formerly used Laser Doppler Anemometer (LDA) we can say that the results of this new method are very well applicable at the measuring of velocity field in the environment of impeller in addition to this is right for to determine the pressure field. In this way we have determined the spatial distribution of static pressure directly behind the impeller as well as the spatial distribution and direction of total pressure in a fixed system to the blade channel. Using of this method you can record the pressure distribution not only one but even all of the blade channels. Therefore we had an opportunity to map locally the waste sources of fluid mechanics processes in the impeller: to determine the pressure loss and the hydraulic efficiency at each points what we can't do if we only know the velocity field.

2. Introduction

At the Department of Fluid Mechanics of Technical and Economical University of Budapest we have built a "from pipe to pipe" transport horizontal axial flow fan test station with automatic type and efficiency characteristic measuring method. We have given information about the details of this equipment in the presentation [2]. The details of instrumentation and geometry of the type and efficiency measuring device have been presented also in the article [2]. The characteristics of Ø630 mm axial flow fans with upstream and/or downstream deflector can be determined by this device. We improved such a fans which have different hub ratio and blading as well as determined the efficiency- and the other characteristic curves of these fans with this measuring machine. For the more precise comparison of the results of proportioning and measuring as well as the specifying of proportioning method we aimed at the research of the fine structure of flow pattern. One of the main way of the measuring of fine structure is the developing and application of the LDA-appliance in the research of the details of the developing flow in the environment of blading of fan impeller. János Vad and Ferenc Bence have already carried out researches in this topic for ages. [3], [4].

With the help of the LDA measures it managed to specify the fine structure of velocity field which develops behind the impeller blading. This measuring method is created by the research team is right for measuring of all three of velocity field components. But it doesn't give any point of reference about the changing of pressure ratio. Using the measuring method published in this publication you can measure in addition to the velocity field in the environment of the impeller the fine structure distribution of pressures. However we have undertaken to measure only two velocity components with this method. According to the experiences of LDA measures this gives a good approach because the radial velocity is small in comparison with the other two components [4].

3. Pressure probes

In this case the probes have to meet a lot of hard demands. They need to have a very fast recovery time that they can follow the unexpected pressure changing which are made by the blades of impeller. The signs of pressure probe can't transmit as pressure but they have to forward them as electrical signs to the place of analysis. Because of even some "cm" long pressure pipe can make a big distortion in the pressure pattern which is changing in a hundredth part of a second. Therefore the probe has to be set directly at the place of measuring and it's dimension should be small as required; approximately 1 "cm" or less. The range of pressure changing is some hundred Pascals, therefore the microphone or the piezo-crystal pressure gauge were chosen. Their working method is similar with the microphone's and it meets the above mentioned requirements. The piezo-crystal pressure gauge is a differential pressure gauge type. At one of it's side has to set up a constant reference pressure which was the outer atmospheric pressure through the leg of the pressure gauge. A total pressure sensor Pitot-tube, and a cylinder-probe, or the static pressure sensor Ser-disc have been set to the pressure changing sensor side of the transducer. The **Figure 1** shows the probes. The diameter of Ser-disc is 5 mm with a Ø1 mm hole, the diameter of Pitot-tube is 2 mm with a Ø1 mm hole. The leg of the cylinder probe has 2 mm diameter, with a Ø0,3 mm total pressure hole. The dimensions of probes ensure that the spatial dissociation of measuring points can be almost equal to the dissociation of LDA.

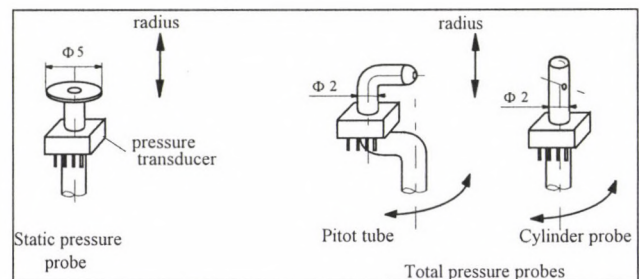

Figure 1

Because of the figuring of the static and total pressure probes the positioning can be done precisely in the radial direction and in case of total pressure probes in the turning direction in relation to the axis of probe. The velocity field behind the impeller changes periodically in the tempo of passing blades. The frequency of changing is equal to the product of number of blades and rpm. Therefore the probe is set in absolute system registers periodically or almost periodically changing pressure. Inasmuch as the flow pattern is examined attached to the blading then it can be considered almost steady if the turbulence fluctuations are absorbed from the flow pattern which can do by proper number of averaging.

From the non-steady string of pressure probe compared to blades we have to sum the samples from the same area and the averaging of these values give the pressure or velocity component which are attached to the blading and measured in the absolute system. The accuracy of sampling is ensured by an angle transducer which is fixed on the shaft.

The sum recovery time of probes and pressure transducers have been checked by different measures and calculations. In several cases we have done pressure form measures in the same working points at different speeds. The **Figure 2** shows a comparison from these. The pressure form has been measured on $n=12,66$ [1/s] and $n=18,33$ [1/s] speeds and different radiuses on two blade channels. When the results were described as a dimensionless characteristic good coincidences have been experienced in all cases. It is refer to the recovery time of the pressure probes doesn't mutilate the measuring signs

in the measured rpm range. The pressure probes were sensitive to warming-up therefore calibrations were applied before – and after every pressure form measure. (We attribute the little displacement of pressure curves compared to the zero pressure to the calibration.)

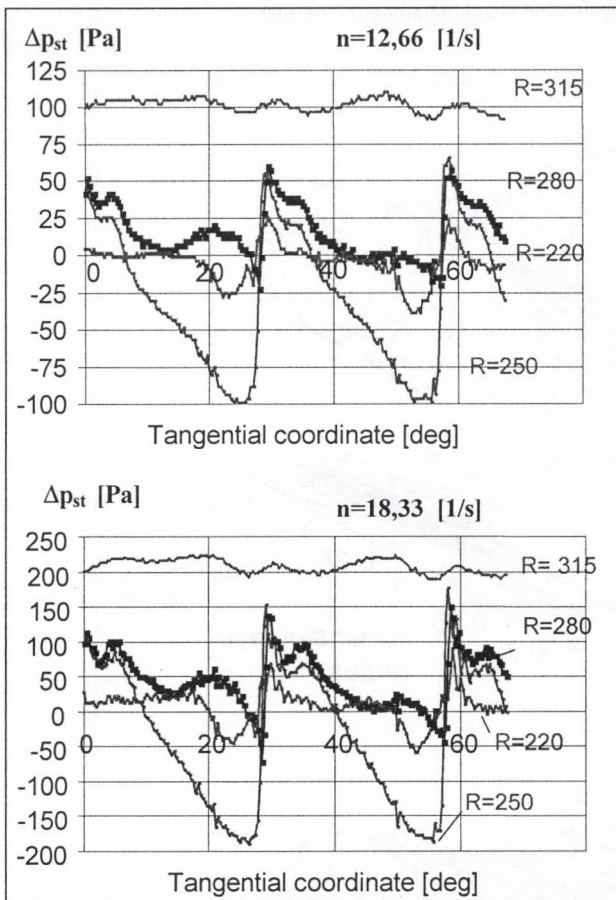

Figure 2

4. Determination of static and total pressure

The static and total pressures were measured in different times. According to LDA measures the radial velocity is much smaller than the other two components. There is no problem to measure the static pressure if the velocity in radial direction is small as well as there is only a little parallel different between the level of Ser-disc and the direction of velocity. The bigger problem is at the **total pressure measuring**. In a certain point (at certain radius and angle compared to the blading) we can measure the total pressure in that case if the hole of total pressure probe (in case of Pitot-tube and cylinder probe too), is exactly in front of the instantaneous velocity. Behind the fan blading the direction and magnitude of velocity change continuously therefore during the rotating of the impeller the input direction and magnitude of flow at the total pressure probe change continuously too. To set the total pressure probe in a certain setting radius and direction a pressure form function can be plotted against the perimeter direction. To average this in several turnings around we get a periodical function as blade spacing. **Figure 2**. (The turning angle around the own axis of total pressure probe is marked with α . The $\alpha=0$ equation will be right if the direction of total pressure probe is parallel to the axis of pipe and points in the face of the flow.) But this is not the curve of total pressure. If we turn the total pressure probe around along it's axis into another position then a different curve can be got along the circumference. If the pressure form is determined at adequate number of total pressure probe position than from the different

curves we can select the biggest pressure value and at the same time the velocity direction value α_{max} too.

The obtained flow directions correspond very well with the directions getting from LDA results. Of course the radial velocity component can't be determined by this method. Same measures have been done with using of Pitot-tube and cylinder probe too. There weren't significant difference regarding neither the direction nor the volume.

5. Measuring results and developing possibilities

These measures were carried out by us behind a BUP-29 typ. impeller of Department of Fluid Mechanics of BME at right angles plane to the axis, at approximately 20mm distance from the leaving edge of impeller blades. BUP-29 typ. impeller has 12 blades. The central angle of a blade channel is 30° . During our measures we recorded the measuring results of seven blade channels and from these we published results belonging to more than two blade channels which corresponds to 70° central angle. From our measures which are made in the environment of the best efficiency work point has ($\Phi=0,46$; $\psi =0,54$; $\eta=77\%$) macro characteristics we present the ideal and the real spatial distribution of the total pressure along two blade channels plotted against the dimensionless radius on the **Figure 3**. Local ideal total head rise coefficient and local (real) total head rise coefficient.

$$\Psi_{id} = \frac{\Delta p_{idt}}{\frac{\rho}{2} \cdot u_k^2} \quad \Psi = \frac{\Delta p_t}{\frac{\rho}{2} \cdot u_k^2}$$

Hub-to-casing ratio: $v=0,676$; casing radius: $r_c=315$ mm; hub radius: $r_a=213$ mm.

Fine structure measuring have been done at several points of the fan characteristic. The **ideal total pressure-coefficient distribution** was calculated according to the well-known Euler-turbine equation from the perimeter direction component of velocity which had been calculated from the static pressure from the Pitot-tube and Ser-disc measures. $\Psi_{id}=2c_t/u_k$; where c_t is the local tangential (perimeter) velocity. (The tangential component is zero in front of the impeller as there is no prerotation at upstream.)

The **real total pressure-coefficient distribution** was calculated as the difference of total pressure which was measured behind the impeller in every points, and the average total pressure which was measured in front of the impeller. Using these two data we have determined the charts of efficiency and loss at every points too, but we can't present them here because of the size limits of this publication. The given measuring results were transformed to a rectangular region form in order that we can make a good comparison between these results and the results of LDA measures publicised in [3], [4] references.

The macro characteristics of work point were calculated by averaging the results of our fine structure data (see **Figure 3**) which show a good agreement with the given results of characteristic measure.

Because of our measuring results we set ourselves to develop further the calculating method published in the reference [1].

Acknowledgement

The research is promoted by OTKA (T 026516)

References

[1.] F. SZLIVKA - M. LOHÁSZ: Flow Pattern Calculation is an Axial Flow Fan Cascade, Hungarian Agricultural Engineering 2000/13 pp.:59-60.

[2.] BENCZE F.- FÜREDI G- KESZTHELYI I.- SZLIVKA F. (1991) "Design and Measurement Experiments of Axial Flow Fans" Proceeding of 9th Conference on Fluid machinery, Budapest
 [3.] Vad J. AND BENCZE F. (1998). "Laser Doppler Anemometer Measurements Upstream and Downstream of an Axial Flow Rotor Cascade of Adjustable Stragger", 9th Conference on Flow Measurement (FLOMEKO), Lund, Sweden 579-584

[4.] VAD J. (1994) "Sugár mentén változó lapátcirkulációra méretezett axiális átömlésű ventilátorok mögötti sebességter vizsgálata lézer Doppler anemometerrel" Ph.D értekezés Budapesti Műszaki Egyetem Áramlástan Tanszék, Budapest (Velocity field examination of axial flow designed for blade circulation changing along the radius)

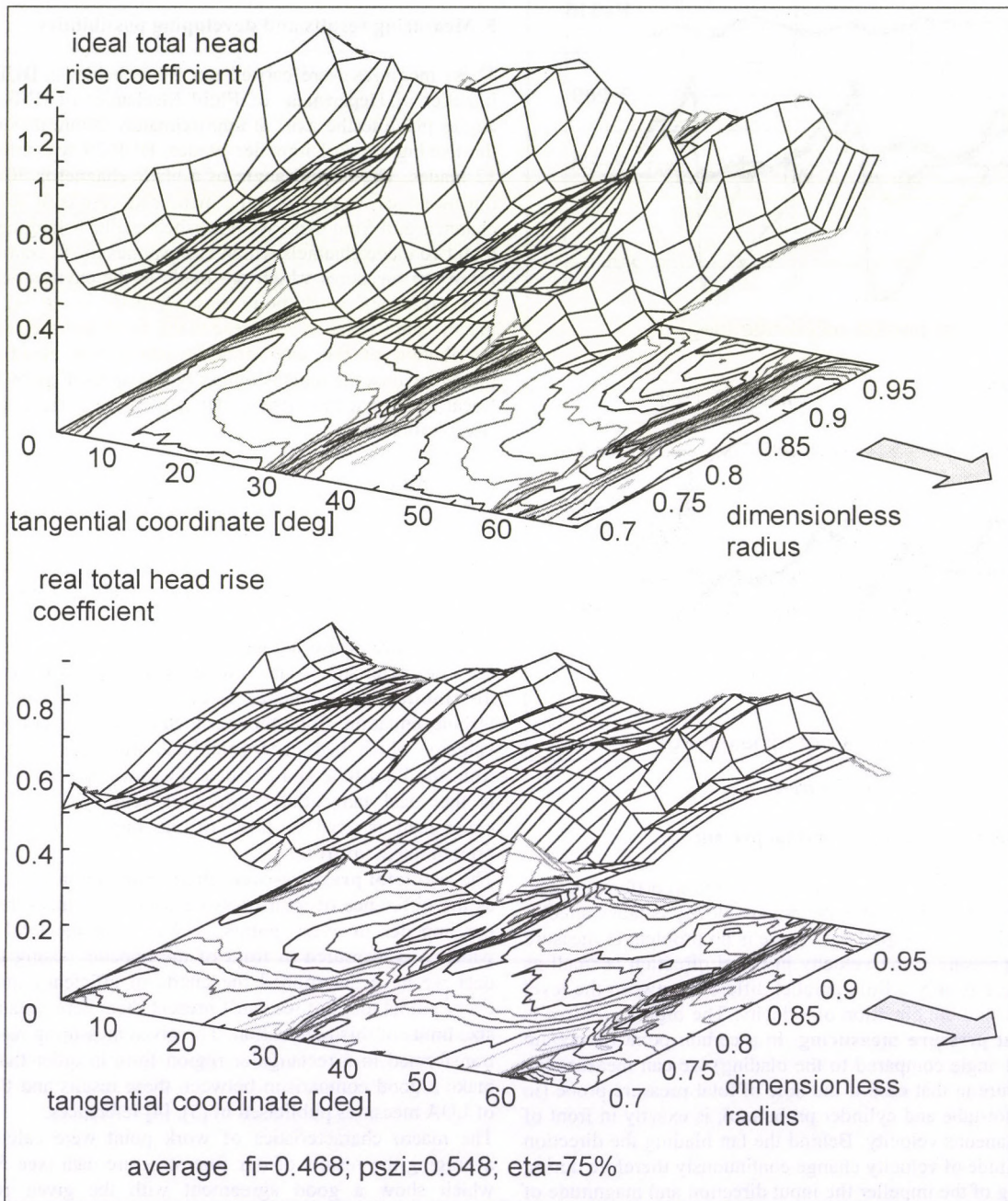

Figure 3

DETERMINATION OF CRITICAL CONDITION OF CHOPPED STRAW MASSES WITH IMPEDANCE MEASURING

L. Bense - P. Szendrő - Gy. Vincze
Szent István University, Gödöllő

Modelling the method of rheological research the determination of loading for the evolution of anaerob conditions is a cardinal point. The research is of fundamental importance because the methods from the scientific literature [1, 2, 3] are connected with the technology of processing in respect of the adopted loading, too. However successful processing does not mean that we have really adopted the loading pertain to the anaerob critical condition. Our assumption is that the anaerob critical condition can be determined directly without measuring voids volume of the mass is being compressed.

While compressing the chopped straw mass its internal structure changes. The structure change is followed by the changing of several physical features such as porosity, certain rheological features (relaxation material functions), thermal (specific heat, thermal conductivity) and electric parameters. Besides the changing of physical features the chemical and biological features were also changed. Among the latter the most important changing is the speed of metabolism. Namely it determines the speed of biological value loss and internal heat evolution. The conclusion is that the silo maize chopped straw has such a stable internal structure, which according to the latest standpoints is the best.

Stable internal structure is an isotropic and homogeneous structure on macroscopic scale. It is a logical assumption that the appearance of the stable internal structure is showed by the stationary physical features. On the basis of the above-mentioned facts the structure change of the chopped straw during compressing can be regarded as a higher phase transform when the continuous change of a certain group of physical parameters is followed by one or more non-continuous change of physical quantity.

A method for measuring chopped straw mass impedance

We put the chopped straw sample into an insulated cylinder that is locked by a movable piston. We set the density and mechanical tension of the chopped straw with the piston. The piston and the bottom plate got an aluminium cover so in electric respect the sample holder unit can be regarded as a mansbridge capacitor (Figure 1). This capacitor is joined the type TR 2152 RLC measuring bridge and making use of it we can measure the impedance of sample during compressing. The physical quantities measuring with impedance are the followings: sample bulk, mechanical tension and moisture content. The measurements were done with constant sample volume ($V=3,4636 \cdot 10^{-4} \text{ m}^3$) since the distance of the capacitor coatings has to be constant in every measure (40 mm in this case).

Theoretically, the RLC measuring bridge is suitable for the direct measure of capacity but in the case of insulated electrodes because of the conductivity of the moist crop the small capacitor plate surface ($A=7,8539 \cdot 10^{-3} \text{ m}^2$) reduces the sample capacity under the measuring range ($<10 \text{ pF}$). The electric conductivity of the sample is precludes the possibility of resistance measuring with simple direct current so we examined the suitability of the experiment limited to impedance-measuring for determining specific resistance change.

Impedance measuring analysis

During the measurement I supplied the sample with 1 kHz frequency so the field strength of it is time changing. Due to this fact, two kinds of current flows through the sample: the ohmic

current, which is proportional with the field strength and the displacement current, which is proportional with the time derivative of the field strength. On the grounds of it the electrical substitutive equivalent of the sample is a parallel connection between resistance and capacity (Figure 2). On the basis of the sample the capacitor capacity can be estimated:

$$C = \varepsilon_0 \varepsilon_r \frac{A}{d} = \frac{1}{4\pi 910^9} 4 \frac{7,85 \cdot 10^{-3}}{0,04} = 6,94 \cdot 10^{-12} \text{ F}$$

The following capacity reactance belongs to the pF order of magnitude on the measuring frequency of the bridge:

$$X_C = \frac{1}{2\pi f C} = 2,29 \cdot 10^7 \Omega$$

This is a quite big value and is 4-5 orders of magnitude bigger than the ohmic resistance of the sample. So the capacity can be omitted on the substitutive equivalent (Figure 2) and we do not wrong while considering only the ohmic resistance of the sample.

Impedance measuring evaluation

The evaluation of the measurement is based on the specific resistance of the sample. I examined the changing of the specific resistance of the sample plotted against an appropriate variable group. It is told that the sample in stable status is isotropic and homogeneous on a required macroscopic scale.

It is known that the specific resistance in the case of such samples is $g = \frac{R}{l} A$ where A is the cross section of the sample

and l is the length of it. We examined the dependence on other physical parameters of the specific resistance with dimension analysis. Considering that the cross section of the sample and the distance of the capacitor coatings are equivalent in every

measure the $R \left(\frac{l}{A} \right)^{-1}$ quantity can be chosen for the resistance

drawing. It is obvious that the g_0 specific resistance of the chopped straw material is influences the resistance of the sample so the g_0 quantity is also needed for the description of the phenomenon. During the compression joint places are come into existence and among these joint places a so-called contact resistance occurs. The contact resistance depends on the g_0 quantity, the magnitude of joint place and the number of joint places. The magnitude of joint place depends on the σ mechanical tension and the σ_{BY} biological plastic limiting stress. And the number of joint places depends on the stress and the ρ_0 starting and ρ forming mass density. So the following

physical quantities describe the problem: $R \left(\frac{l}{A} \right)^{-1}$, g_0 , σ , σ_{BY} , ρ_0 , ρ .

The following dimension matrix belongs to these quantities:

| | m | s | kg | A |
|-------------------------------------|----|----|----|----|
| $R \left(\frac{l}{A} \right)^{-1}$ | 3 | -3 | 1 | -2 |
| g_0 | 3 | -3 | 1 | -2 |
| σ | -1 | -2 | 1 | 0 |
| σ_{BY} | -1 | -2 | 1 | 0 |
| ρ_0 | -3 | 0 | 1 | 0 |
| ρ | -3 | 0 | 1 | 0 |

It can be seen that the number of physical quantities is two more than the number of base dimensions. By reason of it according to Buckingham's dimension analysis theory the problem can be described with two non-dimensional Π numbers,

$$\Pi_1 = g_0^{-1} R \left(\frac{l}{A} \right)^{-1}, \quad \Pi_2 = \frac{\sigma \rho}{\sigma_{BY} \rho_0},$$

there is a functionality between the two Π numbers:

$$\Pi_1 = f(\Pi_2) \rightarrow g_0^{-1} R \left(\frac{l}{A} \right)^{-1} = f \left(\frac{\sigma \rho}{\sigma_{BY} \rho_0} \right)$$

if we reduce the equation to the following form

$$R = g_0 f \left(\frac{\sigma \rho}{\sigma_{BY} \rho_0} \right) \frac{l}{A}$$

then it goes to show that the specific resistance of the chopped straw mass is

$$g = g_0 f \left(\frac{\sigma \rho}{\sigma_{BY} \rho_0} \right)$$

During the evaluation we described the $\frac{R}{\sigma \rho}$ quantity plotted against density and tension which is proportional with the

$$\frac{g}{\sigma \rho} \approx \frac{f \left(\frac{\sigma \rho}{\sigma_{BY} \rho_0} \right)}{\sigma \rho} \approx \frac{R}{\sigma \rho}$$

quantity. Figure 3 is goes to show that a status can be pointed out in every case, in which status the value of the specific resistance practically become stable. This means that from now on $\sigma \rho$ product becomes a linear function while previously the functionality was quadratic. The extract content does not influence the nature of the specific resistance changing but the

value of it. The break points of the curves are coincide with each other so with the applying of specific resistance the dominant effect of moisture content can be compensated.

Summary

The loading for the evolution of anaerob conditions can be determined with impedance measurement. During the elaboration of the method our hypothesis was that changing of the physical features follows the structure change of the mass. The stabilization of some physical feature shows the formation of the stable internal structure. In our opinion the examination of non-continuous changing of specific resistance is suitable for this purpose. We determined that the impedance of chopped straw silo-maize mass plotted against moisture content and density with constant capacitor coating distance but it does not change measurably during the sample relaxation. The capacitive reactance of the mass is negligibly small so we can substitute the measured impedance for ohmic resistance. We introduced the $\frac{R}{\sigma \rho}$ specific resistance that shows a clear break point

plotted against density and loading. Because the mass elements do not suffer further damage on this loading we reckon that the reason of the changing is the formation of the maximum joint surface of the fragments, so the evolution of the anaerob condition.

References

- [1.] CSERMELY J, SITKEI GY, FENYVESI L.: Mechanics and Energetics of the Pressing Processes. OTKA's final report, Sopron - Gödöllő, 1992. (Accessible: FVM Technical Insitute, Gödöllő.)
- [2.] FAVORODE M.O, O'CALLAGHAN J.R.: Rheological Model for the Compaction of Fibrous Agricultural Materials. Journal of Agricultural Engineering Research, 1989/42: 165-178.
- [3.] GELENCSEER E.: Analysis of the Effect of Tension Field for Compressing Mass of Chopped Green Forages with Model Tests. Phd dissertation, Gödöllő, 1997.
- [4.] SZENDRŐ P.: Chopping Green Forages. Publisher of the Academy, Budapest, 1995. p. 15-73.
- [5.] BENSE L.: Rheology of Chopped Silo-maize Masses. Phd dissertation, Gödöllő, 2001.

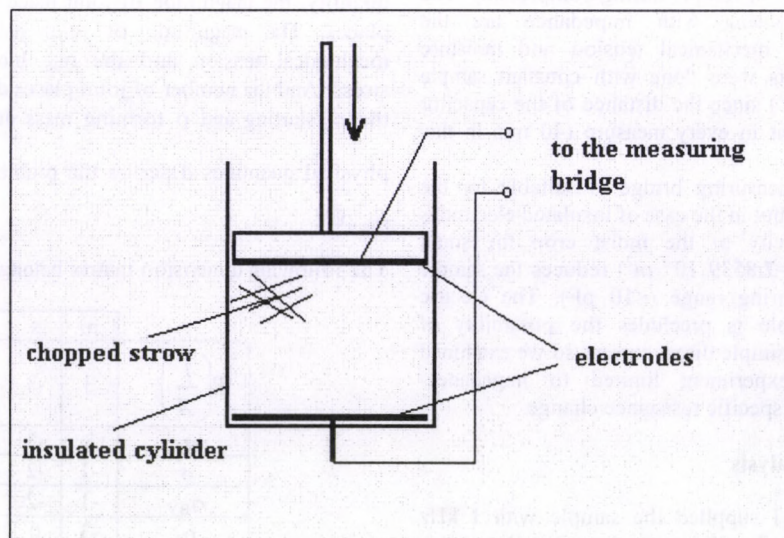

Figure 1 Insulated measuring cylinder for impedance measurement

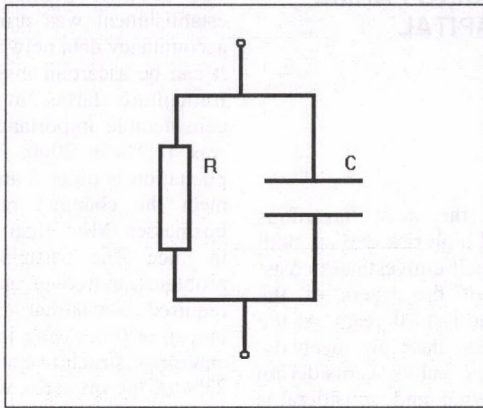

Figure 2 The electrical substitutive connection of the sample

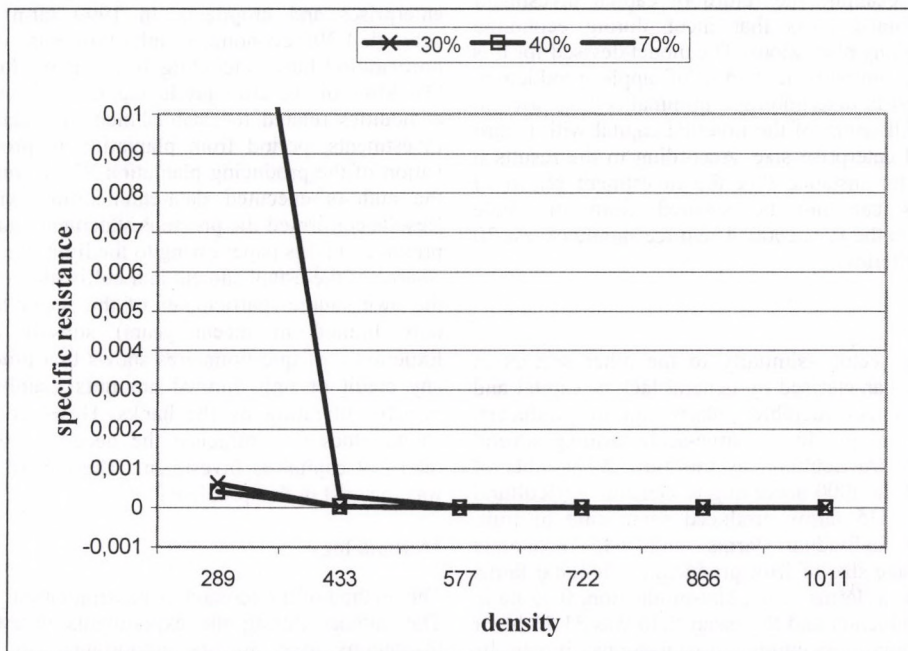

Figure 3 Changing of the specific resistance plotted against density and extract content

MODELLING OF FRUIT-PRODUCING FARMS WITH SPECIAL REGARD TO CAPITAL APPRAISAL OF INVESTMENT¹

Katalin Takács-György
Szent István University, Gödöllő

Abstract

Establishment of plantation sector is the most hazardous investment in agriculture. The associated high risk derives both from the long time span and the high specific investment costs. The fruit-producing sector was one of the losers of the economical and social changes during the last 10 years. At the same time the participant of the sector have to meet the requirements of ever changing consuming habits. Considering the high investment costs of fruit-growing and considerable current asset lockup of production-financing it is necessary to model examination of investment return in the sector. The aim of the study is to examine the return of capital investment increased by additional costs that incur during economic decisions of establishing plantations. The model devised for this purpose determines investment return of apple production. Furthermore, it helps in determining a minimal selling price to be achieved for a full return of the invested capital with regard to pre-set costs and enterprise size. According to the results it can be concluded for instance that the investment return of studied plantations can not be secured from the state procurement prices in the year 2000. The price should exceed 30 Ft/kg to meet this criterion.

Introduction

The fruit-producing sector –similarly to the other sectors in agriculture- can be characterised by general lack of capital and financial source and considerable polarisation of producers. Within the large-scale –previously large-scale farming several producer carried out fructiculture, by this time the number of them has multiplied. In 2000 according to General Agricultural Census (ÁMÖ) 143.415 farms produced some kind of fruit, including 142.770 individual farms and 645 economic organisations. Average size of fruit producing individual farms was 0.36 ha if there performs only plant-production, 0.05 ha in the case of joint production and the mean field was 31.25 ha or 12.79 ha in the case of economic organisations. It can be established according to data of AMÖ that farm-size cultivated by most of producers does not achieve the suitable size - the optimal size is 7-8 ha in the case of intensive fruit-production - which can provide safe livelihood of the owner and his/her family moreover it supplies satisfying annual income for simple reintroduction. At the same time advantageous trend can be observed: some of the owners seem to gain strength therefore they can attain considerable role in the economy owing to the

size of their plantation and produced output value. This establishment was proven by the data of farms in the farm accountancy data network [1].

It can be ascertain investigating the enterprise structure of the fructiculture farms in Hungary that the apple sector has considerable importance: its proportion in the cultivated area was 44,2% in 2000. However, nearly two third of the apple plantation is older than 20 years, the variety-structure does not meet the changed requirements of consumers and export businesses. More than 90% of the produced apple is processed to juice. The participants of the sector have serious sales problems, moreover machines, equipment and storage facilities required to post-harvest actions are absent. The high rate of industrial processing is not only owing to the disadvantageous enterprise structure but to the difficulties in marketing as well. 23% of the orchards were cultivated by companies, 19.4% by co-operations while the rest of the fields belonged to private producers in 1999. In 2000 25.1% of orchards were cultivated companies while 74.9% belonged to private producers (private enterprises and croppers). In 1999 farm accountancy data network 1.295 economical units took part, of which 134 were horticultural farms including 70 farms producing fruit (1.table) [3]. Most of the fruit producing farms have serious financial difficulties related to establishment of plantation and adjunct investments, period from plantation to production and cultivation of the producing plantation. Concerning to this problem the authors executed data-enumeration with questionnaires. Results confirmed the previous statement, but details can not be presented in this paper owing to the limit of size.

Source of the establishment and cultivation of plantation can be the own source (participants of the sector haven't got any or only limited in recent years) subsidy and bank credit. Experience of questionnaires shows that producers can not get any credit or only limited amounts mainly because of their insufficient rating by the banks. However the source of the capital does not influence the necessary of investigation of return of capital as investment. The aim of recent experiment was to assist in this problem.

Methodology

The method of the research is the simulation. The authors during the experiments investigated the apple-plantations due to its importance in the sector. For determination of the produced value and costs during lifetime of plantation, simulation model was developed which was suitable to answer the above mentioned questions. The financial sources of investments in the fruit-producing farms are required primary by costs of plantation-as investment costs (determined by the fruit species, variety and applied technology) and costs of cultivation till the turn to production of plantation in economical aspect².

Table 1 Data of horticultural enterprises (relative field size, income, result and equipment-value) by form of enterprises in 1999

| Terms | Proportion | Average field | Specific equipment-value | Specific income | Specific result by balance |
|---------------------------|------------|---------------|--------------------------|-----------------|----------------------------|
| | % | ha/farm | thousand Ft/ha | thousand Ft/ha | thousand Ft/ha |
| Cropper | 53.7 | 9.14 | 787.7 | 361.8 | 27.2 |
| Private entrepreneur | 27.6 | 36.91 | 609.1 | 194.3 | 42.2 |
| Deposit company | 4.5 | 54.00 | 532.3 | 175.7 | -37.1 |
| Limited liability company | 6.0 | 67.91 | 1.693.2 | 348.7 | 50.6 |
| Co-operation | 3.7 | 600.89 | 392.0 | 176.7 | 7.5 |
| Joint farms | 4.5 | 14.02 | 841.4 | 776.3 | 42.9 |
| Total | 100.0 | - | - | - | - |

Source: based on test-farm data by AKII, own collection

¹Based on oral presentation presented at MTA AMB XXV. Research and Development Meeting, 23-24th January 2001, supported by OTKA 32502 project

²Year of turn to production in economic aspect is that when the output value of the plantation exceeds the variable cost of cultivation for the first time, i.e. the value of annual gross margin contribution of the plantation turns into positive value.

At determination of initial condition of the model the base concept was elaborating of prospective income and cultivation elements related to different producing technology featuring the main decision making situation. The most questionable field of economical investigation of the plantation is the investment-profitability- and lifetime investigations. The authors have to pay attention during modelling to the fact that the production cycles are long-term, the effect of variety-choosing and decisions related to 'variety-portfolio' can be observed just afterwards therefore correction of the effects of occasionally bad decision can be carried out just later and with difficulties. Further problem is that the influence of decisions lasts long (production structure), the inelasticity of this sector exceeds far the other agricultural sector's therefore economic system functions this way can not respond to the changes of circumstances or can react just with making serious sacrifices [2].

During the development of the model the aim was that it should be suitable for calculating of fund contribution during the lifetime, rate of fund and threshold prices. In relation to the investment costs of mechanical system the authors supposed that some of the equipment exist in the farms, especially the power machines (*MTZ-82, New Holland 80-66, Zetor 9540*), therefore the required cost of investment is 6 million forint in addition to the cost of establishment of plantation. Owing to the limited size of this paper the authors disregard the description of the applied system.

The authors investigated the changes of the fund contribution during the lifetime of the apple plantation and return of the invested capital using a simulation model. This investigation was carried out based on the aggregated capital need of the equipment and the establishment of the plantation as well.

Results

During the modelling the authors investigated three plantation types, at which the gross margin always could be detected positive in the case of price of 30 Ft/ha. Beside the different costs of planting the authors examined how the capital return on the plantation change if the return of mechanical apparatus and adjunct investments are also an objective. Investigating the net present value it can be stated that return can not be provided at

10% calculative bank-rate in any variation. A reduction of the bank-rate (6%) resulted in positive return only in the case of M26 and less dense M9 type plantations (2 and 3 table).

Investigating the profit and the threshold-price it can be established that increase of the market price by 5 Ft at 10% bank-rate could provide a minimal profit for the producers over the return of invested capital in equipment.

As a conclusion it can be stated that the investigation on return of any capital investment has to be the basis of economic decision making right before the establishment of the plantation in order to bring a well-founded decision. At the same time we have to call the attention that results of the production strongly depend on marketing facilities of the sector and its market conditions. The subsidised 24 Ft/kg procurement price in 2000 does not provide positive return on any plantation scenarios studied therefore among unchanging conditions it is not worth to invest capital into this sector of the agriculture.

Conclusions

Investigations on return of investments as capital investments has to be carried out in advance of planting. The calculations considering the time span draws the attention to that beside the changes of consumers' demands and technological improvement we have to pay attention to the investigation of the solvent demand because small changes in the sales price can have a great influence on the managability of long-term decisions. The improvement of described decision making model can increase the accuracy of the planning process that has to be executed by all producers when they make economic decisions.

References

- [1.] J. BRAZSIL - S. SOMOGYI. Costs and return of investment in wine-grape plantation in hilly areas. *Georgikon for Agriculture. Bulletin of University of Veszprém* (under publication)
- [2.] Magyarország mezőgazdasága a 2000. évben Területi adatok. (AMÖ) KSH. Budapest. 2000. 581 p.
- [3.] Magyarország mezőgazdasága a 2000. évben Települési soros adatok. (AMÖ) KSH. Budapest. 2000. 479 p.
- [4.] TAKÁCSNÉ GYÖRGY K. A gyümölcsstermelő vállalkozások jellemzői. *Gazdálkodás*. XLIV. évf. 6. sz. Budapest. 2000. 37-43 p.

Table 2 Coefficient of net present value and return threshold price at 6% calculative bank rate

| Type of plantation | Investment costs | | During lifetime | | NPV (30 Ft/kg) | profit threshold price |
|---------------------------------|------------------|----------------------|-----------------|---------------------|-------------------|------------------------------|
| | machines | Costs of planting | Costs | production value | | |
| | (Thousand Ft) | (Thousand Ft) | (Thousand Ft) | (Thousand Ft) | (Thousand Ft) | (Ft/kg) |
| MM106 (7x4 m; 357 tree/ha) | 6.000 | 1.546.4 | 15.548.2 | 18.177.0 | -4.204.6 | 31.5 |
| M26 (5x2 m; 1000 tree/ha) | 6.000 | 3.280.2 | 14.448.5 | 19.110.0 | 5.379.1 | 28.5 |
| M9 (4x1 m; 2500 tree/ha) | 6.000 | 5.830.5 | 16.362.2 | 21.864.0 | 9.097.2 | 27.8 |
| M9 (3.8x0.7 m; 3500 tree/ha) | 6.000 | 6.830.9 | 20.806.0 | 24.309.0 | -7.211.0 | 31.6 |

Table 3 Coefficient of net present value and return threshold price at 10% calculative bank rate

| Type of plantation | Cost of capital construction | | During lifetime | | NPV (30 Ft/kg) | profit threshold price |
|---------------------------------|------------------------------|----------------------|-----------------|---------------------|-------------------|------------------------------|
| | machines | Costs of planting | Costs | production value | | |
| | (Thousand Ft) | (Thousand Ft) | (Thousand Ft) | (Thousand Ft) | (Thousand Ft) | (Ft/kg) |
| MM106 (7x4 m; 357 tree/ha) | 6.000 | 1.546.4 | 15.548.2 | 18.177.0 | -10.596.8 | 35.7 |
| M26 (5x2 m; 1000 tree/ha) | 6.000 | 3.280.2 | 14.448.5 | 19.110.0 | -5.122.4 | 32.1 |
| M9 (4x1 m; 2500 tree/ha) | 6.000 | 5.830.5 | 16.362.2 | 21.864.0 | -2.729.9 | 30.9 |
| M9 (3.8x0.7 m; 3500 tree/ha) | 6.000 | 6.830.9 | 20.806.0 | 24.309.0 | -17.033.7 | 35.2 |

INVESTIGATION OF THE BINDING AND DIFFUSION ENERGY OF WATER IN YEAST (SACCHAROMYCES CEREVISIAE)
(OTKA T 032666)

M. Neményi, University of West-Hungary
L. Bercz, Process Engineering of Agricultural Products,
Research Group of the Hungarian Academy of Sciences

There are many reports in the literature dealing with the binding energetics of water in foodstuff, such as yeast. The methods used to calculate the binding energy are based on the analysis of sorption isotherms and application of the Clausius-Clapeyron equation. However, the reported values agree slightly. As a new method, in this study the energy balance of the drying was established by means of moist air state equations, then the energy needed for binding and diffusion of water was calculated in dynamic conditions. The experiments were carried out in a PC-controlled drying tunnel. The temperature of inlet air was 45 °C and the air velocity was 0.3 ms⁻¹. The layer thickness was chosen as 1.9, 2.3, 2.6, 4.1 and 4.9 mm.

Introduction

Binding energy is the heat needed to remove water from the materials. Sorption isotherms and isosteres are widely used for the calculation of binding energy of water in biological materials. The method means determination of binding energy under static conditions using the Clausius-Clapeyron equation, reported by several authors [1, 2, 3, 4, 5, 6].

In this study a new approach is reported. We assumed that enthalpy loss of drying air due to the break down of binding of water could be measurable. The enthalpy loss should be appear in the energy balance of drying.

Energy balance for drying air:

$$\Phi_{in} + \Phi_{mo} = \Phi_{out} + \Phi_{loss} + \Phi_c \quad (1)$$

where Φ_{in} is the enthalpy flow of inlet air (kJ s⁻¹); Φ_{mo} is the enthalpy flow of moisture evaporated from the material into the drying air; Φ_{out} is the enthalpy flow of outlet air; Φ_{loss} is the enthalpy flow of heat losses throughout the drying tunnel; Φ_c is the convective enthalpy flow transferred to the material.

Assuming adiabatic conditions (perfectly isolated system, $\Phi_{loss}=0$) and free evaporating water surface in the tunnel:

$$\Phi_c = \Phi_{mo} \quad (2)$$

In reality, a material to be dried is situated in the tunnel. In this case Φ_c covers

- the enthalpy needed for heating the material (Φ_h),
- the enthalpy needed for releasing the bound water and for its diffusion inside the material (Φ_{bd}),
- the enthalpy needed for evaporating the water(Φ_{mo}).

$$\Phi_c = \Phi_h + \Phi_{bd} + \Phi_{mo} \quad (3)$$

For Φ_{bd} we obtain from equations 1 and 3

$$\Phi_{bd} = \Phi_{in} - \Phi_{out} - (\Phi_{loss} + \Phi_h) = L(h_{in} - h_{out}) - (\Phi_{loss} + \Phi_h) \quad (4)$$

where h_{in} and h_{out} are the specific enthalpy of inlet and outlet air (kJ/1+y) and L is the (dry) mass flow of drying air (kg s⁻¹).

The enthalpy transferred by water from the material into the air is considered as zero.

See the schematic Mollier h-y chart on Fig. 1. Enthalpy (h , kJ kg⁻¹) and temperature (t , °C) of moist air is on the ordinate, absolute humidity (y , kg kg⁻¹) is on the abscissa.

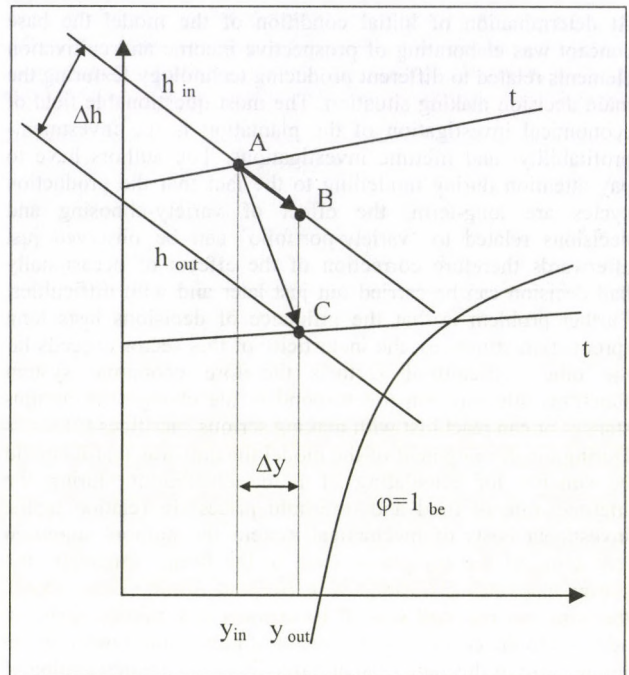

Figure 1 The h-y chart of the moist air

Saturated relative humidity curve ($\varphi=1$) is also presented. The moist drying air entering into the drying tunnel has h_{in} enthalpy, t temperature and y_{in} absolute humidity (point A). The state of outlet drying air is characterized by point B under adiabatic conditions, according to the equation 2. Under real conditions (equation 3) the state of outlet moist drying air identical to point C has h_{out} enthalpy, t_{out} temperature and y_{out} absolute humidity. If the mass flow of the evaporated water is M (kg s⁻¹) then:

$$L = \frac{M}{y_{in} - y_{out}} \quad (5)$$

According to equations 4 and 5:

$$\frac{\Phi_{bd}}{M} = \frac{h_{in} - h_{out}}{y_{in} - y_{out}} - \left(\frac{\Phi_{loss} + \Phi_h}{M} \right) \quad (6)$$

Φ_{loss} was determined by measuring the drying air temperature in 25 points of the cross-sectional area at inlet and outlet sides of the tunnel, without a sample. Falling of drying temperature was 1.9 °C on $t_{in} = 45$ °C temperature and $v=0.3$ m s⁻¹ air velocity by which measured values of air enthalpy were corrected.

Φ_h was determined from the well known equation:

$$\dot{Q}_m = c_m m dt \quad (7)$$

where \dot{Q}_m is the enthalpy, m mass, dt temperature change. The c_m specific heat was determined as follows [7]:

$$c_m = 2.7 + 0.00357 X_m \quad (8)$$

where X_m is the moisture content of the material on dry basis.

Materials and methods

Experiments were carried out in a PC-controlled drying tunnel at the laboratory of the Institute of Agricultural, Food and Environmental Engineering, Mosonmagyaróvár. Inlet air temperature was 45°C and air velocity was 0.3 m s⁻¹. Layer thickness was provided as 1.9, 2.3, 2.6, 4.1 and 4.9 mm.

The investigated material was commercially available compressed yeast, initial moisture content X_i was between 190 és 230% on dry basis.

Results and discussion

Introducing E_{bd} instead of the Φ_{bd}/M expression, the E_{bd} is plotted against moisture content (calculated on dry basis) at different layer thicknesses in Fig.2. ($t_{in}=45\text{ }^\circ\text{C}$; $X_{in}=0.01075\text{ kg kg}^{-1}$; $v=0.3\text{ m s}^{-1}$)

The E_{bd} designates the energy needed for unbinding and diffusion of a unit mass of water inside the material. Moisture content has no effect on the E_{bd} at a moisture content higher than 40%, but the higher the layer thickness the higher the E_{bd} . It comes from the known law for conduction where the flow magnitude is in inverse proportion to the length of the conductor.

Increasing slope of E_{bd} between 7 and 40% moisture content indicates clearly the change of the binding state of water. There are no plotted values under 7% moisture content because under experimental conditions an equilibrium reached between drying air and the material. E_{bd} of lower moisture contents could be explored by reducing X_{in} absolute air humidity.

E_{bd} is plotted as a function of layer thickness on Fig. 3 at different moisture contents. The higher the layer thickness the higher the E_{bd} because of the increasing amount of energy needed for diffusion. The net binding energy can be determined by extrapolating the curves to lower layer thickness than 2 mm and localizing crossing points on the ordinate. For this purpose linear fitting was done. Obtained values are plotted on Fig 4.

In Fig. 4. other data (a, b) from the literature are also shown concerning the binding energy of the *Saccharomyces cerevisiae* based yeast [1, 2]. They are issued from the theory using sorption isotherms and the Clausius-Clapeyron equation. Equilibrium moisture content X_e of the material is also

presented (7%) which forms an asymptote of the triangle-marked curve. The net binding energy values reported in this study are multiples rather than those coming from the literature between 7 and 20% moisture content. The net binding energy under 7% can be calculated by our method using drying air with zero absolute humidity. The actual asymptote is assumed to be simply shifted toward the ordinate.

References

- [1.] IGLÉSIAS, H. A.; CHIRIFE, J.; FONTAN, C. F (1989). On the temperature dependence of isosteric heats of water sorption in dehydrated foods. J. of Food Science, Vol. 54, No. 6, 1989, p. 1620-1623
- [2.] KOGA, S.; ECHIGO, A.; NUNOMURA, K. (1966). Dphysical properties of cell water in partially dried *Saccharomyces cerevisiae*. Biophysical Journal Vol.6 (1966) 665-674
- [3.] SEIDL G. (1967). Porózus vagy kolloid közegben kötött nedvesség kötési energiájának néhány kérdése. Magyar Kémikusok Lapja 1967. 5.sz. 245-249
- [4.] SOEKARTO, S. T.; STEINBERG, M. P (1981). Determination of binding energy for the three fraction of bound water. In Water activity: influences on food quality. Edit. By L. Rockland and G. F. Stewart, Academic Press, 1981
- [5.] TOLABA, M. P.; SUÁREZ, C.; VIOLLAZ, P (1997). Heats and entropies of sorption of cereal grains: a comparison between integral and differential quantities. Drying Technology, 15 (1), 137-150 (1997)
- [6.] TSAMI, E.; MAROULIS, Z. B.; MARINOS-KOURIS, D.; SARAVACOS, G. D. (1990). Heat of sorption of water in dried fruits. Internat. J. Food Sci. and Technol., 25, 350-359 (1990)
- [7.] VOLOBUEVA, L. N.; BOCSAROVA, G. A.; SISACKIJ, J. I. (1974). Iszledovanie teplofiziceszkih szvoisztv blazsnüh khlebopekarnüh drozzsej. Piscsevaja Tekhnologia No. 3 (1974): 105-107.

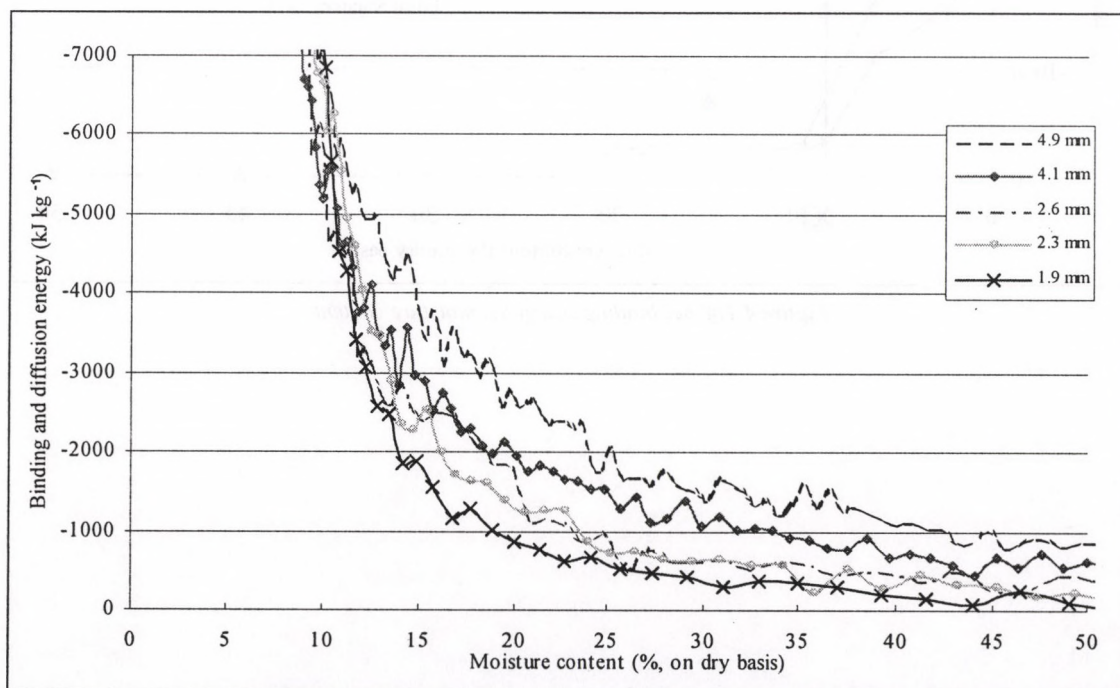

Figure 2 E_{bd} vs. moisture content at different layer thicknesses

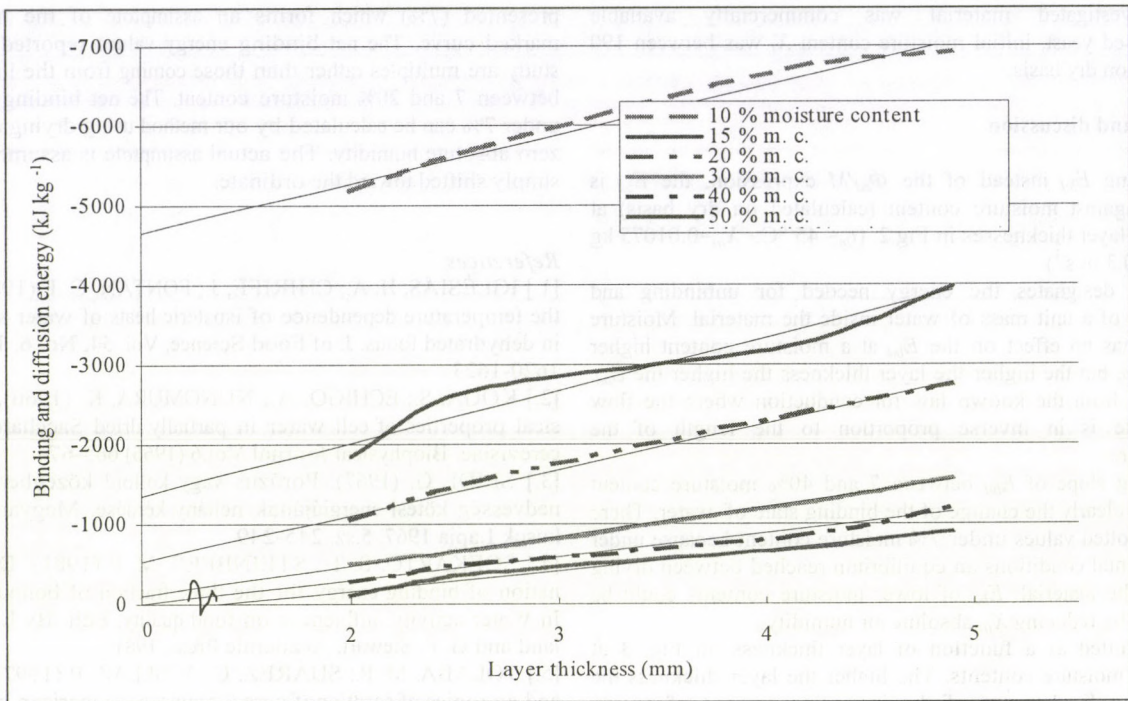

Figure 3 E_{bd} vs. layer thickness at different moisture content

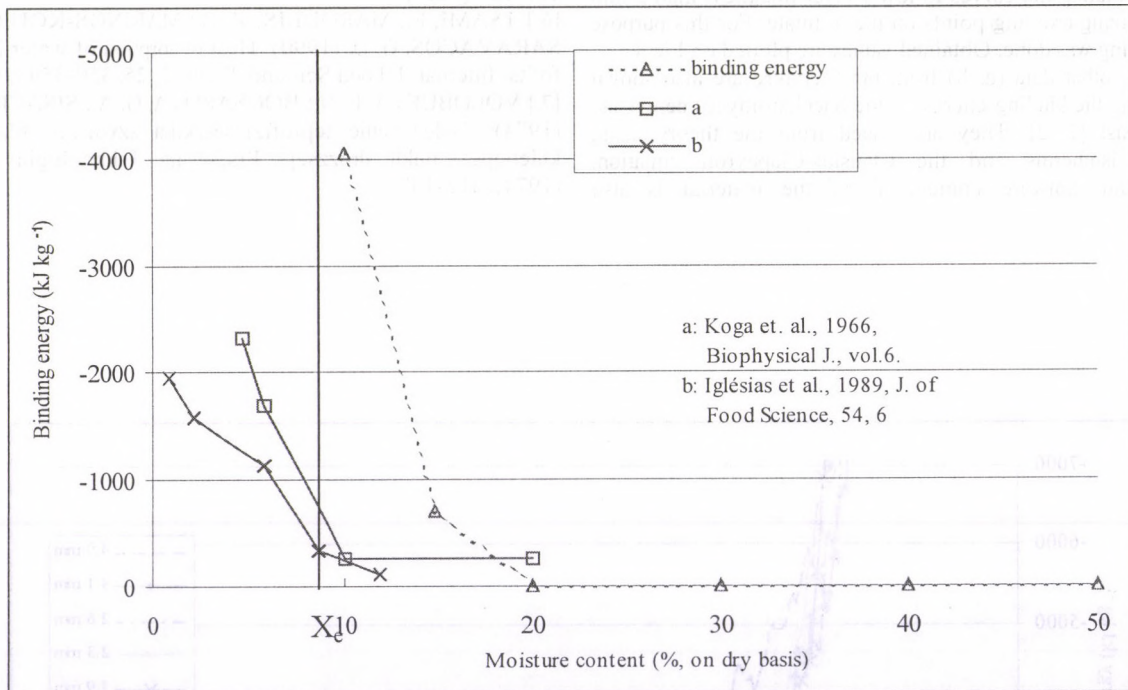

Figure 4 The net binding energy vs. moisture content

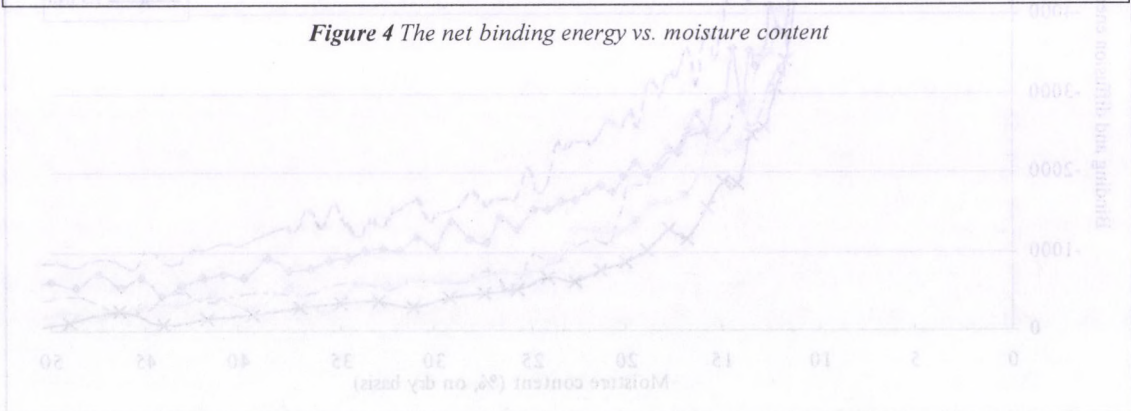

Figure 5 E_{bd} vs. moisture content at different layer thicknesses

THE INFLUENCE OF ROOT SYSTEM ON SOIL RESISTANCE

B. Horváth - T. Major
University of West Hungary, Sopron

Summary

Establishment of the computer soil - model that is really difficult in modelling soil - machine correlation. Modelling the machinery is relatively simple knowing the structural parameters and the material characteristics. The description of the mechanical properties of the soil and the description of its regularity is really a difficult job since its complicated structural construction and its inhomogeneity. An additional difficulty may occur in our forests as far as stumped and rooted lands are concerned. The occurrence of roots may increase the solidification of the soil. (The increment even can be 50-70 %). This thesis was designed to find the proper answer how soil resistance changes -influenced by the root system in the correlation with tree species, diameter and distance from the tree.

Introduction

Analysis of machinery applied in soil cultivation, description of theoretical issues may provide suitable information for those who are involved in development of forest machinery and for operators. This is an efficient method to get over the difficulties of ongoing operation of machinery and to facilitate the process of the application of new machinery.

Testing and evaluation techniques give balanced picture of serviceability of the particular machinery, the quality of the operation, the possible defects, design shortcomings. Experimental and testing findings and outcomes provide good basis to make further developments drafting or designing new equipment or upgrading the existing ones.

Theoretical knowledge makes it possible to develop perfect awareness for operators of machinery and equipment in connection with the size, minute per revolution, pulling power, driving power, lay out and other technical parameters required in order to carry out efficient and cost effective performance.

One of the possible ways of testing is modelling of soil - machine correlation. This testing procedure is available with computer aided modelling programmes.

Establishment of the computer soil - model that is really difficult in modelling soil - machine correlation. Modelling the machinery is relatively simple knowing the structural parameters and the material characteristics.

The description of the mechanical properties of the soil and the description of its regularity is really a difficult job since its complicated structural construction and its inhomogeneity.

In SITKEI'S (1986) opinion the most significant characteristics of soil are as follows:

- load - bearing capacity, its modification depending on depth
- bulk density or (ratio of pore)
- moisture content
- cohesion
- internal friction coefficient
- shear deformation coefficient
- stress consolidation
- viscoelastic properties
- thixotropic properties

An additional difficulty may occur in our forests as far as stumped and rooted lands are concerned. Presence of satisfactory root system can increase soil density with even 50- 70 %.

This presentation was designed to find the proper answer how soil resistance changes on the influence of root system.

Material and method

Experimental testing of soil resistance was carried out by electronic layer indicator. (3T System). The equipment is to be manually handled. It is suitable in 1 cm layer detecting moisture content and density of the soil. Soil moisture content and farmland water-capacity (pF 2,5) % is described in % as a share of volume. Soil penetration is registered with a measuring cone (60 degree, 12,5 mm diameter). Resistance of soil penetration is measured in kPa. Measured data are recorded and can be evaluated with computers. Application of the measuring device requires the knowledge of the clay content of the measuring field. Relevant clay content code should be adjusted on the measuring device prior to its application.

Measurements were carried out in the forest subcompartment 91/ B Sopron. This subcompartment belongs to the Sopron Forestry Ltd., which is also an experimental compartment of the Institute of Forest Management of the University of West Hungary.

The most significant properties of the forest sub compartment: Soil-properties:

- Genetic soil type: lessivated brown forest soil
- Physical properties : clayey soil , loamy clay (Ka:47)
- Hydrologic properties: independent from surplus water supply
- Thickness of soil : ME

Tree stand properties:

- Mixed stand (sessile oak , spruce , larch, hornbeam)
- Age: 89
- Average diameter at breast height : 36 cm
- Stem number per hectare: 370 pieces

In the experimental forest subcompartment each of the trees is registered with the most efficient pieces of information: tree species, co-ordinate, age, diameter at breast height etc.

The experimental forest subcompartment has also been mapped so follow up testing and reconstruction is also available.

In the course of the investigation we desperately wanted to find how soil resistance changes influenced by the factors like tree species, diameter and distance from the tree. The experiment was designed that way: in the subcompartment diameter-interval was covered. (Since in forest economy diameter at breast height is applied, we did the same. (With the application of tables stem and diameter at breast height can be converted.) In concentric cycles around the selected trees soil resistance were registered in every 0,5 m. up to three meters. It is not worth measuring soil resistance in greater distance since- due to the data of stem number registration- we are aware of the fact that other tree species influence is involved in such a distance. Sessile oak species were measured. As further objective other species should be tested. Depth of our measurement was 40 cm. Soil cultivation is implemented in such a depths as well, and most of the root system is available in this particular depths. According to the professional literature length of root system is mostly available in 65-85 % in the top 10 cm of the soil.

Results and conclusion

According to the results of the measuring activity we can come across to the conclusion: in 1-1,5 m neighbouring area around the tree is the very place where root system increases soil resistance. In the lack of control area we do not know what the soil resistance figures are farther than 1,5 m and What the figures are in case of soil without root system, or other soils with the same parameters. In case of trees less than 30 cm diameter at breast height influence of root system could not be displayed. Specimen with bigger diameter did not always prove the case as a matter of fact. Open grown species succeeded to

prove our proposal without any doubt. 370 pieces / ha stem number referring to one tree with radius of 3 m theoretical growing space as a result of accidental disposition of the trees sometimes a lot less. (influence of neighbouring trees) In such places or in case of bigger stem number per hectare root systems covers the soil of the subcompartment in an even way so soil resistance is relatively even as well.

Definition of the function of correlation of soil resistance and diameter has not been carried out yet. On the other hand findings and outcomes of our measuring activities proves the existence of correlation. (1. Figure). A larger number of measurement is required since root system is individually very sporadic.

Soil resistance shows a relatively standard value in the top 40 cm layer except for the top humic soil.

Evaluation was done based on an impressive number of measurements. There is a very big coefficient of variation of the

measurements. Accuracy of measuring was endangered by rocks in the soil layer and presence of roots left from former forest logging operations.

References

[1.] HORVÁTH, B. - MOUAZEN, A.M. - NEMÉNYI M. (1998): Investigation of Forestry Deep Subsoiling by the Finite Element Method. Hungarian Agricultural Engineering.11:47-49
 [2.] MIHÁLY, S. (1993): Damages Done by Tree Harvesting, Possibilities of Environmental Friendly Tree Harvesting PhD Thesis, Sopron.
 [3.] SITKEI, GY.: (1967) Soil mechanical Problems of Forest Machines. Akadémiai Kiadó, Budapest
 [4.] SITKEI, GY.: (1986): Modelling Agricultural and Forest Vehicles. Akadémiai Kiadó, Budapest.

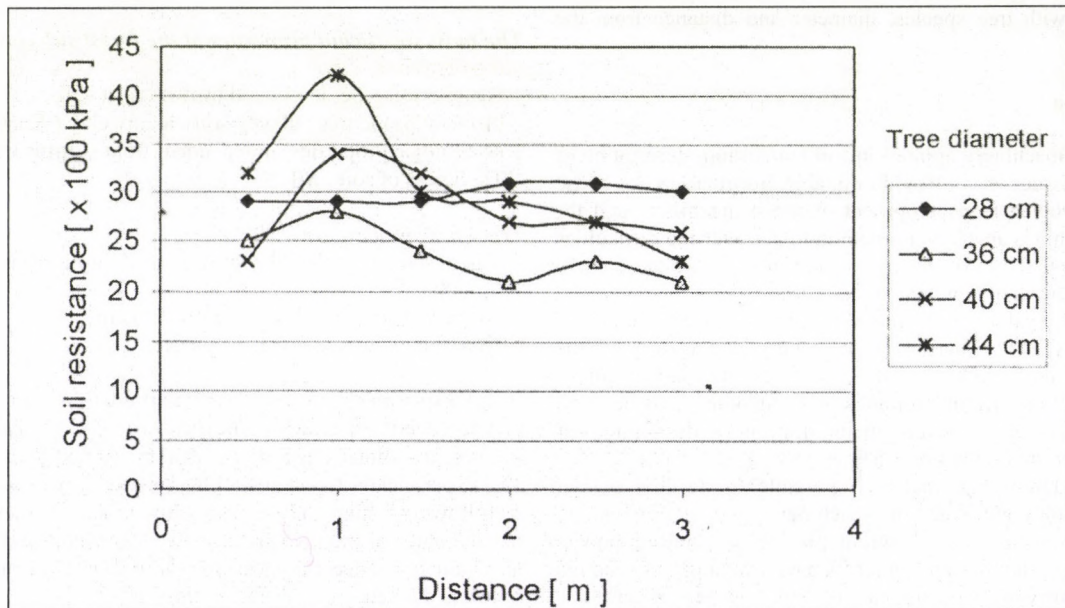

Figure 1 Influence of root system on soil resistance

FIXED BED DRYING CHARACTERISTICS OF YEAST (*Saccharomyces cerevisiae*) IN DIFFERENT LAYER THICKNESS

(OTKA T 032666)

L. BERECZ

Process Engineering of Agricultural Products, Research Group of the Hungarian Academy of Sciences

M. NEMÉNYI

University of West-Hungary

Drying characteristics of beer yeast were investigated in a convective drying tunnel in order to establish the function between the drying time and moisture content. The drying curve was described as

$$\frac{X - X_e}{X_0 - X_e} = \exp(-K\tau)$$

where: X moisture content on dry basis, K drying constant, τ time. Indices 0 and e designate the initial and equilibrium states, respectively.

Inlet air temperature was chosen as 40 °C, 45 °C and 50 °C as we determined from our previous investigations [1, 2]. The layer thicknesses were 1 mm, 2.1 mm (only on 45°C and 50°C), 3 mm and 5 mm, inlet air velocities were 0.5, 1.3 and 2 ms⁻¹. The K drying constant was determined as a function of the temperature and the layer thickness. The equation obtained contributes to the planning of yeast drying processes.

Introduction

There are two ways to describe drying processes, namely the methods using concentrated parameters and divided parameters. The method with divided parameters means to determine and solve differential equations for simultaneous heat and mass transfer. In the other case, the moisture content (concentrated parameter) is expressed as a function of the time.

We chose the latter method for describing the drying process because of its practical importance. In an earlier paper by us [1] a study was reported on the effect of the drying air temperature, air velocity and relative humidity of inlet air on the drying kinetics of *Saccharomyces cerevisiae* based yeast.

The governing equation:

$$\frac{X - X_e}{X_0 - X_e} = \exp(-K\tau) \quad (1)$$

where: X moisture content on dry basis, K drying constant, τ time. Indices 0 and e designate the initial and equilibrium states, respectively.

The drying constant can be expressed as a function of moisture diffusivity. For slabs the following equation is valid:

$$K = \frac{\pi^2 D}{L^2} \quad (2)$$

where D (m² s⁻¹) is the effective diffusivity and L (m) is the thickness of the slab.

A comprehensive compilation of drying constants and moisture effective diffusivities of different biological materials was reported by D. Marinos Kouris et al. [3]. Diffusivities in foods had values in the range 10⁻¹³ m² s⁻¹ to 10⁻⁶ and most of them accumulated in the region 10⁻¹¹ to 10⁻⁸.

Luyben et al. [4] determined the diffusivity of different foods (coffee, skim milk, apple, potato) on the basis of drying curves. Their values ranged between 10⁻⁵ and 10⁻² (coffee), 10⁻¹¹ and 10⁻⁹

(skim milk), 10⁻¹¹ and 10⁻⁸ (apple), 10⁻¹¹ and 10⁻⁹ (potato, all of them in m² s⁻¹). They emphasized that effective diffusivity can contain several effects (liquid and vapor diffusion, capillary flow, evaporation-condensation etc.) and can not be interpreted as molecular diffusion coefficient. They paid special attention to the shrinkage phenomena also.

Neményi [5] investigated the effective diffusivity among other drying characteristics of several corn hybrids. He found that the diffusivity was proportional to the energy needed for moisture removal and useful for ranking corn hybrids from the point of view of drying energetics. The diffusivity ranged between 2.17×10⁻¹¹ and 87.32×10⁻¹¹ m² s⁻¹.

Materials and methods

Experiments were carried out in a PC-controlled drying tunnel at the research laboratory of the Institute of Agricultural, Food and Environmental Engineering, Mosonmagyaróvár, Fig. 1. The air velocity in the tunnel could be set between 0.3 and 2.5 m s⁻¹, and air temperature between ambient temperature and 90°C. The surface temperature of the material to be dried was measured by an optic (infrared) thermometer. The cross-sectional area of the tunnel was 0.18×0.18 m². The body of the tunnel was isolated by a coat of polystyrene foam, thickness = 0.06 m. The process control programme was created using the LABView software.

The material to be dried was commercial compressed beer yeast, its initial moisture content (X_i) varied between 190 and 230% on dry basis. The inlet air temperature was chosen as 40, 45 and 50°C, and the air velocity was 0.5, 1, 3 and 2 ms⁻¹. Drying characteristics were investigated at four layer thicknesses: 1, 2.1 (only on 45°C and 50°C), 3 and 5 mm. The yeast samples were disc shaped with 50 mm diameter.

Results and discussion

The K drying constant as a function of the layer thickness and the air velocity is presented in Fig. 2 and Fig. 3. Obtained values of K were between 0.4459×10⁻⁴ and 5.5652×10⁻⁴ sec⁻¹. It is obvious that an increasing in temperature was accompanied by the increase of K values. The layer thickness thinner than 3 mm considerably affected the factor K while at thicker layers this effect was almost negligible.

Increasing the air velocity from 1.3 to 2 ms⁻¹ resulted in a smaller effect on drying kinetics at a layer thickness above 2.1 mm than below 2.1 mm. Measured K values were smaller at air velocity of 0.5 m s⁻¹ than in the case of 1.3 and 2 ms⁻¹. The abrupt change of K between 1 és 3 mm could be due to the formation of a crust on the surface of the material.

Measured values of drying constant and effective diffusion coefficients are presented in Table 1, 2 and 3 as a function of the drying temperature, layer thickness and air velocity. They show consistency with the literature.

Conclusions

Drying curves can be generated and drying time can be predicted if the relation between K drying factor and drying parameters (air velocity, inlet air temperature, layer thickness) is known. In this case the processing time can be calculated on the basis of the initial moisture content.

References

- [1.] BERECZ, L., NEMÉNYI, M. (1998). Convective drying simulation of *Saccharomyces cerevisiae* biomass using Simulink. IFAC/ISHS/CIGR/EURAGENG 2nd International Workshop on Control Applications in Post-harvest and Processing Technology. Budapest, Hungary, June 3-5, 1988. pp.159-161

[2.] BEREZ, L.; NEMÉNYI, M; PUIGGALI, J. R. (1999). Combined microwave-convective drying of *Saccharomyces cerevisiae* based yeast. *Acta Alimentaria*, Vol. 28 (3), pp. 223-233
 [3.] Handbook of Industrial Drying. Ed. A.S. Mujumdar, 2nd Expanded Edition. Marcel Dekker, New York. 1995. 1424 pp.
 [4.] LUYBEN, K. CH. A. M.; OLIEMAN, J. J.; BRUIN, S. (1980). Concentration dependent diffusion coefficients derived

from experimental drying curves. in *Drying '80* Vol. 2 Ed. by A. S. Mujumdar, Hemisphere Publ. Co., Washington-Newyork-London, 1980 pp. 233-243
 [5.] NEMÉNYI, M. (1983). Improving of energy balance of corn production with special regards to the factors influencing the heat consumptions of grain drying. PhD Thesis, Mosonmagyaróvár, 1983 (in Hungarian)

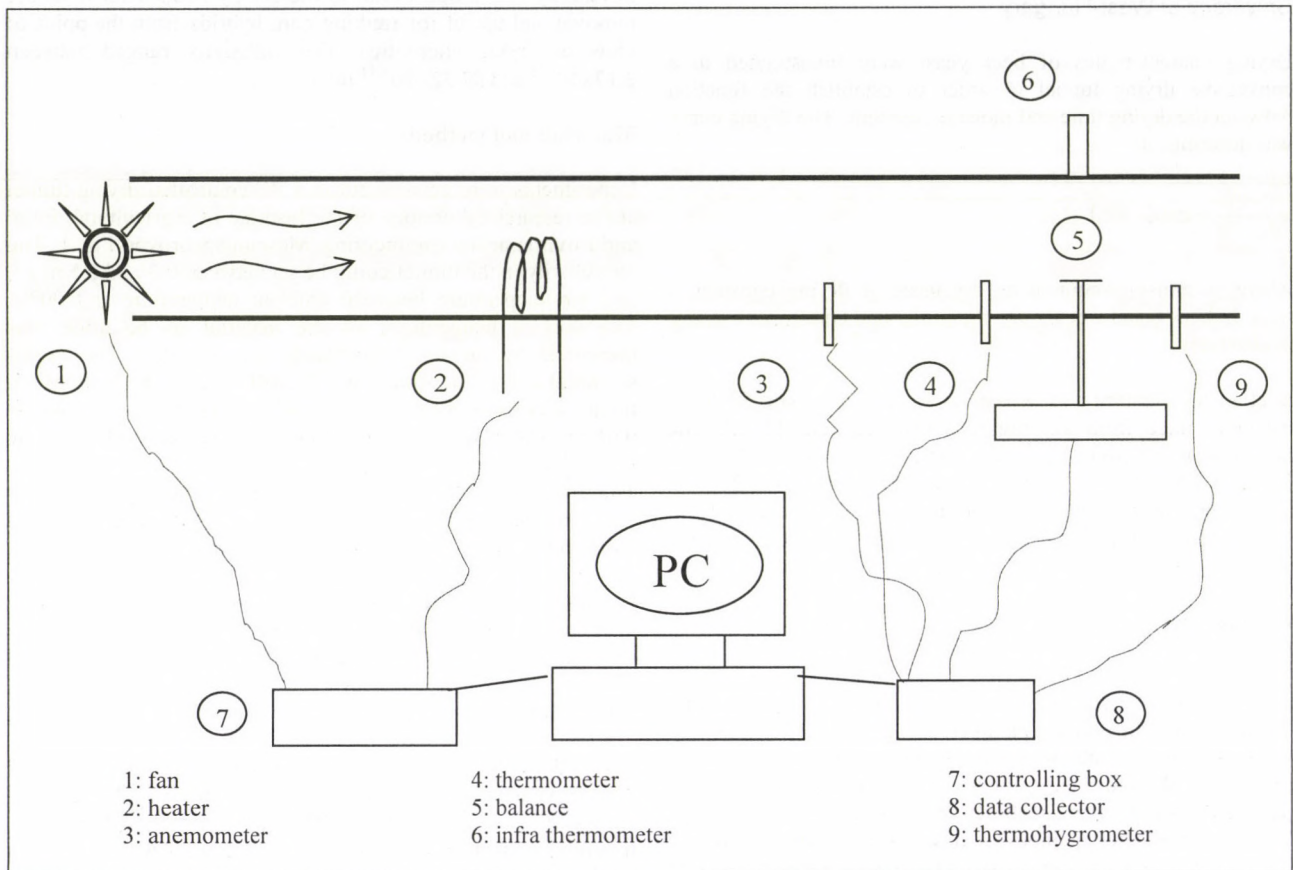

Figure 1 Experimental drying tunnel

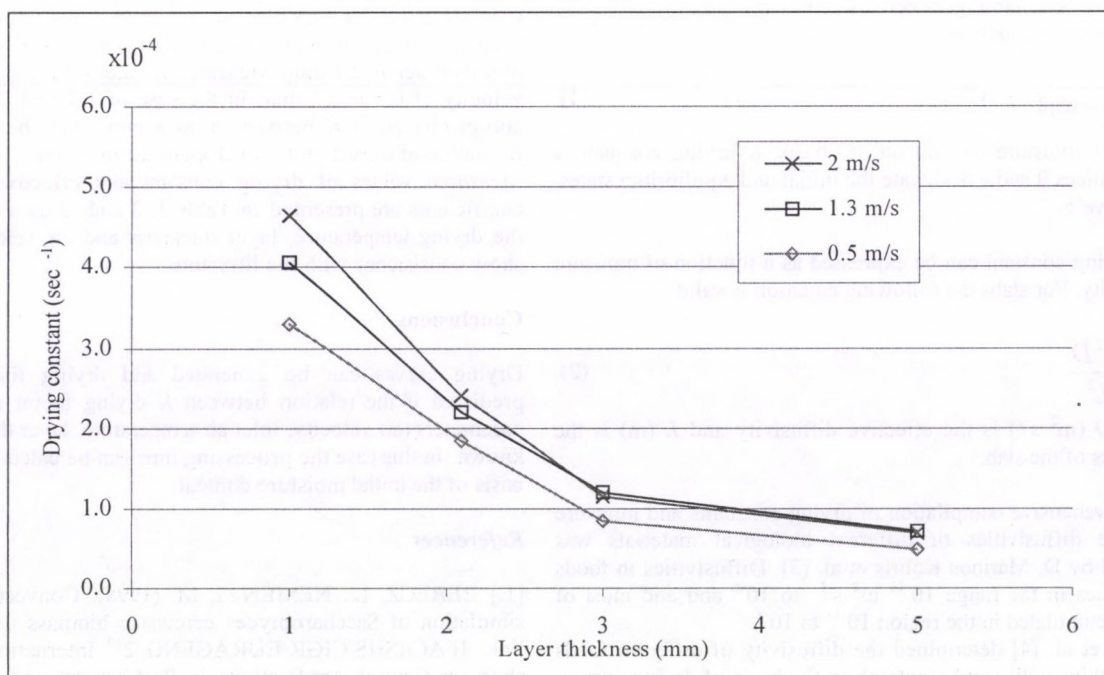

Figure 2 The K drying constant as a function of the layer thickness and air velocity on 45 °C

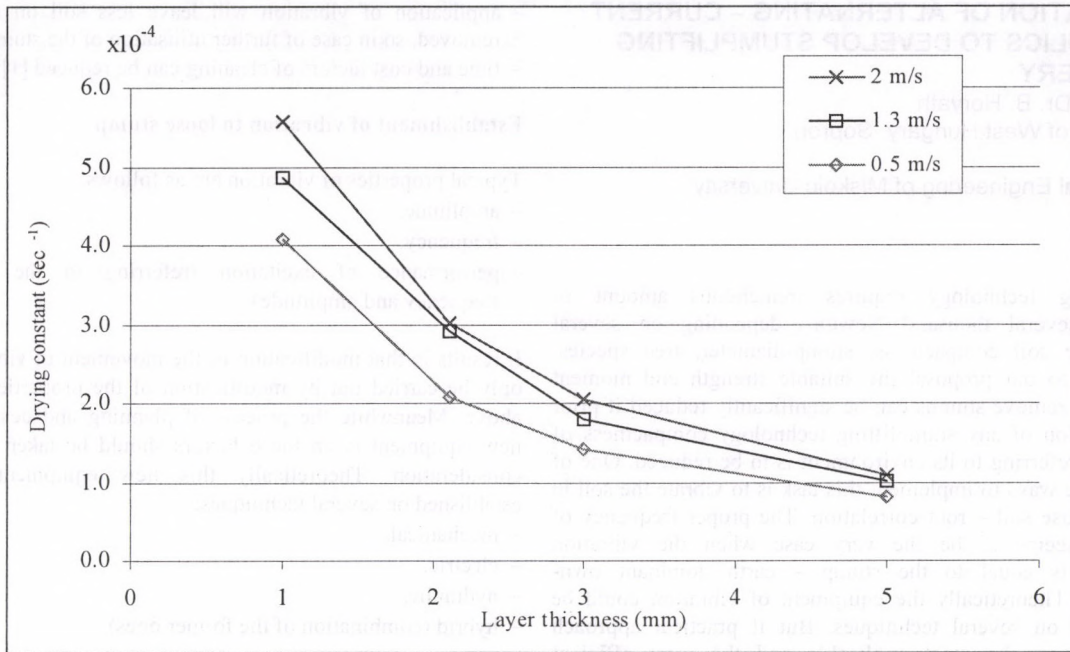

Figure 3 The K drying constant as a function of the layer thickness and air velocity on 50 °C

Table 1 K drying constants and D diffusion constants on 40°C

| K (sec ⁻¹) D (m ² sec ⁻¹) | | Air velocity (m s ⁻¹) | | |
|---|-------|---|---|---|
| | | 0.5 | 1.3 | 2 |
| Layer thickness (m) | 0.001 | K: 2.7002×10 ⁻⁴ D: 2.7386×10 ⁻¹¹ | K: 3.7163×10 ⁻⁴ D: 3.7692×10 ⁻¹¹ | K: 2.6397×10 ⁻⁴ D: 2.6772×10 ⁻¹¹ |
| | 0.003 | K: 0.7896×10 ⁻⁴ D: 7.2078×10 ⁻¹¹ | K: 1.1298×10 ⁻⁴ D: 1.0313×10 ⁻¹⁰ | K: 1.2192×10 ⁻⁴ D: 1.1129×10 ⁻¹⁰ |
| | 0.005 | K: 0.4459×10 ⁻⁴ D: 1.1305×10 ⁻¹⁰ | K: 0.6505×10 ⁻⁴ D: 1.6493×10 ⁻¹⁰ | K: 0.7220×10 ⁻⁴ D: 1.8308×10 ⁻¹⁰ |

Table 2 K drying constants and D diffusion constants on 45°C

| K (sec ⁻¹) D (m ² sec ⁻¹) | | Air velocity (m s ⁻¹) | | |
|---|--------|---|---|---|
| | | 0.5 | 1.3 | 2 |
| Layer thickness (m) | 0.001 | K: 3.2836×10 ⁻⁴ D: 3.3304×10 ⁻¹¹ | K: 4.0642×10 ⁻⁴ D: 4.1221×10 ⁻¹¹ | K: 4.6465×10 ⁻⁴ D: 4.7126×10 ⁻¹¹ |
| | 0.0021 | K: 1.8346×10 ⁻⁴ D: 8.2058×10 ⁻¹¹ | K: 2.2080×10 ⁻⁴ D: 9.8761×10 ⁻¹¹ | K: 2.3876×10 ⁻⁴ D: 1.0679×10 ⁻¹⁰ |
| | 0.003 | K: 0.8526×10 ⁻⁴ D: 7.7822×10 ⁻¹¹ | K: 1.1963×10 ⁻⁴ D: 1.0920×10 ⁻¹⁰ | K: 1.1538×10 ⁻⁴ D: 1.0532×10 ⁻¹⁰ |
| | 0.005 | K: 0.4938×10 ⁻⁴ D: 1.2521×10 ⁻¹⁰ | K: 0.7125×10 ⁻⁴ D: 1.8066×10 ⁻¹⁰ | K: 0.6841×10 ⁻⁴ D: 1.7347×10 ⁻¹⁰ |

Table 3 K drying constants and D diffusion constants on 50°C

| K (sec ⁻¹) D (m ² sec ⁻¹) | | Air velocity (m s ⁻¹) | | |
|---|-----|---|---|---|
| | | 0.5 | 1.3 | 2 |
| Layer thickness (m) | 1 | K: 4.0702×10 ⁻⁴ D: 4.1282×10 ⁻¹¹ | K: 4.8490×10 ⁻⁴ D: 4.9180×10 ⁻¹¹ | K: 5.5652×10 ⁻⁴ D: 5.6444×10 ⁻¹¹ |
| | 2.1 | K: 2.0867×10 ⁻⁴ D: 9.3335×10 ⁻¹¹ | K: 2.8995×10 ⁻⁴ D: 1.2969×10 ⁻¹⁰ | K: 3.0040×10 ⁻⁴ D: 1.3436×10 ⁻¹⁰ |
| | 3 | K: 1.4073×10 ⁻⁴ D: 1.2846×10 ⁻¹⁰ | K: 1.7947×10 ⁻⁴ D: 1.6383×10 ⁻¹⁰ | K: 2.0526×10 ⁻⁴ D: 1.8736×10 ⁻¹⁰ |
| | 5 | K: 0.8100×10 ⁻⁴ D: 2.0538×10 ⁻¹⁰ | K: 1.0104×10 ⁻⁴ D: 2.5619×10 ⁻¹⁰ | K: 1.0805×10 ⁻⁴ D: 2.7397×10 ⁻¹⁰ |

APPLICATION OF ALTERNATING – CURRENT HYDRAULICS TO DEVELOP STUMLIFTING MACHINERY

I. Czupy - Dr. B. Horváth
University of West Hungary, Sopron
J. Lukács
Mechanical Engineering of Miskolc University

Summary

Stumplifting technology requires tremendous amount of strength (several thousand Newton) depending on several factors like soil compactness, stump-diameter, tree species. According to our proposal the suitable strength and moment required to remove stumps can be significantly reduced if prior to application of any stumplifting technology compactness of the stump referring to its environment is to be reduced. One of the possible ways to implement this task is to vibrate the soil in order to loose soil – root correlation. The proper frequency of vibration seems to be the very case when the vibration frequency is equal to the stump – earth dominant own-frequency. Theoretically the equipment of vibration could be established on several techniques. But if practical approach occurs always the most applicable and the most efficient method should be selected. Since relatively enormous vibration performance and wide domain of frequency is required that is why to loose stump compactness application of technical elements of altering – current hydraulics is suitable. In the process of implementation of this equipment possible way of anchoring of phase-piston is to be guaranteed. We would be very pleased to launch very efficient, practical and applicable equipment, which can be easily attached to the power engine.

Introduction

The new challenges of forest economy, a better awareness policy as far as nature conservation and protection is concerned requires more efficient stumplifting technologies [5], [6]. Removing stumps may be carried out in different ways:

- traditional stumplifting technologies, mechanical technologies (winching system) or hydraulic push-or-tensile -fork machines,
- gripping stumplifting machines.

In Hungary in Alföld (Great Hungarian Plain) KISKUNSÁGI Erdészeti és Faipari Rt. (Kiskunság Limited Company of Forestry and Wood Industry) has introduced the application of CASE POCLAIN 1188 machines to remove stumps with gripping stumplifting technology. This equipment works as a hydraulic device. The test of ongoing operation on the premises of its application (Kiskunság, sandy, loose soil) proved it as to be suitable for the job. Up to the average stump diameter (40-cm cutting blade) it seemed to be ideal. In further cases when the diameter was above the average or the soil compactness was significant the procedure of stump-removal had to be consisted of several stages [3]. Stumplifting technology requires tremendous strength and moment (several thousand Newton) depending on soil compactness tree species and the diameter of the stump to be removed. Application of vibration to remove stumps the strength required can be reduced by 30-50 %. To achieve this significant result optimum level of frequency, and exact definition of the amplitude and bulk of the stump to be removed are required [7].

Application of vibration may result in the following beneficial outcomes:

- reduces the strength required to remove stumps that is why a performance of a smaller power engine is favourable,
- reduces the time of stumplifting procedure this way its application is cost effective,

- application of vibration will leave less soil on the stump removed, so in case of further utilisation of the stump,
- time and cost factors of cleaning can be reduced [1].

Establishment of vibration to loose stump

Typical properties of vibration are as follows:

- amplitude,
- frequency,
- performance of excitation (referring to the particular frequency and amplitude).

It results in that modification of the movement of vibration can only be carried out by modification of the properties outlined above. Meanwhile the process of planning and designing the new equipment is on these factors should be taken into good consideration. Theoretically this new equipment can be established on several techniques:

- mechanical,
- electric,
- hydraulic,
- hybrid (combination of the former ones).

But if practical approach occurs always the most applicable and the easiest to handle should be selected. Since relatively enormous vibration performance and wide domain of frequency is required to loose stump application of elements of alternating – current hydraulics techniques is suitable as far as the establishment of a new equipment is concerned [4]. Movement of vibration is to be generated by bi-phase, linear, alternating – current hydraulic drive. See 1. Figure. Draft of hydraulic drive. The most significant elements of the 1. Figure are as follows:

VHG: hydro-generator, (altering liquid stream-flow, divided phase) amplitude and frequency of the stream-flow of the hydro-generator is infinitely adjustable, depending on angle of the ex-central disc and the revolution per minute.

VMH: hydro-motor (altering current, linear movement) amplitude and frequency of the steam-flow of the hydro-motor determines the stroke and the frequency of the movement of the piston.

B: safety valve. Maximum pressure can be adjusted.

SZ_r: leak-loss replacement pump.

T: overflow valve. Regulates the pressure of leak-loss supplier pump (SZ_r).

D₁, D₂: Hydraulic diodes.

Formation of the vibratory equipment

In the process of formation of the alternating – current hydraulic motor's pistons the following factors should be taken into good consideration:

- different stump diameters,
- anchoring phase-pistons,
- tilting facilities of the piston in line-shaft direction of the stump.

Pistons of the alternating – current hydraulic drive can be linked in different ways with the stumps to be vibrated but the requirements outlined above should be seriously taken into consideration [2]. Pistons of the altering – current hydraulic hydro-motor can be symmetrically situated -parallel connection – on the circumference of the stump (2. Figure). The pistons are to be turned to each other guarantees that strength factors to be generated will not only be applicable in horizontal direction. That way stump can be moved in different directions.

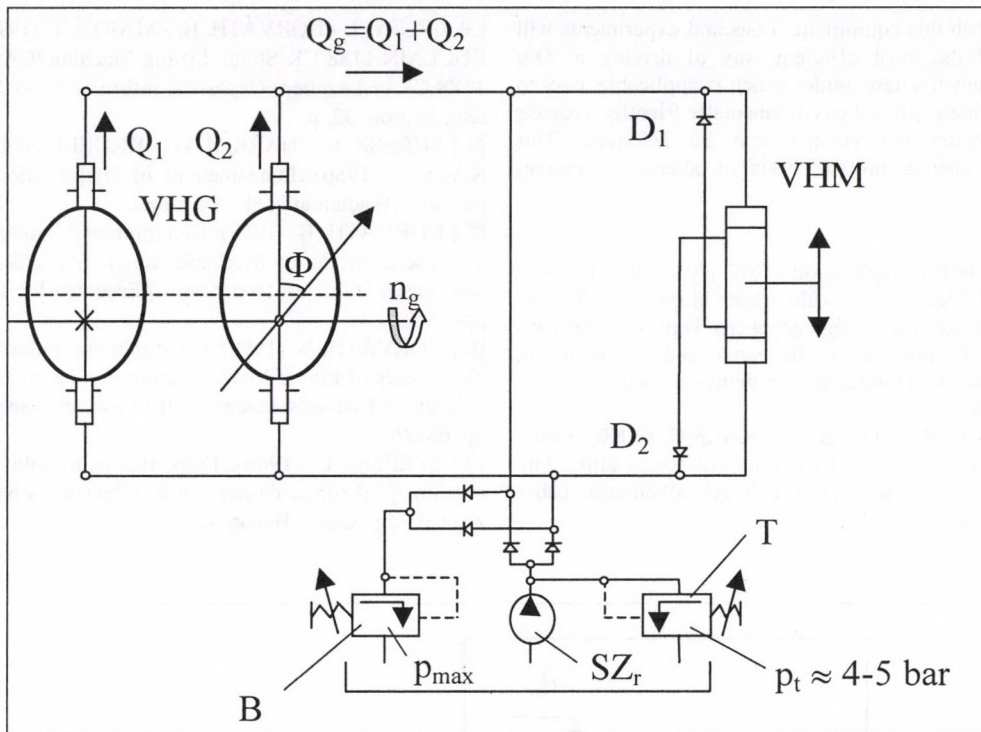

Figure 1 Draft of hydraulic drive

Drive design

Let's design significant sizes of bi-phase altering – current drive in the 2. Figure. As far as constructional reason is concerned let's choose $R/e < 10$ ratio, and $e = 10$ mm where

- R : radius of the disc of hydro-generator,
- e : eccentricity of the disc of hydro-generator.

Based on the technical parameters of the mobile power engine – to provide drive $P_{be} = 24$ kW input performance and $n_{be} = 1000$ 1/min input revolution per minute can be sustained. As a result the angular velocity of the hydro generator is as follows:

$$\omega_g = 2\pi n_{be} \approx 100 \text{ 1/s} \quad (1)$$

The performance of the equipment:

$$P = 2p_0 Q_{atl}$$

With the application of the following relationship it is calculable, where:

- p_0 : average phase-pressure,
- Q : average liquid stream-flow.

Interpretation of the average phase – pressure and interpretation of average liquid stream-flow is available in 3. Figure.

Moments of the hydro-generator can be described the following way:

$$M_g = \frac{P_{be}}{\omega_g} = \frac{24000 \text{ W}}{100 \text{ 1/s}} = 240 \text{ Nm} \quad (3)$$

Performance can be described

$$P = Fv = F \frac{Q_{atl}}{A_m} \quad (4)$$

in that way as well, where:

- F : the power generated by the piston of the hydro-motor,
- v : velocity(progress) of the piston of the hydro-motor,
- Q_{atl} : average liquid stream-flow of the hydro-motor,
- A_m : subsurface of the piston of the hydro-motor.

The average liquid stream-flow in case of bi-phase system based on the 3. Figure:

$$Q_{atl} = 0,6 A_g e \omega_g \quad (5)$$

Subsurface ratio of the pistons of the hydro-generator and the hydro-motor is calculated to be 1:2 and (5) substituted for (4) results in

$$F = \frac{P_{be} A_m}{0,6 e \omega_g A_g} = 80000 \text{ N} \quad (6)$$

Regardless of internal losses – based on 2. Figure and 3. Figure – we can describe the power of the bi-phase, linear hydro-motor:

$$F = F_1 + F_2 \\ F_1 + F_2 = p_1 A_m + p_2 A_m = A_m (p_1 + p_2) = A_m 2p_0 \quad (7)$$

Subsurface of the piston of the hydro-motor is $p_0 = 100$ bar average phase-pressure is supposed:

$$A_m = \frac{F}{2p_0} = 4 \cdot 10^{-3} \text{ m}^2 \quad (8)$$

It results in the diameter of the hydro-generator or the hydro-motor that way:

$$d_m \approx 70 \text{ mm}, \\ d_g \approx 50 \text{ mm}.$$

Stump machinery is required in the field works. Machinery used nowadays is only efficient in case of average stump diameter. And relatively adequate soil compactness. Machinery applied with altering – current hydraulics seems to be suitable to reduce the strength required to remove stumps. It results in application of a power engine with smaller performance. After clarification of all the theoretical and practical questions we would be very

pleased to establish this equipment. Tests and experiments will help us to find the most efficient way of driving it. Our objective is to launch a new model which is applicable, easy to handle, can be widely utilised environmentally friendly, protects the soil and better performance can be achieved. This equipment will operate on the basis of altering – current hydraulic drive.

References

[1.] CZUPY, I. (1999): Application of AC Hydraulics in Forest and Agricultural Machinery. (Váltóáramú hidraulika alkalmazása erdészeti és mezőgazdasági gépeken) Topics of Agricultural Technical Committee of Research and Development Conference of MTA (Hungarian Academy of Sciences). Nr. 23/1. pp. 331-334.
 [2.] CZUPY, I. - HORVÁTH, B. - LUKÁCS, J. (2000): Development of altering – current hydraulics for forest utilisation. (Váltóáramú hidraulikák fejlesztése erdészeti alkalmazás céljaira.) Gép 2000/8 pp. 15-17.

[3.] CZUPY, I. - HORVÁTH, B. - MAJOR, T. (1998): The CASE POCLAIN 1188 CK Stump Lifting Machine (CASE POCLAIN 1188 CK tuskózógép) Gépesítési információ, 10. Soproni Egyetem, Sopron. 32. p.
 [4.] FÜRÉSZ, F. - HARKAI, G. - KRÖELL DULAY, I. – LUKÁCS, J. (1986): Fundamentals of Hydrostatic Power Transmission. Akadémiai kiadó, Budapest.
 [5.] HORVÁTH, B. (1999): Condition and Future Development Tendencies of Forest Mechanisation I. (Az erdészeti gépesítés helyzete és fejlesztési tendenciái I.) Erdészeti Lapok, CXXXIV/2 pp. 38-39.
 [6.] HORVÁTH, B. (1999): Condition and Future Development Tendencies of Forest Mechanisation II. (Az erdészeti gépesítés helyzete és fejlesztési tendenciái II.) Erdészeti Lapok, CXXXIV/3 pp. 68-69.
 [7.] SZEPESI, L. (1966): Properties and application of forest machinery. (Erdőgazdasági gépek jellemzői és használata) Mezőgazdasági Kiadó, Budapest

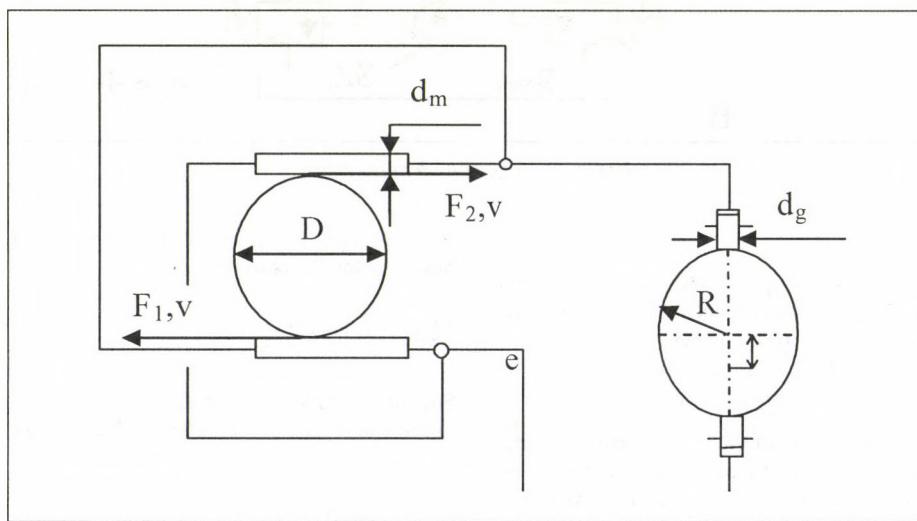

Figure 2 Bi-phase altering – current drive

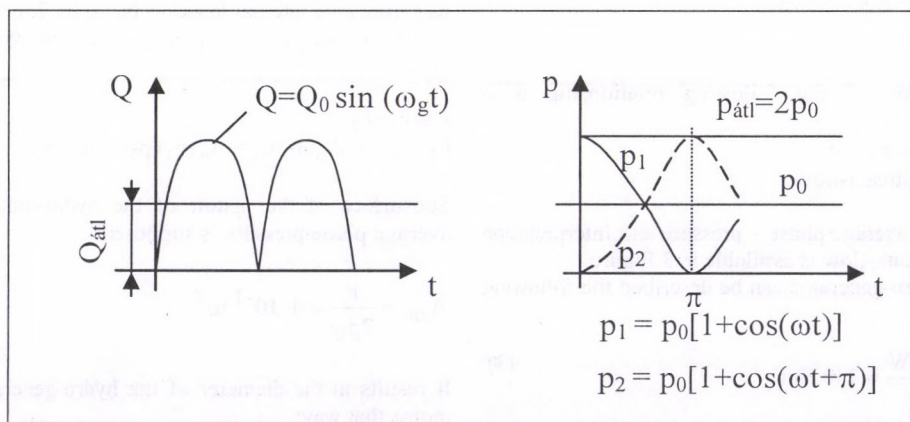

Figure 3 Interpretation of average liquid stream-flow and average phase-pressure

EXAMINATION OF FOREST STREAM SEDIMENT CHARACTERISTICS WITH PRINCIPAL COMPONENT ANALYSIS

Z. Gribovszki

University of West Hungary, Sopron

Abstract

In Hungary we have a fairly few information about erosion and sediment transport processes and relationship of these processes with environmental parameters. The following examination try to compensate this lack on the basis of sedimentation measuring in two neighbouring catchments (Farkas (Wolf) Valley and Vadkan (Boar) Valley) of Sopron Mountain.

Beside sediment quantity, sediment quality parameters are also available to trace of environmental changing caused natural and artificial impacts. Some kinds of disturbing effects are manifested better in changing of sediment quality parameters than changing of sediment discharge. The exploration of so many variables containing (sediment quantity and quality parameters) connection system is more expressive with complex statistical analysis. Under this work, relationships between sediment characteristics and environmental parameters have examined with principal component analysis.

1. Introduction

There is only a few data about soil loss measures under forest in Hungary. We have lack of data concerning relationship of erosion processes and the importance of factors effecting those processes, too. This article is trying to compensate this lack of information and supplement former researches (researches of

the Scientific Institute of Forestry in Kiszána, Hungary). The present target area is in two small watershed (Farkas Valley and Vadkan Valley) of the Sopron Mountain, Hungary.

First Hungarian soil loss measurements of forested, bare and gullying areas were made on the Erosion Research Station of Kiszána, in Mátra Mountain. István Héder, Gyula Bánky (Bánky, 1959) and Ferenc Újvári (Újvári, 1981) were researchers whose job was significant. In the Sopron Mountains researches of József Rác and Mihály Kucsara (Kucsara-Rác, 1991) in connection with sediment transport of forest streams can be mentioned.

2. Materials and methods

2.1. Characteristics of experimental watersheds

The examined small watersheds are situated in Soproni Mountain forest management scene, in the Brennberg Basin sub scene. The target area can be described as susceptible to erosion both because of its parent material, soils and sloping.

In the valleys during the examination period and just before the logging activity covered small areas. In Farkas Valley clear cuttings were far from the stream, in the Vadkan Valley covered twice as large areas and inside the buffer zone of the stream, so clear cuttings effected the stream's sediment transport (Figure 1.).

2.2. Measuring environmental parameters

Measurements of environmental parameters in connection with sediment movement were done in the experimental watershed. Precipitation and temperature data were originated from the

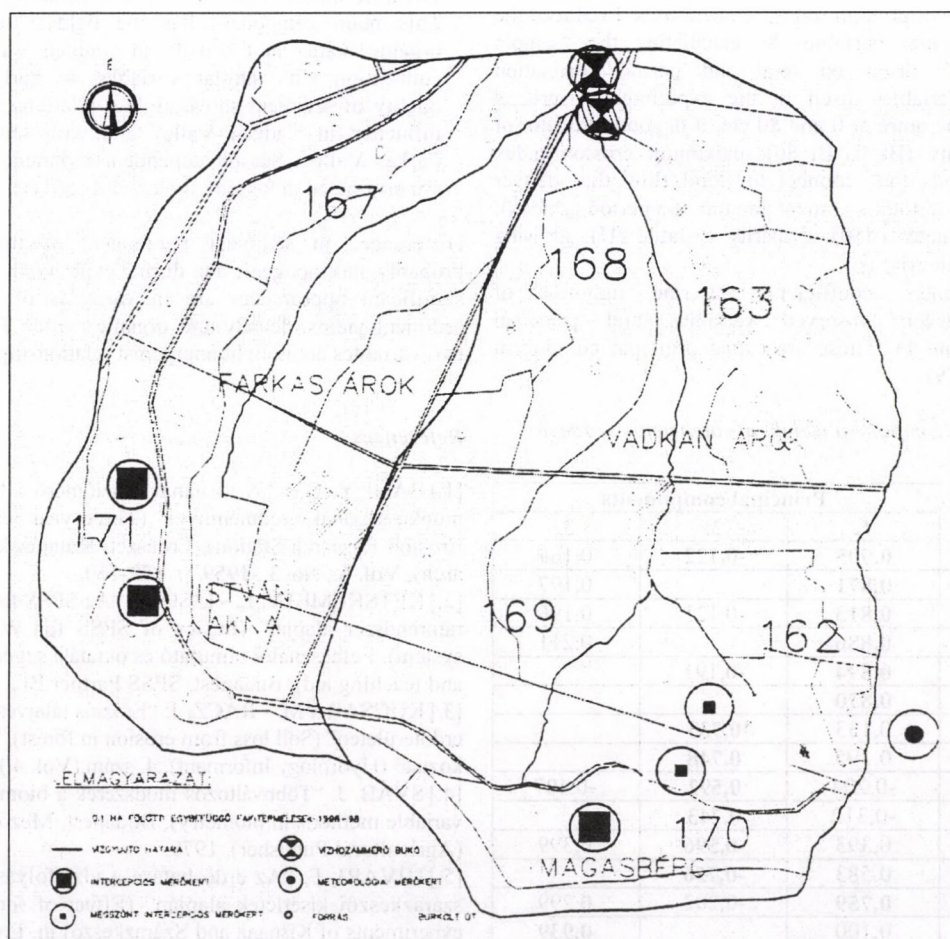

Figure 1 Experimentalcatchments

meteorology station of Hidegvölgy and from the automatic climate stations of interception gardens. Water yield data were provided from automatic water level sensors at the outlet profile of the watershed and from manual measurements.

2.3. Measuring rolled sediment

Sediment measurements were connected to water yield measurements with scaling the gathered sediment in the alleviator box. From sediment I measured mean particle diameter, disparity, density and organic matter since these parameters describes disturbance better than sediment yields. Experiments were done through the whole year, weekly or according to precipitation.

3. Results

Statistical analysis is able to describe the complex relationship system of the multiple variable database and to make it more expressive. I performed analysis of the complex relationship system variables and made groups of them with correlating the variables with principal component analysis. This way it is recognizable which groups are related, how many groups they form, what are the trends and how tight are the relationships (Sváb, 1979).

3.1. Relationship system of variables (principal component analysis)

a. Steps of analysis

First I analyzed all available environmental variable that potentially influence results like amount of precipitation, maximum amount of precipitation during sampling period, similar parameters of erosion index, temperatures. I reduced the number of redundant variables by calculating the "sample suitability value" based on total and partial correlation variables. The variables used in the experiments were as follows: soil temperature at 0 and 80 cm, it is good indicator of seasonal variability (Bt_0, Bt_80); maximum erosion index (Rd) inside periods that connect to flood flow that deliver maximum sediment; total sediment amount of a period (ghmax); mean particle diameter (d50); disparity variable (U); glowing loss (sze. a.); dry density (ρ).

Principal component coefficients describe tightness of relationship between observed variables and principal components (Table 1). These are called principal component weight (Sváb, 1979).

Table 1 Principal component weight of catchments sediment characteristics

| Variables | Principal components | | |
|-----------|----------------------|--------|--------|
| | 1. | 2. | 3. |
| VÁgh | 0,905 | -0,122 | 0,164 |
| FÁgh | 0,871 | | 0,197 |
| VÁghmax | 0,813 | -0,121 | 0,196 |
| FÁghmax | 0,886 | | 0,211 |
| VÁd50 | 0,894 | -0,191 | |
| FÁd50 | 0,870 | | |
| VÁU | 0,133 | 0,733 | |
| FÁU | 0,195 | 0,748 | |
| VÁsze.a. | -0,204 | 0,592 | -0,407 |
| FÁsze.a. | -0,312 | 0,743 | |
| VÁ ρ | 0,393 | -0,596 | 0,399 |
| FÁ ρ | 0,583 | -0,756 | |
| Rd | 0,759 | -0,202 | 0,299 |
| Bt 0 | 0,100 | | 0,939 |
| Bt 80 | 0,203 | | 0,918 |

b. Variables by valleys

The suitability of watershed variables for factor analysis is medium. Based on cumulative own values of main components the first 3 components own values are above one and reflect 74,4 % of total variance of variables.

- The first main component contains the main component of sediment that in tight relation with sediment yield and precipitation size. In this component the sediment yield and particle size have more weight in Vadkan Valley, daily maximum sediment yields shows higher values with Farkas Valley. This result shows that Vadkan Valley has bigger sediment yield and transport coarser sediment but valleys change characteristics at sediment move with very big flood waves. Quality characteristics like density, organic matter and disparity coefficient, in this order, in gradually decreasing degree are all in connection with the first main component but in case of Farkas Valley the relationship is always tighter. In Vadkan Valley this phenomena means lack of connection between quality and quantity sediment parameters and presumes presence of some background variable. This background variable is presumably originated in greater scale disturbance.
- In the second main component organic matter, disparity coefficient and density have big main component weight so it gathers sediment quality parameters in one group. Factor variables reflecting sediment quality has tighter relationship with second main component in Farkas Valley. So relationship among these quality components is univocal and clearer in Farkas Valley. The biggest difference between the valleys factor weight is in case of density and organic matter variables so these indicate quality differences of valleys.
- The third main component contains variables of temperatures. This main component has the tightest relationship with organic matter and density in Vadkan Valley but has no connection with similar variables in Farkas Valley. The quality of sediment shows tighter relationship with seasonal influence in Vadkan Valley and with sediment yields in Farkas Valley. Season dependent sediment quality changes are originated in logging time and its effects.

Differences in sediment parameters of these valleys are probably anthropogenic and during experiment periods the most significant appearances are in variables of maximum daily sediment yields, density and organic matter. However the last two variables are in tight antagonist relationship.

References

- [1.] BÁNKY, GY. "A kishánai eróziómérő állomás három évi munkásságának eredményei" (Three year results of Kishána Erosion Research Station), Erdészeti Kutatások (Forestry Research), Vol. 6., No. 3., 1959, p. 139-160.
- [2.] KETSKEMÉTY, L. - IZSÓ, L. "Az SPSS for Windows programrendszer alapjai" (Basics of SPSS for Windows program system). Felhasználói útmutató és oktatási segédlet (Users guide and teaching aid), Budapest, SPSS Partner Bt., 1996.
- [3.] KUCSARA M. - RÁCZ, J. "Eróziós talajvesztés vizsgálata erdőterületen" (Soil loss from erosion in forest), Hidrológiai Tájékoztató (Hydrology Informant), 4. szám (Vol. 4.), 1991, p. 22-24.
- [4.] SVÁB, J. "Többváltozós módszerek a biometriában" (Multivariable methods in biometry), Budapest, Mezőgazdasági Kiadó (Agricultural Publisher), 1979.
- [5.] ÚJVÁRI, F. "Az erdő hatása a vízlefolyásra a kishánai és szárazkeszői kísérletek alapján" (Effect of forest on runoff in experiments of Kishána and Szárazkesző) in: Erdő és Víz (Forest and water), Veszprém, VEAB kiadvány, 1981, p. 47-62.

FOREST ROAD PLANNING WITH THE SOFTWARE ERDÜTTERV

J. Péterfalvi - G. Markó
University of West Hungary, Sopron

Summary

It is impossible nowadays to make a forest road plan without aid of computer program. The main problem is not to find adequate hardware possibilities but to find the most suitable computer program that takes demands of forest road planning into consideration. The Department of Forest Opening Up and Forest Hydrology in West-Hungarian University has continually developed forest road planning programs from the 1980-s. Programs of early period had aided the planning process very much but handling them was difficult. The hot result of development is the 'Erdűtterr' computer aided designer program. This is a user-friendly program with graphical user face.

1. Introduction

During planning of the forest roads we aim to disturb the natural condition by creating roads in the slightest degree while we also try to provide the most favourable solution in technical and economic aspects. In the mountains and rolling country this can only be executed if we prepare, evaluate and compare more plan-variations during the planning period. Using conventional planning methods this required extra effort and time, therefore it is rarely applied in the practice. Development of the solutions in sufficient and comparable level during acceptable time required computer programs and up-to-date geodesic equipment. One of the facilities is the application of the planning system described in this article, including a self developed graphical planning software for road planning and AutoCAD, which is a general engineering planning software for graphical supplement and drawing. The developed application can accept format of data measured by the generally used measuring stations and digital level providing correct and fast data flow. In addition to this the appropriate documented self-prepared program can optionally be modified and developed.

2 The applied planning method

2.1 Primary data

Before the planning of the real centre line, the cross-section sample has to be designed and in the case of mountains and rolling country area the looking for the zero line on the map is also necessary.

2.2 Field measuring

Next step is to find the zero line designed on the map on the field and definition or measurement of a polyline that follows the zero line. The zero line will be measured according to this polygon, thereafter determination of the main and part point of the axle in the designed plot.

The attribute points of the field are detected for creation of digital interface model of the path of planned road simultaneously with plotting of the zero line. Increasing the number of the landmarks the accuracy of the interface model can be improved.

The measurement on the field and afterwards the laying out are executed practically by electronic measurement station. (The Department currently uses a Sokkia PowerSET measuring station)

2.3 Evaluation of the measured data

We evaluate the data recognised by the measuring station with a suitable computer program, as AutoGEO or Geoprofi. After the evaluation the X,Y,Z co-ordinates of the points of polygon, zero line and determined landmarks are available. These data can be used by the Erdűtterr and the points can be loaded on the graphical interface.

When we use the field-model we have to generate interface model applying the detected landmarks. The AutoGeo software is used for this step. The designed triangle-net (triangulare irregular network) can be inserted directly by the Erdűtterr.

2.4 Preliminary plans

The aim of the preliminary plan period is to design the optimal axis of the field plot. The digital interface model can help us in

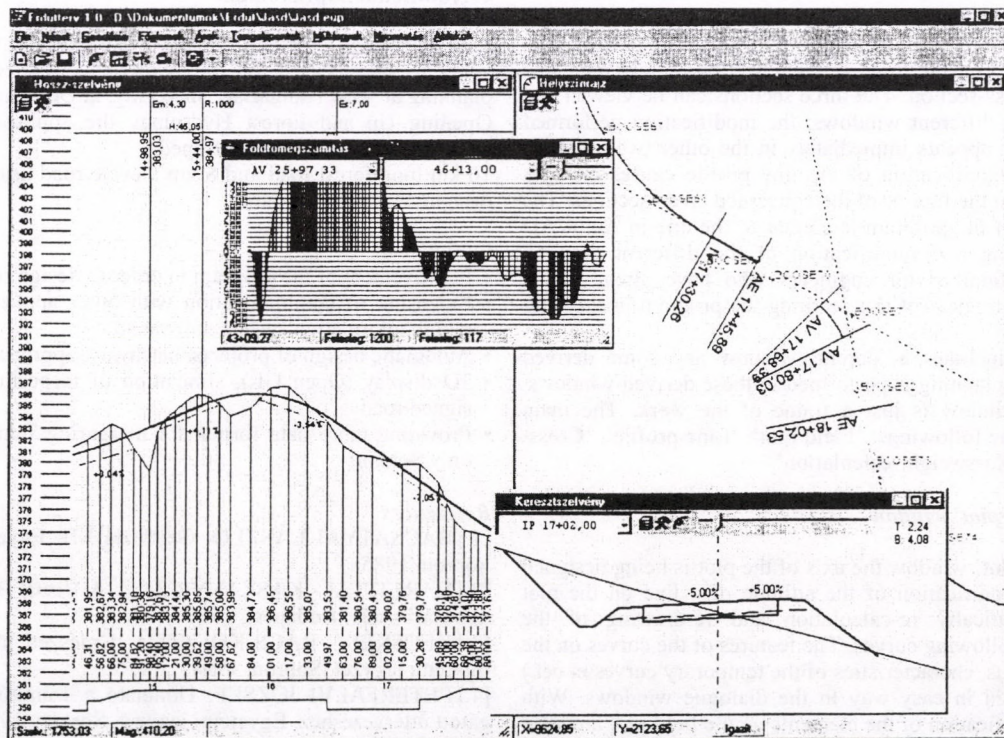

Figure 1 The graphical planning surface

objective comparison of the different variations of the plot since using this model we can design in a very short time the field line of the line profile of the actual variation. After loading of the path-line of

the preliminary line profile, the software can design preliminary cross-section also. Using these data the massweight-calculation can be executed. It can be decided that which part of the axis in the plot should be modified based on running of the field-line of line profiles, the slope of the field-line in the cross sections or massweight-calculation. After performing the required modification the longitudinal and cross-sections can be regenerated. This process can be repeated in several times till we get the optimal variation of the plot.

2.5 The layout of the axis in the plot, plotting

The software can provide the data required for layout of the final axis in the plot in printed form or in digitally, which is suitable for using by the measuring station. After the field layout of the axis it is necessary to determine the height of the axis points and to supplement the interface model in order to represent the relief in the most appropriate way.

2.6 Final planning

At final planning the axis of the plot is not modified, the field-line of the line profile is performed from the measured height of the axis points while the field-line of the cross section is generated from the enlarged or adjusted interface model. After the layout of the path, the calculation of the widening and camber in addition to design of the longitudinal draining, the final cross-sections can be drawn and the accurate massweight-calculation can be performed.

2.7 Additional tasks

After the export in '.dxf' format of the drawn part in final axis plan, the plan can be viewed with AutoCAD, we can supplement the plan (hatchway, approach, legend et cet.) and it can be plotted.

3. Presentation of the program

The Erdútterv 1.0 is a 32 bite software for Windows 95/98/NT operation system in order to plan forest roads The design of the road path based on the three original sections –field plot, line profile and cross-section. The three sections can be viewed and edited in three different windows; the modification performed in one window appears immediately in the other two sections. For example, modification of the line profile causes changes automatically in the figures of the concerned cross-sections. The self interface of the program is similar to the one in AutoCAD therefore editing and modification of the different drawing elements are familiar for engineers who have already used AutoCAD. As a result of this learning the program is easy and fast.

The program includes a 'parent' window and some derived windows. The planning is performed in these derived windows, the 'parent' window is just a frame of the work. The main windows are the followings: 'Field plot', 'Line profile', 'Cross-section' and 'Massweight-calculation'.

3.1 The 'Field-plot' window

In the 'Field-plot' window the axis of the plot is being designed graphically. Modification of the attitude of a line on the plot causes automatically re-calculation and re-drawing of the previous and following curves. The features of the curves on the field plot (radius, characteristics of the temporary curves et cet.) can be modified in easy way in the dialogue windows. With graphical modification of the elements on the field plot the most

coherent axis to the zero line (or to other control points) can be design simply.

Everything, what appears on the graphical interface, is situated on a sheet. The associative – in a certain aspect -drawing elements are loaded to one sheet. Modification of the characteristics of the sheets (colour, line-type et cet.), turn on and out, preparation of new sheet, delete of a sheet can be performed in 'Sheet' window.

3.2 The 'Line profile' window

In the 'Line profile' window, the altitude lay of line in the path and longitudinal drainage can be designed. The field-line of the line profile can be performed in two way: using the previously generated interface model or providing of the height of the measured points along the layout axis. The axis of the planned road is performed by equal sloping lines and connecting rounding curves. Fixing of layout of the equal sloping lines is based on section and height value of its one point and gradient of the line, while for design of the rounding curves we have to provide the radius.

The connecting drawing elements appear in different sheets in the same window.

3.3 The 'Cross-section' window

In the 'Cross-section' window we can view the cross-section figure of the main and detail points of the profiled axis. It is possible to check visually the designed longitudinal drainage in the line profile (adjusted wash-bottom lines) and perform of enlargement and camber. The automatically calculated charge and cut area is shown in the right upper corner of the window.

3.4 The 'Massweight-calculation' window

In the 'Massweight-calculation' the mass deficiency and excess value between two optionally chosen profiles is shown, which data are described graphically and in line-profile. Due to this parts are suitable for perform of mass adjusting can be found and we can choose the parts of the line profile, where modification is required.

4. Additional improvement

The recent form of the Erdútterv software is not the final version, since based on the experience of education and planning at West Hungarian University, at Department of Forest Opening Up and Forest Hydrology the application is being continuously tested and developed.

16 km long forest road and 8 km bicycle road has been already designed by this program.

Future plans:

- Improvement of the program in order to design roadway
- Extension of communication with other applications (geographic information system softwares)
- Automatic design of projects, hatchway, approaches.
- 3D display (Open GL), simulation of inspection of the designed road
- Providing more data format for measuring stations (recently only Sokkia)

References

- [1.] BÁC SATYAI LÁSZLÓ: Geodézia I-II. Egyetemi jegyzet. Sopron, 1985
- [2.] HARGITTAI - KASZANYICZKY: A Visual Basic 4.0 programozási nyelv. Budapest, 1997.
- [3.] KECSKÉS - RÁCS-KOSZTKA: Erdészeti útéptéstan I/A Egyetemi jegyzet. Sopron, 1991.
- [4.] PÉTERFALVI JÓZSEF: Útmutató a számítógéppel támogatott úttervezéshez. Egyetemi jegyzet. Sopron, 1996.

PLANNING OF OPENING UP NETWORK WITH DIGITERRA MAP GEOINFORMATIK SOFTWARE

M. Kosztka - G. Markó - J. Péterfalvi
University West Hungary, Sopron

Summary

Forest opening up networks, which is serviced Semi-natural multi-functional forestry, have to plan like a land opening up system because of several opening up demand are at the same time on the examined territory. During planning of the land opening up networks we try to gather all network system influencing demands and impacts and we try to plan network variations which exhausting these demands. The instantaneous best solution among variations can be chosen only throughout wide-ranging analysis. This means, that during planning and decision phases we need handle lot of geographic data, in which GIS programs help us. We have tried to elaborate planning of Börzsöny by aid of DIGITERRA MAP GIS software of DIGITERRA Bt. We established on the basis of this work, that elaborated network planning system by us and DIGITERRA MAP GIS software are suitable for planning of land opening up networks.

1. Introduction

The activity of forestry has significantly been reevaluated recently. The forest is expected by the society to be protective and fulfil public demands. These expectations often make a burden on production. Another demand is maintaining nature-friendly forestry that makes only small and frequent changes in order to handle forestry. The result of increasing demands towards services of forests and the limiting conditions controlled by nature-friendly forestry is that there is some activity carried out all over the total area of forests all year round. The opening up network should be created to cover the total area and work as an area opening up network.

Besides all the above mentioned facts the ownership has changed as well. The arable land including major part of forests became the property of different owners that creates new harmonizing tasks at the time of planning line-establishments.

When planning open-up road-systems serving the nature-friendly, multi-purpose, multi-owner forestry (TTT) the goal is to meet all the demands. Since this is usually impossible, creating the opening up network should be done in several steps, then the comparing and analyzing data necessary to select the appropriate version to be used must be completed.

Following decision making realization of network takes years or decades. Basic goals and interests may change during this time that can modify the opening up version accepted earlier. The plans must be modified relatively to these changes. Plan of the opening up network cannot be considered completed at a given time but it must be revised all the time in compliance with the changes of what base is a dynamic planning system.

The management system is the base of the dynamic planning system. The management system controls the goals, the planning works out alternative solutions, the analyzes needed for decision making, the process of realization through an information system, and it checks if our goals are approaching via feedback.

Effectively operating information system can only be created in these days if it is based on computer system based geo-information system. Goal, demands and limitations of nature-friendly, multi-purpose, multi-owner forestry are presented as geographical information on the forest area that must be taken into consideration during planning. As a consequence of this geo-information program is needed when planning opening up network. One of the main considerations in choosing the applied software was to work as a forestry road database besides

meeting requirements necessary to planning the network. According to our analysis the DIGITERRA MAP geo-information program package, used also by ÁESZ, seemed the most appropriate for this purpose.

2. Applied software

Planning of opening up network of Börzsöny was the first project where the opening up network planning system was used and tested its serviceability. The DigiTerra Map program developed by DigiTerra Engineering Company was used for planning. The DigiTerra Map is a high-level integrated geo-information software that enables creating nation-size geographical database, either they are vectorial, raster map data, terrain models or map-related descriptive data (attributes). The software includes all the tools needed for completing tasks mentioned above: integrated thematic mapping, map creating, analyzing tools, digital image processing and land profile modeling, relative database controlling and report making tools. The geographical information data model consists of a graphical (geometric) and a text (descriptive) segment. There can be a relational data-connection made in between these two segments. The process to create this connection is making a link. The appropriate data of the two segments will be connected by a geo-code. These geo-codes are simple serial numbers and relates to the serial number of the record belongs to a geometric element.

3. Planning forest opening up networks in the Börzsöny

3.1. Data collection and map creating

The 1:10000 scale forestry map was the base for the two dimensional information of area included in planning and its surroundings as analog data model. The descriptive data of the operational planned areas was provided by the forest-stock database. The demands of the area were collected and classified by SWOT analysis included all parties involved.

The IPOLY ERDŐ Rt. provided us with the operational map sections and related database. Using the DigiTerra Map program we could attach new data charts to the primary data charts. These new charts contained the demands towards forest opening up and data necessary to analysis.

For the planning Börzsöny traffic network (public roads, operational roads, railroads) was also required to be stored in a separated map-format database. This was created by over-digitizing the lines belonging to the recognizable public and operational roads of the digital map, and by scanning important parts of paper-printed maps and digitalizing them.

3.2. Representing demands on maps

The vector-, raster- and surface elements describing geographical objects are represented by the program on map views. These map views are built up of themes necessary to planning and they will appear according to our needs after data screening and thematic classification. There can be several map views opened and organized on the screen at the same time to be able compare and analyze them. This way the limitations and demands towards forest opening up can be represented on series of thematic maps that are made of geographical objects of the digital map and descriptive data important from the demands viewpoint.

We created and printed 16 different thematic maps while planning the opening up network of Börzsöny. Based on them it got proved that they were only pictures to represent the objects but not maps to work with. The planning had to be carried out on the screen based on the database. The traditional representation of these maps had to be finished because we there could have been created a great number of thematic maps due to

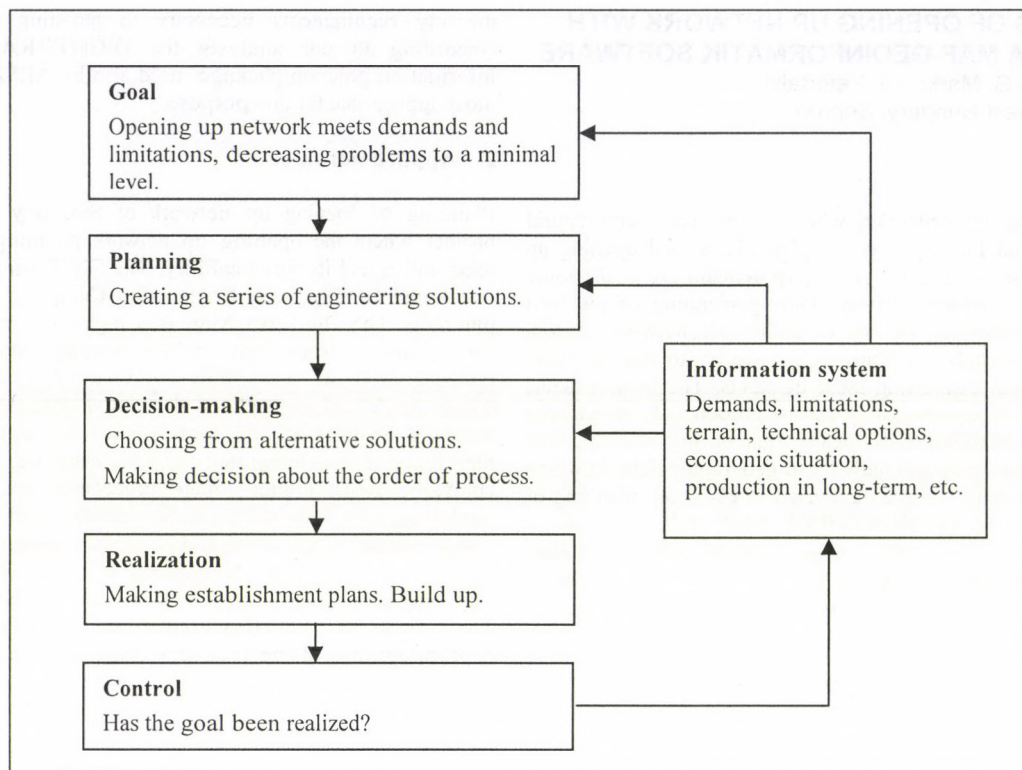

Figure 1 Management system of forest opening up networks

the tempting options provided by the database and printing these thematic maps would have been really costly on one hand, while on the other hand it would have made further work inflexible.

The geo-information database created for the forest opening up planning provides further analyzing options, and in these cases analysis should be carried out on the map view created based on the map view appearing on the screen according the actual problem.

Our thematic maps were created from the data necessary to forest opening up and based on the database we had and modified. The number of thematic maps could have been extended if we had had the choice to create more connected database.

3.3. Planning networks versions

When studying the demands a limiting condition leading from the point of view of planning the network was drawn out and it was the demand of environment protection. The forest segments were classified into three groups based on the data provided by environment protection: protected, highly protected and parts where building roads is forbidden.

The planning of lanes building up the network was influenced by not only the demands and limitations of environment protection but by viewpoints of forestry. Planning the network these appear in the opening up conception that provides the accessibility of forest parts considered by owners and also the production technological ways of arable land opening up (subtle opening up). Since forestry does not have a completed conception for this purpose yet, we considered the given lane-imaginings of forestry, the crosswise slope of the area, and terrain during planning.

Other demands such as protective, public and tourist demands could not be recognised and built in the database because of the reserved attitude of environment protection and also due to the not really determined representation of inhabitants.

We tried to avoid the negative cardinal points and the highly protected forest parts when finding the elements of the network on the map but it was not always realizable. Avoiding making new lanes through these areas was a general rule, and this was realizable in almost every case.

3.4. Finding the neutral line

Knowing the demands and limitations and based on certain terrain information the opening up network was planned up to the neutral line.

In order to be able to find shorter or longer neutral lines following the terrain profile we needed a program module developed by the software developer to our request following some discussions. The three dimensional terrain profile, that contained the lines, was an irregular triangle-shape net (TIN) based surface model. Each way was usually created by planning even-gradient slope road sections following each other on by one. The development of the program cannot be considered completed but using them we can eliminate using paper-printed maps when finding neutral lines. During planning we have found approximately 700 kilometers of neutral lines using this method.

3.5. Comparing analysis of versions

During creation of opening up network we have used two different approaches and so we have worked out two different versions.

We had to carry out an analysis based on objective basis so as to be able to compare the completed versions and for this reason measurable data are practical to be used for evaluation. These are provided by the analytical part of the program.

The complex opening up index, the direct opening up index and the opened up area-ratio index were created for the comparison of the two versions. Representation of the length and crosses of existing and planned roads opening up the forest across the

areas noted as "road building is forbidden" was also very significant.

Also the size of forest crossed by several roads and opened up more times was represented.

An interesting statistics could be created knowing the favorable approaching center points. This data depends on the advancing tool and technology that was not available for us. It must be noted that information not included in the database cannot be maintained by computer science either.

Based on the above detailed we can say that the planning method built on the applied geo-information software is an effective method that enables us to follow the constantly changing conditions and starting data, and the necessary modifications can be carried out and represented following an examination of our goals. This way the flexibility becomes obvious that has an important role in fast and careful decision making.

4. Results, recommendations

During planning the opening up network of Börzsöny we concluded that the DIGITERRA MAP geo-information program

package is far suitable for dynamic planning opening up networks and creating a forest road-database to be realized later on. It is important to note that the geographical information programs based planning system requires a totally new approach. In case of changing conditions data can be easily and quickly replaced, the three dimensional data can be represented according to the new conditions, they can be analyzed in numerous versions, the thematic maps can be created and represented on the screen within minutes. They can be saved, stored and forwarded. All these advantages can only be utilized if the information stored in the database up daily updated. Questions cannot be answered even by the information system of what answer-related data are not stored in the database.

References

[1.] KOSZTKA, M: - KUCSARA, M: - PÉTERFALVI, J.- GRIBÓVSZKI, Z. - MARKÓ G. - KALICZ P. (2000): A Börzsöny komplex, közjóléti feltárása. Kutatás-fejlesztési jelentés. Kézirat. Sopron, 2000.

[2.] KOSZTKA, M (1993): Erdőfeltárás a társadalmi változások és a többcélú erdőgazdálkodás feltételei között. Kutatási jelentés. Sopron.

TRIBOTESTING OF ENGINEERING POLYMERS

L. Zsidai - G. Kalácska, Szent István University, Gödöllő
 P. De Baets, University of Gent, Belgium
 M. Kozma
 Budapest University of Technology and Economics

Summary

The engineering applications of plastics are strongly connected to the different tribological systems, where the machine parts are subjected to friction and wear processes. The design for lifetime of metals in tribological systems has not solved yet, even less known for engineering plastics. The test evaluation and concluding process are rather difficult taking the specific behaviour and features of the polymers into consideration. Due to this point we have been carrying out a wide-ranged tribo-testing with large-scale and small-scale plastic specimens. Based on the obtained results seeking the correlation between the two main systems we try to conclude more general principles. This paper gives a short view about the small-scale experiments. We have done measurements with plastics like POM-H; PETP/PTFE; POLYAMIDES. This was a linear friction-sliding measurement of cylindrical specimens against a metal plate. Measurement was made at 100N and 200N load and in two surfaces categories.

1. Introduction

This presentation is based on a part of an international tribology research program seeking the correlation between large-scale and small-scale tribo-testing of engineering plastics.

The frictional and wear processes are the basic cause of the failure of machines. A solution can be the use of self lubricating plastics. One-one test is not enough for determining the tribological behaviour in a certain system. Taking the specific features of plastics into account, we can observe perfectly the tribological behaviour of plastics with small-scale and large-scale testing. We have done measurements with plastics like POM-H; PETP/PTFE; POLYAMIDES types.[2];[5]

The method for testing is a linear sliding friction measurement without lubricants. The sliding friction is created by a polymer cylinder which is moved against a steel plate in a counterformal contact. The polymer cylinder is fixed to the moving fixture, and it cannot turn away during the test. Measurements are made at 2hours/100N load (category I.) and 1hour/200N load (category II.) and in two surfaces categories. (fig.1)

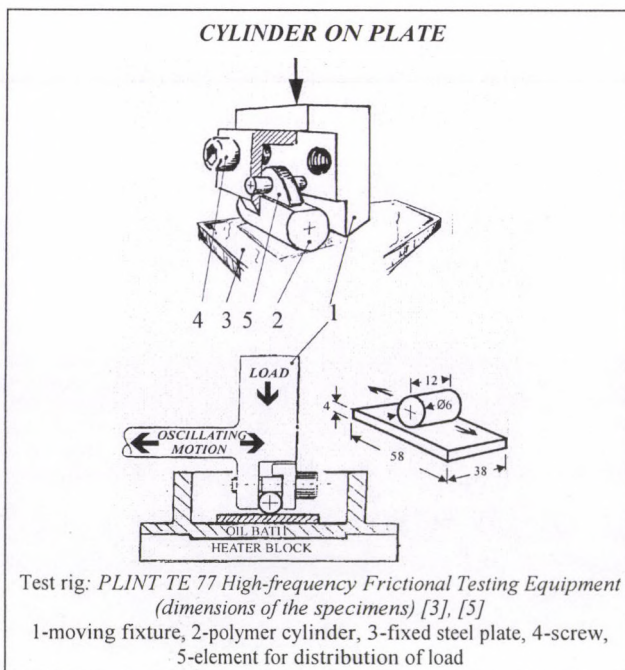

Figure 1 The equipment and the method [4]

Aims: To determine the optimal operational conditions, to define the basic failure process of engineering plastics during sliding frictional conditions, taking the severe requirements into account related to the safety against overload, too.

2. The test materials, properties

The standpoint of choosing materials depended on the bearing manufacturers, the demand of users and wide range of applications. Among the selected materials two are filled composites having different features in sliding and wear properties. [3];[6]

POLYAMIDES PA 6 G (reference); PA 6 G+oil; PA 6 G / Mg (catalyzed)

The cast polyamides are used for tests among the wide ranged polyamide types. The main properties of cast polyamide: high strength, stiffness, thermo- and wear resistance, excellent creep resistance, hardness, good machinability, water absorption

POLYOXYMETHYLENE HOMOPOLYMER POM-H

The properties related to PA 6 G: higher crystallisation ability than copolymer, high strength, stiffness, hardness, excellent creep resistance, good sliding properties and wear resistance, very good dimension stability

POLYETHYLENE TEREPHTHALATE PETP+PTFE (composite)

Properties of PETP+PTFE: solid lubricant spreading homogeneously (PTFE composite), improved wear resistance, lower friction coefficient comparing to virgin PETP; POM-H and PA, higher load concerning contact pressure and velocity.

3. Parameters of tests

| PARAMETERS | CAT. I. | CAT. II. |
|--------------------------------|------------------|----------|
| Frequency (f) (velocity) | 30Hz (0,27m/s) | |
| Running time (t) | 2 hours | 1 hour |
| Load (L) | 100N | 200N |
| Stroke (s) | 4,62mm | |
| Surface of metal specimen (Ra) | 0,02-0,1/0,1-0,2 | |
| Humidity (H) | 50% | |
| Ambient temperature (T) | 30°C | |

| MEASURED PARAMETERS |
|--------------------------------|
| Static friction coefficient |
| Dynamic friction coefficient |
| Wear (mm) |
| Ambient temperature (constant) |
| Relative humidity (constant) |

(Ra 0.02-0.1 is called smooth and Ra 0.15-0.3 is called rough surface)

4. Compare of the results

According to the results of our investigations the followings can be established. We can see each type of materials of both investigations on column diagrams in both categories. The values of the friction coefficients are shown in diagrams in order. These values are averaged from more measurements.(fig.2), (fig.5).

Test carried out 2 hours/100N

POM-H

Favourable, nearly similar frictional results ($\mu_{dyn.mean} \approx 0,25-0,3$) were measured on both surface roughness. The initial peak was followed by a reduction and stabilization stage in the friction results. The smoother surface the less wear.

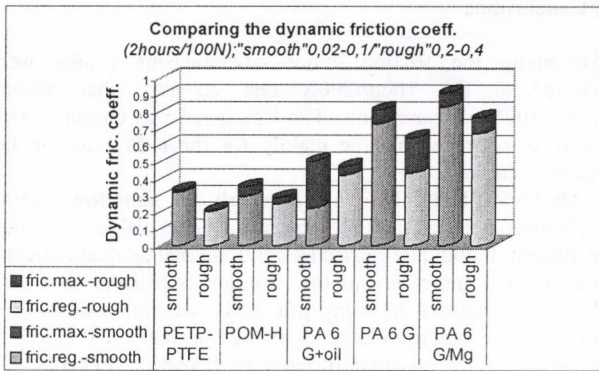

Figure 2 Comparing the dynamic friction coefficient among different materials, classifying according to surface roughness (2hours/100N)

PETP+PTFE

Advantageous effect of the internal lubricant was detected during sliding. Generally small wear ($w=0,048\text{mm}$) was measured varying on the different surfaces. The curve of friction is rather levelled. (fig.3)

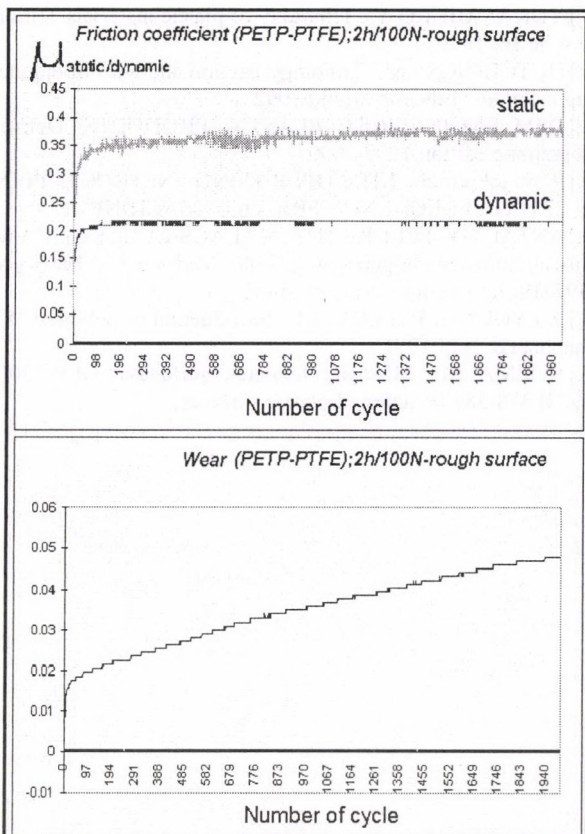

Figure 3 Friction coefficient and wear of PETP-PTFE, 2hours; Load=100N; rough surface

POLYAMIDES

The polyamides have higher friction coefficient than the former polymers.

- PA 6 G+oil shows better sliding properties than virgin PA 6 G and PA 6 G/Mg (lubricant effect).
- PA 6 G/Mg shows about 20-25% higher sliding resistance than the natural PA 6 G. The wear is less than other polyamides have. This can be the result of the different catalytic process of the production. We can conclude from the wear curve a high surface toughness against wear. (fig.4)

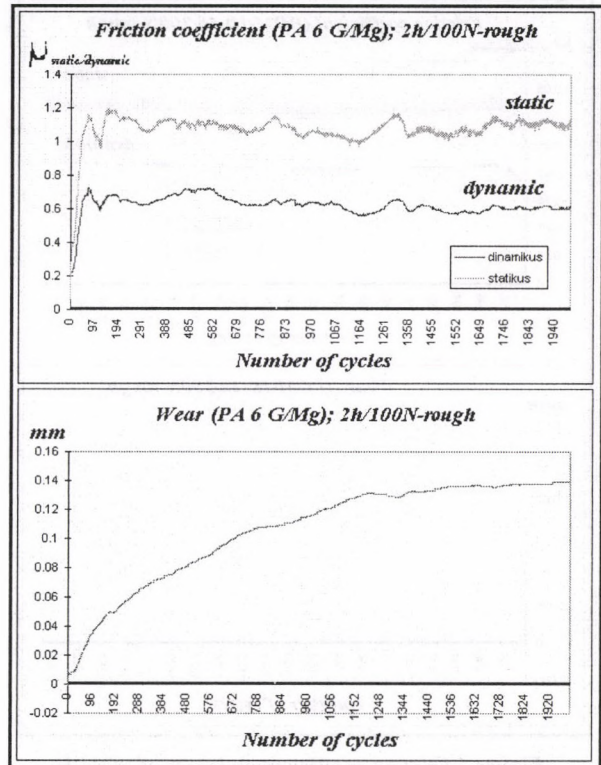

Figure 4 Friction coefficient and wear of PA 6 G/Mg 2hours; Load=100N; rough surface

Tests carried out 1hours/200N

POM-H

Lower friction coefficient at rough surface and increasing friction coefficient at smooth surface was found. The wear was almost similar at both surface roughness. (fig.6)

PETP+PTFE

The internal lubrication showed positive effect on the value of friction coefficient. The wear was small and almost similar at both cases($0,0235\text{mm} \leftrightarrow 0,0241\text{mm}$).

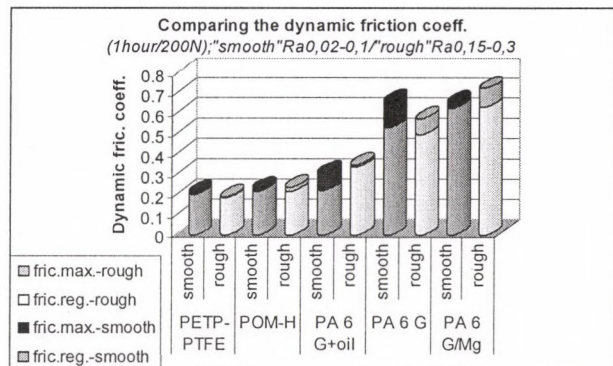

Figure 5 Comparing the dynamic friction coefficient among different materials, classifying according to surface roughness 1hour/200N)

POLYAMIDES

- In case of PA 6 G+oil the difference of the friction coefficient was lower comparing to the other polyamides. This phenomena signs the important role of the load and surface deformation of plastics. The internal lubricant could not act as effectively as under lower load (2 hours/100N category).
- The load is higher the friction is lower of PA 6 G materials. The difference in friction depends on the filling material and production technology.

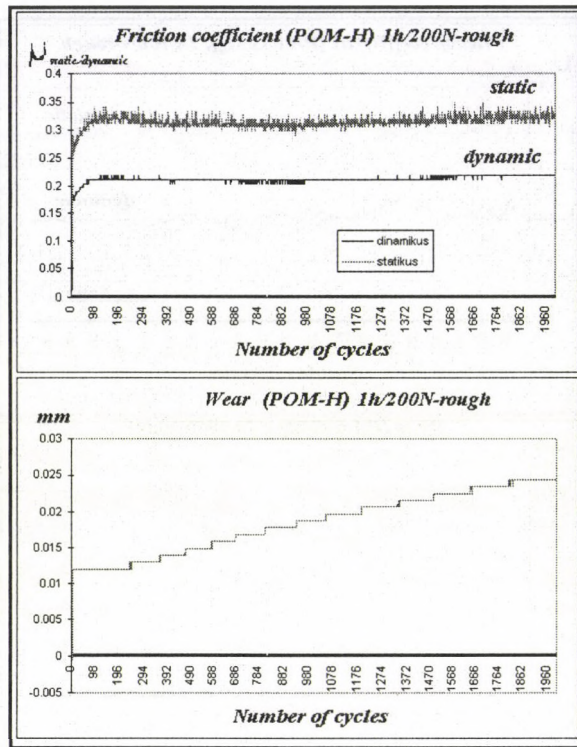

Figure 6 Friction coefficient and wear of POM-H
1 hour; Load=200N; rough surface

- The wear velocity of PA 6 G on rough surface decreases suddenly after a certain period of time getting a transient point. The same tendency can be seen on the curve of friction coefficient, too. These phenomenon due probably to a polymer transfer process, which was observed on the metal specimen.
- The friction results are almost similar at PA 6 G/Mg ($\mu_{\text{dyn.mean}} \approx 0,58-0,62$) at both roughness, but the wear is quite different ($0,1961\text{mm} \leftrightarrow 0,6324\text{mm}$).

5. Conclusions

Concerning the friction, more advantageous results were detected at the 1hour/200N test category than during 2hours/100N measurements. The test speed was constant. This statement seems to be true mainly for the tests made on the smoother surface.

POM-H and PETP/PTFE showed nearly the same low friction coefficient, but PETP/PTFE gave a bit better value of friction coefficient. It could be caused by solid internal lubricant effect. POM-H has more favourable friction coefficient than the polyamides have. (In many practical cases the widely used POM-C shows more unfavourable friction than PA 6 G/Mg. It seems there are essential differences between POM-H and POM-C in the friction properties.)

6. Acknowledgements

The authors wish to acknowledge the Office OTKA for supporting this work by the research project of OTKA T 032590. This publication and research is supported by the Flamish- Hungarian bilateral scientific and technological cooperation (OMFB T&T B-9/98), too.

References

- [1.] YUKASABURO Y.: Tribology of plastic materials Tribology serie 16, 1990
- [2.] HUTCHINGS I.M.: Tribology friction and wear of engineering materials. Edward Arnold 1992
- [3.] DSM ENGINEERING PLASTIC PRODUCTS. Delivery programme edition 1999-2000
- [4.] Plint & Partners LTD: OPERATING INSTRUCT. PLINT TE 77 HIGH FREQUENCY FRICTION MACHINE
- [5.] ANTAL GY. FLEDRICH G., KALÁCSKA G., KOZMA M.: Műszaki műanyagok gépészeti alapjai. Minerva-Sop Bt. Sopron 1997 (Basics of engineering plastics)
- [6.] R.J.YOUNG; P.A.LOVELL: Introduction to polymers; ITP Chapman & Hall 1991
- [7.] KOZMA M.: Műanyag felületek súrlódása. GÉP. 30/10 (1978) 378-381 (Friction of plastic surfaces)

OPTICAL CHARACTERISTICS OF TRANSPARENT INSULATION MATERIALS

M. Szűcs - I. Farkas
Szent István University, Gödöllő

Summary

In this paper the optical characteristics of transparent insulation (TI) materials are studied. During the analysis various geometric structures and materials were taken into account. The light transmission measurements were carried out by the use of Ulbricht-ball and with the help of a laboratory measuring unit. The light transmission factors for different TI materials and structures were determined at a different incident angle of light radiation. Sensitivity of light transmission on the thickness was also determined.

1. Transparent insulation materials

Transparent insulation (TI) materials are used to reduce heat losses of buildings. The advantage of TI over traditional insulation lies in their high transmission of incident light and near infrared radiation which leaves the possibility open for exploiting the solar energy. Its excellent light directing/diffusing properties make it ideal for buildings in daylight systems. TI reflects a large proportion of the strong light produced when the sun is directly overhead and evenly distributed glare-free natural light.

Various transparent and translucent materials can be used for transparent insulation, such as glass, acrylic glass (PMMA), polycarbonate (PC) and quartz foam in varying thickness and structures. To protect them from the effects of weather and mechanical stresses these layers are sandwiched between two panes of glass.

Transparent insulation materials can be basically classified into four geometric structure types (Fig. 1) [1]:

- a. structures parallel to the exterior surface,
- b. structures perpendicular to the exterior surface,
- c. cavity structures,
- d. quasi-homogeneous structures.

2. Optical characteristics of TI materials

The group a) consist of several layers arranged behind one another parallel to the glass surfaces and enclosing separate air spaces. This arrangement entails higher reflection losses, an effect which can be partly reduced by the use of anti-reflection coatings. Examples are glassing systems comprising multiple panes of glass, such as double or triple glassing or plastic films. The group b) includes the structures arranged perpendicular to the exterior surface, such as louvers, honeycombs and capillaries, which divide the cavity into small air cells. This type has the advantage of lower optical losses, as the incoming beam is reflected several times from the parallel surfaces and transmitted in a forward direction. This opens up the possibility of increasing levels of natural daylighting at the back of deep rooms. A further advantage is that the convection currents are suppressed an effect resulting from the relationship between the diameter and the depth of the air spaces.

Honeycomb structures consist of transparent polycarbonate (PC) with ultraviolet-stabilising additives. They are extruded as continuous structures, and have very good optical property. Capillary structures are made up of many small plastic or glass tubes. The plastic tubes of acrylic (PMMA) or polycarbonate (PC) have a diameter of 1-4 mm is depending on whether light-scattering properties or higher radiation transmission are desired.

The group c) variety is the cavity type which combines parallel and vertical structures. These materials are used with bubble structures in the order of a few millimetres such as acrylic foam. Although these largely suppress heat losses through convection, the losses through reflection, as with the parallel structures and through heat conduction are a limiting factor.

The group d) consists in the quasi-homogeneous structures such as aerogels and xerogels which have microscopic cavity structures. A less expensive alternative is the manufacture of granular aerogel which consists of 1-6 mm diameter pellets loosely poured in the cavity between the panes. However, this granular form of aerogel has poorer optical and thermal properties.

3. Measured TI materials

In the recent study two different measurements were performed with different TI materials.

To carry on the first measurements with Ulbricht-ball the following TI material used:

The thickness of the polycarbonate honeycomb TI material is 62 mm for surface perpendicular structures and 50 mm for surface of 45 degree angle structures. The measure of the cavity is 3x3 mm (Manufacturer: Licht und Energie-Optimierungssysteme GmbH-L.E.S., Germany).

The thickness of the PMMA capillary TI material is 40 mm for surface perpendicular structures and 22 mm surface of 45 degree angle structures. The average diameter of the capillary is 3 mm (Manufacturer: OKALUX Kapillarglas GmbH, Germany).

The further covered transparent and translucent materials in glassed sandwich construction consist of 3,3 mm thick glass pane, 8 mm thick air cell polycarbonate and 16 mm thick acrylic (PMMA) panel.

The TI material of the second measurement (with developed laboratory measuring unit) were 1-10 cm thick honeycomb polycarbonate plates (AREL) and 5 cm thick diagonally glued, pleated cellulose acetate film (MONIFLEX).

4. Light transmission measuring units

Optical characteristics of several transparent insulation materials and a few glassed-sandwiched constructions were measured by the Ulbricht-ball. This measuring unit is situated in the research laboratory of Institut für Technik in Gartenbau, Hannover University.

The diameter of the Ulbricht-ball is 1 m, and it is from inside painted of white. The light intensity is measured by photoelectric cell (HAMAMATSU R136 type photomultiplier), which is situated on the upper edge of the ball. The photoelectric cell is connected with FERRAND type of supply and monitoring unit.

It is a horizontal axle movable reflector to produce direct solar radiation. The zenith distance is adjustable by 10 degrees. The 150 W halogen-reflector inside is black painted. The approximately parallel lighting is produced by built-in lens. The axle of reflector is situated over a turnbare table with 1,4 m in diameter. In the middle of the table it is a quadratic aperture. The light transmission of the samples are covered – in accordance with the material types – with a suitable narrow framing.

Diffuse light can be produced in a half-ball with 4 m diameter. Its centre is in the middle of the table. The six pair strip lightings and reflectors are on the inside surface providing diffuse radiation without shadow. All surfaces in the room except the ball inside, are black painted.

Before the measurements the apparatus must be calibrated: by closed stop number of 0 % and by opened stop number of 100 %. In such a way the percent of light transmission can be easily obtained.

With the help of a developed laboratory measuring unit it is possible to measure and compare directly the different thermal and optical characteristics of transparent insulation materials. The unit was developed at the Department of Physics, Szent Istvan University Gödöllő. The artificial lighting is provided by a radiating source of light, fixed to a holder of the measuring unit in an adjustable height position. The temperature of the insulated surface is measured by a digital temperature sensor located on the middle of the examined area. In order to measure the lighting conditions a lux-measuring unit was used.

5. Comparison the optical characteristics of transparent insulation materials

The result of measuring of light transmission factor of different TI materials with a surface perpendicular structures by various incident angle of light can be seen on the Fig. 2. In the figure the light transmission characteristic of TI honeycomb and capillary structures are shown. The curve is symmetrical from both radiation directions. Near to the extreme values (± 80 and ± 10 degrees) there are convex sides of the curve because of special optical effects (reflection).

In Fig.3 the light transmissivity on the surface of 45 degrees angle of arrival is shown. The light transmissivity is the highest when the radiation is parallel with the TI structure. Near to the extreme angle values there are convex sides of the curve because of the reflection effects.

In the Table I the transmissivity data for different glassed sandwich constructions can be seen. In the first construction two glass plates and in the second and third ones two polycarbonate plates were used for covering. The light transmissions of single layers and the complete constructions were measured by direct and diffuse light radiation as well. The

highest light transmission was measured for the first construction [2].

With the help of the laboratory unit a comparison was carried out between the light transmissivity of 1-10 cm thick polycarbonate TI material, which was about 0,88. The light transmission of 5 cm thick honeycomb polycarbonate plate was double of the 5 cm thick diagonally glued, pleated cellulose acetate film.

6. Conclusion

Several structures of TI materials have very different light transmissivity at the same thickness. Generally saying, the higher is the thickness of the TI structure the less is the light transmission, but the rate of the difference is lower in a smaller angle of radiation.

The light transmission of the measured 1-10 cm thick polycarbonate TI capillary structure does not decrease significantly by expanded thickness when the direction of lighting parallel with the structure.

References

- [1.]COMPAGNO, A.: Intelligent Glass Facades, Birkhauser, Basel, Boston, Berlin, 1995.
- [2.]SZÚCS, M., KOHLMEIER, D. (1998) Transzparens hőszigetelő anyagok fényáteresztésének vizsgálata, MTA-AMB, Kutatási és Fejlesztési Tanácskozás, Gödöllő, 2001. január 23-24. p.36. (Measuring of transmissivity of transparent insulation materials, Conference on research and Development, January 23-24, 2001, Gödöllő, p.36, In Hungarian)

Aknowledgements

This study was carried out with the support of FKFP 459/2000 project.

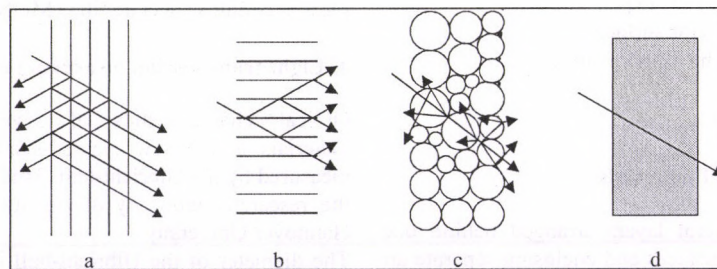

Figure 1 Various geometric structures of transparent insulation materials [1]
 a) structures parallel to the exterior surface, b) structures perpendicular to the exterior surface,
 c) cavity structures, d) quasi-homogeneous structures

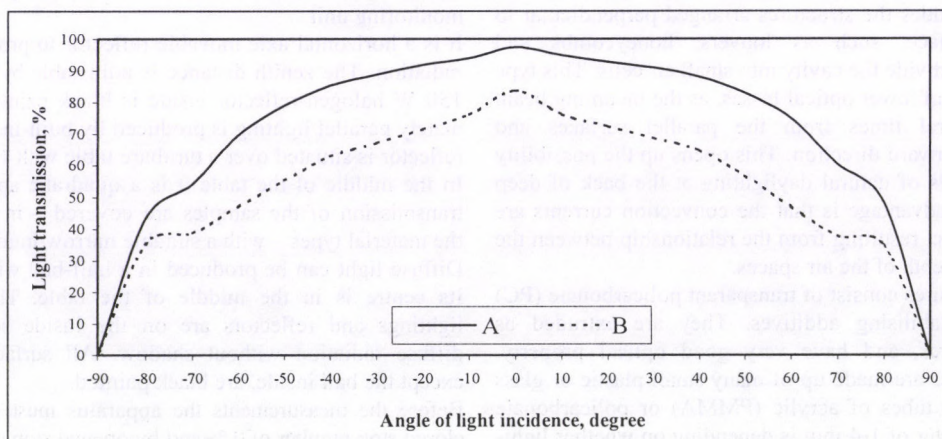

Figure 2 Light transmission factors for surface perpendicular structures
 (A: 40 mm thick capillary TI (polymetilmetakrilat, PMMA), B: 62 mm thick honeycomb TI material (Polycarbonat, PC)) [2]

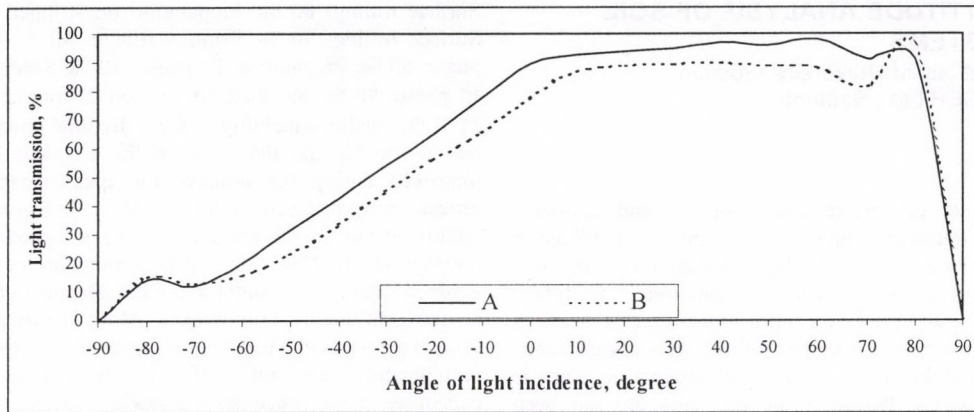

Figure 3 Light transmission factors for surface of 45° angle of light
 (A: 22 mm thick capillary TI (polymetilmetakrilat, PMMA), B: 50 mm thick honeycomb TI material (Polycarbonat, PC))

Table 1 Light transmission factors of several TI materials and glassed sandwich-construction

| Construction | Light transmissivity, % (direct/diffuse) | | | | | | |
|----------------------------|--|-----------|-----------|-----------|-----------|-----------|-----------|
| | K1 | K2 | K1+K2 | TH1 | TH2 | K1+TH1+K2 | K1+TH2+K2 |
| K1a TH1, TH2 K2a | 91/83,6 | 90,8/82,7 | 83/73,7 | 98,3/87,6 | 83,7/67,3 | 81,6/65,6 | 69,1/53 |
| K1b TH1, TH2 K2b | 80,5/65,7 | 79,8/68 | 64,8/50,2 | | | 62,2/46,3 | 51,9/38,9 |
| K1c TH1, TH2 K2c | 85,6/77,4 | 84,7/74 | 74,8/62,9 | | | 71,2/57,5 | 54,4/48,6 |

Notes:

K1, K2: transparent insulated construction (model)
 K1a, K2a: plate glass (t=3.8 mm)
 K1b, K2b: polycarbonate (t=8 mm)
 K1c, K2c: Acryl SDP 16/32 (t=16 mm)

TH1: transparent insulation (KAPIPANE, t=40 mm)
 TH2: transparent insulation (L. E. S., t=62 mm)
 t - thickness

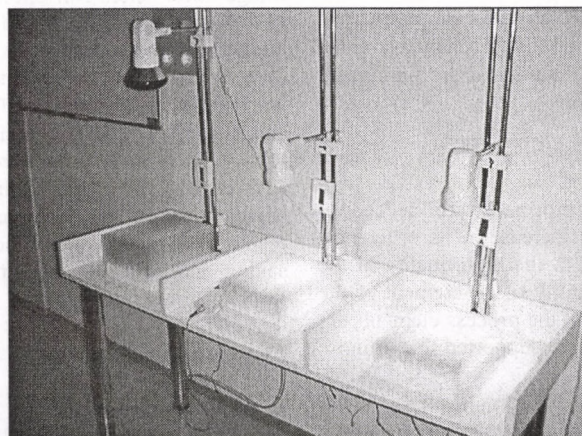

Picture 1 Laboratory unit for measuring the optical and thermal characteristic of TI materials

PROCESS-ATTITUDE ANALYSIS OF SOIL TILLAGE SYSTEMS

M. Birkás, Szent István University, Gödöllő
L. Csik, MEZŐGÉP Ltd., Szolnok

Abstract

The process a set of interrelated resources and regulated activities, which transforms inputs into outputs. Soil tillage in the quality assurance respect can be considered as a process, and is to be evaluated by process-orientation. Soil tillage systems can also be accepted by a linear process series. A multi-traffic soil tillage system can consist of nine process elements. If the quality capability of the individual process elements is below 100%, and the faults of the elements are not been improved during the process, the quality capability of the process series has also got a lower level. According to the national tillage experience were determine the main phases of the tillage system, which affect on the quality of the next phases and on the other ones as well. It was stated, that combination of the process elements and development of those quality capabilities are to improve the capability of the output (that is soil condition suitability to sow). Combination of the elements results in a decrease of the tillage faults (e.g. a multi-traffic system vs. a till-plant system). In this study the advantages of the process attitude adoption are also summarised. This paper present results of research programs supported by OTKA 34.274 and INCO COPERNICUS CA ERB IC15.

Introduction

In the quality assurance relation a process is a regulated action for realization of the specifications. Any tillage operation (e.g. loosening, ploughing) can be seen as a process, as well as the tillage system as a process series [1,2]. Specifications are regarded to the tillage operation quality or to the soil condition improvement or conservation. A process can be seen quality capable if its results fulfil the specifications with a great probability. In soil tillage relation a process or a process series can be evaluated a quality capable if it creates harmony between crop production' demand and environment conservation.

Material and method

During the former research, a requiring system of the quality assurance in soil tillage, was planned [2, see Fig.1]. The conception that is any tillage operation (e.g. loosening, ploughing) can be considered as a process, was strengthened. There were stated, that the output character of a process affects as an input character to the following process, however it can be appeared as an output character on other process or processes. A close connection was determined between a multi-phases soil tillage linear process series and the conventional multi-traffic tillage system[3]. There were examined that the decrease in the process number has an impact on the quality of the final result (such as a soil condition ready to sowing).

Results

Measuring and qualifying of the processes are needed to determine of the process output and increase in its efficiency. There are two standpoints regarding to the high quality of the final results. Partly the quality capability of all element of the process is to improve partly number of the process elements are to decrease. The following examples are supported this promise [Figs 1,2].

The quality capability of the elements in a multi-phases linear process characterising the conventional tillage system according to national practice are as follows: 1. Stubble stripping: 90 %; 2.

Surface rolling: 80 %; Preparation on stripped stubble:95 %; Surface rolling: 90 %; Primary tillage: 90 %; Preparation 1st phase: 80 %; Preparation 2nd phase: 90 %; Seedbed preparation 1st phase: 80 %, Seedbed preparation 2nd phase: 95 % [Figure 2]. If the quality capability of the individual process elements is below 100 %, and the faults of the elements have not been improved during the process, the quality capability of the process series has also got a lower level. In a given example the quality capability in the end of the 9th phase (its product) corresponds to 30% that is specifications are not fulfilled. The seedbed quality is unsuitable for the germination requirements resulting an uneven crop density. More energy and costs were used than were planned and in spite of this the agronomical requirements are not fulfilled. Determining the quality capability of the processes a checklist was used with a points method [3].

Improvement of the quality capability of some processes is needed for the sake of the decrease those unfavourable impacts on the following processes. In Hungary the conventional multi-traffic tillage systems are realized with a low quality capability level. That's why the improvement of the quality capability in certain processes is remarkable mainly under extreme climatic conditions. The soil moisture loss after a wrong-done stubble stripping is resulted clodding in the primary tillage. An unsuitable seedbed quality can be occurred in spite of the multi-traffic preparation. A wrong decision increasing the number of the process elements, since then the regulating, disturbing effects and fault possibilities will also be increased. There are six disturbing factors in multi-phase soil tillage linear process series [Table 1].

The effectiveness in soil tillage system can be improved by the process analysis. The crops are required a soil condition is suitable for germination, growth and rooting but those are not demanded the traffics in number or turning the soil down. That is the demand of the crops is independent of the number of tillage operations or of the tillage methods [Figure 3]. There are more possibilities in reduction of soil tillage systems. The direct drilling has the less traffic and other reduced systems show more favourable features than conventional ones. In the example of the Figure 3 the primary condition is the stubble, and the final is the planted soil. In this system all tillage operation is combined, including primary or secondary ones. The number of the tillage system (that is number of the process elements) is three and the number of the disturbing factors is one [Table 1]. The soil condition is favourable to sow can be realized by the combining of the process elements and by the decrease of the disturbing factors. The quality capability of the process elements on the basis of an example from the practice a are follows: Stubble stripping and rolling: 98 %; Primary tillage and preparation: 99 %; Seedbed preparation combined with sowing: 99 %; that is the quality capability of the simple soil tillage linear series corresponds to 96 %, which demonstrates a total fulfilment of the specifications. The improvement of the quality capability on process elements was realized by the use of up-to-date and combined tools. The advantages were proved not only in the agronomical features (less compaction, clodding and dusting) but, in the economical ones (less cost and energy loss). That is the soil structure conservation was simultaneously realized with the energy saving. A most important result, that a harmony can be developed and maintained between demand of the crop production and of the environment by the use of energy saving and soil conservation methods without increasing the farming risk in a long term.

Conclusions

1. Lack of the correction in faults occurring during the execution of process elements that the number and harm of the accumulated faults show an exponential increase at the output

point of process series [Figure 4]. The improvement of the quality capability of the process elements has a favourable effect on the final result (soil condition).

2. A reasonable reduction in the process elements results a decrease in the number of the disturbing factors (or possible faults). In this case less quality-risk factors are to considerate and its analysis require less time.

3. Less tillage procedures can be done in an optimal period with a better quality and with less cost. A further advantage that the possible faults of the process cause smaller harms, which can be improved more easily with less costs.

4. Reduction of the tillage processes by the use of the combined tools requires a higher expertness, and this equipment are usually expensive, however those dependability are greater than individual and simple ones.

References

[1] BIRKÁS M. - CSÍK L. 2000. Művelési hibák megelőzésének lehetőségei minőségbiztosítási módszerekkel. MTA-AMB XXIV. Kutatási és Fejlesztési Tanácskozás, Gödöllő, január 18-19. Kiadvány (szerk. Tóth L.-Benkóné Pongó D.) I. kötet 27-30.

[2] BIRKÁS M. - CSÍK L. 2001. Minőségbiztosítás a talajművelésben. In: Talajművelés a fenntartható gazdálkodásban (szerk. Birkás M.) Akaprint Kiadó, Budapest, 231-288.

[3] BIRKÁS M. - CSÍK L. 2001. Talajművelési rendszerek folyamat-szemléletű elemzése. MTA AMB XXV. Kutatási és Fejlesztési Tanácskozás, Gödöllő, 2001 január 23-24. Összefoglaló Kiadv (Szerk. Tóth L.-Benkóné Pongó D.), 27.

Table 1 Disturbing factors at a multi-phases and a simple soil tillage linear process series

| Serial nr. | Considerable disturbing factors at a multi-phases linear process series |
|---|---|
| 1. | Moisture loss deteriorating the soil workability between 1-5 phases |
| 2. | Additional considerable moisture loss between 2-5 phases |
| 3. | Strong clodding due to moisture loss between 1-6 phases |
| 4. | A slightly alleviation in clodding between 5-7 phases |
| 5. | A slightly alleviation in clodding between 5-8 phases |
| 6. | A recompacting possibility between 5-9 phases |
| Possible disturbing factor at a simple soil tillage linear series | |
| 1. | A possible moisture loss between 1-3 phases |

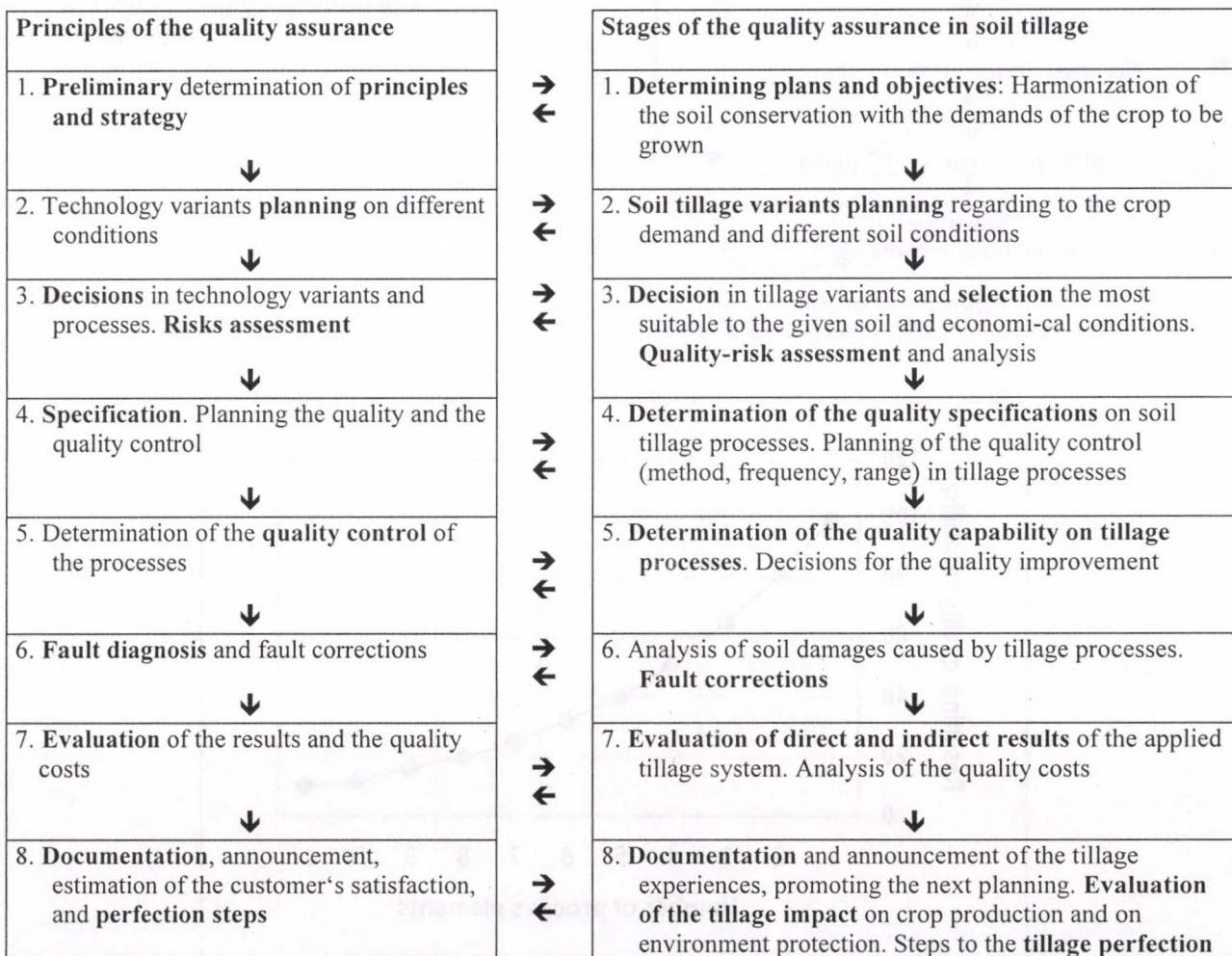

Figure 1 Scheme of the quality assurance improving soil tillage quality

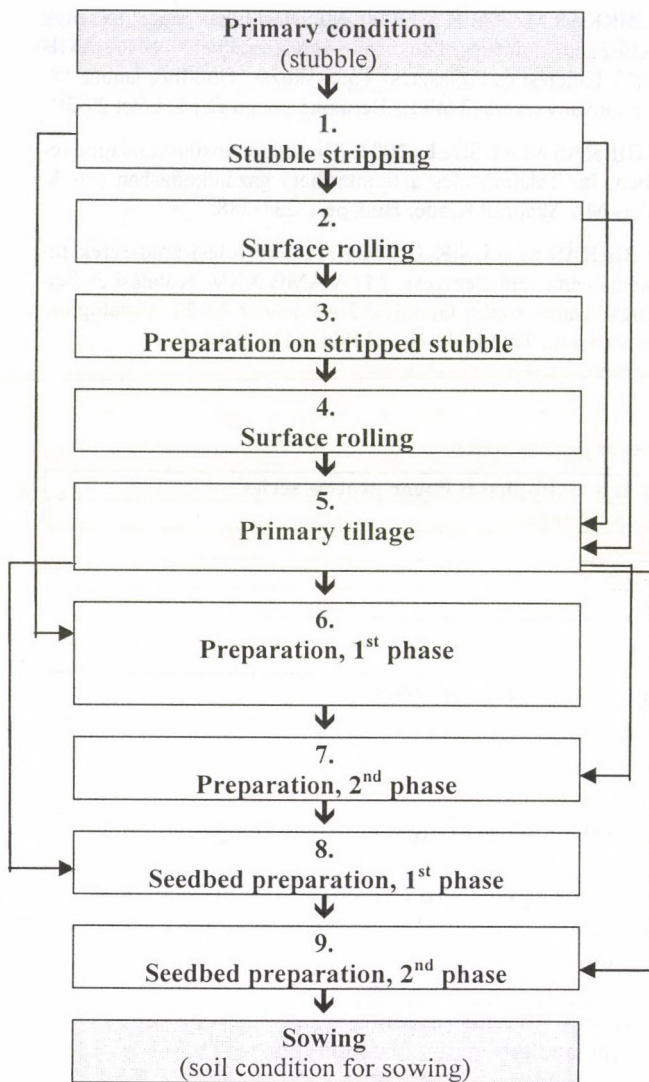

Figure 2 Scheme of the multi-phases soil tillage linear process series

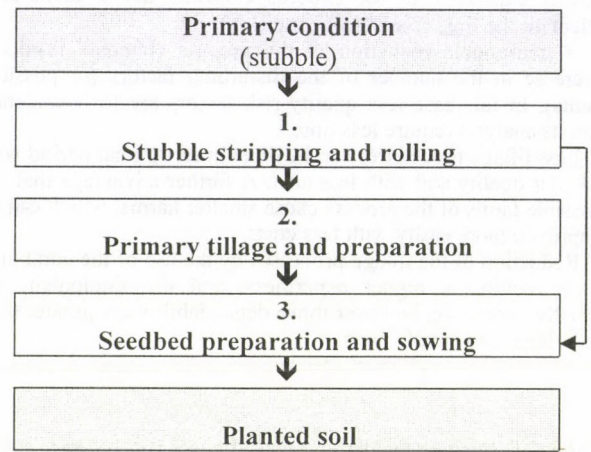

Figure 3 Scheme of the simple soil tillage linear series

→
Input/Output characteristics
→
Considerable regulating impact on
an other process
(or a disturbing factor)

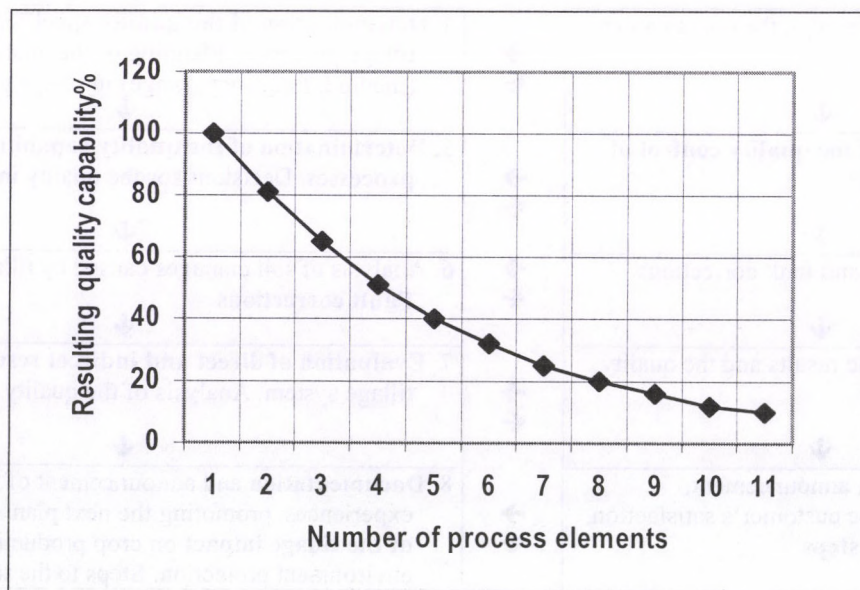

Figure 4 Resulting quality capability in the process series if the capability of the process elements has 90 % rate

MEASURING CUSTOMER SATISFACTION AS AN ELEMENT OF QUALITY EVALUATION

P. Vermes - S. Szűcs

Tessedik Sámuel College Mezőtúr, Faculty of Agriculture

Abstract

The satisfaction of customers is an important index number of the power of the organization. To get information related to customers' satisfaction is not easy. The problems are caused by a "slit" at the joining points of customers and organization that cause a loss and distortion of information. The poster paper shows the procedures that organizations apply in the area of collecting and processing customer information.

The relationship between customer satisfaction and quality management

In all instances, the stake of market competition is keeping customers and winning the trust of potential ones. These goals can be achieved only if manufacturing and/or service companies are able to explore and interpret the needs of customers, and satisfy them at the highest possible level with their product and joint supporting activities. In addition, companies have to provide an authentic certification of their ability to sustain and develop the quality customers experienced.

Quality assurance and quality management systems were created to assure customers that companies are able to fulfil their needs continuously and reliably, by meeting the requirements of uniform, international standards certified by an independent party.

Although the ultimate purpose of companies is to reach a high level of **customer satisfaction**, in the previous version of ISO 9001, compliance with a 20 element model was prescribed only. The current version issued in 2000 already prescribes that companies must meet their customers' demands, to reach their satisfaction. ISO 9004:2000 (basically the standard of TQM) takes one more step forward, writing about the satisfaction of all parties involved. **Figure 1.** shows the relationship between satisfaction and system elements.

All organizations that wish to create and certify a quality management system must be concerned with measuring and analyzing customer satisfaction right from the beginning, while those planning to reform their systems must deal with it from 2003 at latest.

Section 9.2.2.1. of ISO 9001:2000 says organizations must follow and observe information regarding customer satisfaction and dissatisfaction. They have to define methods and measures to obtain and analyze data and information.

Section 9.4 - Repair data analysis - prescribes that organizations have to analyze available data to obtain information on, for instance, customer satisfaction and/or dissatisfaction and compliance with customers needs.

Measuring and analyzing customer **satisfaction** is a **requirement of the system**. However, the method of collecting and analyzing information is not prescribed. Considering its content, prescriptions of the standard are explicit. All characteristics of products and services that are important from the point of view of customers have to be examined. These characteristics have to be identified already in the stage of planning so that the functions of products and their parameters could be determined.

It is inevitable to measure and evaluate customer satisfaction, to be able to assess the performance and effectiveness of the system.

Therefore, from the point of view of demands, the task is relatively clear. There are far more unsolved problems in the field of carrying these tasks out.

Regarding products, customers have various requirements, some of which can not be measured quantitatively. Depending on to what extent these requirements are met, the customer develops a feeling of satisfaction towards the product or service, which motivates his/her decisions fundamentally. The result of the decision can be purchasing products or services, or switching to the competitors.

Although customers examine products and services from many aspects, their decisions are based upon their overall impressions. Therefore, in measuring customer satisfaction, an overall index is also needed.

It is vitally important for organizations, to be able to identify the elements of customer satisfaction, and to be able to give feedback at appropriate levels of the organization, at the process or activity of production, or for the person producing the product. Only in this case is the company able to make decisions and changes that lead to an increase in customer satisfaction.

So at determining customer satisfaction levels, a **multi-factor evaluation method** or model is needed, in which all elements are found, and is able to produce generated indicators.

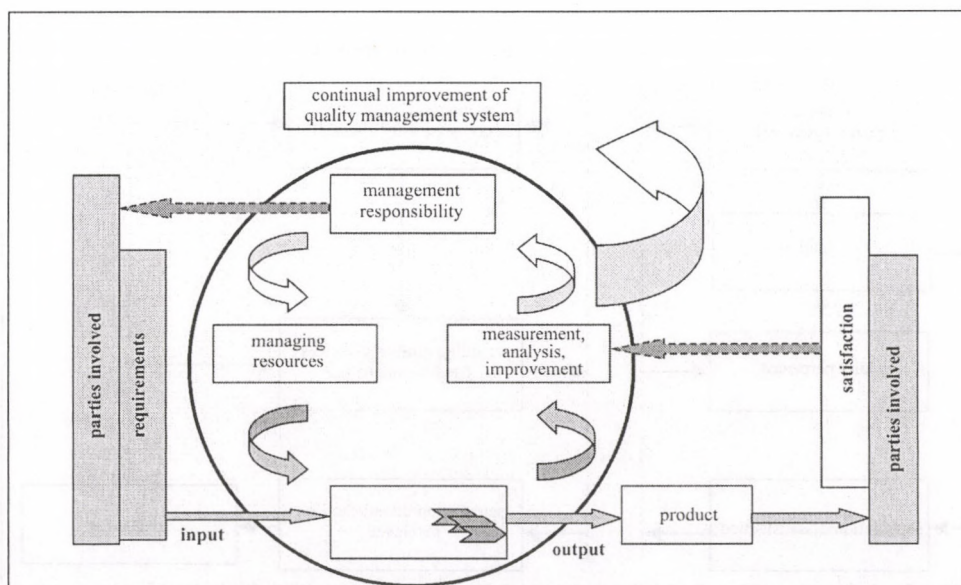

Figure 1 The flow model of quality control system

Collecting information from customers

It is not an easy task to obtain the information needed to analyze and evaluate customer satisfaction. In most cases, channels between customers and organizations are not able to transmit information without distortion or loss. One of the biggest problems in the process of information flow is how to bridge and decrease the "slit" between customers and organizations (Fig 2.).

Experience shows that the traditional methods of marketing or public opinion polls can only be used with changes.

Measuring customer satisfaction is not equal to a simple market research, it is building a long-term relationship with customers.

Customers have to be aware of the importance of their work, so that they do not take offence at our asking questions, try to give realistic and well-considered answers, and to give answers at all. They have to get feedback on how their opinions were used and what the results are. That is why at some companies, so called "secret customers" are employed, who have the task of doing regular, random shopping, e.g. at Burger King.[1]

In practice, there are various **methods** used which were created in public opinion polls:

- Individual interviews
- Focus groups interviews (group discussion)
- Telephone interviews
- Mail questionnaires

All the methods listed have advantages and disadvantages. Many times, the limiting factors are time and costs.

Another important question is **who to ask**. Since questions have to be related to some specific experience, only those can be asked who already had some kind of contact with our product, or a similar product of our competitors. Therefore, the two main groups we can ask are:

- Those currently using our product or service
- Users of competitive brands

As a third group, the so-called potential or prospective buyers can also be included, who have never bought the product or service, neither at our, nor at another company, but have a need for it. This group can not be defined in advance, but they can also be included in the survey to a certain extent.

If groups taking part in the survey are defined, we have to decide on the size of the **sample**. This decision is based on

financial and statistical questions. How much are we going to spend on the survey, and what level of confidence do we expect?

It is practical to work with **permanent groups**, because this way, the people interviewed can see our system as it develops, they form an opinion based on the same values, and they are easier to form a long-term relationship with. Homogeneous sample groups have to represent the whole set.

Motivating interviewees is also an important question. By motivating people, especially in the case of telephone surveys or mail questionnaires, the rate of responses and the energy invested in the answers can be increased significantly. Incentives often used are:

- Shopping discounts, sales allowances
- Presents
- Prize-draws [2]

A phone number that can be called free of charge can also be successful. The disadvantage of this method is that results are hard to convert into statistics: it is hard to identify the caller, the segment of buyers he/she belongs to.

Apart from this, this method can be very useful for organizations, since users of free numbers usually transmit their complaints and dissatisfaction. Putting an end to the causes of dissatisfaction is more important, than increasing the satisfaction level of customers already satisfied.

It is a general experience that:

- 100 new buyers bring 2 new ones
- all complaints reported have at least 20 not reported behind
- to get a new customer costs five times as much as keeping one [3]

The most important question is probably **what to ask**. There are no general rules to answer this question, but the possible themes are the following:

- functions of the product/service, the parameters and completeness of these functions
- professional support
- providing information
- the method and content of the contact with customers
- reliability, credibility
- disposability in time
- expenses
- style, appearance

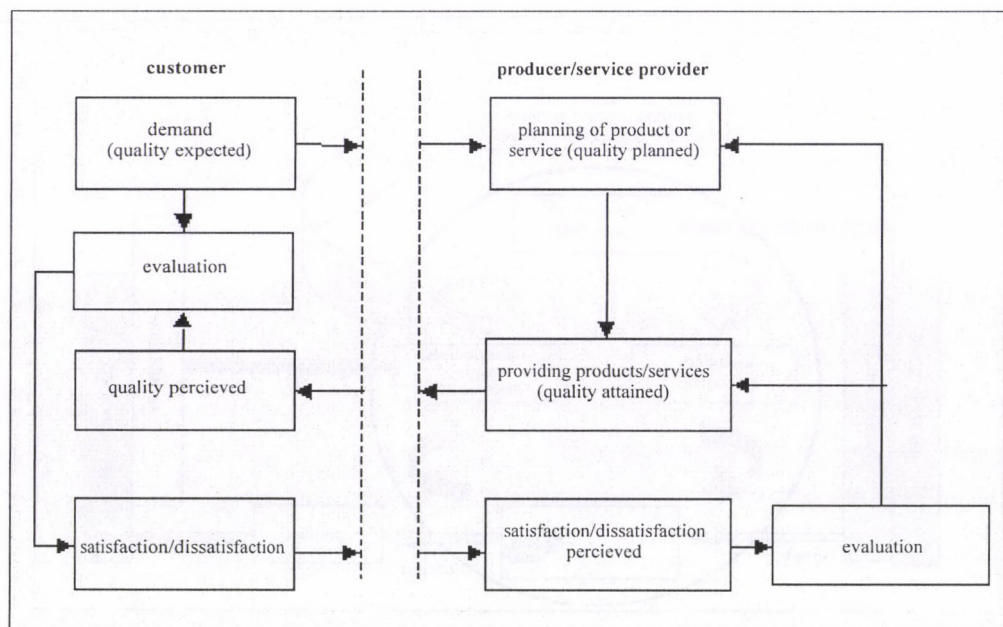

Figure 2 The information contact of customer and supplies

Measuring customer satisfaction

To be able to measure and compare it, customer satisfaction has to be made numerical. To convert qualitative factors to numbers, each response category has to be assigned a numerical value. The easiest way of transforming verbal scales into numbers is when customers directly place the evaluated characteristics on a numerical scale.

| un-acceptable | bad | | weak | | average | | good | | out-standing | |
|---------------|-----|---|------|---|---------|---|------|---|--------------|----|
| 0 | 1 | 2 | 3 | 4 | 5 | 6 | 7 | 8 | 9 | 10 |

Since characteristics are not of the same importance for the customer, they need to be weighted by ordering weight-factors to the values of each characteristic.

One of the possible ways of determining weighting factors is doing a paired comparison of characteristics, then transforming these corrected preference rates, eg. weighting on a scale between 1-10 [4].

Based on the values and weighting factors of the characteristics, two indices can be calculated:

a weighted satisfaction index:

$$Q = \sum_{i=1}^n q_i \cdot x_i$$

And an average weighted satisfaction index [5]

$$M = \frac{1}{n} \sum_{i=1}^n q_i \cdot x_i$$

Where: n - the number of evaluated characteristics

x_i - the satisfaction value of characteristic number i

q_i - the weighting factor (importance) of characteristic number i

Evaluation of results

When comparing indices of this type, we can raise the question, whether a high Q or M value can be accepted, if one or more of the characteristics are evaluated as "unacceptable". From the point of view of the customer, this means that he/she will not buy the product/service, irrespective of the values of its other characteristics, and the satisfaction index of this product/service is zero. Therefore it is useful to interpret the label "unacceptable" this way automatically. Thus, the principle of disqualification is put into practice during measuring.

There are several methods for showing the results of satisfaction-surveys: [6]

- Traditional evaluation of questionnaires: presenting distributions and rates by characteristics and overall results, in tables, graphics (column charts, pie charts etc.)
- Calculating indices (average and overall, etc.)
- Demonstrating each characteristic of a service in a coordinate system of satisfaction - importance
- The use of concurrent lines analysis to an evaluation by different customers and characteristics

References

- [1.] MACLAGAN, R.: Customer satisfaction monitoring in the document supply centre = *Managing Information*, / K. 8 sz. 1999. Oct. P. 44-47.
- [2.] VAVRAM, T. G.: Is satisfaction survey creating dissatisfied customers? = *Quality Progress*, 30.k. 12. sz. 1997. P. 51-57.
- [3.] DUTKA A.: *AMA Handbook for customer satisfaction*. NTC Business Books, Lincolnwood, Illinois, USA, 1999. 231. p
- [4.] *Minőségügyi rendszerfejlesztés. Módszertani segédlet. Kézirat. TÜV Rheinland Akadémia Kft. 2000. Május p. 65-69.*
- [5.] WOLTER, O.: Rechnet Sie TQM: Rentabilität und Zuverlässigkeit 43. K. 8. Sz. 1998. P. 912-916. Mutatószámok a TQM jövedelmezőségének mérésére, javítására. In: *MIME*, 1998. 11. P. 13-22.
- [6.] VERMES P.: A vevőelégedettség mérésének lehetőségei (Korreferátum az MTA Agrár-Műszaki Bizottsága 2000. Máj. 4-i ülésén)

Contents of N° 14/2001

| | | | |
|---|----|---|----|
| ENERGETICAL RESEARCH OF STRAW CHOPPING J. Bognár - P. Szendrő Szent István University, Gödöllő | 12 | DETERMINATION OF CRITICAL CONDITION OF CHOPPED STRAW MASSES WITH IMPEDANCE MEASURING L. Bense - P. Szendrő - Gy. Vincze Szent István University, Gödöllő | 51 |
| OUTFLOW AND ARCHING PROPERTIES OF GRANULOUS MATTERS (SUBSTANCES) Zs. Szüle - B. Csizmadia - P. Soós - E. Domonkos - I. Oldal Szent István University, Gödöllő | 15 | MODELLING OF FRUIT-PRODUCING FARMS WITH SPECIAL REGARD TO CAPITAL APPRAISAL OF INVESTMENT Katalin Takács-György Szent István University, Gödöllő | 54 |
| EXPERIENCES IN A LARGE - SCALE DAIRY FARM APPLYING PRECISION ANIMAL KEEPING TECHNIQUE L. Tóth Szent István University, Gödöllő J. Bak Hungarian Institute of Agricultural Engineering | 17 | INVESTIGATION OF THE BINDING AND DIFFUSION ENERGY OF WATER IN YEAST (SACCHAROMYCES CEREVISIAE) (OTKA T 032666) M. Neményi University of West Hungary L. Berecz Process Engineering of Agricultural Products, Research Group of the Hungarian Academy of Sciences | 56 |
| OBTAINED RESULTS OF DIESEL ENGINE DEVELOPMENT SO FAR AND THEIR EFFECT ON POWER TRANSMISSION A. Vas - Z. Lajber Szent István University, Gödöllő | 19 | THE INFLUENCE OF ROOT SYSTEM ON SOIL RESISTANCE B. Horváth - T. Major University of West Hungary, Sopron | 59 |
| COMPUTER AIDED PLANNING AND INFORMATION SYSTEM FOR PLANT PRODUCTION J. Benkő - I. Husti Szent István University, Gödöllő | 23 | FIXED BED DRYING CHARACTERISTICS OF YEAST (SACCHAROMYCES CEREVISIAE) IN DIFFERENT LAYER THICKNESS (OTKA T 032666) L. BERE CZ Process Engineering of Agricultural Products, Research Group of the Hungarian Academy of Sciences M. NEMÉNYI University of West-Hungary | 61 |
| STATISTICAL INVESTIGATION OF PARTICLE SIZE DISTRIBUTION OF SOME GRAIN GRIST E. Gyimes - R. Rajkó - A. Véha University of Szeged..... | 26 | APPLICATION OF ALTERNATING - CURRENT HYDRAULICS TO DEVELOP STUPLIFTING MACHINERY I. Czupy - Dr. B. Béla University of West Hungary, Sopron J. Lukács Mechanical Engineering of Miskolc University | 64 |
| ANALYSING OF THE CORN DRYING PROCESS J. Csermely - M. Herdovics Hungarian Institute of Agricultural Engineering | 28 | EXAMINATION OF FOREST STREAM SEDIMENT CHARACTERISTICS WITH PRINCIPAL COMPONENT ANALYSIS Z. Gribovszki University of West Hungary, Sopron | 67 |
| DETERMINATION OF INNER VISCOSITY OF V-BELT BY BENDING TEST L. Kátai - P. Szendrő - Gy. Vincze - I. Szabó Szent István University, Gödöllő | 31 | FOREST ROAD PLANNING WITH THE SOFTWARE ERDÜTTERV J. Péterfalvi - G. Markó University of West Hungary, Sopron | 69 |
| UP-TO-DATE TECHNOLOGIES OF GRAIN STORAGE Gy. Komka Hungarian Institute of Agricultural Engineering | 34 | PLANNING OF OPENING UP NETWORK WITH DIGITERRA MAP GEOINFORMATIK SOFTWARE M. Kosztka - G. Markó - J. Péterfalvi University of West Hungary, Sopron | 71 |
| SLURRY HANDLING BY SOIL FILTRATION L. Fenyvesi - L. Mátyás Hungarian Institute of Agricultural Engineering | 36 | TRIBOTESTING OF ENGINEERING POLYMERS L. Zsidai - G. Kalácska Szent István University, Gödöllő P. De Baets University of Gent, Belgium M. Kozma Budapest University of Technology and Economics..... | 74 |
| RELATIONSHIP BETWEEN APPLIED TECHNOLOGY AND QUALITY OF STORED CEREALS Gy. Komka Hungarian Institute of Agricultural Engineering | 38 | OPTICAL CHARACTERISTICS OF TRANSPARENT INSULATION MATERIALS M. Szűcs - I. Farkas Szent István University, Gödöllő | 77 |
| RELATIONSHIPS BETWEEN MECHANICAL AND NUTRITIONAL ASPECTS OF TUBULAR SYSTEM FOR FERMENTATION OF FEEDSTUFFS (OTKA T 030 031) Z. Bellus Hungarian Institute of Agricultural Engineering J. Schmidt University of West Hungary | 40 | PROCESS-ATTITUDE ANALYSIS OF SOIL TILLAGE SYSTEMS M. Birkás Szent István University, Gödöllő L. Csík MEZŐGÉP Ltd., Szolnok | 80 |
| COMPARISON OF CHAOTIC PARAMETERS OF PERIODIC SIGNALS L. Baranyai Szent István University, Faculty of Food Science, Budapest..... | 43 | MEASURING CUSTOMER SATISFACTION AS AN ELEMENT OF QUALITY EVALUATION P. Vermes - S. Szűcs Tessedik Sámuel College Mezőtúr, Faculty of Agriculture..... | 83 |
| GRINDING-ENERGETICAL INVESTIGATION FOR DETERMINATION OF BREAD WHEAT'S KERNEL HARDNESS A. Véha - E. Gyimes - E. Markovics University of Szeged..... | 45 | | |
| PRESSURE AND VELOCITY FIELD MEASURING IN THE ENVIRONMENT OF IMPELLER OF AXIAL FLOW FAN F. Szlivka Szent István University, Gödöllő J. Kópházi Budapest University of Technology and Economics..... | 48 | | |

**Contents of the
“Mezőgazdasági Technika”
periodical of the year 2001.**

**MEZŐGAZDASÁGI
TECHNIKA**
2100 GÖDÖLLŐ, TESSEDIK S.U.4.

N° 1

| | |
|--|----|
| The suspended front axle effects on the tractire specifications of New Holland TM 165 tractor (M. Szente - Z. Füzesi - J. Sláncz)..... | 2 |
| The globalization of the agricultural manufacturing is going on (J. Hajdú)..... | 5 |
| News from EIMA, Bologna (J. Hajdú)..... | 14 |
| Euro Tier 2000 (L. Tóth)..... | 23 |
| The cost of heat production from different materials (L. Gockler - P. Pecznik)..... | 32 |

N° 2

| | |
|--|----|
| Development strategy for the hungarian agriculture (I. Mucsi)..... | 2 |
| Technical background of the site-specific fertilizing (Zs. Pecze - M. Neményi - P. Á. Mesterházi)..... | 5 |
| News from EIMA, Bologna (J. Hajdú)..... | 14 |
| Silage cutters (J. Bak)..... | 17 |
| Leading test Institutes in Europe: CRA Gembloux, Belgium (S. Tissot - Gy. Tátrai)..... | 28 |

N° 3

| | |
|---|----|
| The newert result of the diesel engine developments (A. Vas)..... | 2 |
| The aims and tasks of agritechnical R+D at the millennium (L. Fenyvesi)..... | 5 |
| Advanced agricultural fires (G. Antos)..... | 29 |
| Leading test Institutes in Europe: EMA, Leganés/Madrid, Spain (J. L. Ponce de Leon - Gy. Tátrai)..... | 45 |
| New direction of the forage harvester (Zs. Kelemen - Zs. Kassai)..... | 52 |
| Tractor giants with rubber belt tracks (J. Hajdú)..... | 56 |

N° 4

| | |
|--|----|
| The effect of cutting direction movement of blade on the cutting resistance (T. Mezei)..... | 2 |
| The advantages of cattle keeping with bedding on sloped floor (D. Motika - L. Tóth)..... | 6 |
| Advanced agricultural tires II. (G. Antos)..... | 17 |
| The evaluation of conventional and reduced tillage systems by process point of view (M. Birkás - L. Csík)..... | 27 |
| SIMA Fair 2001 (Z. Bellus - M. Szente)..... | 34 |

N° 5

| | |
|---|----|
| Investigation and optimization of the swinging characteristics of a tractor with front axle suspension system. The effect of front axle suspension system on drawbar capacity (J. Schrottmaier - M. Nadlinger - M. Szente)..... | 2 |
| “Green card” (H. Ganzelmeier - Gy. F. Tátrai)..... | 6 |
| How do we harvest of grain crops? (I. Sörös)..... | 12 |
| Fans for cooling of dairy cows (J. Bak - L. Tóth)..... | 17 |
| AGRO+MASHEXPO 2001 (A. Horváth)..... | 22 |
| SIMA 2001 - The innovation trend of the agricultural machinery (Z. Bellus - M. Szente)..... | 26 |

N° 6

| | |
|--|----|
| Investigation on soil compaction forecast (M. Birkás - L. Csík)..... | 2 |
| Animal husbandry machinery on the AGROMASHEXPO (L. Tóth)..... | 6 |
| Metal sticking by adhesive and measuring its working load (S. Szűcs)..... | 17 |
| INTERVITIS - INTERFRUCTA: The three-yearly review of vine- and fruct growing machinery (Gy. Tátrai)..... | 22 |
| Machinery investment in the hungarian agriculture (2000) (J. Hajdú)..... | 24 |
| Machinery cost in the basic farms of FVMMI (L. Gockler)..... | 28 |

N° 7

| | |
|---|----|
| Examination of thermal load caused by bending of V-belt (L. Kátai)..... | 2 |
| Development of measuring instrument for determination of frictional resistance (Z. Csizmazia - B. Balló - F. Kasza - N. I. Polyák - Z. Hagymássy - B. E. Anca - K. Á. Gindert)..... | 4 |
| Field demonstration of up-to-date nutrient distributors (S. Soós)..... | 12 |
| Manure spreaders (Zs. Kassai)..... | 19 |
| AGRO - 2001 Exhibition on the occasion of the birthday of Kiev (L. Fenyvesi - Gy. Tátrai)..... | 30 |
| Changing of the agricultural machine stock on the basis of Amö 2000 (L. Gockler)..... | 35 |

N° 8

| | |
|--|----|
| Requirements for the evaluation of straw chopper operation (J. Bognár - P. Szendrő)..... | 2 |
| Dynamic technical development in the IKR (G. Antos)..... | 5 |
| Slurry injectors (Zs. Kassai)..... | 23 |
| Technical extension activity in the FVMMI (L. Fenyvesi)..... | 38 |
| Development of harvesting and material handling technology in the vineyard (L. Némethy - J. Deákvári)..... | 40 |
| Tractor business in West-Europe (1999-2000) (J. Hajdú)..... | 44 |

N° 9

| | |
|---|----|
| Distribution and effect on the soil structure of slurry, using in conservation tillage (L. Fenyvesi - Zs. Kelemen - L. Mátyás)..... | 2 |
| Drilling machines (J. Füzy)..... | 17 |
| Technical and feeding aspects of forage making (Sz. Orosz - Z. Bellus)..... | 26 |
| Straw - the universal hy-product (J. Bognár)..... | 29 |
| The situation of hungarian agricultural machine park, the real chance for its renewing and developing (L. Gockler)..... | 32 |

N° 10

| | |
|--|----|
| Modern grain storage technologies (Gy. Komka)..... | 2 |
| The first 600 kW power wind turbine in Hungary (L. Tóth - G. Horváth - G. Tóth - B. Stelczer)..... | 4 |
| Bábolna Farm Progress Show (A. Horváth)..... | 12 |
| Maize cutting headers (Zs. Kassai - Gy. Mészáros)..... | 17 |
| John Deere Show in Sevilla (A. Horváth)..... | 22 |
| Tillage 2001 - Tillage field show in England (M. Birkás)..... | 30 |

N° 11

| | |
|--|----|
| Developing the bale-wrapping as an up to date storage method (Z. Bellus - Sz. Komlósne Orosz)..... | 2 |
| New combine harvesters from John Deere (I. Sörös)..... | 12 |
| Automatic washers for milking machines (J. Bak)..... | 17 |
| New CX combine harvesters from New Holland (J. Hajdú)..... | 22 |
| National ploughing championship at Bóly (I. Jóri J. - Z. Sebestyén)..... | 30 |
| Agricultural Engineering Conference of Central and East European Countries (Gy. Tátrai)..... | 33 |

N° 12

| | |
|---|----|
| The role of building siting in the Solar energy utilization of glass-houses (M. Szabó)..... | 2 |
| Automatic washing devices for milking (J. Bak - L. Tóth)..... | 17 |
| Novelties from Bologna Fair (Gy. Tátrai)..... | 22 |
| Novelties from Agritechnica 2001 (A. Horváth)..... | 24 |
| Field research of reversible ploughs with conventional and slat-moldboards (S. Soós)..... | 28 |

Do you want to know more from
Hungarian Agriculture Machinery!

SENDTMIS ORDER FROM TO:

The Hungarian Agricultural Machinery Journal
H-2001 Gödöllő, Tessedik Sámuel u. 4.

ORDER FORM

I want order the Hungarian Agriculture Machinery Journal
from day month 200.....

The subscription fee: 3240 HUF

Name:

Adress:

Code, City:

Country:

Date: day month 200.....

.....
signature

