

HUNGARIAN

AGRICULTURAL

ENGINEERING

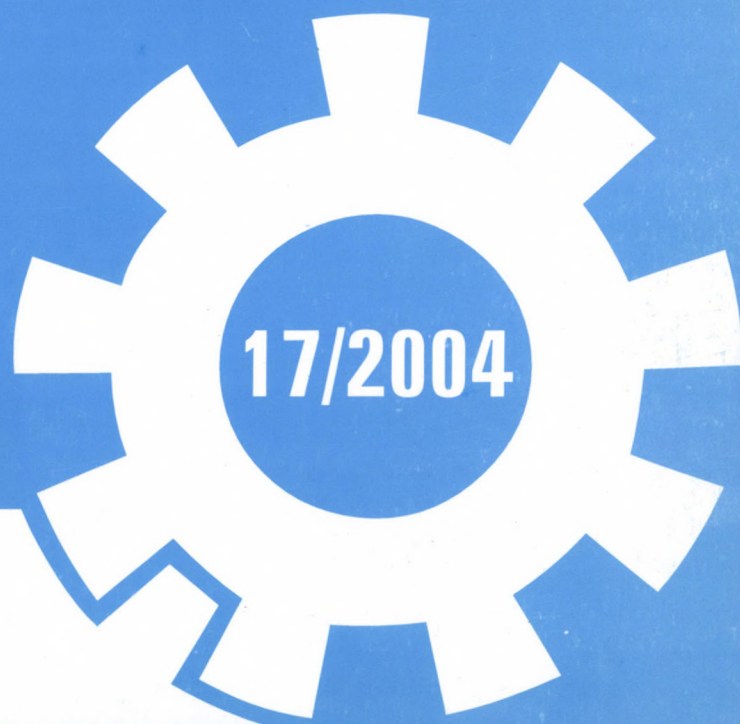

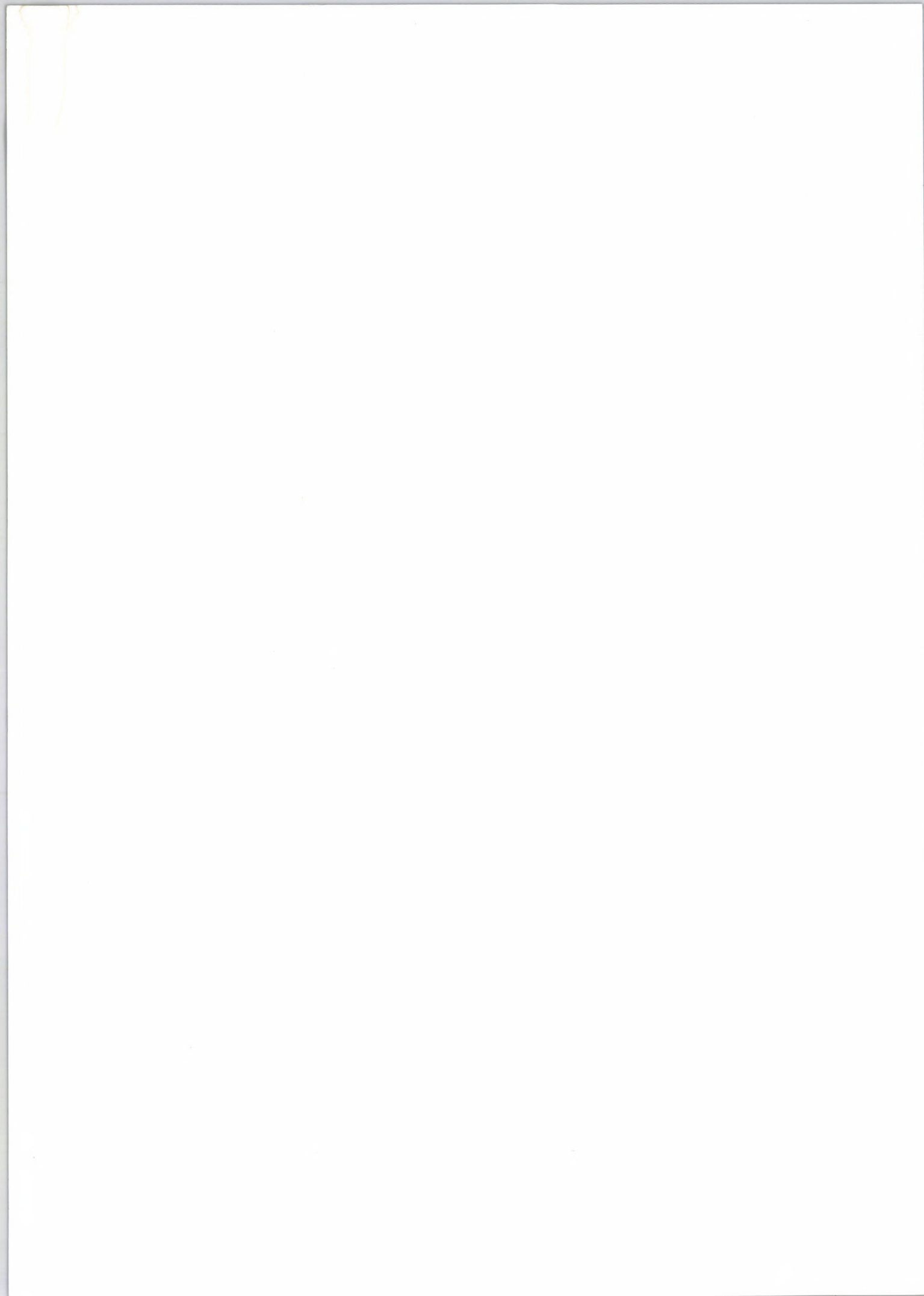



Hungarian Agricultural Engineering

N° 17/2004

PERIODICAL OF THE COMMITTEE OF
AGRICULTURAL ENGINEERING OF
THE
HUNGARIAN ACADEMY OF SCIENCES

Editor:

Prof. Dr. László TÓTH

Editorial Board:

Dr. Jenő CSERMELY

Dr. Imre DIMÉNY

Dr. István J. JÓRI

Dr. László FENYVESI

Dr. Péter SEMBERY

Dr. László TÓTH

Dr. János BEKE

Dr. Zdenek PASTOREK,
Czech. Republik

Dr. Jürgen ZASKE,
Deutschland

Dr. Vijaya G.S. RAGHAVAN,
Canada

Dr. Bart SONCK,
Belgium

Published by

Hungarian Institute of Agricultural Engineering

H-2100 Gödöllő, Tessedik S. u. 4.

Director: Dr. László FENYVESI



St. István University, Gödöllő
Faculty of Mechanical Engineering

H-2103 Gödöllő, Páter K. u. 1.

Dean: Dr. János BEKE



Gödöllő, December, 2004

PREFACE

The Agricultural Engineering Board of the Hungarian Academy of Sciences which supervises the development of this branch organises annually a conference at Gödöllő, which is the central place of the Hungarian agricultural scientific activity.

During the sessions, research scientist, developing engineers, experts of institutions engaged in agricultural engineering development strong in numbers the organizer, the hungarian universities and other higher grades of education, the research institutions: Hungarian Institute of Agricultural Engineering at Gödöllő, Faculty of Mechanical Engineering of the St. István University at Gödöllő and foreign guests give account of their results obtained in the research work and development of agricultural machinery.

This yearly English-Language publication the "Hungarian Agricultural Engineering", started at 1988, contains selected papers presented at the conference of 2004. We do hope that this publication will be found interesting to a big part of agricultural engineers.

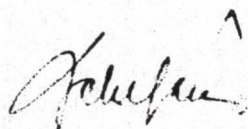

Dr. János Beke
Dean

Faculty of Mechanical Engineering
St. István University

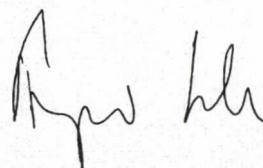

Dr. László Fenyvesi
Director

Hungarian Institute of Agricultural Engineering
Gödöllő

PART I.

ABSTRACT OF SELECTED PAPERS

FIELD RESEARCH FOR INVESTIGATION OF THE AGE-INDUCED CO₂ LOSS
L. Jón - J. Radics - I. Szűcs - I. Szűcs
Győr-Ménfőcsanak University of Technology and Economics
Hungarian Institute of Agricultural Engineering, Gödöllő
Széchenyi István University, Gödöllő

The progress in the field of the atmosphere has attracted interest in the present global warming and the possible effects of rising CO₂ levels on crop yield. In order to obtain improved agricultural practices and to reduce the negative effects of global warming, it is necessary to have a better knowledge of the atmospheric CO₂ concentration and its changes. The present investigation is devoted to the determination of the CO₂ concentration in the atmosphere above the crop canopy in the field. The results of the investigation are presented in this paper.

We have shown that the CO₂ concentration in the atmosphere above the crop canopy is higher than the CO₂ concentration in the atmosphere at the same height above the ground. The difference between the two concentrations is higher in the afternoon than in the morning. The CO₂ concentration in the atmosphere above the crop canopy is higher in the field than in the laboratory.

The results support the need for improved techniques of CO₂ enrichment in the greenhouse. The CO₂ concentration in the atmosphere above the crop canopy is higher in the field than in the laboratory. The difference between the two concentrations is higher in the afternoon than in the morning. The CO₂ concentration in the atmosphere above the crop canopy is higher in the field than in the laboratory.

COMPARISON TEST OF POWERSHIFT AND CONTINUOUSLY VARIABLE TRANSMISSIONS

Zs. Farkas - Gy. Károlyi
Budapest University of Technology and Economics

The power transmission system has been compared from the point of view of the CVT system. The new system could be a valuable alternative power transmission system which gives a high degree of flexibility in the selection of gear ratios. The CVT system is able to work in the optimum gear ratio range. About 10 years ago when the manufacturers have already produced a series of CVT systems with the stepless transmission, as an alternative to the powershift transmission which had been used in standard practice in tractor construction [1].

INFLUENCE OF THE FRONT AXLE SUSPENSION TO THE TRACTOR Traction CHARACTERISTICS

M. Szűcs - Zs. Kassai - H. László - F. Hrabovszky
Hungarian Institute of Agricultural Engineering, Gödöllő
BTL Austria

The earlier year, we determined the values of weight (mass) distribution and travel speed on the following in four wheel drive and rear wheel drive operation system (mode) 2000 tractor power transmission.

The tractor characteristics of the tractor:
- Tractor pull
- Tractor power
- Tractor efficiency

The last year we aim to determine the effect of front axle suspension upon the front axle and the whole tractor performance. The results of test show that the front axle suspension does not only in tractor's own convenience. The earlier years our company and the BTL together measured the rear and front suspension. These parameters show similar but not the effect on position of front axle suspension influenced of the tractor performance (tractor pull, drawing power) and the fuel consumption decreased.

PLANT-PERCEIVING SPRAYING MACHINE IN ORCHARDS

Gy. Gál - J. Kovács - J. Mészáros
Hungarian Institute of Agricultural Engineering, Gödöllő

The development of plant-perceiving spraying machines is one of the most important tasks of agricultural engineering. The main cause of these losses is that the soil of orchards is usually covered with vegetation and the insects spread on it. The main cause of these losses is that the soil of orchards is usually covered with vegetation and the insects spread on it.

The main cause of these losses is that the soil of orchards is usually covered with vegetation and the insects spread on it. The main cause of these losses is that the soil of orchards is usually covered with vegetation and the insects spread on it.

ENVIRONMENT FRIENDLY APPLICATION TESTS OF BRITISH INSECTICIDES AND PESTICIDES

A. Kovács - J. Pál - M. Kovács - J. Mészáros
Hungarian Institute of Agricultural Engineering, Gödöllő

The main cause of these losses is that the soil of orchards is usually covered with vegetation and the insects spread on it. The main cause of these losses is that the soil of orchards is usually covered with vegetation and the insects spread on it.

ABSTRACT OF SELECTED PAPERS

The main cause of these losses is that the soil of orchards is usually covered with vegetation and the insects spread on it. The main cause of these losses is that the soil of orchards is usually covered with vegetation and the insects spread on it.

The main cause of these losses is that the soil of orchards is usually covered with vegetation and the insects spread on it. The main cause of these losses is that the soil of orchards is usually covered with vegetation and the insects spread on it.

The main cause of these losses is that the soil of orchards is usually covered with vegetation and the insects spread on it. The main cause of these losses is that the soil of orchards is usually covered with vegetation and the insects spread on it.

The main cause of these losses is that the soil of orchards is usually covered with vegetation and the insects spread on it. The main cause of these losses is that the soil of orchards is usually covered with vegetation and the insects spread on it.

The main cause of these losses is that the soil of orchards is usually covered with vegetation and the insects spread on it. The main cause of these losses is that the soil of orchards is usually covered with vegetation and the insects spread on it.

FIELD RESEARCH FOR INVESTIGATION OF TILLAGE-INDUCED CO₂ LOSS

I. J. Jóri¹ – J. Rádics¹ – I. Pazsiczki² – I. Szabó² – Cs. Gyuricza³

¹Budapest University of Technology and Economics

²Hungarian Institute of Agricultural Engineering, Gödöllő

³Szent István University, Gödöllő

The increase in the CO₂ in the atmosphere has attracted interest due to the potential global warming and the prospects of using the soil as storage for carbon. Improved agricultural practices have great potential to increase carbon sequestration and decrease the net emission of carbon dioxide and other greenhouse gases. Information is needed on the short-term impacts of various tillage methods on C flow and dynamics within an agricultural production system.

We have done the first field research in Hungary to measure the effect of different primary tillage methods on the CO₂ flux from soil and to evaluate the effect of conservation tillage tools on short-term CO₂ emissions.

The results support increased adoption of new and improved forms of conservation tillage equipment (e.g. patented Komondor mulch cultivator) and offer a significant potential to preserve or to increase soil C levels and to decrease the carbon dioxide in the atmosphere.

Keywords: CO₂ flux, tillage, climate change, greenhouse gases

COMPARISON TEST OF POWERSHIFT AND CONTINUOUSLY VARIABLE TRANSMISSIONS

Zs. Farkas – Gy. Kerenyi

Budapest University of Technology and Economics

The tractor transmission system has been changed from the single sliding gear type to the electro-hydraulic and power shift and finally to the CVT types. The new system could be a variator or a hydrostatic power selection type, which have a capability to find the best speed value required by the implement in order to work at the optimum drawbar power [3]. About 30 years ago, nearly all manufacturers have already conducted a series of experiments with stepless transmissions as an alternative to the PowerShift transmissions which had come to be standard in practice in tractor constructions [2].

INFLUENCE OF THE FRONT AXLE SUSPENSION TO THE TRACTOR TRACTION CHARACTERISTICS

M. Szente¹ – Zs. Kassai¹ – H. Lampel² – F. Handler²

¹Non-profit Co. of HIAE for QT., Gödöllő

²BLT, Austria

The earlier years we determined the effects of weight (mass) distribution and travel speed on the followings in four wheel drive and rear wheel drive operation system (mode): Self traction power requirement,

The traction characteristics of the tractor:

- Drawbar pull,
- Drawbar power,
- Traction efficiency.

The last year was our aim, to determine the effect of front axle suspension upon the front axle and the whole tractor performance. The results of test show that the front axle suspension serve not only as farmer's own convenience. The earlier years our company and the BLT together measured the seat and cab suspension. These parameters show similar our results. The effect on position of front axle suspension increased of the traction performance (drawbar pull, drawing power) and the fuel consumption decreased.

PLANT-PERCEIVING SPRAYING MACHINE IN ORCHARDS

Gy. Dimitrievits – Z. Gulyás – L. Kovács – L. Magó

Hungarian Institute of Agricultural Engineering, Gödöllő

On horticultural plantations, significant losses, of 15-40%, sometimes of 80-90% may arise during the spraying procedures used nowadays. All these lead to substantial material and environmental losses.

The main cause of these losses is that the wall of leaves is usually broken, not contiguous on the orchards sprayed on. Owing to the peculiarities of various forms of planting, the different stages of development of the plants, the gaps in the rows of trees or stumps, a great deal of the disinfectant spray cannot gets to the surface of destination during continuous spraying, the majority gets to the soil, the rest of it is swept away or evaporated.

ENVIRONMENT FRIENDLY APPLICATION, TESTS OF DRIFTING INFLUENCED BY WEATHER CONDITIONS AND PROCEDURE

A. László¹ – B. Pályi¹ – M. Lönhárd¹ – Mrs. A. László²

¹VU GFA Department of Agricultural Engineering and Farm Mechanisation

²VU GFA Department of Chemistry and Microbiology

A criterion of sustainable agricultural development is that – it should not damage (strain) the environment unnecessarily, – it should apply environment-friendly, material effective, economical technologies,

– it should pay special attention to quality.

When it comes to the development of chemical plant protection, the research tasks of safer, target conscious distribution of chemicals cannot be evaded. From the point of view of application technology, this criterion means that no more than the minimum amounts of chemical agents necessary to reach the biologically desirable effect are to be distributed on the target area in the best possible distribution. Thus basically a smaller amount of chemicals needs to be used and less substance gets to places where it might have harmful consequences.

Losses (winds, thermals, evaporation, deposition in non-target areas are influenced mainly by the distribution technology, the sizes and physical properties of the particles, as well as the climate (temperature, moisture content of the air, wind velocity). Especially the smaller particles are in danger of being drifted by the wind. Thermal drifting is mainly caused by the dramatic fall of temperatures. Evaporation loss is significant in cases of high air temperature, low moisture content, small particle sizes, (when the vehicle is water without additives). Wind drift means the amount of chemicals leaving the area treated that gets deposited outside the target area or the part that covers a longer distance with the help of the wind. Since the 1980's several comparative studies dealt with tests of spray drifting, with different operation conditions and sample taking.

Within the tasks of the research topic we tested the drifting characteristics of different nozzles; the increase of particle sizes as a possible means of reducing drifting, and we further developed the measuring, data-processing and evaluation methods. We started work in 1999 and resumed it in 2002 with the support of OTKA T 34375 and TÉT Hungarian-German research cooperation projects.

FORCE-BASED ATOMIZATION THEORIES FOR SPRAY NOZZLES

I. Sztachó-Pekáry

College of Kecskemét

Two hypotheses were set forward for atomization: droplets separate laterally from liquid sheet or ligament

- 1.) against surface tension and
- 2.) against viscous shear.

The criterion has been determined of critical drop-size at which

shear and tension atomization mechanisms are equally effective. Existing literature confirms the theory as regards the effect of physical properties (surface tension, viscosity). The theory resolves the conflict in literature regarding the effect of viscosity, since it plays an important role only when shear principle is applied and not so effective when tension principle applies.

PLANT PROTECTION IN LINE WITH CONSUMER AND ENVIRONMENTAL PROTECTION

H. Ganzelmeier

Federal Biological Research Centre, Braunschweig

The re-organisation of consumer protection in Germany has led to a broad dialogue pointing in a new direction for future plant protection policies. There is no doubt that sufficient possibilities must be made available to the users of plant protection products to prevent and control harmful organisms and non-parasitic impairments in plants in order to secure plant protection effectively for the future. The protection of human and animal health as well as the environment is of equal importance, meaning that the risk in applying plant protection products has to be kept as low as possible. Therefore a reduction programme has still to be defined. It is a well known fact that Germany's agriculture cannot refrain from the use of modern technology if it is to stay competitive.

IMPROVING GERMINATION AND WATER ADDITION PARAMETERS OF SEEDS WITH ELECTROMAGNETIC TREATMENT

L. Bense – E. Joó – P. Szendrő – Gy. Vincze
Szent István University, Gödöllő

It has been researched in the framework of OTKA T043385 and NKFP4/030 programmes how the water structure is ordered by electromagnetic field and through this structure how the electromagnetic field affects biological processes of seeds. First of all germination and water addition processes of seeds has been studied. The germination process has been modelled with a simple enzyme-substrate autocatalytic reaction. According to the logistical graph this model predicts increasing germination in time, which has been confirmed by experiments. The water is structured by the treatment and this structure increases the inner osmosis pressure, which increases the volume and speed of water uptake. Experimental research of these models has been worked out in the case of vegetable seeds.

ON ISSUES OF FOOD – SAFETY OF MILK HANDLING BY MICROWAVE

K. M. Lukács – P. Sembery
Szent István University, Gödöllő

The physiological advantages of consuming milk and other dairy products are well known. In the raw milk, microorganisms in smaller or larger number always can be found that got from the udder at first and then, during the milking, the handling and the delivery (transport) into the milk. During the processing of the milk, the microorganisms or the great majority of them must be destroyed for the milk not to be harmful to the health of the consumers and, respectively, it to be keep able for a longer time and suitable for further processing. Several processes are known for decreasing the number of germ. These are the conventional heat-treatment (sterilization or pasteurization), the ionizer radiations and the processes basing on the microwave energy-transfer. In the present phase of this research, the investigations of the changes in the shelf life and the total germ count of the milk resulted by the effect of microwave treatment are dealt with, here.

SIMILARITY THEORY OF STRUCTURED AGRICULTURAL FLUIDS

L. Bense – E. Joó – P. Szendrő – Gy. Vincze
Szent István University, Gödöllő

Similarity theory is widely-spread in the fluid mechanics of Newton fluids. However structured agricultural fluids such as agricultural sewage are considered as non-Newton fluid of which similarity theory is not well-elaborated. In one of its research work the aim of MTA-SZIE Research Group for Modelling of Processed Plant Structures is to draft a non-Newton similarity theory which can be applied in the case of the most important structured fluid models. During the experiment the exact condition of similarity is given and the similarity criteria numbers dependent and independent on the material are being derived. Furthermore the similarity theory's basic principles of experiment planning is described then the opportunities of the method's practical application is demonstrated in the case of fluid mechanics problems of armatures and equipments such as pipeline, mixer, etc. applied in sewage treatment technology.

MECHANICAL FEATURES OF AGRICULTURAL PACKAGING FOILS

A. Csátár – Z. Bellus – L. Csorba

Hungarian Institute of Agricultural Engineering, Gödöllő

Our aim was to determine the strength and rheological features (creeping, relaxation) of foils applied in pressing machines that fill foil tubes. Tension tests were made according to the standards MSZ EN ISO 527-1 and MSZ EN ISO 527-3. For the rheological tests Poynting-Thomson and Burger's models were used.

HEAT TREATMENT OF THE MIXED FODDER

J. Csermely – M. Herdovics – Gy. Komka

Hungarian Institute of Agricultural Engineering, Gödöllő

Expanding and hygienization, as technological operations, seat tightly into the process of the production of mixed fodder where ensure the radical decreasing of the microbiological infection and the better conversion of fodders.

Additional energy demand of the hygienization is minimal. Expanding increases the specific energy demands of fodder production by 6-10 kWh/ton that means 20% of increasing. Operation of expanding improves the feed conversion generally by 4-7% because the digestibility of feed and the utilizable energy for animals increase alike. Operations of heat treatment increase the investment costs of mechanical technologies by 11-19%, while the operational costs by 17-20%.

POSSIBILITIES OF REDUCING EMISSIONAL ENVIRONMENTAL LOAD IN PIG HOUSING

I. Pazsiczki¹ – W. Berg² – L. Ducza³

¹Hungarian Institute of Agricultural Engineering, Gödöllő

²Institute of Agricultural Engineering Bornim (ATB)

³TSF College of Agricultural Sciences, Mezőtúr

In our research based on earlier examinations of environmental load in animal housing we objected to examine gas emission from pig excreta in laboratory. Aim of this study is doing basic research for different emission reduction technologies. Firstly we examined the technologies of covering among them. Two types of covering material were measured for several months (Pegülit and Perlit of trade name). Beyond that comparing emission measurements of pig slurry and solid excreta were

done by us. We got other and other emission and concentration values at different gases by using the value of control sample as a 100 %. From the point of reduction rate the perlite was the best at ammonia and carbon dioxide while a logical proportionality can't be found at methane.

SUMMER CLIMATIC PARAMETERS IN MODERN FREE BOX STABLE

J. Vegricht¹ – P. Hutla¹ – M. Češpiva¹ – J. Bak² – L. Fenyvesi² – I. Pazsiczki²

¹Research Institute of Agricultural Engineering, Prague

²Hungarian Institute of Agricultural Engineering, Gödöllő

Temperature-, relative humidity and emissions orientation measuring was carried out in 6 points in the stable (side box, opposite box in manure corridor and box in feeding the site in centre of the stable and in its sides). For ammonia and other gases concentrations measuring was utilized device 1312 Photoacoustic type Multi-Gas Monitor of INNOVA Air Tech Instruments firm with multi-channel sampling system 1309. The air temperature in the hall and its relative humidity was continuously recorded by the scanning apparatus COMMETER D3121 for registration, documentation and evaluation of temperature and humidity. The air temperature and relative humidity measured by the scanner COMMETER D3121 were continuously stored, too. The measuring apparatus meets requirements of EN ISO/IEC 17 025. The article utilized results of project solution NAZV MZe ČR No.QD 0176 and international bilateral Czech-Hungarian cooperation in the framework of the project MŠMTV KONTAKT CZ 8/2002.

NEW RESULTS IN THE FIELD OF RADIO-FREQUENCY IDENTIFICATION

L. Tóth – L. Fogarasi – N. Schrempf
Szent István University, Gödöllő

The so-called radio-frequency transmitters create such an electromagnetic field at the place of the identification that induces a voltage in the activating coil of the coil (receiver) being enough to actuate it. This unit sends back a signal series of modulated frequency or amplitude toward the receiving (relay) antenna of the recognizing logic unit that can make possible to identify the signals exactly.

In the practice, both the passive transponder (resting on an external electric power-resources) and the active one (using the energy of any energy-accumulator, e.g. dry battery of lithium) have been current. In the wider range, the passive transponders are manufactured because these constructions can be miniaturized and their efficient range relatively long. Today on the dairy farms, the transponders affixed to neck straps (collars) may be accounted conventional.

THE PHYSICAL CHARACTERISTICS OF HEMP SEED

Z. Csizmazia, Z. – N. I. Polyák
Centre of Agricultural Sciences University of Debrecen

Fibre reinforced polymers show excellent potentials for lightweight structures. In the paper we study natural fibre reinforced biopolymers. Hemp is one of the most important fibre plants. We also discussed the physical characteristics of hemp seed. Seeds are of special importance, as they come into close contact with various machines in the course of particle moving, seeding, spreading, harvesting, cleaning, drying, processing etc. The knowledge of the physical characteristics of seeds is essential for the constructors and operators. In this respect the size, size distribution, shape, mass, bulk density, real density, coefficient of friction and aerodynamic resistance of grains are of great importance.

EXAMINATIONS OF FALSE HEARTWOOD FORMING IN BEECH TREE BY MEANS OF COMPUTER-TOMOGRAPH

B. Biró¹ – J. Rumpf² – G. Bajzik³ – R. Garamvölgyi³ – Zs. Petrás³

¹ Forestry and Wood Corp. of Somogy, Kaposvár

² University of West-Hungary, Forestry College, Sopron

³ Diagnostics and Onkoradiology Institute of the University of Kaposvár

The facultative false heartwood forming of beech tree is one of today's most controversial forest management questions. The anomaly that causes changes in the structure and habit of the wood significantly reduces its economic value.

During the doctoral research we do complex surveying and analysis of false heartwood forming on a greater area – in the forest stands of the SEFAG Rt. that manages almost 80,000 hectares. The practical significance of the results is great.

Further ecological and economical concepts about the topic can only be made after putting into practice the anti-destructive way of identifying false heartwood in the wood. At the moment it is the greatest challenge of the research area to follow closely the heartwood forming process in time and space. Since the market trend of false heartwooded wood is likely to stagnate, it is ever significant to become acquainted with the possible ecological determinant factors.

Thanks to the Diagnostics Center of the University of Kaposvár in the winter of the year 2003 we were given the possibility to test computer tomography in false heartwood research as a possible anti-destructive wood examination method.

ANALIZATION OF THE POSSIBILITIES OF BASIC MATERIAL SUPPLY OF WOOD-BASED POWER PLANTS WITH USING FORESTRY INFORMATICAL DATABASE

B. Marosvölgyi – L. Jung, PhD. stud. – J. Kovács
University of West-Hungary, Sopron

The new area of the wood utilization for energy purposes is the wood-based electricity production. This can be achieved in great power plants. In Hungary three power plants change their energy carrier for wood, altogether 100 MWe performance. The supply of one power plant is an important exercise, and it cause new problems in the transporters. Great amount of wood is transported by the EGERERDŐ joint-stock company to the AES Power Plants in Kazincbarcika. The report shows what kind of information and database system was established and utilised by the EGERERDŐ for the basic material supply.

COMPONENT ANALYSIS OF PARTICLES OF RESIDUES ORIGINATING FROM CNC MILLING MACHINES CORRELATION WITH THE MILLING PARAMETERS

M. Varga – E. Csanády – G. Németh, PhD. Stud. – Sz. Németh, PhD. Stud.
University of West-Hungary, Sopron

During the operation of different wood working machines dust arises and depending on the applied technology gets into the air space of the work site or into the environment of the machines in smaller or bigger amounts. In case of total dust the limit value of flue dust permitted on work sites is 5mg/Nm³.

The measuring of dust amount is mandatory. Keeping the dust exposition limit values on work sites is not just a technical, but also an economic, economical issue. Taking the measurement results into consideration, we can deal with machine construction and pneumatics issues so that the dust load of work site does not exceed the permissible value.

In the last ten years, CNC processing centers became widespread in the woodworking industry. Machine constructions used in the machine industry, where only a small amount of chip is generated that cannot be removed pneumatically, were adapted for wood with little change. In case of woodworking machines, extraction systems had to be constructed for already existing machines, taking the high cutting speeds, the morphologically very different materials (light and dense soft- and hardwoods, composites), and the many different types of cutting tools employed, into consideration. As of today, dust and chip extraction from these machines has not been fully resolved. The tests described here, that assess the composition of chips and sawdust resulting from different cutting parameters, are part of a preliminary study aimed at revealing certain relationships that may help creating an efficient extraction system for such machines.

DETERMINATION OF THE ROLLING RADII IN THE INTERACTION OF A PNEUMATIC TYRE AND DEFORMABLE SOIL

P. Kiss

Szent István University, Gödöllő

Several rolling characteristics can be examined simultaneously by means of a suitable model representing the interaction of a pneumatic tyre rolling on deformable soil. The rolling radii can be distinguished, namely: the radius which develops due to wheel slip; the radius defined by the kinetics of the interaction; and the distance between the centre of the wheel and the bottom of the tyre. These three separate radii vary in time while rolling takes place. Because of the varying nature of these values one can only obtain them using dynamic measurements. This paper describes how these radii vary during rolling and discusses their interdependence.

WHY IS THE MECHANISATION OF HUNGARIAN SMALL AND MEDIUM SIZE FARMS SO DIFFICULT?

I. Husti

Szent István University, Gödöllő

In the Hungarian agriculture, after the transition, the role of small and medium-size enterprises has increased and presumably the situation will not be changed basically after joining the European Union.

The lecture deals with one of the most important issues of small and medium farms, namely with mechanisation and the problems of mechanisation. First the lecture analyses shortly the present situation and then deals with the preparation of machine-procurement decisions, and after that it deals with the difficulties and economical problems of the reasonable use of machines. The economic significance of mechanisation will not decrease in the future and therefore it worth while considering the best possible solutions for the economical and reasonable usage of farm machines. The lecture is going to define the diagnosis and to give guidelines to the therapy.

CONTROLLING OF ENERGETIC WIND MEASUREMENT (CALIBRATION OF CUP ANEMOMETERS)

N. Schrempf – L. Tóth

Szent István University, Gödöllő

One of the goals of the energetic wind measurements being carried out for several years in Dept. of Agroenergetics (Szt. István University, Hungary) was the construction of a wind tunnel that is suitable for calibrating anemometers and it is in accordance with the international standards.

DYNAMIC SURFACE FIRMNESS MEASUREMENT OF HIGH PRECISION

J. Felföldi – A. Fekete – V. Muha
Corvinus University of Budapest

Among the dynamic texture assessment methods the acoustic response method is known about its excellent reproducibility and accuracy. However the impact methods – suitable for surface tests of much wider range of products – have generally relatively high (10-20%) repetition error similarly to the traditional, compression based surface firmness assessment methods. Therefore a computer controlled impact test system was developed at the Department of Physics and Control for methodological investigation of the impact method and for analysis of the causes of the high variability. The impact force and position can be adjusted. Besides the methodological analysis the system was found to be suitable for detection and characterization of small scale surface changes (e.g. analysis of the non-destructivity of a load, spatial domain or time domain analysis of the effect of a mechanical stress, etc.).

TEXTURE PROPERTIES OF HORTICULTURAL PRODUCE

P. László

Budapest University of Economic Sciences and Public Administration

The quality of horticultural produce can be determined either by laboratory measurements, or by sensory qualification. Relationship was found between the two methods. Cucumbers and disease resistant apples varieties were tested. The experiments were sponsored by OTKA (TO30241).

First of all the consumers determined sensory points or sensory rank scores. During organoleptical analysis we measured the rheological properties. The sensory evaluation was done by Z. Kókai.

CORRELATION BETWEEN THE AGROPHYSICAL CHARACTERISTICS AND STRUCTURE-HARDNESS ON THE WHEAT KERNELS

A. Véha¹ – E. Gyimes¹ – M. Neményi²

¹University of Szeged Faculty-College of Food Engineering

²University of West-Hungary, Mosonmagyaróvár

Despite the fact that the three characteristic of wheat kernel measurements (length, width, thickness) are considered to be independent, thickness measurement can be estimated with good accuracy by a two-variable model, set up from length and thousand-kernel-weight values. This leads us to a verified correlation, which, however, is significantly modified by kernel hardness. For soft kernel samples the value of the determination coefficient ($R^2 = 0.72$) is higher than for hard kernel ones ($R^2 = 0.63$) but the relation is still **significant** and **strong** in both cases.

We also found that the relation between hectolitre weight (HLW) and porosity basically depends on kernel hardness. The constant of the linear regressive equation can be regarded as quasi equal, however, the difference between the regressive coefficients appeared to be ca. 15%, where correlation was identical. Thus the shape of wheat varieties with hard kernel texture is more suited to fill a given volume.

The efficiency of the flour milling process can best be measured by the volume of the end-product, that of the flour produced from a given volume of wheat. We measured the correlation between hardness index and flour yield (laboratory mill) and it proved to be significant and medium strong ($r=0.63$). We managed to further increase the accuracy of our estimates based

Abstract
The concentration of atmospheric CO₂ is increasing at a rate of about 1 ppm per year. This increase is due to the burning of fossil fuels and the release of CO₂ from the land. The concentration of CO₂ in the atmosphere is currently about 350 ppm and is expected to rise to 550 ppm by the year 2100. This increase in CO₂ concentration will have a significant impact on the climate of the planet.

The concentration of atmospheric CO₂ is increasing at a rate of about 1 ppm per year. This increase is due to the burning of fossil fuels and the release of CO₂ from the land. The concentration of CO₂ in the atmosphere is currently about 350 ppm and is expected to rise to 550 ppm by the year 2100. This increase in CO₂ concentration will have a significant impact on the climate of the planet.

Information is needed on both the short-term effects of agricultural management practices and the long-term effects of these practices on the global climate system. This information is needed to help farmers and policy makers make decisions about the best way to manage their land in the face of a changing climate.

Information is needed on both the short-term effects of agricultural management practices and the long-term effects of these practices on the global climate system. This information is needed to help farmers and policy makers make decisions about the best way to manage their land in the face of a changing climate.

Key words: Nitrate, CO₂, Rhyzotigation, Soil, Agriculture

Information is needed on both the short-term effects of agricultural management practices and the long-term effects of these practices on the global climate system. This information is needed to help farmers and policy makers make decisions about the best way to manage their land in the face of a changing climate.

Material and methods
The study was conducted at King's College London, UK. The study was carried out in a glasshouse and in the field. The glasshouse experiment was carried out in a glasshouse with a CO₂ concentration of 350 ppm. The field experiment was carried out in a field with a CO₂ concentration of 350 ppm.

Table 1. Soil conditions

Year	Soil condition	Operator	% of measurement
02.12.2001	23°C	Shirley	1
02.12.2001	23°C	Shirley	1
02.12.2001	23°C	Shirley	1

Soil conditions

The first study was carried out in a glasshouse with a CO₂ concentration of 350 ppm. The study was carried out in a glasshouse with a CO₂ concentration of 350 ppm. The study was carried out in a glasshouse with a CO₂ concentration of 350 ppm.

The second study was carried out in a field with a CO₂ concentration of 350 ppm. The study was carried out in a field with a CO₂ concentration of 350 ppm. The study was carried out in a field with a CO₂ concentration of 350 ppm.

PART II.

SELECTED SCIENTIFIC PAPERS

Working date	Machine	Operator	% of measurement
10	John Deere 7550	Shirley	1
11	John Deere 7550	Shirley	1
12	John Deere 7550	Shirley	1
13	John Deere 7550	Shirley	1
14	John Deere 7550	Shirley	1
15	John Deere 7550	Shirley	1
16	John Deere 7550	Shirley	1

The first study was carried out in a glasshouse with a CO₂ concentration of 350 ppm. The study was carried out in a glasshouse with a CO₂ concentration of 350 ppm. The study was carried out in a glasshouse with a CO₂ concentration of 350 ppm.

The second study was carried out in a field with a CO₂ concentration of 350 ppm. The study was carried out in a field with a CO₂ concentration of 350 ppm. The study was carried out in a field with a CO₂ concentration of 350 ppm.

The third study was carried out in a field with a CO₂ concentration of 350 ppm. The study was carried out in a field with a CO₂ concentration of 350 ppm. The study was carried out in a field with a CO₂ concentration of 350 ppm.

FIELD RESEARCH FOR INVESTIGATION OF TILLAGE-INDUCED CO₂ LOSS

I. J. Jóri¹ – J. Rádics¹ – I. Pazsiczki² – I. Szabó² – Cs. Gyuricza³

¹Budapest University of Technology and Economics

²Hungarian Institute of Agricultural Engineering, Gödöllő

³Szent István University, Gödöllő

Objectives

Greenhouse gases and tillage intensity

The concentration of greenhouse gases in the atmosphere has increased steadily since about 1850. A substantial part of the total increase so far has been attributed to deforestation, conversion on farmland, and other agricultural activities (Post et al., 1982.). CO₂ is the most important greenhouse gas, because increase in its concentration causes about 50% of the total radiative forcing (Rodhe, 1990). The concentration of CO₂ in the atmosphere was about 280 ppm in about 1850 and 365 ppm in 1996, and it is increasing at the rate of 0.5 %/yr. If this trend continues, CO₂ concentration will be 600 ppm during the 21st century (OSTP, 1997).

Improved agricultural practices have great potential to increase carbon sequestration and decrease the net emission of carbon dioxide and other greenhouse gases, but policy makers have not widely recognized this potential. Since the 1980s, considerable scientific information has been collated about the potential of agricultural lands to sequester C (Lal et al., 1995a, b, 1998a, b.). But the available information has not been synthesized in a form that policy makers and land managers readily can use to mitigate CO₂ emissions in relation to the potential greenhouse effect.

There is a definite need for information on the impact of tillage on CO₂ from soil and how farming practices can be managed to minimize impact on global climate change.

Information is needed on both the short-term effect of agricultural management decisions and the long-term effects, as they may affect global climate change. Direct evidence on the effect of tillage method on CO₂ flux rates is limited.

Over the past two decades, conservation tillage has evolved primarily for erosion control. However, recent concern for global climate change reemphasizes the importance of conservation tillage and how it can be implemented on many soils to help reduce soil C losses. While tillage and cultivation result in loss of soil C and nitrogen (Campbell and Souster, 1982; Mann., 1986), the direct influence of tillage on CO₂ flux is varied and highly interactive. Variation in the soil CO₂ flux can result from the interaction of many factors. Soil loosening should improve accessibility of oxygen necessary for organic matter decomposition and respiration resulting in CO₂ release.

Aim of the project

Information is needed on the short-term impacts of various tillage methods on C flow and dynamics within an agricultural production system. Our objective was to measure the effect of different tillage methods on the CO₂ flux from soil. Any increase in soil carbon has important benefits for the sustainability and productivity of the agro ecosystem. Many of the land management practices that favor carbon accumulation, like conservation tillage also prevent erosion thereby improving air and water quality. This has the potential to increase soil productivity and profitability of farming systems by increasing yields or reducing production.

Material and methods

Site description

This work was conducted clay loam soil at Enying Ltd. Farm (Table 1.). The study was initiated on July,2003 and finished on April, 2004.

Table 1 Site specification

No. of measurement	Operation	Weather condition	Date
1.	Stubble mulching on wheat stubble	Dry, sunny, 28°C	07.15.2003
2.	Primary tillage on corn stubble	Dry, windy, 20°C	09.23.2003
3.	Secondary tillage on corn field	Dry, windy, 23°C	04.29.2004

Study description

The first study area was planted to winter wheat on last decade of October(2002) and harvested on first decade of July. The short-term influence of tillage on soil CO₂ evolution was assessed by recording 2 series of successive measurements. Each series included a pre-tillage measurement to assess „base line” flux uniformity, followed by three different past-tillage measurement to compare fluxes along tilled and undisturbed plots.

The second study area was planted to corn on last decade of April(2003) and harvested on last decade of September. The short-term influence of primary tillage on soil CO₂ evolution was assessed by recording 2 series of successive measurements to compare fluxes using different equipments.

The secondary tillage treatment was done on primary tilled area at spring time (2004) using a seedbed maker machine (Table 2).

Table 2 Treatment specification

No. of measurement	Operation	Machine	Working depth, cm
1.	Stubble mulching	Rába-IH disc harrow+ Gütler roller	15
		Komondor mulch tiller	15
		Kverneland CLE chisel plough	25
2.	Primary tillage	Rába-IH disc harrow+ Gütler roller	20
		Kverneland BB 115 plough	25
		Kverneland CLE chisel plough	35
3.	Secondary tillage	Syncrogerm 6M seedbed maker	10

For the tillage treatment commercially available tillage implements were used. The tractor with tillage implement made a pass through the plot and within one minute the portable chamber was moved over the measurement area and gas exchange measurement completed. A series of two measurements were made to get the initial flux of CO₂ immediately following tillage. The gas exchange measurements were repeated on a regular cycle so that each of measurement areas was visited at least once a quarter (half) hour for up to three hours after initial tillage.

Instrumentation

Soil CO₂ fluxes were measured in situ using an INNOVA 1312 Multi Gas Monitor with closed chamber system. The atmosphere immediately above the soil surface is enclosed by the chamber and the change in concentration of CO₂ every 15(30,60) minutes after closure measured (Figure 1). This change is a result of net emission from the soil and enables gas flux to be determined. Because of the high cost of INNOVA

system for the second and third study – after a field validation process – we used the TESTO 535 CO₂ tester.

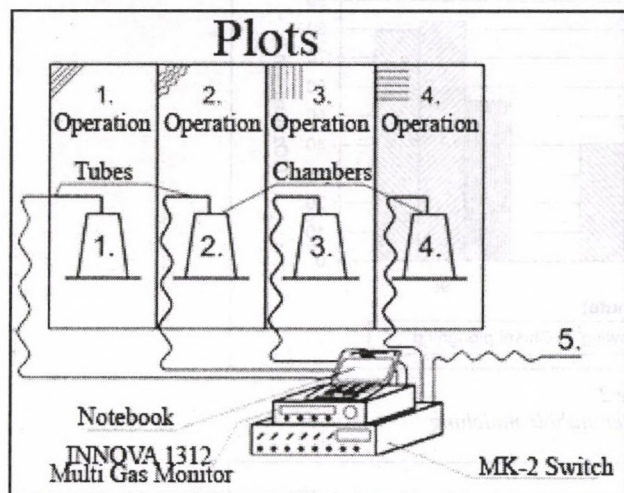

Figure 1
Measuring system

Result and discussion

Stubble mulching

The CO₂ flux as a function of time for each tillage treatment in the first 2 hours can be compared on Figure 2.

Immediately after tillage was not observed significant differences. The CO₂ flux measured during 85-105 minutes shows some advantages for mulch tiller where the rear part (spring loaded crumbler) of the machine was effective.

Primary Tillage

The CO₂ flux as a function of time for each tillage treatment in the first 2,5 hours can be compared on Figure 3. In the case of chisel ploughing the emission was measured along the shank and between of them and was counting an average.

The higher CO₂ fluxes were related to depth and intensity of soil disturbance that resulted in a rougher surface and larger voids. The initial fluxes were relatively large from the moldboard plough surface and the increasing was not high. The fluxes from the chisel plough and disc harrow surface showed a similar trend.

Secondary tillage

The CO₂ flux after seedbed making as a function of time for each primary tillage pre-treatment in the first 2 hours can be compared on Figure 4.

The long-term (seasonal) effect of the different primary tillage was observed after seedbed preparation. All conservation tillage implements produced less CO₂ than the moldboard plough. Because of the conservation tillage implements were primary designed to leave crop residue on the surface they can have a second beneficial effect that results in less CO₂ loss.

Conclusions

Summarized the results were getting from the field research the following conclusions can be drawn:

- The methods and tools using for measuring of CO₂ emission need further developments to increase the accuracy of field measurement,
- The weather condition, first of all the temperature has a great influence on the soil CO₂ flux. Below 10°C has no significant differences between the different tillage methods,
- The intensive tillage, like moldboard ploughing that disturbs the soil to depths and leaves the surface rough can result in essential carbon loss, because the plough not only fractures and opens the soil which can allow fast CO₂ and oxygen exchange, but also incorporates residue into the soil which feeds a microbial population explosion. In the case of conservation tillage, most residues are left on the soil surface, so a small portion is in closed contact with the soil moisture and can be available to microorganisms,
- The order of different primary tillage implement by measured CO₂ fluxes : moldboard plough, chisel plough, heavy disc harrow and mulch tiller,
- These results suggest that selection of primary tillage implement that maintains surface residue and minimizes soil disturbance could help CO₂ loss.

Acknowledgments

The author wish to acknowledge the financial grant from the Ministry for Agriculture and Rural Development, the National Research and Development Programmes (OM) and the Hungarian Scientific Research Fund (OTKA).

References:

- [1] Campbell, C. A. - Souster, W.: Loss of organic matter and potentially mineralizable nitrogen from Saskatchewan soils due to cropping. *Can.J.Soil Sci.* 1982.62:651-656
- [2] Lal, R. - Kimble, J. - Levine, I. - Stewart, B. A. (eds): *Soils and global change*. CRC/Lewis Publishers, Boca Raton, FL. 1995a. 440pp.
- [3] Lal, R. - Kimble, J. - Levine, I. - Stewart, B. A. (eds): *Soil management and greenhouse effect*. CRC/Lewis Publishers, Boca Raton, FL. 1995b. 385pp.
- [4] Lal, R. - Kimble, J. - Follett, R. - Stewart, B. A. (eds): *Soil processes and the C cycle*. CRC Press, Boca Raton, FL. 1998a. 609pp.
- [5] Lal, R. - Kimble, J. - Follett, R. - Stewart, B. A. (eds): *Management of C sequestration in soil*. CRC Press, Boca Raton, FL. 1998b. 457pp.
- [6] Mann, L. K.: Changes in soil carbon storage after cultivation. *Soli. Sci.* 1986. 142:279-288.
- [7] OSTP. *Climate change. State of knowledge*. Office of Science Technology Policy. Washington, D.C. 1997. 18pp.
- [8] Post, W. M. - Peng, T-H. - Emanuel, w. R. - King, A. W. - DeAngelis, D. I.: The global carbon cycle. *Am. Scientist.* 1982.78.310-326.
- [9] Rodhe, H.: a comparison of the contribution of various gases to the greenhouse effect. *Science.* 1990.248:1217-1219.

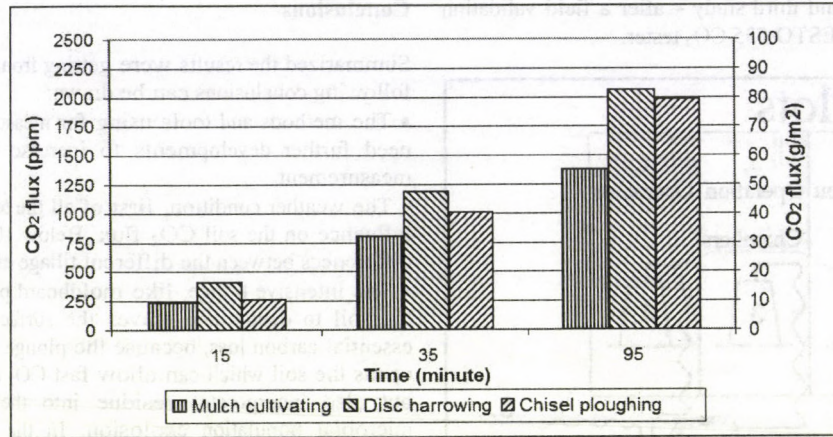

Figure 2
CO₂ flux versus time after stubble mulching

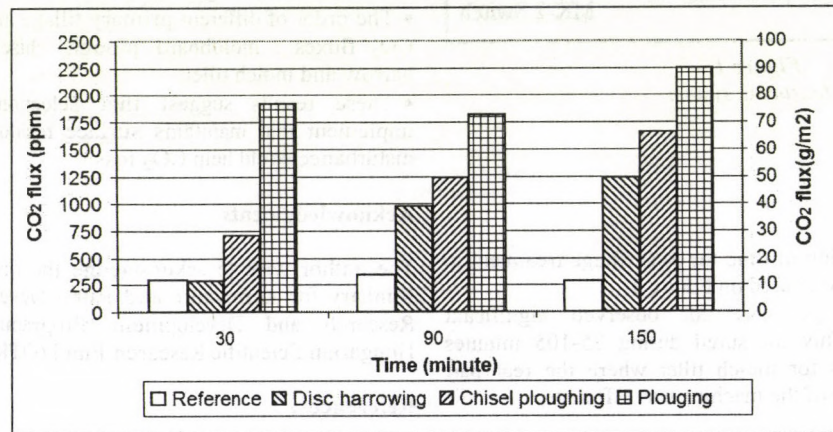

Figure 3
CO₂ flux versus time after different operations

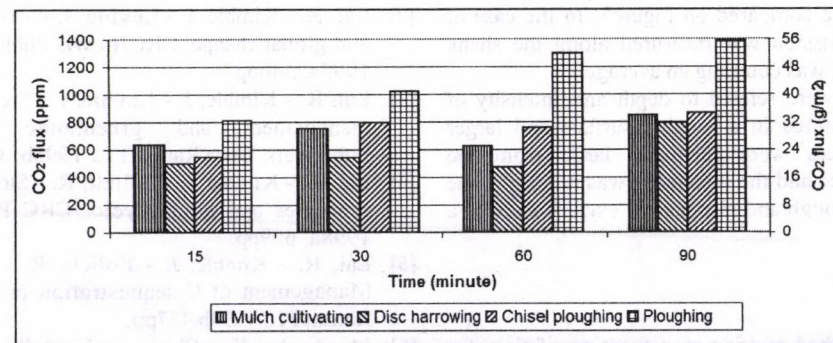

Figure 4
CO₂ flux versus time on different plots

COMPARISON TEST OF POWERSHIFT AND CONTINUOUSLY VARIABLE TRANSMISSIONS

Zs. Farkas – Gy. Kerenyi
Budapest University of Technology and Economics

1. Introduction

The tractor transmission system has been changed from the single sliding gear type to the electro-hydraulic and power shift and finally to the CVT types. The new system could be a variator or a hydrostatic power selection type, which have a capability to find the best speed value required by the implement in order to work at the optimum drawbar power [3]. About 30 years ago, nearly all manufacturers have already conducted a series of experiments with stepless transmissions as an alternative to the PowerShift transmissions which had come to be standard in practice in tractor constructions [2].

2. The test methods

The investigation of driving systems of tractors is a complex, time-consuming and costly project and can be completed by field or bench tests. Traditionally these tests are based on measurement, but the result of the new development of information technology [1], the simulation method can be extended to all levels of the driving system examinations. This new method can be cost saving and give a chance to optimize the testing system [4].

A program for the field test was developed, which is a first step of the complete comparison. The two basic level of the examination series are the tractor drawbar test and tractor-implement test. The tractor-implement test level was also separated to transport test, high power operation - and PTO operation test.

2.1. Tested tractors

These were done on CASE CS 150 and CASE CVX 150 type tractors. The CASE CS 150 has a SYNCROMESH 4 range gears electro hydraulic controlled PowerShift transmission, which has 4 range gears with 6 synchro. gears included. The Steyr hydrostatic-mechanic power split, stepless transmission is used in the CASE CVX 150 tractors. The investigated tractors – because of the test methods developed by us – have same engine power ($P_{nom}=108$ kW), tyre dimension and pressure, and their axial load was also the same by extra weighting. Due to these specifications the tested tractors were the same only the transmission was different.

2.2 The developed track for field test

The transport test was prepared on a special flat field test track (Cegléd Cifrakert). The test track contains wheat stubble section, ground section and concrete section (figure. 1).

2.3. The developed simulation program

The aim of the project is to create a simulation program to compare different transmission systems based on the drawbar and transport field tests. Trought the measurements the tractors were driven along the test track. In the case of CVT the effect of the full load potentiometer and the cruise control were analyzed too. For the transport test two-axle trailer (HW 8011 type) was used as a load.

The following data were monitored and recorded:

Time	[s]
Engine speed	[1/sec]
Speed	[m/sec]
Pull	[kN]

Fuel consumption	[l/h]
Rear axle speed	[1/perc]
Trigger	[V] to separate the test sections and drag strategies

For the signal processing and data evaluation a CATMAN-Spider8 system was used.

To analyse and present the data, a simulation software was developed. The user interface of the software can be seen on fig. 2. In the two top diagrams the engine characteristics are being displayed, and fuel consumption data is indicated when in operation. In the right side the actual values of the measured and calculated data (e.g.: transmission ratio, distance) can be seen. On the bottom left corner you can see different diagrams, like the speed as a function of rpm, the speed as a function of time, the transmission ratio as a function of time, the rpm as a function of time, the fuel intake as a function of distance. On figure 3. can be seen on user interface of the CVT PowerShift Simulator program in case of accelerating the tractor from 0 to 35 km/h.

3. Result and discussion

From the measured data the maximum speed [km/h], the elapsed time [s], the fuel consumption [l] and fuel consumption ratio – (necessary fuel amount for acceleration of a unit weight) created for the better comparison – were with the developed simulation program represented. The results of the program are shown in Table 1-2 for unloaded and loaded case. The results shown below belong to acceleration on concrete section.

Table 1 The results of the developed program in unloaded case

Type of Tractors	Position of full load pot. meter	Speed [km/h]	Elapsed time [s]	Distance [m]	Fuel consumption [l]	Fuel consumption ratio
CASE CS 150	-	42,14	17	127,7	0,1299	0,073
CASE CVX 150	0	30,03	18,16	152	0,134	0,0535
CASE CVX 150	0	42,14	13,16	87,5	0,095	0,0534
CASE CVX 150	10	52,03	17,46	155,9	0,131	0,0498
CASE CVX 150	10	42,15	10,4	61,2	0,088	0,0495

Table 2 The results of the developed program in loaded case

Type of Tractors	Position of full load pot. meter	Speed [km/h]	Elapsed time [s]	Distance [m]	Fuel consumption [l]	Fuel consumption ratio
CASE CS 150	-	33,53	22,4	133,7	0,1679	0,149
CASE CVX 150	0	39,11	10,68	39,4	0,0691	0,0451
CASE CVX 150	0	33,59	7,62	20,12	0,045	0,0398
CASE CVX 150	10	39,35	12,76	46,3	0,071	0,0458
CASE CVX 150	10	33,52	9,2	24	0,047	0,0418

4. Conclusions

Conclusions considering the experimental results are follows: The created method and simulation program is applicable to compare the tractors with different transmissions systems, the tractors with CVT have better acceleration behavior and lower fuel consumption, the difference between the PowerShift and CVT in the case of loaded test conditions were the most significant, the effect of full load potentiometer of CVT in the case of unloaded test conditions were the most significant, by modeling of tractor transmission systems and using experimental parameters the simulation of the transmission types in operation have been achieved. By the application of the experimental results and the simulation model the optimization of the operational parameters can be accomplished for PowerShift and CVT transmissions.

Acknowledgements

The authors wish to acknowledge the financial grant from the Ministry for Agriculture and Rural Development, the Hungarian Scientific Research Fund (OTKA) and the technical assistance for the representative manufactures of tractor.

References

- [1] Günter Spur, Frank-Lothar Krause: Das virtuelle Produkt Management der CAD-Technik, Carl Hauser Verlag München Wien, 1997
- [2] M.Lober: The future belongs to stepless transmissions, Agritechnika 2001
- [3] K. Th. Renius - R. Resch: Tractor Engines and Transmissions, Yearbook Agricultural Engineering, Band 14, 2002
- [4] Zsolt Farkas - István J. Jóri - György Kerényi: The application and modelling possibilities of CVT in tractor, 5th International multidisciplinary conference, Baia Mare 2003. may 23-24, Part II 145-150p

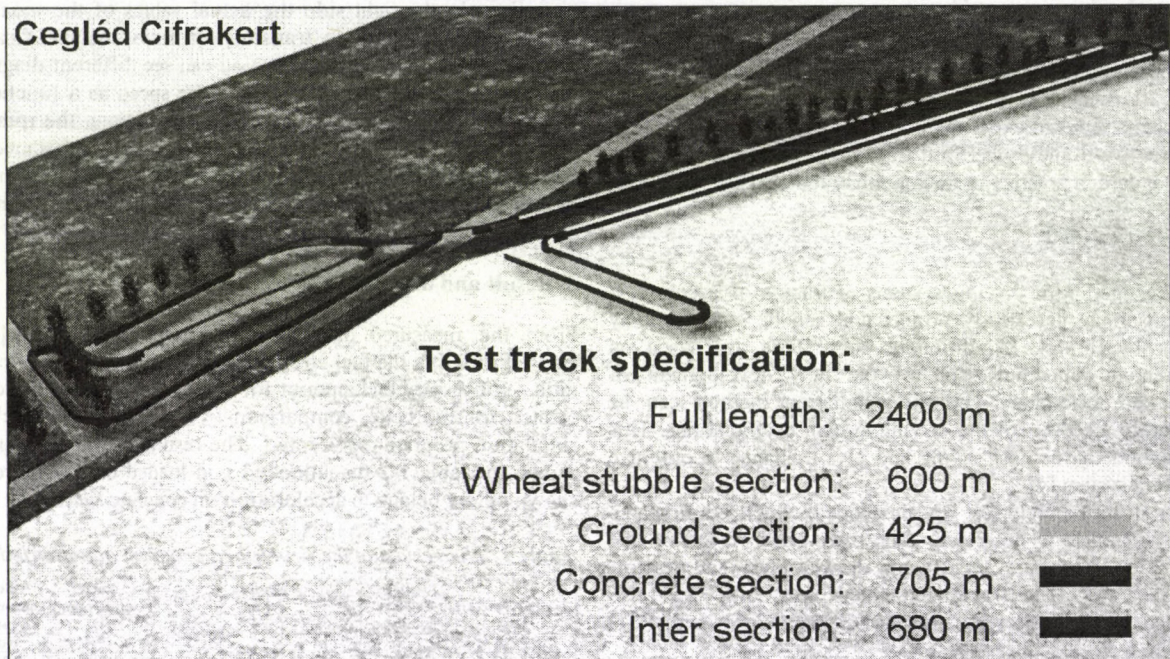

Figure 1
The test track

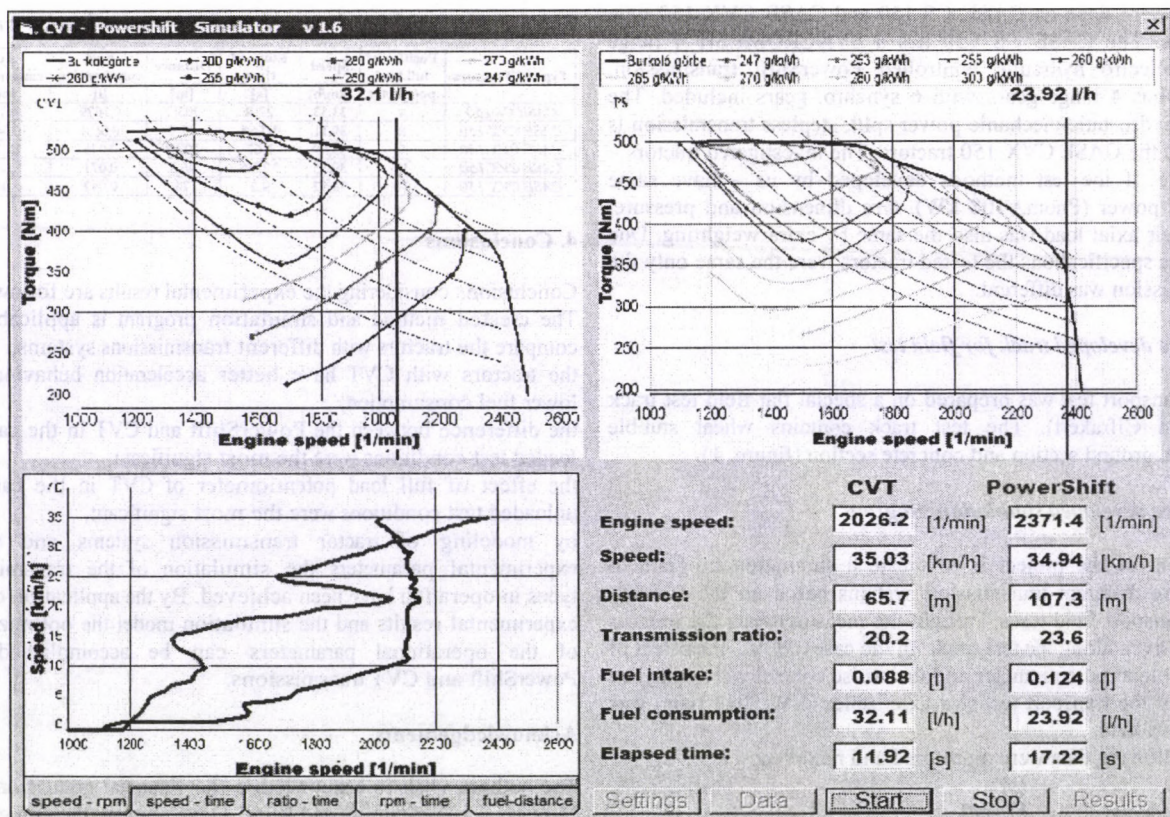

Figure 2
User interface of the developed simulation software

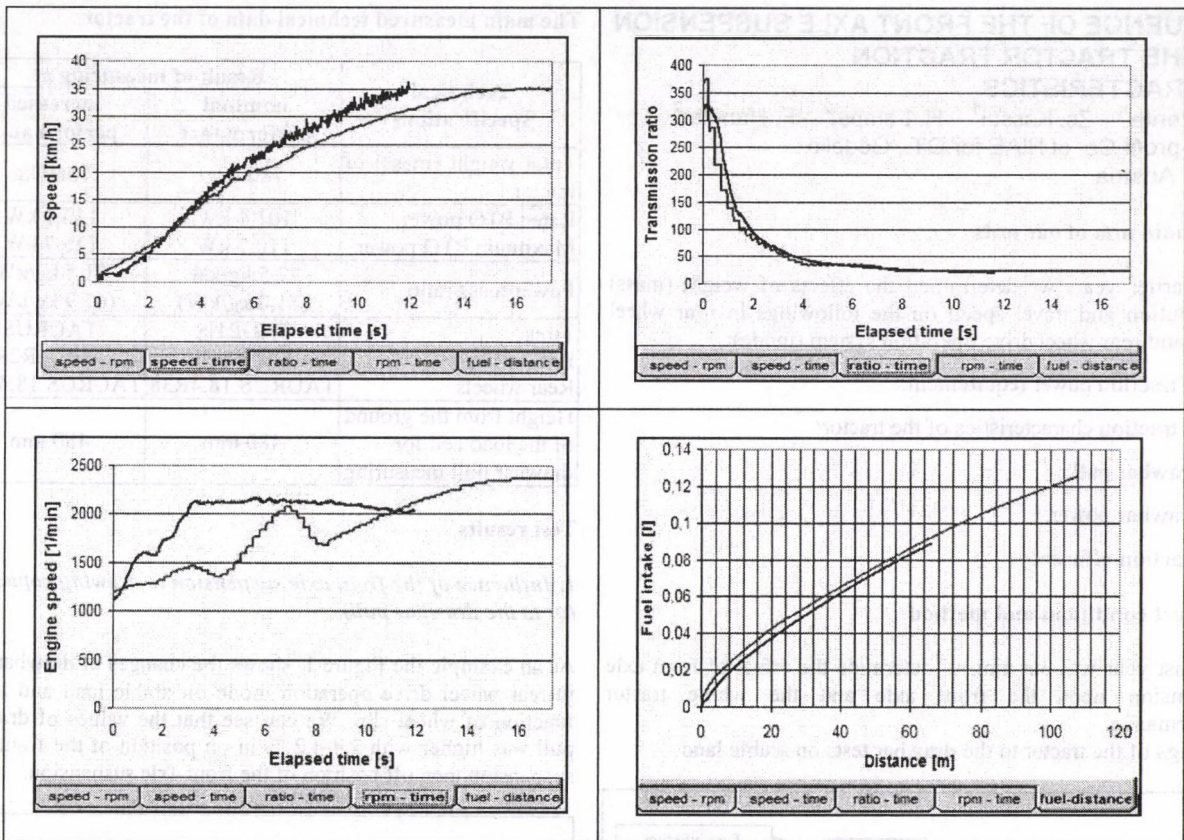
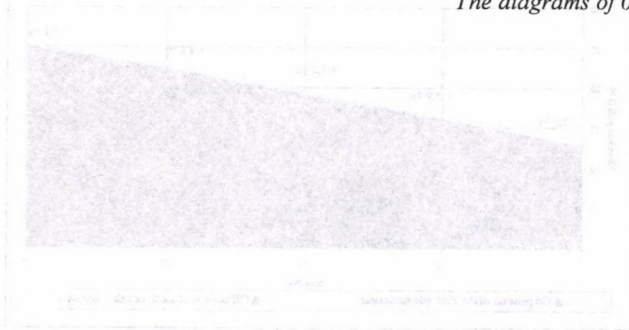
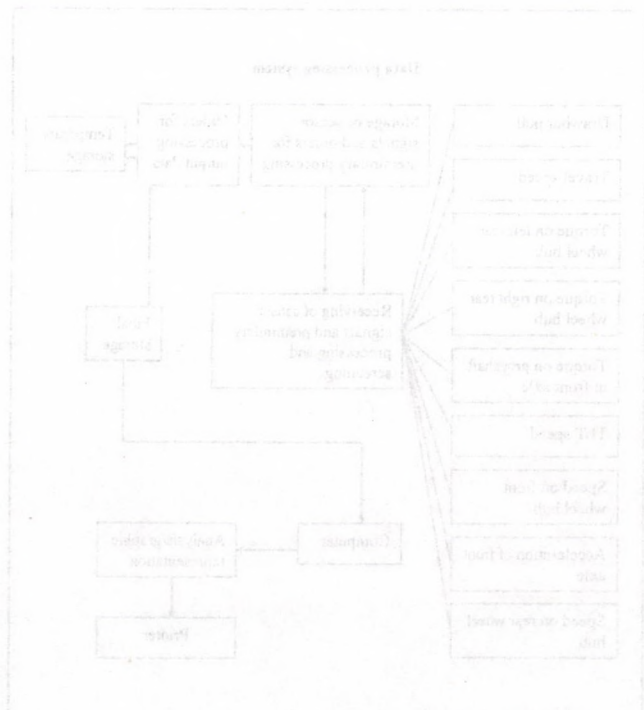
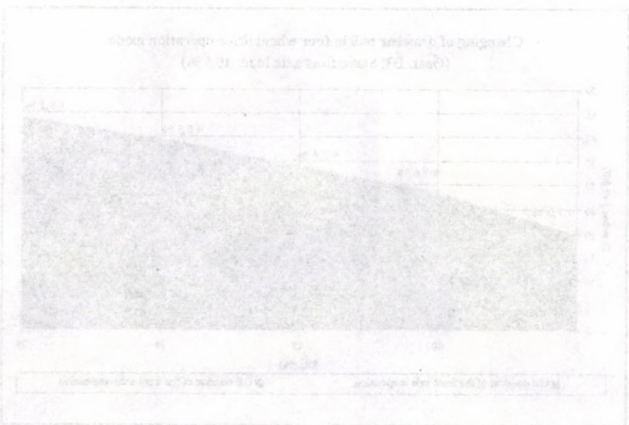

Figure 3
The diagrams of 0-35 km/h acceleration



The next figure shows the same adjustment parameters in four...
which drive operation mode. We can see that the values of...
thrust was higher with 7.0-0.2 in an operation of the...
from the suspension than all position of the front...
suspension.



INFLUENCE OF THE FRONT AXLE SUSPENSION TO THE TRACTOR TRACTION CHARACTERISTICS

M. Szente¹ – Zs. Kassai¹ – H. Lampel² – F. Handler²

¹Non-profit Co. of HIAE for QT., Gödöllő

²BLT, Austria

The main aim of our tests

The earlier years we determined the effects of weight (mass) distribution and travel speed on the followings in four wheel drive and rear wheel drive operation system (mode):

- Self traction power requirement,
- The traction characteristics of the tractor:
 - Drawbar pull,
 - Drawbar power,
 - Traction efficiency.

The test conditions and method

The last year was our aim, to determine the effect of front axle suspension upon the front axle and the whole tractor performance.

Settings of the tractor to the drawbar tests on arable land:

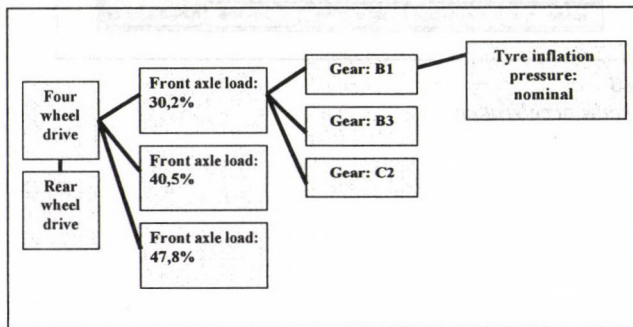

Scheme of the measurement and data processing:

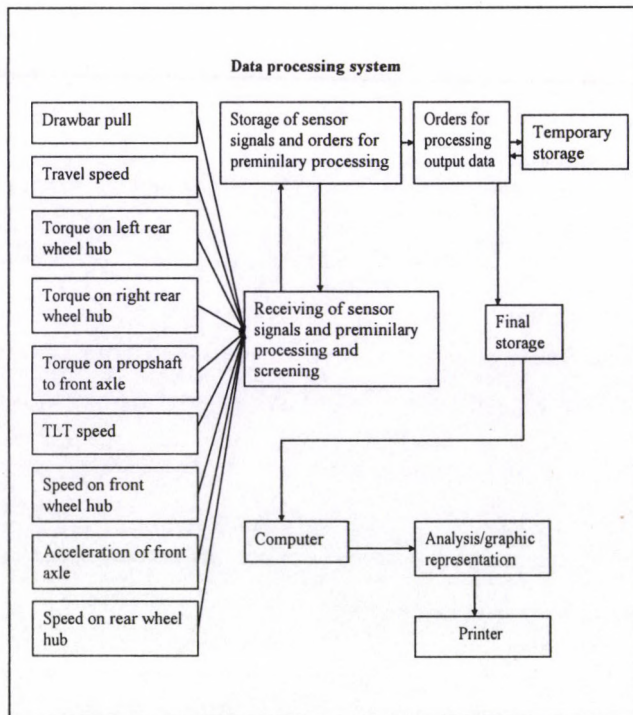

The main measured technical data of the tractor:

Technical specifications	Result of measuring at	
	nominal performance	increased performance
Total weight (mass) of tractor	7860 kg	7860 kg
Rated PTO power	101,4 kW	110,1 kW
Maximum PTO power	110,7 kW	115,7 kW
Power/mass ratio	77,5 kg/kW (71,0 kg/kW)	71,4 kg/kW (67,9 kg/kW)
Tires	TAURUS	TAURUS
Front wheels	420/70R28	420/70R28
Rear wheels	TAURUS 18,4R38	TAURUS 18,4R38
Height from the ground of the load cell for drawbar pull measuring	480 mm	480 mm

Test results

1. Influence of the front axle suspension to drawing capacity (or to the drawbar pull)

As an example the Figure 1. shows the changes of drawbar pull in rear wheel drive operation mode on arable land and in the function of wheel slip. We can see that the values of drawbar pull was higher with 2,4-4,2 % in on position of the front axle suspension than off position of the front axle suspension.

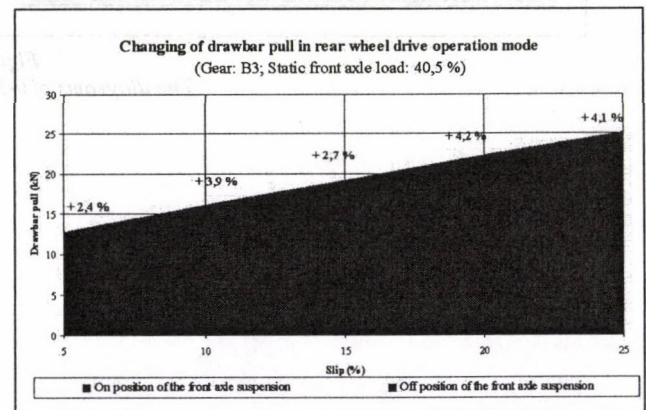

Figure 1

The next figure shows the same adjustment parameters in four wheel drive operation mode. We can see that the values of drawbar pull was higher with 7,0-9,2 % in on position of the front axle suspension than off position of the front axle suspension.

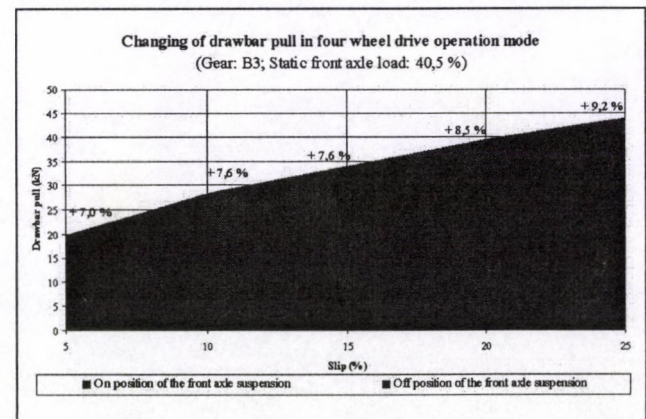

Figure 2

2. Influence of the front axle suspension to the maximum drawing power

As an example the Figure 3. shows the changes of maximum drawbar power in rear wheel drive operation mode on arable land and in the function of static front axle load. We can see that the values of drawbar power was higher with 2,5-5,2 % in on position of the front axle suspension than off position of the front axle suspension. Figure 4. shows the same adjustment parameters in four wheel drive operation mode.

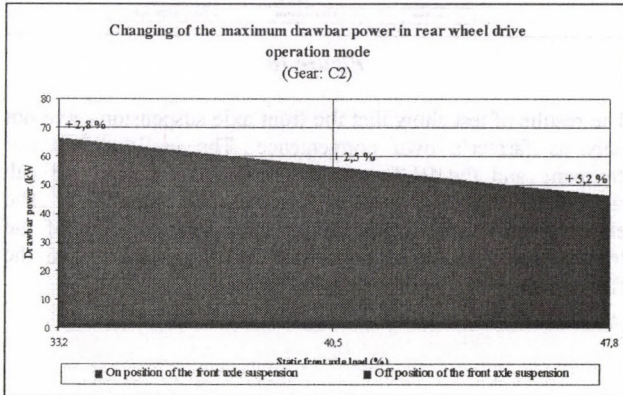

Figure 3

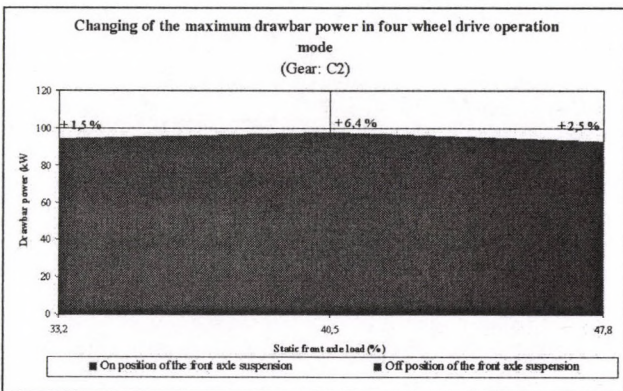

Figure 4

3. Influence of the front axle suspension to the fuel consumption

On the next figures we can see changing of fuel consumption at the maximum drawbar power in rear wheel drive and in function of static front axle load. We can see that the values of fuel consumption was lower with 3,5-5,6 % in on position of the front axle suspension than off position of the front axle suspension.

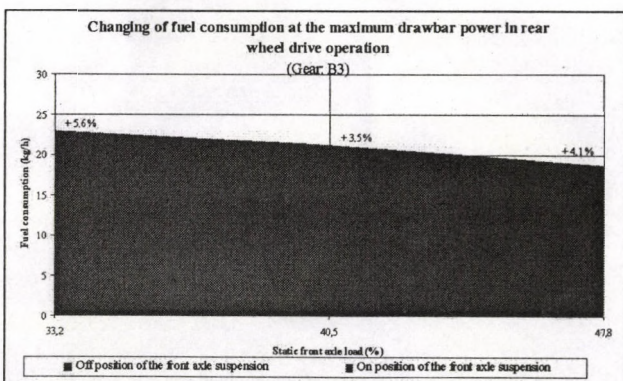

Figure 5

We can see that the values of fuel consumption was lower with 2,5-4,1 % in on position of the front axle suspension in four wheel drive operation mode.

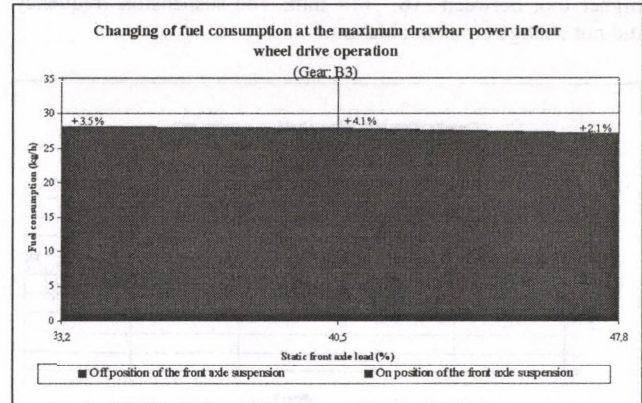

Figure 6

4. Influence of the front axle suspension to the amplitude of vibration

As an example this figures show the change of amplitude in rear wheel drive operation mode on arable land and in the function of time. The selected settings parameters: gear B3, travelling speed 7,2 km/h, the wheel slip 20 % and the static front axle load was 33,2 %. On the Figure 7. we can see vertical dislocations on the tractor frame and left and right side of front axle. The value of amplitude changed between -9...+8 mm in on position of the front axle suspension. The suspension frequency did not change considerable. The next figure shows the same adjustment parameters in off position of the front axle suspension. You can see that the values of amplitude higher, between -17...+18 mm.

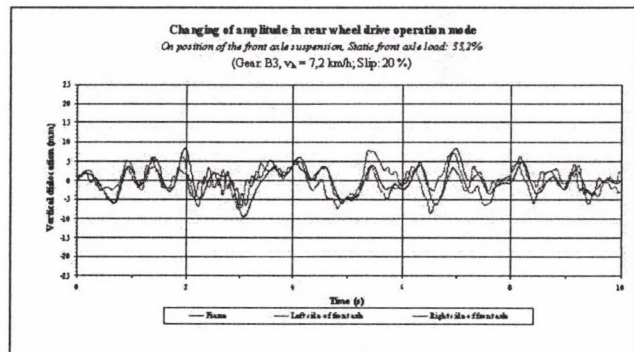

Figure 7

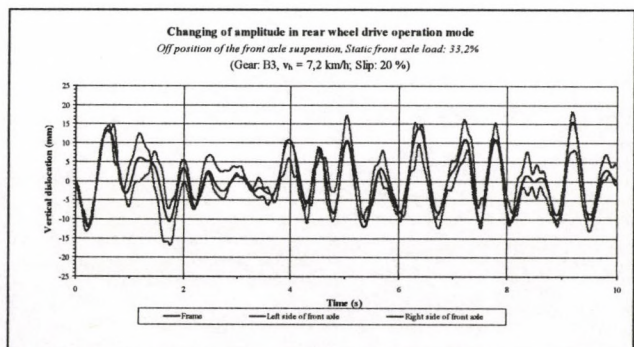

Figure 8

On the Figure 9. shows the change of amplitude in four wheel drive operation mode. The value of amplitude changed between -12...+9 mm in on position of the front axle suspension. The

suspension frequency did not change considerable. The Figure 10. shows the same adjustment parameters in off position of the front axle suspension. You can see that the values of amplitude higher too, between -16...+17 mm. The suspension frequency did not change considerable too.

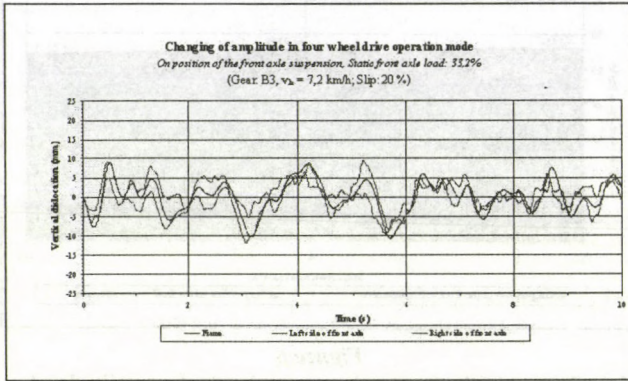

Figure 9

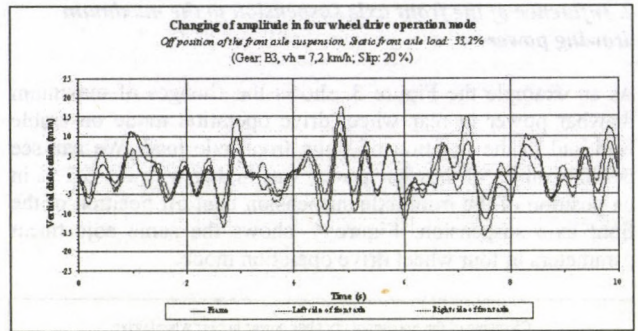

Figure 10

The results of test show that the front axle suspension serve not only as farmer's own convenience. The earlier years our company and the BLT together measured the seat and cab suspension. These parameters show similar our results. The effect on position of front axle suspension increased of the traction performance (drawbar pull, drawing power) and the fuel consumption decreased.

... of the front axle suspension... the results of test show that the front axle suspension serve not only as farmer's own convenience. The earlier years our company and the BLT together measured the seat and cab suspension. These parameters show similar our results. The effect on position of front axle suspension increased of the traction performance (drawbar pull, drawing power) and the fuel consumption decreased.



Figure 7

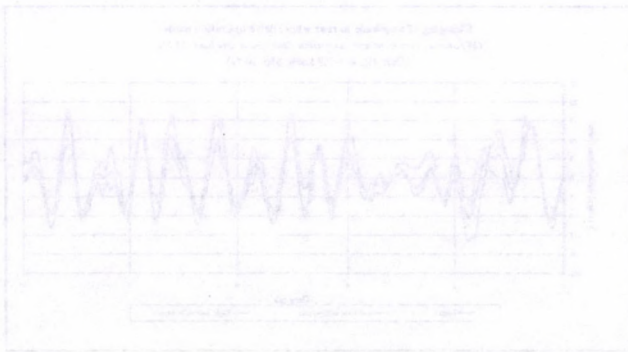

Figure 8

... of the front axle suspension... the results of test show that the front axle suspension serve not only as farmer's own convenience. The earlier years our company and the BLT together measured the seat and cab suspension. These parameters show similar our results. The effect on position of front axle suspension increased of the traction performance (drawbar pull, drawing power) and the fuel consumption decreased.



Figure 9

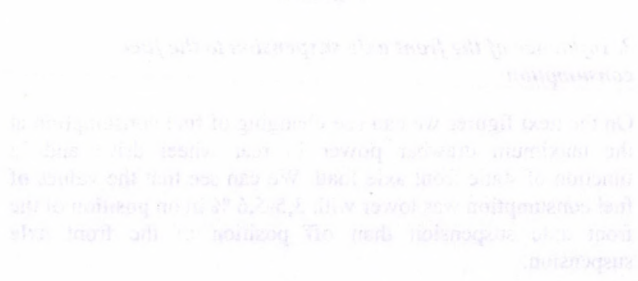

Figure 10

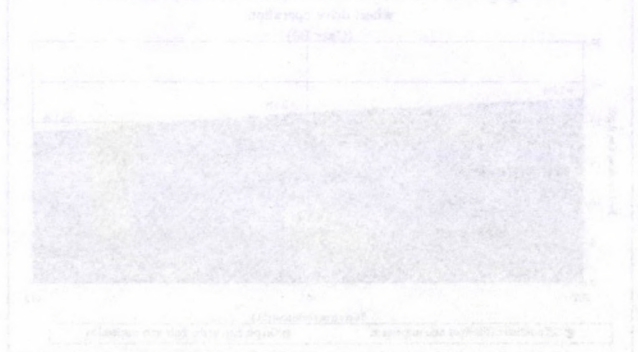

Figure 11

PLANT-PERCEIVING SPRAYING MACHINE IN ORCHARDS

Gy. Dimitrievits – Z. Gulyás – L. Kovács – L. Magó
Hungarian Institute of Agricultural Engineering, Gödöllő

On horticultural plantations, significant losses, of 15-40%, sometimes of 80-90% may arise during the spraying procedures used nowadays. All these lead to substantial material and environmental losses.

The main cause of these losses is that the wall of leaves is usually broken, not contiguous on the orchards sprayed on. Owing to the peculiarities of various forms of planting, the different stages of development of the plants, the gaps in the rows of trees or stumps, a great deal of the disinfectant spray cannot get to the surface of destination during continuous spraying, the majority gets to the soil, the rest of it is swept away or evaporated.

To solve the problem, a system has been developed. It operates with infrared sensors and mounted on to spraying machine KERTITOX BORA 2000 type. The equipment is made up of infrared sensors placed on consoles, a central unit, magnetic valves fixed on to spraying nozzles and wheel-signal devices. The 3-3 or 6-6 sensors, placed on each side on two adjustable consoles at various heights, are to perceive plants. The distance between the sensors and the foliage may be altered by moving the consoles. Shadowing plates protect the infrared sensors from the foliage and the disinfectant spray. If the sensors do not perceive foliage at the given height and side, the central unit will give an order to switch off spraying in that place. This order will be executed by minute valves installed in front of the spraying nozzles. As the sensors are fixed in the front-part of the machine and the spraying device at the back, perception and switching had to be synchronised. Thus signal devices have been fixed on to the running-wheel of the spraying machine. Running speed may be clocked with these devices. After entering the distance between the plant-sensors and the spraying device, the central unit continuously determines the necessary measure of the retardation of switches in the function of running speed and controls cut-off valves accordingly. The machine sprays in compliance with the position and height of the foliage.

The structure of ultrasonic plant-perceiving equipment is similar to the one equipped with infrared sensors. The difference lies in the system and operational characteristics of sensors and the structure of the central unit. The 2 sensors at each side are fixed in position in the front-part of the machine. The spraying nozzles are switched in 2 phases at each side in accordance with the number of sensors. During testing, central units of Bravo 134 type of also ARAG make were used. 4 sensors may be fixed to the device. During testing, the trees to be sprayed on were perceived at two heights (120 cm, 210 cm). A control block made up of 4 electrically-operated valves to switch the spraying arches as well as a sensor equipped with reed relay to determine the running speed may be jointed to the central unit. A pressure-LD-transmitter has also been installed in the control block.

The following numerical values, most of which will be stored, may be indicated on the display of the central unit:

- running speed of the machine,
- quantity of the disinfectant spray vaporised,
- the dimension of the area sprayed on,
- distance taken,
- number of trees sprayed on,
- liquid level of the tank,
- working pressure.

The equipment operating with the ultrasonic plant-perceiving system involved in the tests examines the foliage at two heights and controls the operation of the spraying nozzles in groups, side by side.

In vineyards and orchards, on the spraying machines equipped with infrared and ultrasonic sensors, laboratory, functional, working quality and permanent operational tests have been conducted. Besides the machines have been tested under conditions resembling to operation.

During the laboratory and functional tests, it was established that the distance of perception was 1 m in case of infrared equipment, while the ultrasonic system operated reliably up to 5 m. The exactness of perceiving foliage is within 5 cm in case of both system in the speed domain of 4 to 10 km/h. The maximum perceptual width of infrared sensors was 10 cm. It was 50 cm in case of ultrasonic ones.

In order to determine the working quality characteristics of the machines equipped with infrared sensors, tests have been carried out in the respect of coverage in apple- and cherry orchards and in vineyards, with and without plant-perceiving devices. Please find the result of the coverage test carried out in an apple-orchard in Table 1.

Based on the data, it may be established that there had not been any noticeable differences between the quality of spraying with the two kinds of technology. The end values of coverage were nearly the same in the different plant zones, so were the average of that. Not any significant differences have been observed in the quantity of the disinfectant spray being deposited on the adaxial and abaxial surface of the leaves. On the evidence of the detailed analyses of the data, it was established as well that the coverage had also been nearly the same on the edge of the foliage, where the plant-perceiving device had stopped spraying, in case of both technologies. The device switched off spraying with the exactitude of 0 to 4 cm. Thus the foliage at the edge of the crown of the trees, that is otherwise of a smaller surface, obtains enough disinfectant spray.

Measuring have been repeated with the device equipped with ultrasonic sensors in apple-orchards. Not any noticeable differences have been observed between the quality of spraying with the two kinds of technology nor in this case either.

In order to quantify the saving of disinfectant spray by using plant-perceiving devices, tests have been carried out under conditions resembling to operation in apple-, plum-, cherry- and sour cherry-orchards.

In the course of the tests, spraying has been carried out in the respective orchards with plant-perceiving devices being switched on and off, in the same position. The disinfectant spray used and the saving resulting from the use of the plant-perceiving device were quantified in every case.

In order to quantify the saving of disinfectant spray by using infrared plant-perceiving devices, tests have been carried out under conditions resembling to operation in apple- and cherry-orchards and vineyards. Spraying has been carried out with plant-perceiving devices being switched on and off, on the same strips, in the same position. The disinfectant spray used and the saving resulting from the use of the plant-perceiving device were quantified in every case. See the numerical values measured in the respective orchards in Fig. 1.

In order to quantify the saving of disinfectant spray by using ultrasonic plant-perceiving devices, tests have been carried out under conditions resembling to operation in apple-, plum-, cherry- and sour cherry-orchards.

In the respective orchards, in the direction of spraying, the percentage of the foliage and the whole surface sprayed on are as follows:

apple	40%
plum	32.5%
cherry	38%
sour cherry	40%

According to this data, a considerable saving of disinfectant spray has been expected. In the course of the tests, spraying has been carried out in the respective orchards with plant-perceiving

devices being switched on and off, in the same position. The disinfectant spray used and the saving resulting from the use of the plant-perceiving device were quantified in every case. Results can be seen in Fig. 2.

From the data obtained as the result of the tests, it is evident that a saving of disinfectant spray of 50.9% to 75.9% was achieved by using ultrasonic plant-perceiving devices. The savings achieved in the apple- and cherry-orchards were more than the numerical value calculated from the surfaces. There have been basically two reasons for that. In these orchards, there was a lack of trees of 2 to 5%. It has been resulted in further sections done with the spraying mechanism being switched off. Furthermore, the foliage was not homogenous either.

As the plant-perceiving device perceived foliage at more than one height and switched on the spraying nozzles accordingly, it may have occurred that the upper or the lower zone has been left out of spraying owing to the thin foliage. Consequently, these factors have resulted in further saving as compared to the theoretically estimated value.

On the evidence of the tests, to sum up, it may be established that both spraying machines operating with infrared plant-sensors and the ones equipped with ultrasonic sensors are suitable for spraying orchards saving chemicals and taking care of the environment. Both systems are suitable for controlling and operating spraying in accordance with the continuity and position of the foliage in vineyards and orchards. Although there are some differences in the range of sensors of various structure and the width of perception thereof, both systems are

suitable for perceiving foliage with sufficient exactitude (within 5 cm). Short-range infrared sensors may be more expedient in vineyards while it is better to use long-range ultrasonic ones in orchards. Based on the signals received, the central units used have properly controlled spraying, taking running speed into consideration. The operating valves have provided for the spraying nozzles being closed or opened randomly. The sensors have proved sufficiently reliable.

The quality of spraying carried out with plant-perceiving equipment proved to be equal to the quality of work done without using the equipment.

The rate of the saving of disinfectant spray largely depends on the density of the foliage of trees in the direction of spraying (how contiguous the foliage is).

In newly planted orchards where the foliage of plants does not touch each other, or in case of the first spraying in spring, a 50 to 75% saving may be achieved. In case of spraying contiguous foliage, a saving of 5 to 20% may be calculated.

The rate of saving depends on the number of sensors as well. If a machine is equipped with spraying heads with axial ventilators, it may be reasonable to use no more than 3 pairs of sensors. It may be expedient to use 1 or 2 pairs of sensors in case of new plantations, while 3 pairs in case of older ones with complete foliage.

It may promote the spreading of plant-perceiving devices that they can be mounted on not only to new machines but old ones as well. Beside the economic advantages, the application of plant-perceiving equipment will result in the reduction of chemicals that damage the environment.

Table 1 Coverage in apple orchards

level of height	level of depth	side of leave	coverage (%)			
			without plant-sensors		without plant-sensors	
			end values	averageátlaga	end values	averageátlaga
lower	I.	adaxial surface	42-20	29	44-22	31
		abaxial surface	28-13	17	27-13	15
	II.	adaxial surface	33-17	24	30-15	23
		abaxial surface	22-11	14	25-14	15
	III.	adaxial surface	30-13	21	26-16	20
		abaxial surface	17-6	12	18-9	12
central	I.	adaxial surface	45-19	30	51-21	28
		abaxial surface	28-12	19	31-10	18
	II.	adaxial surface	36-17	23	32-14	19
		abaxial surface	20-7	10	17-6	9
	III.	adaxial surface	26-12	17	26-13	18
		abaxial surface	15-6	9	15-7	10
upper	I.	adaxial surface	37-17	25	40-19	26
		abaxial surface	27-11	17	23-10	15
	II.	adaxial surface	30-12	18	32-14	20
		abaxial surface	21-8	11	16-7	10
	III.	adaxial surface	23-14	17	25-12	17
		abaxial surface	12-5	7	13-5	8

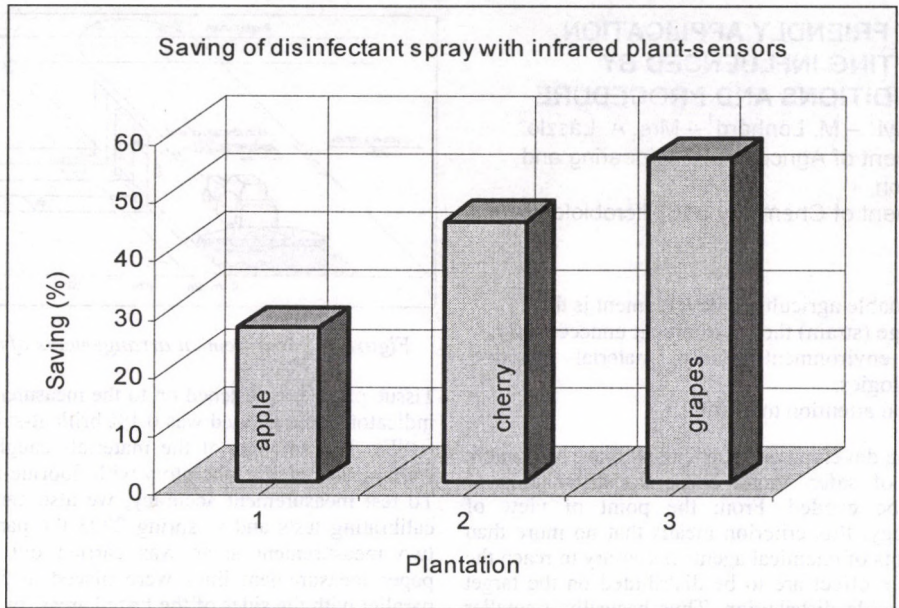

Figure 1
Saving of disinfectant spray in case of infrared plant-sensors on various plantations

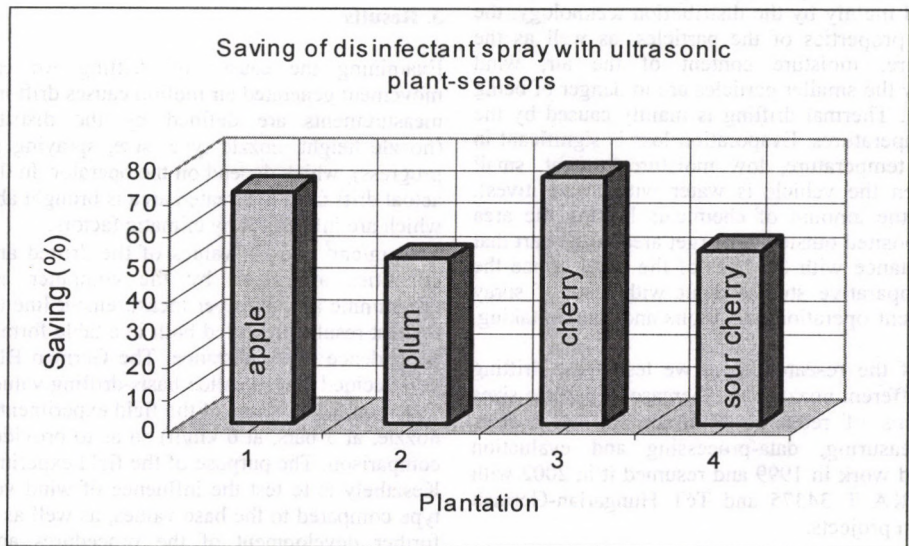

Figure 2
Saving of disinfectant spray in case of ultrasonic plant-sensors in orchards



Figure 3 Material deposition expressed in % of all the material deposited (R100K - 2 bar)

Material and method
In the field experiment we established the lines of the testing mass to find in case of wind direction changes, the direct data should still arrive in the neighborhood area within a accepted limit. During the tests the following weather data were continuously registered in the tested area:

- direction of the wind
- wind velocity
- temperature of the air
- the relative content of the air
- clouds

A maximum distance of 2000 was chosen in the direction of the wind from its main trends. It was the same as the direction of the measurement lines perpendicular to the direction of movement. The average speed of the wind during the measurements was 2-3 m/s in case of higher number 2-3 and its maximum changes were not to exceed 50% max. Operation speed was decided to be 40-80 km/h and the test was carried out with different wind and different size Teflon nozzle. To measure the floating particles of insect drifting we used plastic straws with diameter of 2 mm put up vertically up to the height of 1 meter. The amounts deposited on the soil were measured with 7 measurement lines placed at a distance of 2-3 m from one another, at the length of 30 meters (figure 1).

ENVIRONMENT FRIENDLY APPLICATION, TESTS OF DRIFTING INFLUENCED BY WEATHER CONDITIONS AND PROCEDURE

A. László¹ – B. Pályi¹ – M. Lönhárd¹ – Mrs. A. László²

¹VU GFA Department of Agricultural Engineering and Farm Mechanisation

²VU GFA Department of Chemistry and Microbiology

1. Introduction

A criterion of sustainable agricultural development is that

- it should not damage (strain) the environment unnecessarily,
- it should apply environment-friendly, material effective, economical technologies,
- it should pay special attention to quality.

When it comes to the development of chemical plant protection, the research tasks of safer, target conscious distribution of chemicals cannot be evaded. From the point of view of application technology, this criterion means that no more than the minimum amounts of chemical agents necessary to reach the biologically desirable effect are to be distributed on the target area in the best possible distribution. Thus basically a smaller amount of chemicals needs to be used and less substance gets to places where it might have harmful consequences.

Losses (winds, thermals, evaporation, deposition in non-target areas are influenced mainly by the distribution technology, the sizes and physical properties of the particles, as well as the climate (temperature, moisture content of the air, wind velocity). Especially the smaller particles are in danger of being drifted by the wind. Thermal drifting is mainly caused by the dramatic fall of temperatures. Evaporation loss is significant in cases of high air temperature, low moisture content, small particle sizes, (when the vehicle is water without additives). Wind drift means the amount of chemicals leaving the area treated that gets deposited outside the target area or the part that covers a longer distance with the help of the wind. Since the 1980's several comparative studies dealt with tests of spray drifting, with different operation conditions and sample taking. [1, 2].

Within the tasks of the research topic we tested the drifting characteristics of different nozzles; the increase of particle sizes as a possible means of reducing drifting, and we further developed the measuring, data-processing and evaluation methods. We started work in 1999 and resumed it in 2002 with the support of OTKA T 34375 and TÉT Hungarian-German research cooperation projects.

2. Material and method

In the field experiment we established the sizes of the testing areas so that in cases of wind-direction changes, the direct drifts should still arrive in the measurement area within a accepted limit. During the tests the following weather data were continuously registered in the tested area:

- direction of the wind
- wind velocity
- temperature of the air
- the moisture content of the air
- clouds

A maximum difference of $\pm 30\%$ was allowed in the direction of the wind from its main trends. It was the same as the direction of the measurement lines perpendicular to the direction of movement. The average speed of the wind during the measurements was 2-3 (in case of injector nozzles 2-5) m/s, its maximum changes were not to exceed $\pm 0,5$ m/s. Operation speed was decided to be 4-6-8-12 km/h and the tests were carried out with different type and different size TeeJet nozzles. To measure the floating particles of direct drifting we used plastic strings with diameters of 2 mm put up vertically up to the height of 4 metres. The amounts deposited on the soil were measured with 5 measurement lines placed at a distance of 2-3 m from one-another, at the length of 30 metres. (Figure 1)

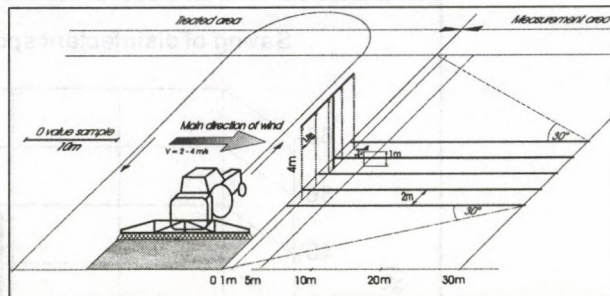

Figure 1 Measurement arrangements of field drifting tests

Tissue paper was fastened on to the measurement lines while the indicator liquid applied was 0.1% brilliant-sulpho-flavin solution (BSF). The amounts of the materials caught with either traps were measured in a laboratory with fluorine-metric methods.

To test measurement accuracy, we also carried out laboratory calibrating tests and in spring 2003 the parallel application of two measurement areas was carried out. Continuous tissue paper measurement lines were placed at 5-10-20-30-50 m in parallel with the sides of the tested areas; on these measurement lines Petri dishes were placed (5 x 10 of them). Measurements were taken in 3 repetitions.

3. Results

Examining the causes of drifting we can conclude that movement generated air motion causes drift in the first place. Its measurements are defined by the distribution parameters (nozzle height, nozzle type, size, spraying pressure, speed of progress), which depend on the operator. In the second stage, an actual drift from the treated area is brought about by side winds, which are influenced by climatic factors.

The $\mu\text{g}/\text{cm}^2$ and %- values of the drifted and deposited agent quantities are given by the computer assisted evaluation programme as values per measurement line and as the mean of the test results presented both in a table form and graphically in dependence of the distance. The German BBA partner institution decided that so called basis-drifting values should be established on the database of the field experiments. (11003 type. per nozzle, at 3 bars, at 6 km/h) so as to provide a unified base of comparison. The purpose of the field experiments carried out in Keszthely is to test the influence of wind velocity, and nozzle type compared to the base values, as well as the evaluation and further development of the procedures and equipment that might decrease drifting. Based on the test results it can be established that depending on the distance, the amount of the material drifted and deposited on the ground (expressed in % of all the distributed material) changes according to a negative index power function. Thus on a twofold logarithmical scale correlations can be shown with approximately paralleled straight lines (Figure 2). In case of bigger distances, the measurement points careered off the straight lines mainly upwards, due to the thermals (greater decrease of temperatures).

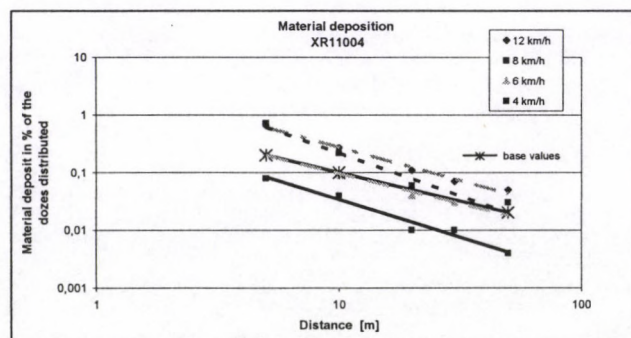

Figure 2 Material deposition expressed in % of all the material distributed (XR 11004 - 3 bar)

At 5 meters, on the surface of the two catcher areas, (tissue paper and Petri dishes) we measured approximately the same deposited amounts, however above this, the paper showed higher values. Its result is that with tissue paper, we got straight lines with direction tangent different from the base line (that is, the quantity of the material deposited decreased to a smaller extent with the distance).

The reason is the unreliability of the 0 values of the tissue paper, its quality differences, as it might contain chemicals acting similarly to the tested materials, which might increase, distort the smaller values. Under ideal conditions, in the laboratory testing of measurement accuracy, we found that the Petri-dish tests showed smaller error deviation.

Open field drift measurements are a labour consuming activity, they are difficult to reproduce that is why at the BBA a new measurement procedure was developed to establish the drifting potential of arable field sprayers, during which plant protection nozzle heads are examined in an air-duct under certain conditions, with laser optic procedures. In order to be able to take measurements in an air-duct a Phase-Doppler-Particle-Analyser and a special laser light-segmentation has to be used. This measurement method makes it possible to establish the volume and the point of gravity of the drifted cloud. These two parameters together give a drifting potential marker, the so called DIX-index. (Drift Potential Index - DIX). With its help, the drifting potential of different nozzles can be easily classified similarly to the well-known BCPC-schemes, which is used to define drop spectra.

The test results of the arable field drifting have proved that the DIX-values received from air-ducts and the chemical deposit values received in the arable field tests are in a correlation in a wide range of application conditions ($R^2=0.83$).

One of the methods of agent economical distribution is the decrease of drop sizes, an even distribution of smaller drops, which in turn significantly increases the risk of drifting, especially if the proportion of drops smaller than $100\mu\text{m}$ is higher. Its extents have been confirmed by the test results of the floating particles with CDA spraying heads. (Figure 3.) compared to the characteristics of a 11002-slot nozzle. The other means of economising with chemicals is to decrease losses.

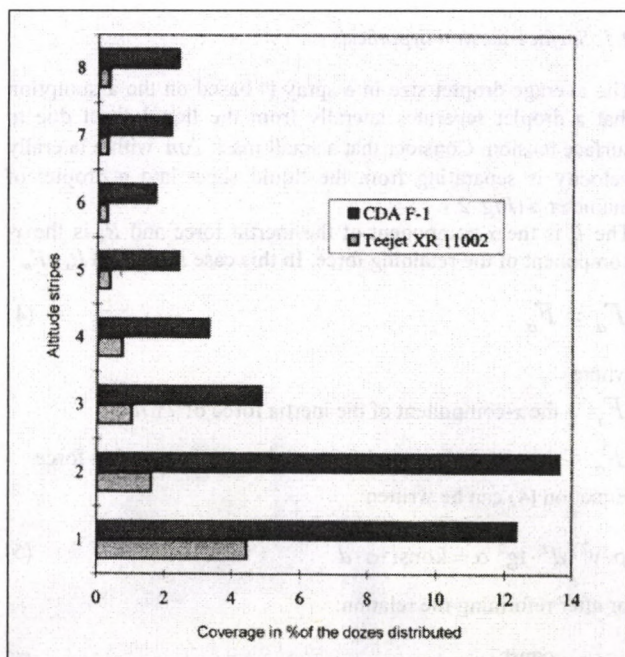

Figure 3 Material deposit with CDA spraying heads (floating particles)

We might for instance apply air-bag assistance with the protection of arable lands, closed-system re-circulation equipment with vineyards and orchards and lubricating machines with weed killing, respectively.

A simple and efficient method of decreasing drifting losses is the increasing of drop sizes, which may be achieved by the

application of materials increasing viscosity or the application of new type injector nozzles. (AD - Anti-drift or ID - Injector). It will make it possible to spray chemicals even if there is a higher wind speed without significant losses. In comparison with the so called base drifting values defined with traditional distribution, anti-drift or drift reducing gadgets significantly decrease drifting. [3]. The arable field sprayers equipped with injector nozzles, drifting may decrease by 50-75% if within 20 meters from the side of the field the farmer works at a lower speed and a lower pressure. (max. 5 km/h, max. 3.0 bar).

In Germany an official register of drift reducing sprayers was set up. Figure 3 shows the 50-75-90% classification boundaries of arable land sprayers and sprayer heads as compared to the drifting values calibrated by the BBA.

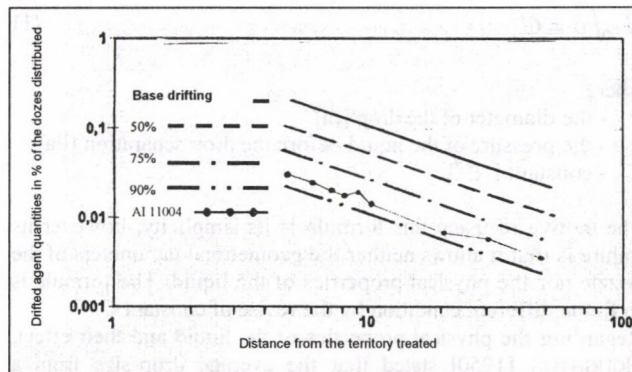

Figure 4 The classification of drift-reducing sprayers

We included the decreasing effect of the AI 11004 injector nozzle used in the Keszthely experiments. The future introduction and application of the system is professionally justified in Hungary as well.

4. Result and recommendations

- Arable land chemical drifting is mainly caused by distribution technology factors (drop spectra, spraying head type, spraying head sizes, distributed quantities, spraying pressures and heights, speed of application) and climatic factors (wind velocity, and direction, air temperatures, relative air moisture, clouds. Bigger VMD drop sizes and lower application speed decreases drifting.
- From among the meteorological factors, it is wind velocity that most influences drifting, brings about an increase of drifting.
- With wind velocity values exceeding 3 m/s it is necessary to apply new-type anti-drift spraying head constructions (AD, AI, ID). These allowed us to measure still acceptable drift values even with winds stronger than 5 m/s.
- The effect of motion winds bringing about the risk of drifting may well be simulated in air-ducts. There is a linear regressive correlation between the DIX (drifting potential index) calculated this way and the drifting values of actual operation.
- On a two-fold logarithmical scale, the amount of chemicals drifted in dependence of the distance may be illustrated with approximately straight lines in parallel. Compared to the so called base drifting values, the tested gadgets, spraying heads can be assessed and classified, thus their applicability conditions can be officially regulated.

5. References

- [1] Ganzelmeier, H. (1986): Abdrift beim Einsatz von Sprüh- und Staubegeräten im Obst- und Ackerbau. Grundl. Landtechnik. Bd. 6., Nr. 6., 174-179.p.
- [2] Rudolph, R. (1995): Abdrift verschiedener Düsen. Landtechnik, Nr. 2., 66-67.p.
- [3] Ganzelmeier, H. (2000): Drift studies and drift reducing sprayers - a german approach ASAE Meeting Presentation No. 001024.

FORCE-BASED ATOMIZATION THEORIES FOR SPRAY NOZZLES

I. Sztachó-Pekáry
College of Kecskemét

1. Introduction

FRENCH [1942] and AKENSON [1952] reported that the average drop-size produced by a nozzle varies nearly as the inverse square-root of the pressure p . There have been developed some equations relating drop size d and a lot of other parameters. There is the well known empirical formula:

$$d \cdot \sqrt{p} = C \quad (1)$$

where

d - the diameter of the drop [m]
 p - the pressure of the liquid before the drop separation [Pa]
 C - constant [$N^{0.5}$]

The motive of using this formula is its simplicity; however its failure is that it allows neither the geometrical parameters of the nozzle nor the physical properties of the liquid. The formula is to fit the different condition by the revise of constant C .

Regarding the physical properties of the liquid and their effect, HOUGHTON [1950] stated that the average drop-size from a given nozzle is decreasing if both the surface tension σ or density ρ is reduced, and that it is not greatly affected by viscosity μ of water.

LANE [1951] attempts to explain atomization in an air blast by means of a simplified assumption relating the dynamic drag to the surface tension. He comes up with an expression in the following form (surface tension is included in the constant):

$$(v_{air} - v_{spray})^2 = \frac{K}{d} \quad (2)$$

where

v_{air} - the velocity of air [$m\ s^{-1}$]
 v_{spray} - the velocity of liquid [$m\ s^{-1}$]
 K - constant [$m^3\ s^{-2}$]

This relation resembles the relation of LITTAYE [1943], where ρ is considered constant and relative velocity is used in that relation.

HINZE [1955] says that the forces controlling deformation and breakup make up two nondimensional groups: the *WEBER-group* and a *viscosity-group*. Breakup occurs when the *WEBER-number* $W = v\sqrt{\sigma/\rho \cdot p}$ exceeds a critical value. FASER [1958] gives the following relation describing droplet surface mead-diameter from swirl spray nozzles:

$$d \approx p^{-0.453} \cdot q^{0.209} \cdot v^{0.215} \quad (3)$$

where

q - the rate of discharge [$m^3\ s^{-1}$]
 v - the kinematical viscosity of the liquid [$m^2\ s^{-1}$]

But the least to be said about this formula is that it has inconsistent dimensions and is based on little or no theoretical background. With the use of *WEBER-number* it is to write an empirical relation for the predicted droplet size too [LÁSZLÓ in SITKEI ed. 1997].

VÖRÖS [1935] measures droplet size from hollow-cone nozzles by means of receiving their traces on calibrated blotting paper. Resulting spray-cone angles varies according to variations in the swirl-chamber depth. Similar measurements have been

made by EL-AWADY – AFIFI [1974] by means of receiving droplets in an oil bath. LÁSZLÓ [1979] analyzes the effect of internal and external forces on the droplets and has got theoretical and empirical conclusions.

It is seen from the above review that there is no unified theory to tie up the drop size to affecting parameters, including pressure, spray-cone angle, and liquid properties: surface tension, viscosity, and density. The sought theory should satisfy the following conditions:

- correct dimensions;
- sound theoretical background;
- generality in the sense that includes all pertinent factors;
- applicability to existing data.

Application of the atomization theory includes prediction and control of drop size to meet optimum requirements. Equipment designer can take care of variations in nozzle geo-metry as well as spraying pressure and liquid properties. Operators can take care of pressure variation as well as liquid properties in some cases. Spraying material manufacturers supply materials that contribute to drop size control through different physical properties: viscosity, surface tension and density. Lately, products available include viscosity modifiers. Surface tension modifiers include stickers, detergents, and wetting agents. But no appreciable density modifiers are known.

2. Theories based on force balance hypothesis

The theoretical process of atomization of liquid sheet assumes that the droplet inertia has to exceed surface tension in order to separate. It is further assumed that droplets and sheet body move with the same longitudinal velocity, thus atomization is caused by the lateral component of the inertia only, as has been seen on the *Fig. 1*. by GERENCSEI [1981].

The next two theories show that the liquid atomizes by forming a sheet which disrupts into liquid ligaments and further into droplets.

2.1. Surface-tension hypothesis

The average droplet size in a spray is based on the assumption that a droplet separates laterally from the liquid sheet due to surface tension. Consider that a small mass Δm with a laterally velocity is separating from the liquid sheet into a droplet of diameter d (*Fig. 2*).

The I_x is the x -component of the inertia force and R_x is the x -component of the retaining force. In this case $I_x = F_a$ and $R_x = F_\sigma$

$$F_a = F_\sigma \quad (4)$$

where

F_a - the x -component of the inertia force of Δm

F_σ - the x -component of the retaining surface tension force

Equation (4) can be written:

$$\rho \cdot v^2 \cdot d^2 \cdot \text{tg}^2 \alpha = \text{konst} \cdot \sigma \cdot d \quad (5)$$

or after reforming the relation:

$$\text{tg}^2 \alpha = \frac{\text{const}}{W} \quad (6)$$

where

ρ - the liquid's density [$kg\ m^{-3}$]

v - the x -component of the velocity of Δm [$m\ s^{-1}$]

α - half spray angle [rad]

σ - the surface tension [$N\ m^{-1}$]

W - the *WEBER-number* []

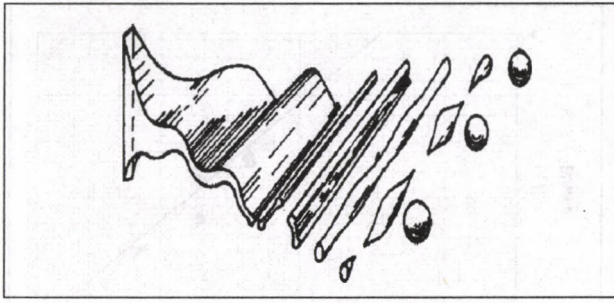

Figure 1 Successive stage in an idealized breakup of liquid sheet [GERENCŠÉR, 1981]

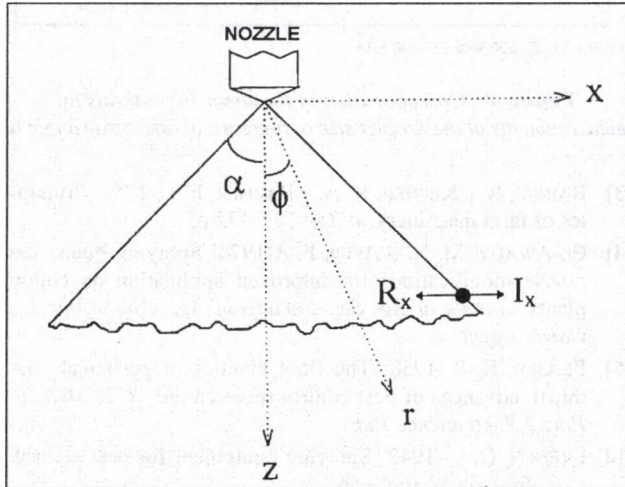

Figure 2 Separation of a droplet in laterally direction

Except for the trigonometrical factor, equation (6) conforms with the relations (1) and (2).

Given that v is nearly proportional to the square root of pressure ([AKESSON 1952], [FRENCH 1942]) equation (5) takes the following form:

$$d \cdot p \cdot \text{tg}^2 \alpha = \text{konst} \cdot \sigma \quad (7)$$

Equation (7) can be written:

$$d = \text{konst} \frac{\sigma}{p \cdot \text{tg}^2 \alpha} \quad (8)$$

This equation suggests that the mean drop-size varies inversely with the pressure, when the effect of other factors is isolated, and not with its square root which contradicts experimental results of AKESSON [1952], FRENCH [1942], and YOUNIS [1969].

2.2. Shear hypothesis

The shear hypothesis is based on the assumption that the separation of drops is caused by shear with the stagnant boundary. Thus the droplet inertia has to overcome the viscous shear induced at a nearly lateral plane in order to cause separation (Fig. 2.).

Similarly to the pervious case I_x is the x -component of the inertia force and R_x is the x -component of the retaining force. In this case $I_x = F_a$ and $R_x = F_\mu$.

$$F_a = F_\mu \quad (9)$$

where

$$F_\mu \text{ - the force effect of the viscosity [N]}$$

Equation (9) can be written:

$$\rho \cdot d^2 \cdot v^2 \cdot \text{tg}^2 \alpha = \text{const} \cdot \mu \cdot d \cdot v \cdot \text{tg} \alpha \quad (10)$$

where

μ - the cinematic viscosity [$\text{m}^2 \text{s}^{-1}$]

It can be safely assumed that the velocity v is proportional to the square root of pressure ($v \approx \sqrt{p/\rho}$ [BAINER et al., 1955]).

Equation (10) takes the following form when this assumption and proper transposition are made:

$$d \cdot \sqrt{\rho \cdot p} \cdot \text{tg} \alpha = \text{const} \cdot v \quad (11)$$

or after reforming the equation:

$$d = \text{const} \cdot \frac{v}{\sqrt{\rho \cdot p} \cdot \text{tg} \alpha} \quad (12)$$

In this equation the mean drop-size varies inversely with the square root of the pressure, when the effect of other factors is isolated.

3. Verification

3.1. Surface-tension hypothesis

Fig. 3 shows the variation of the parameter X with variations in pressure p and half spray angle α from the data of EL-AWADY - AFIFI, [1974] and YOUNIS [1969]. Data are plotted according the following modification of the form of equation (8):

$$X = \frac{p \cdot \text{tg}^2 \alpha}{\sigma}, \text{ therefore the equation becomes: } d = \frac{C_1}{X}$$

The relation gave particularly good agreement at low values of pressure group X ($R^2=0.8390$). The average value of C_1 was 530. It seems, that at high pressure, when the liquid-cone contracts, the common effect of the pressure p and half angle α very similar to the effect of the square root of the pressure \sqrt{p} .

At low values of pressure the droplet-sizes are smaller than expected from theory.

3.2. Shear hypothesis

Fig. 4 shows the variation of the parameter X with variations in pressure p and half spray angle α from the data of EL-AWADY - AFIFI, [1974] and YOUNIS [1969]. Data are plotted according the following modification of the form of equation (12):

$$X = \frac{\sqrt{\rho \cdot p} \cdot \text{tg} \alpha}{\mu}, \text{ therefore the equation becomes: } d = \frac{C_2}{X}$$

The relation gave less good agreement than at the first case ($R^2=0.6686$), but it fitted better at high values of pressure group X . The effects of the pressure p and cone half angle α had less effect on this hypothesis than with the surface tension hypothesis. The average value of C_2 was 2100.

4. Summary and conclusions

There were worked out two hypotheses for atomization:

- the droplets separate laterally from liquid sheet or ligament against surface tension, and
- the droplets separate laterally against viscous shear.

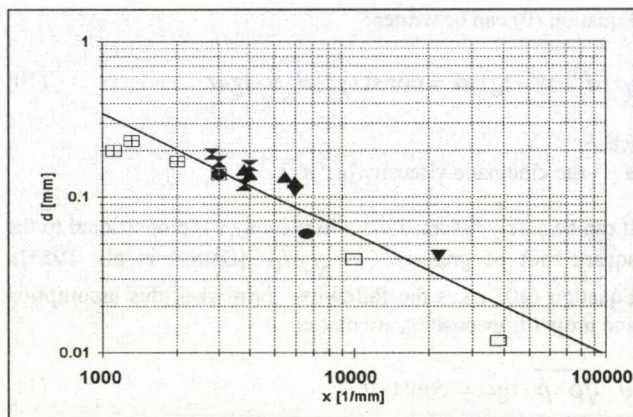

□ 1 MPa ▼ 750 kPa ● 500 kPa ▲ 400 kPa × 300 kPa ⊞ 200 kPa

Figure 3 Corroboration of the tension hypothesis by measurements of droplet size d , pressure p , and spray angle α

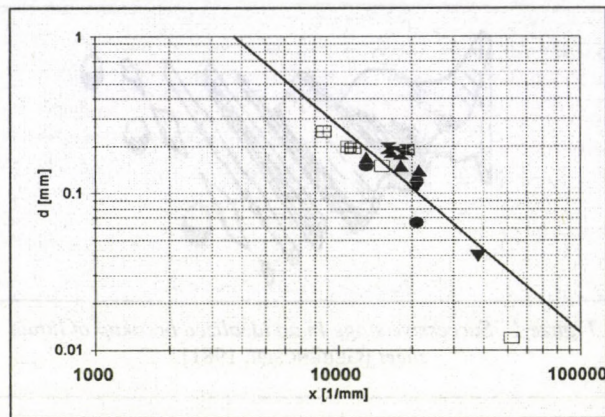

Figure 4 Corroboration of the shear hypothesis by measurements of the droplet size d , pressure p , and spray angle α

The well known tension and shear hypothesis familiar to the workers in the field of spraying respectively lead to the following formulas:

$$C_1 = \frac{d \cdot p}{\sigma} \operatorname{tg}^2 \alpha; \quad C_2 = \frac{d \cdot \sqrt{\rho \cdot p}}{\mu} \operatorname{tg} \alpha$$

During atomization, a liquid is exposed to shear and tension forces. Atomization follows the mechanism meeting less resistance, thus allowing droplets of smaller size and inertia to separate. At critical limit, i. e. the shear and tension mechanism are equally effective; the drop size is the same whether computed by equation (8) or equation (12). Thus by separation of d in both equations and equating the results,

$$\mathfrak{S} = \frac{\mu}{\sigma} \sqrt{\frac{p}{\rho}} \cdot \operatorname{tg} \alpha = \frac{C_1}{C_2} \cong \frac{530}{2100} = 0.25 \quad (13)$$

where

\mathfrak{S} - dimensionless invariant []

The criterion $\mathfrak{S} = 0.25$ either the tension or the shear principle dominates respectively. More corroboration to the theory is possible.

The theory is inclusive of the effects of physical properties such as surface tension, viscosity, and density; in addition to geometrical and operational conditions such as pressure and droplet size.

5. References

[1] AKESSON, N. B. 1952: Recent investigations of spraying accessories. *Proc. 4th Ann. Cal. Weed Conf.*, 58-64 p.
 [2] AMBERG, A. A. - BUTLER, B. J. 1969: High speed photography as a tool for spray droplet analysis. *ASAE Paper No. 69-140. St. Joseph, Mich.: ASAE*

[3] BAINER, R. - KEPNER, R. A. - BARGER, E. L. 1955: Principles of farm machinery. Wiley, 275-472 p.
 [4] EL-AWADY, M. N. - AFIFI, F. A. 1974: Spraying boom and nozzle modifications for improved application on cotton plants. *Annals of Ag. Sc., Faculty of Ag., Ain-Shams U., Cairo, Egypt.*
 [5] FRASER, R. P. 1958: The fluid kinetics of pesticidal chemical, advances of pest control research. ed. R. L. Metcalf, Part 2, Inetrscience Pub.
 [6] FRENCH, O. C. 1942: Spraying equipment for pest control. *Cal. Ag. Exp. St. Bul.* 666.
 [7] GERENCSÉR, A. 1981: A növényvédelemben használatos laposugarú szórófejek néhány kérdése. *Járművek és Mezőgazdasági Gépek*, Vol. 28. No. 7. 241-248 p.
 [8] HINZE, J. O. 1955: Fundamentals of hydrodynamic mechanism of splitting in dispersion processes. *Am Inst. Of Chem. Engrs.*
 [9] HOUGHTON, H. G. 1950: Spray nozzles. *Chem. Engrs. Handbook*, ed. J. Perry, McGraw-Hill: 1170-1175 p.
 [10] LANE, W. R. 1951: Shatter of drops in streams of air. *Indust. And Engg. Chem.*, No. 43, 1312-1317 p.
 [11] LÁSZLÓ A. 1979: A hidraulikus cseppképzés néhány áramlási problémájának vizsgálata, különös tekintettel a cirkulációs szórófejekre. *ATEK, Keszthelyi Mg. Kar Közleményei, Keszthely*, Vol. 21., No. 4., 28 p.
 [12] LÁSZLÓ A. in SITKEI Gy. ed. 1997: Gyakorlati Áramlástan. *Mg. Szaktudás Kiadó, Budapest*, 393-418 p.
 [13] LITTAYE, G. 1943: Sur l'atomization d'un jet liquide. *Compt. Rend.*, Oct. 215, 340-342 p.
 [14] VÖRÖS I. 1935: A cirkuláció és a kapillaris erők szerepe a cseppképzésben permetező szórófejeknél. *Diss. M. Kir. József Nádor Műegyetem*, 53p.
 [15] YOUNIS, S. M. 1969: Development of modified knapsack sprayer for effective control of cotton pests. *M.S. Thesis in Ag. Engg., U. Alex., Egypt.*

PLANT PROTECTION IN LINE WITH CONSUMER AND ENVIRONMENTAL PROTECTION

H. Ganzelmeier

Federal Biological Research Centre, Braunschweig

1. Introduction

The re-organisation of consumer protection in Germany has led to a broad dialogue pointing in a new direction for future plant protection policies. There is no doubt that sufficient possibilities must be made available to the users of plant protection products to prevent and control harmful organisms and non-parasitic impairments in plants in order to secure plant protection effectively for the future. The protection of human and animal health as well as the environment is of equal importance, meaning that the risk in applying plant protection products has to be kept as low as possible. Therefore a reduction programme has still to be defined. It is a well known fact that Germany's agriculture cannot refrain from the use of modern technology if it is to stay competitive.

2. Benefits and negative effects of chemical plant protection

In order to supply mankind with sufficient food, crops have to be cultivated, their health must be maintained and the harvested produce protected.

In spite of large efforts by research, the development of non-chemical procedures for plant protection falls short of expectations. Chemical plant production products therefore still represent the most significant measure in plant protection today, and most certainly also for the near future. The efforts concerning environmentally friendly plant protection have had a strong influence on the development of chemical plant protection products. In the process of testing and authorising plant protection products, toxicological assessments are no longer the only assessments; possible effects on the environment are also taken into account. As part of this progress, water pollution has decreased significantly within the last few years.

The general public has not really been aware of these changes in chemical plant protection. The fact that the public sees things in a different light has become evident in a survey concerning the risk factors connected to food, fig.1. Not only man-made chemicals, but also natural toxins should also be included in the ongoing discussion about the quality and safety of food in order to obtain a complete picture [1]. The listing of risk factors by consumers and scientists show totally different assessments. This is also a challenge for science in the future in the interests of an objective and effective consumer protection.

There is no doubt about it, every agricultural activity and every plant protection measure has its consequences. All plant protection measures have their positive effects and side-effects and involve costs and risks. The most important advantages of chemical plant protection are compiled in the following illustration, fig. 2. In decision-making, these are factors which should be considered carefully and be compared with each other. Benefit-cost analyses concerning chemical plant protection show a clearly positive benefit-cost balance [2].

For the effective protection of the cultivated plant, chemical plant protection measures are still considered to be indispensable. The efforts of the last few years have led to a reduction of plant protection product doses per hectare as the example shows for Germany, fig. 3 [3]. This diagram also illustrates to what extent the Member States apply chemical plant protection products. Germany appears around the middle of the diagram.

3. Prerequisites for proper and sustainable plant protection

Plant protection users today must have a wide knowledge of the relevant legal provisions and must orientate their work around these.

Chemical plant protection is characterised by

- a high quality **plant protection product authorisation procedure**, which only allows reliable products to be placed on the market,
- reliable **plant protection equipment** in perfect working order, which meets minimum technical standards, helping to avoid unnecessary stress to humans, animals and the environment and
- **users with expert knowledge**, fig. 4.

3.1 High quality plant protection product authorizations

The demands on plant protection products result from the requirements of plant, environmental, consumer and operator protection. This is one of the reasons why plant protection products belong to the most thoroughly examined chemical substances.

Plant protection products in Europe are **authorised** in accordance with Directive 91/414/EEC, fig. 4. The latter provides the basis for harmonising the authorisation of plant protection products in the EU. The European authorisation procedure is characterised by the following, fig. 5.

3.2 Reliable plant protection equipment

Plant protection equipment has developed into precise and reliable machinery. This is largely due to the fact that such equipment now has to fulfil strict requirements with regard to protection of the environment and the operator, work safety, impact and operator comfort. Today's plant protection equipment, whether mounted, trailed or self-propelling, fulfils these high standards.

Current technical developments in plant protection technology can be summarised as follows:

- Precision farming, a development which includes the entire span of plant production and which distances itself from one uniform treatment, moving towards site-specific application, taking into account the heterogeneity of fields.
- Transition to spray computers which work on the basis of ISO BUS (ISO 11783) and thus have no compatibility problems. This provides important prerequisites which are necessary for the documentation of whole-field- and site-specific cultivation and treatment.
- Field sprayers with greater working widths and tank sizes for increasing performance (hectare/hour).
- Air-assisted sprayers with improved blowers and adjustable features for the precise and economic application of plant protection products, including the use of modern sensor technology (nozzles, blowers). In addition to the identification of gaps efforts are now being intensified to adjust application even more precisely to the structure and density of bush and tree cultures (fruit growing and viticulture). To this end, an application map is employed, which takes into account the spatial extent of the foliage and steers the plant protection equipment with the corresponding nozzle configuration.
- The increasing use of drift reduction technology (injection nozzles) and operating measures for drift reduction in arable farming, viticulture, fruit and hop growing and subsequent decreased buffer zones to surface water or terrestrial biocoenosis instead of having to maintain fixed wider buffer zones as they still exist for standard equipment.
- Implements for equipment to increase the quality of application and operator handling such as circular pipe systems for field sprayers, boom suspension, cleaning devices and so on.
- Due to reasons of water protection, it is extremely important that plant protection equipment is cleaned properly. Plant protection equipment must be improved in this regard and the

cleaning of equipment combined with certain requirements (the field, the washing area, biobeds).

Plant protection equipment is also regulated strictly in Germany. According to the Plant Protection Act, manufacturers and distributors are obliged to only place on the market plant protection equipment which fulfils the minimum legal requirements. The BBA administrates plant protection equipment which complies with legal requirements in a so-called 'plant protection equipment list' and publishes this in the official Federal Gazette. Furthermore, the BBA has been testing plant protection equipment for several decades; the technical performance is measured and the equipment is tested in practice. This voluntary testing also includes the classification of plant protection equipment with regard to drift (50, 75, 90, 99%), table 1. Drift reducing plant protection equipment has become increasingly significant in Germany since such techniques can reduce buffer zones to water or terrestrial non-target areas, fig. 6.

Other EU Member States are also discussing the possibility of introducing legally binding examinations for plant protection equipment – similar to in Germany. The testing institutes in Europe will co-ordinate voluntary tests for agricultural machinery with each other in the context of the European Network for Testing of Agricultural Machinery (ENTAM). The aim of this network is the mutual acceptance of test results and the notion "once inspected, accepted all over Europe".

The compulsory inspection of plant protection equipment already in use in Germany was extended in 2002 to include air-assisted sprayers for use in fruit growing, viticulture and hops. Equipment inspections are also regarded as important in other EU Member States for reasons to do with the environment and operator protection; numerous different activities are now run. European and international standardisation play a vital role in the harmonisation of technical regulations for plant protection equipment, which is the basis for mutual acceptance of tested and inspected plant protection equipment.

Plant protection equipment is now constructed so that all plant protection products applied are highly biologically effective. This also applies to drift reducing plant protection equipment which has been proven in extensive studies to be consistently biologically effective.

3.3 Observing principles of "Good Professional Practice"

In accordance with German legislation the operator applying plant protection products on farms, in horticulture or in forestry must be reliable enough to do so and possess the necessary knowledge and skills [5, 6]. This means that the user must possess **expert knowledge** and have the necessary professional knowledge and skills expected for **good professional practice in plant protection**. The necessary professional knowledge and skills must be proved to the designated authority on demand. The procedure of providing evidence of expert knowledge is governed by a separate ordinance.

Plant protection products may only be applied in accordance with good professional practice, as stated in the German Plant Protection Act [3]. Good professional practice is aimed mainly at the application of plant protection products, but also incorporates other measures to do with plant protection. Each person carrying out plant protection measures must also take into consideration preventative arable and agronomic farming or other non-chemical measures. Good professional practice is a fundamental strategy and a standard for action which helps to discriminate between proper and improper action.

We understand the term 'good professional practice' to include plant protection measures which

- are considered to be scientifically safe,
- are recognised as suitable, appropriate and necessary on the grounds of practical experience,

- are recommended by the official extension services and
- are known to professional users.

In the following, some important principles of **good professional practice** are explained when using field sprayers and air-assisted sprayers: the handling of the plant protection equipment is the focus of interest, table 2.

If good professional practice is not observed, farmers may be penalised by having their EU subsidies cut [7].

4 Concluding remarks

Chemical plant protection is still thought of as essential for the effective protection of crops.

Plant protection products are responsible to a large extent for securing sufficient high quality food.

Both the benefits and negative effects of chemical plant protection are explained with the aid of examples.

Considerable progress has been made in environmental and health protection.

Plant protection products in Europe are authorised in accordance with Directive 91/414/EWG

EN/ISO norms are used to harmonise requirements for plant protection equipment. The present technical/operational developments in plant protection techniques are characterised by

- extensive research on precision farming
- development of spray computers on ISO Bus basis (ISO 11783)
- field sprayers with even higher capacities (up to 42 m working width, 7000 l tank size)
- increase in drift reducing techniques
- improvements to operator comfort
- improved cleaning devices for equipment

Correct and proper plant protection using plant protection products goes hand in hand with good professional practice. Many recommendations and advice for handling the products exist which the user must observe when using the equipment. If these are not observed, EU subsidies for users can be curtailed.

References

- [1] Bast, A. (2002): Risk to eat: natural versus man-made toxins. Book of Abstracts of 10th IUPAC International Congress on the Chemistry of Crop Protection, Basel, August 4 to 9, 2002, p. 13.
- [2] Schmitz, P. Michael u.a. (2002): Nutzen-Kosten-Analyse Pflanzenschutz. Wissenschaftsverlag Vauk Kiel KG, ISBN 3-8175-0356-3.
- [3] Ganzelmeier, H. (2001): Pflanzenschutztechnik und Pflanzenschutzgeräteprüfung im Wandel der Zeit. Nachrichtenbl. Deut. Pflanzenschutzd. 53(10), p. 242-262.
- [4] Rautmann, D. (2001): Die Verzahnung der Prüfung der Pflanzenschutzgeräte mit der Zulassung der Pflanzenschutzmittel. Nachrichtenbl. Deut. Pflanzenschutzd. 53 (10), p. 270-273.
- [5] Anonymus (1998): Gute fachliche Praxis im Pflanzenschutz. Bundesministerium für Ernährung, Landwirtschaft und Forsten, Bonn.
- [6] Burth, U. und B. Freier (2001): Gute fachliche Praxis und integrierter Pflanzenschutz – Eine Standortbestimmung. Neue Landwirtschaft, NL-Sonderheft Pflanzenschutz, Deutscher Landwirtschaftsverlag, S. 10-14.
- [7] Ripke, F.-O. (2001): Wo Sorgfalt fehlt, droht Bußgeld. Neue Landwirtschaft, NL-Sonderheft Pflanzenschutz, Deutscher Landwirtschaftsverlag, p. 26-28.

Table 1 Sprayers that have proved a significant reduction of drift and which additionally have got the BBA-approval are entered in the register „loss reducing equipment“. Here an extract of field sprayers. BBA: November 2004

Type of field sprayer or implement for field sprayer	Regulation of use	
	spray pressure, [bar]	nozzle height, [cm]
drift reduction class 50%		
Agrotop TD 025 API 110	4,0	75
Agrotop TD 110 04	2,5 to 3,0	75
Agrotop Airmix 110-03	1,5 to 2,0	50
Agrotop Airmix 110-04	1,0 to 2,0	50
Agrotop Airmix 110-05	1,5 to 6,0	50
ALBUZ AVI 110-03	3,0 to 7,0	50
ALBUZ AVI 110-04	3,0 to 7,0	50
Hardi S Injet 02, Lechler ID 120-02 C, Lechler ID 120-02 POM	3,0 to 3,5	50
Hardi S Injet 025, Lechler ID 120-025 C, Lechler ID 120-025 POM	3,0 to 5,0	50
Hardi S Injet 03, Lechler ID 120-03 C, Lechler ID 120-03 POM	3,0 to 8,0	50
Hardi S Injet 04, Lechler ID 120-04 C, Lechler ID 120-04 POM	3,0 to 5,0	50
Hardi Minidrift MD-025-110	1,0 to 2,0 bar	50
Hardi Minidrift MD-03-110	1,0 to 2,0 bar	50
Hardi Minidrift MD-04-110	1,0 to 3,0 bar	50
Hardi Minidrift MD-05-110	1,0 to 4,0 bar	50
John Deere Twin Fluid 35	3,0 to 5,0, air pressure 0,35	50
John Deere Twin Fluid 35	4,0 to 5,0, air pressure 0,35	75
John Deere Twin Fluid 42	3,0, air pressure 0,35	50
Lechler IDK 120-025	1,5 to 2,0	50
Lechler IDK 120-04 POM	1,0 to 3,0	50
Lechler IDK 120-05 POM	1,0 to 4,0	50
Lechler IDN 120-025	1,0 to 6,0	50
TeeJet AI/AIC 110 025 VS	3,0 to 4,0	50
TeeJet AI/AIC 110 03 VS	-	50
TeeJet AI/AIC 110 04 VS	2,5 to 4,0	50
TeeJet AI/AIC 110 05 VS	3,0 to 5,0	50
HARDI COMMANDER plus TWIN FORCE, Variants with 18, 20, 21, 24, 27 and 28 m all with nozzle Hardi ISO-F 110-02 or Hardi ISO-F 110-03	spray pressure max. 2,5 bar, airflow 140 bar, minimum crop height 30 cm	
HARDI Alpha, Variants with 18, 20, 21, 24, 27 and 28 m all with nozzle Hardi ISO-F 110-02 or Hardi ISO-F 110-03	spray pressure max. 2,5 bar, airflow 140 bar, minimum crop height 30 cm	
drift reduction class 75%		
Agrotop AirMix 110-04	1,0	50
Agrotop AirMix 110-05	1,0 to 1,5	50
Hardi S Injet 03, Lechler ID 120-03 C, Lechler ID 120-03 POM	3,0	50
Hardi S Injet 04, Lechler ID 120-04 C, Lechler ID 120-04 POM	3,0	50
Hardi S Injet 05, Lechler ID 120-05 C, Lechler ID 120-05 POM	2,0 to 8,0	50
TeeJet AI/AIC 110 03 VS	3,0 to 8,0	50
TeeJet AI/AIC 110 04 VS	3,0	50
TeeJet AI/AIC 110 05 VS	3,0	50
TeeJet Minidrift MD-04-110	1,0	50
TeeJet Minidrift MD-05-110	1,5	50
John Deere Twin Fluid 35	5,0, air pressure 0,35	50
Lechler IDK 120-03 POM	1,0	50
Lechler IDK 120-04 POM	1,0	50
Lechler IDK 120-05 POM	1,0 to 1,5	50
Lechler IDN 120-025	3,0	50
TeeJet AI 110 04 VS	3,0	50
TeeJet AI 110 05 VS	3,0	50
Dammann ANPA, Variants with air assistance DAS and 24 up to 28 m working width all with nozzle Lechler ID 120-03 C, Lechler ID 120-03 POM, TeeJet AI 110 03 VS, Teejet AI 110 04 VS, TeeJet AI 110 05 VS, Agrotop AirMix 110-04, Agrotop AirMix 110-05, AlbuZ AVI 110-03, AlbuZ AVI 110-04	Spray pressure at Agrotop AirMix 110-04 1,0 bar Agrotop AirMix 110-05 2,0 bar otherwise 3 bar fan drive at maximum (160-170 bar), min. crop height 50 cm	
HARDI COMMANDER plus TWIN FORCE, Variants with 18, 20, 21, 24, 27 and 28 m all with nozzle Hardi ISO-F 110-04 or Hardi ISO-F 110-05	spray pressure 3 bar, full airflow, minimum crop height 50 cm	
HARDI Alpha Variants with 18, 20, 21, 24, 27 and 28 m all with nozzle Hardi ISO-F 110-04 or Hardi ISO-F 110-05	spray pressure 3 bar, full airflow, minimum crop height 50 cm	
drift reduction class 90%		
Agrotop AirMix 110-05	1,0	50
Hardi S Injet 05, Lechler ID 120-05 C, Lechler ID 120-05 POM	2,0	50
Hardi Minidrift MD-05-110	1,0	50
Lechler IDK 120-05 POM	1,0	50
Lechler IDN 120-025	2,0	50
Lechler ES 90-02 brass and ES 90-02 POM	line spraying	
Lechler ES 90-03 brass	line spraying	
Lechler ES 90-04 POM	line spraying	

Table 2

Good professional practice in plant protection	
<i>General principles and advice for the intended and appropriate use of plant protection equipment – field sprayers –</i>	
1.	New sprayers must meet minimum requirements and be entered in the plant protection equipment list.
2.	Field sprayers which are already in use must be tested once every two years by officially approved test stations.
3.	Preference must be given to loss reducing equipment (list of loss reducing equipment).
4.	Check dosing accuracy before use: inspect the plant protection product, growth stage and weather conditions.
5.	Observe protective measures for the user. When mixing the spray liquid, the instructions for use of the PPP- (product application rate, suitability for mixing, etc.) must be observed, together with the required precautionary and operator protection measures.
6.	The filling of sprayers must take place under supervision. The flow of spray liquid back into the drinking water pipe must be ruled out
7.	PPP containers have to be rinsed thoroughly after emptying. The rinsing water must be directed into the spray tank. An induction bowl with an integrated container rinsing facility is particularly suited for this purpose. Clean containers are taken back free of charge.
8.	In order to prevent residual volumes of spray liquid, the amount of liquid for the last filling has to be calculated exactly. The tank should be filled with somewhat less than calculated. The rinsing water accumulated after internal cleaning is applied to a remaining small untreated plot.
9.	Adjust the sprayer to the respective crop.
10.	Application of plant protection products must be precise and low on drift, 6 (8) km/h should not be exceeded.
11.	No application at wind speeds > 5 m/s, temperatures > 25°C or humidity <30%.
12.	Observe buffer zones (non-spray zones) to water / biotopes under protection. The prevailing wind direction has to be accounted for if close to endangered objects (i.e. residential areas, gardens, leisure areas and sports grounds) and/or drift reducing measures must be observed (switching off exterior nozzles, lower spray pressure).
13.	Immediately after spraying, the interior of the sprayer has to be cleaned with clear water from an additional water tank. The rinsing water has to be applied to a remaining untreated plot.
14.	Minor amounts of rinsing water which have been diluted several times may remain in the tank if necessary.
15.	External cleaning should take place on an area which has to be treated anyway.
16.	Correct operation and dosing and distribution accuracy can only be guaranteed if the plant protection equipment is looked after and serviced properly.
Good professional practice in plant protection	
<i>With respect to air-assisted sprayers for orchards, vineyards and hops, the following advice should be heeded either in addition or alternatively:</i>	
1.	Sprayers should be adjusted to a specific and loss-reduced application according to the spatial extension of the individual crop. In this respect, particular attention should be paid to drift reducing measures.
2.	The fan air volume should be adjusted to the respective crop, and preferably be low. An application across several rows should be avoided.
3.	The water volume and product application rate are determined according to the developmental stage and/or the crown height (fruit growing).
4.	If the product is applied next to endangered objects (i.e. residential areas, gardens, leisure areas and sports grounds) the crops should be treated from only one side, and the spray be directed towards the area to be treated.
5.	Sprayers which are already in use must be tested once every two years by officially approved test centres.
6.	For aircraft applications, the BBA guidelines and the relevant regulations of the German Federal State authorities must be observed.

Risk for the consumer through food		
Risk factors	Assessed by	
	consumer	sientists
● Adjuvants / Contamination (preservatives / ppp-residues)	1	3
● Environmental problems (sewage sludge, lead)	2	5
● Unbalanced nutrition / food (fast food)	3	4
● Natural toxins (mould, mycotoxns)	4	2
● Microbiological contamination (salmonella, bacteria)	5	1

Source: Dr A. Bast

Plant Protection Products-Authorisation in accordance with Directive 91/414/EWG

- New and existing active substances are evaluated in extensive procedures at EU-level and accepted active substances are registered in a „Positive List“
- The Member States (MS) remain responsible for authorisation, PPP are only authorised if the active substances are included in the „Posit.List“
- Assessment and authorisation of PPP in accordance with uniform principles, if unacceptable effects occur, risk mitigation measures are applied or authorisation is refused
- Label-use-authorisation is set (field of application and directions for use are determined precisely)
- PPP which are authorised in other MS must also be authorised in Germany (on application)
- Imports of PPP only allowed if the product is identical with a product authorised in Germany
- Plant resistance improvers and adjuvants must be registered at the BBA

Directions for use for the protection of surface water

Measures to be fulfilled: Compliance of buffer zones (dependent on the ppp)



Flexible buffer zones are possible through

Consideration of application conditions:

Use of drift reducing sprayers

Size of running water

Riparian vegetation

Pre-conditions for proper and sustainable plant protection

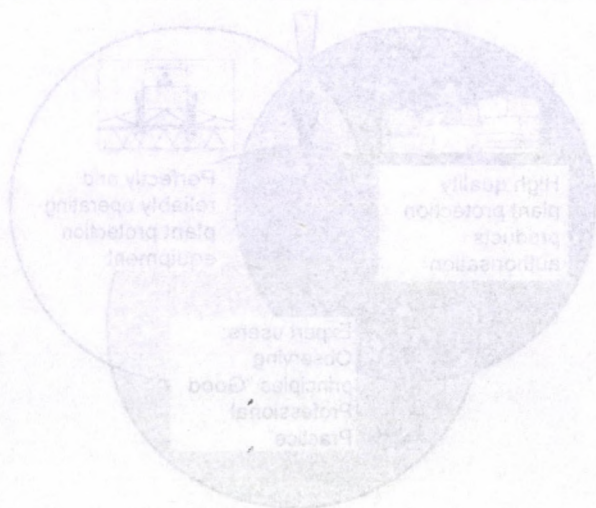

IMPROVING GERMINATION AND WATER ADDITION PARAMETERS OF SEEDS WITH ELECTROMAGNETIC TREATMENT

L. Bense – E. Joó – P. Szendrő – Gy. Vincze
Szent István University, Gödöllő

1. Introduction

It is known that all essential metabolism processes of life are guided by genes in this way they create selective enzymes. Enzymes are biocatalyzators, which take part in autocatalytic processes. Enzymes consist of two subsystems: coenzyme which determines the direction of catalyzed process and the apoenzyme. The material quality of the substrate molecule is determined by apoenzyme. In chemical respect living substances are considered as thin solution since among its components water is dominant. Consequently the chemical reaction has been proceeded in a thin solution. Participants of the reaction are the substrate molecule (protein) and the enzyme protein giant molecule. With comparing the reaction partners by sizes it is determined that the chemical reaction is proceeded in a relatively small part of the enzyme which part is called active region. The chemical activity is a kind of "distance effect" since because of the wet solution the surface of the enzyme is always covered with a thickness of a few molecule layers of water. In electric respect living protein is considered as semi-conductor with a relatively big (2-3eV) forbidden band [1, 2, 3], this feature as it is proved [4] is being developed in the case of wetted protein. The dry, lifeless (chemical and electric inactivity) protein is insulator [4]. It is important that a quasi-crystal structured water or water in monomer state is being around the enzyme. That is to say the operation of active region has better efficiency in settled water covering than in unstructured. On the one hand the reason for this is that the electric permittivity of structured water is $\epsilon_r = 3-5$ while of unstructured water is: $\epsilon_r = 75-85$, on the other hand hydrogen bond is transmitted through the settled water. Briefly structured water is the transmitter of hydrogen bond.

2. Germination model of vegetable seeds

The enzyme – substrate autocatalytic reaction can be described with the following equations:

- Complex formation from S substrate and E enzyme molecule:



- dissolve into T reaction product and the enzyme:

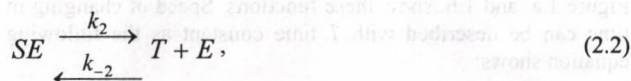

Figure 1 shows the dissolution.

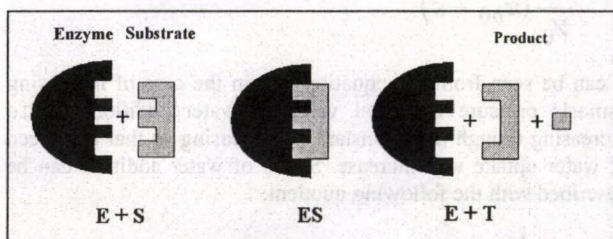

Figure 1 Illustration of the autocatalytic reaction on the basis of equations (2.1) and (2.2)

From this equations can be resulted the product concentration $[T]$ with respect to time

$$[T] = [T_\infty] \frac{1}{1 + e^{-[T_\infty][E] \left(k_3 \frac{k_1}{k_{-1}} + k_{-3} \right) (t - T_{half})}}, \quad (2.3)$$

which is a logistic graph. Here square brackets show the concentrations and k_i ($i = 1, -1, 3, -3$) are the speed factors of reactions. A shown from equation (2.3) at the time $t = T_{half}$ concentration is the half of the final value $[T_\infty]$. That is where the name arises from.

The equation is cannot be compared with experiments because the measurement of the inner seed concentration is in vivo impossible. That is why the constants of the equation is determined from the results of germination experiments. First of all it is supposed that among many enzymatic reactions of the seed germination the slowest one is exist which determinates the evolution in time of the whole process. Germination is modelled only with this process. Furthermore it is supposed that the germination (it is visible while observing) of the seed occurs near a critical $[T]$ concentration value. It means that the reaction as shown in Figure 1 launches in certain product concentration when the collision probability of SE and T is big enough. Germination has two well-separated periods. The one is the latent time when apparently nothing happens and the other when the germination as shown in equation (2.3) launches. The critical value of product concentration is being evolved in the first period. Furthermore it is supposed that the value of all sprouting seeds is one and the value of all unsprouting seeds is zero. Ultimately it is supposed that the division where N number of sprouting seeds is divided by N_{tot} number of seeds participate in all germination samples is proportion to $[T]$ concentration. In this case instead of the previous equation the following can be described:

$$\frac{d \frac{N}{N_{tot}}}{dt} = \left(k_3^* \frac{k_1}{k_{-1}} + k_{-3}^* \right) \left(\frac{k_3 \frac{k_1}{k_{-1}} [S_0] - \frac{N}{N_{tot}}}{k_3 \frac{k_1}{k_{-1}} + k_{-3}} \right) \frac{N}{N_{tot}}. \quad (2.4)$$

This equation can already be compared with the experiment and the constants of the equation can be determined. For this determination it is enough to describe the general solution of the equation and to determine the constants with germination experiments. The final value of germination number is:

$$[N_\infty] = N_{tot} \frac{k_3 \frac{k_1}{k_{-1}} [S_0]}{k_3 \frac{k_1}{k_{-1}} + k_{-3}} \quad (2.5)$$

that is to say germination ability depends on the initial concentration of substrate molecules which are able to the reaction. Reaction ability means that the molecule has enough energy and is covered with structured water shell. Through this shell the electric field of the active region can penetrate with small reduction or the hydrogen bond can be evolved. Accordingly germination ability can be connected with the number of substrate molecules with reaction ability at initial time. From this statement above it is clear that the germination ability can be influenced by the structuring of water. The reaction rate in equation (2.4) is proportion to the concentration of enzyme molecules with reaction ability:

$$k = k_3^* \frac{k_1}{k_{-1}} + k_{-3}^* = \left(k_3 \frac{k_1}{k_{-1}} + k_{-3} \right) [E]. \quad (2.6)$$

This concentration - as it was realized before - is bigger in the case of structured water. Otherwise by reason of the kinetic theory, k is [5]:

$$k = DZ_{SE}e^{-\frac{W_{SE}}{kT}} \quad (2.7)$$

where D is the steric factor, Z_{SE} is the number of molecular collisions per second, which creates SE complex in a unit volume and W_{SE} is the activating energy. Steric factor is a collision-geometrical factor which is obviously bigger when the enzyme and the substrate is covered with structured water since the active region where the catalysis is efficient expands. The Z_{SE} collision frequency is inversely proportional to the denaturing time of the enzyme. It is smaller when the enzyme is covered with structured water layer than in the case of unstructured water since the conduction of heat is better. Consequently the water structure in the seed which can be influenced with electric treatment stimulates the germination firmness. The germination experiments have backed up the correction of the theory and have proved that the treatment time has an optimal value indeed where the germination ability is the biggest. This phenomenon is described with the following Figure 2 for onion seed:

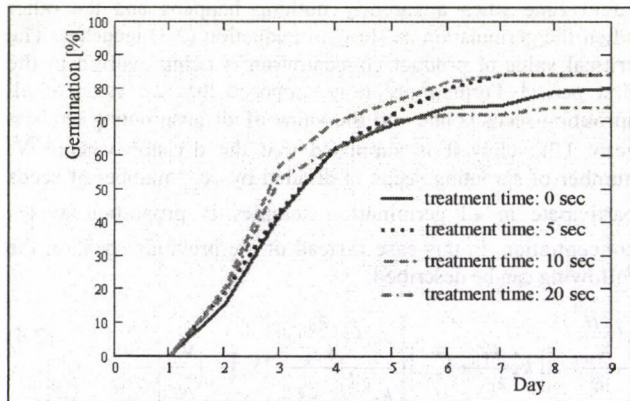

Figure 2 Germination data of onion as parameters of treatment time

It is well-read from Figure 2 that the optimum treatment time in this case is 10 s and that the radiation of 20 s has already damaged some part of the seeds.

3. Water uptake model of vegetable seeds

To penetrate into the cells of embryo, water has to penetrate through the plasma membrane and through the tonoplast. In physical respect these two membranes are substituted for a single potential barrier. Water molecules have to get across this potential barrier. The driving force of the water transport is the difference between the pressures of external and internal sides of the membrane. So the result of the water transport is the change of inner water volume (mass). Considering water incompressible, the balance equation of water addition for changing volume is:

$$\frac{d\Delta V}{dt} = I_V \quad (3.1)$$

where ΔV water volume changing of the cell, and I_V is the volumetric current of transported water. Volumetric current is commonly a complex function of pressure difference. In the case of small pressures it is supposed that this function relation is linear:

$$I_V = -LA[(p_b - p_k) - \pi_b - \pi_k] \quad (3.2)$$

In the above equation p_b and p_k is the internal (turgor) and external pressure, π_b is the inner osmosis pressure, π_k is the external osmosis pressure and finally L is the hydraulic conductivity of potential barrier and A is the surface of the seed. Osmosis pressures are evolved because of the component - selective permeability of the membrane. From the above mentioned two relations the differential equation of water uptake is the following:

$$\frac{d\Delta V}{dt} = -LA[(p_b - p_k) - \pi_b - \pi_k] \quad (3.3)$$

$$p_b = p_{b0} + \varepsilon \frac{\Delta V}{V_0}, \quad \pi_b = \pi_{b0} \left(1 - \frac{\Delta V}{V_0}\right) \quad (3.4)$$

The above mentioned equation of state (3.4) is resulted from the equation of state of water and from Roul't's equation of state. Zero index is the initial value. The external fluid is clear water. In this case $\pi_k = 0$ so the solution of the differential equation of water uptake is the following:

$$\frac{\Delta V}{V_0} = \frac{\pi_{b0} + p_k - p_{b0}}{\pi_{b0} + \varepsilon} \left(1 - e^{-\frac{LA}{V_0}(\pi_{b0} + \varepsilon)t}\right) \quad (3.5)$$

Considering that during the experiments the mass of the seed was measured, it is practical turning to the mass:

$$\Delta m = m_0 \frac{\pi_{b0} + p_k - p_{b0}}{\pi_{b0} + \varepsilon} \left(1 - e^{-\frac{LA}{V_0}(\pi_{b0} + \varepsilon)t}\right) \quad (3.6)$$

It can be seen from the solution that the changing of mass derives from water addition is in the exponential function of time and its final value is:

$$\Delta m_{final} = m_0 \frac{\pi_{b0} + p_k - p_{b0}}{\pi_{b0} + \varepsilon} \quad (3.7)$$

It is seen if the inner osmosis pressure is changes (e.g. by the effect of treatment) the final value will change in the function of:

$$\Delta \Delta m_{final} = m_0 \left[\frac{\pi_{b0} + p_k - p_{b0}}{\pi_{b0} + \varepsilon} + \frac{p_{b0} - p_k - \varepsilon}{(\pi_{b0} + \varepsilon)^2} \Delta \pi_{b0} \right] \quad (3.8)$$

Figure 1.a. and 1.b. show these functions. Speed of changing in time can be described with T time constant as the following equation shows:

$$T = \frac{1}{\frac{LA}{V_0}(\pi_{b0} + \varepsilon)} \quad (3.9)$$

It can be seen from the equation that in the case of increasing osmosis pressure the final value of water addition is also increasing though time constant is decreasing so that the speed of water uptake will increase. Speed of water addition can be described with the following quotient:

$$V_{water} = \frac{\Delta m_{final}}{T} = \frac{m_0}{T} \frac{\pi_{b0} + p_k - p_{b0}}{\pi_{b0} + \varepsilon} \quad (3.10)$$

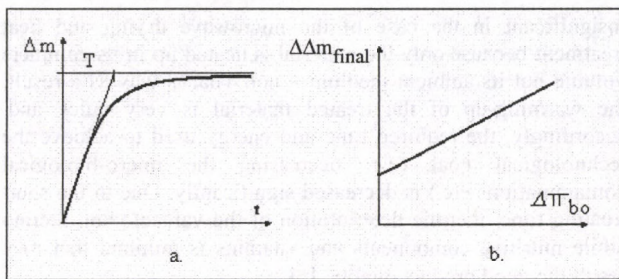

Figure 3 a.: Changing of seed mass in the function of time on the basis of the model, b.: Changing of saturated seed mass in the function of osmosis pressure on the basis of the model

It can be seen from the solution that the quicker is the water addition the bigger is the initial osmosis pressure. On the other hand former studies have been pointed to the fact that the electric treatment stimulates the water [6] this is why the water volume functioning as solvent was decreasing and on this the osmosis pressure was increasing. Roul't's equation of state shows this relation below:

$$\pi_{b0} = RT \sum_j \sigma_j c_{bj} \quad (3.11)$$

where σ_j is the reflection coefficient and c_{bj} is the concentration of the j the component of solution concerning the membrane.

It was elaborated a theory by Cosgrove and Vertucci concerning fine-structure of water uptake [4], [5].

Vertucci [1] has proved with microscopic snapshots that there is a layer touching the membrane nearby the cytoplasm which was consisted of vacant holes (vacuole). On the basis of this fact Cosgrove [2] has explained the water addition of seed that from the inner cell an ion solution was flowing into these holes so that the osmosis pressure increased which induced water transport. While increasing osmosis pressure increases water uptake and also its speed.

The experiments have backed up the correction of the theory. As an example Figure 4 shows the water uptake of tomato seed without treatment and then after a 10 seconds of electromagnetic treatment.

On the strength of Figure 4 it can be judged that the water uptake process of seeds is described correctly by the model. According to the statistical evaluation correlation of the sample

was $korr = 0,99$ without treatment and the final value of mass increase was $\Delta m_{final} = 8,252g$, and the speed of water addition was $V_{water} = 4,18 g/day$. In the case of 10 seconds of treatment the data above are the following: $korr = 0,984$, $\Delta m_{final} = 10,37g$, $V_{water} = 4,24 g/day$.

It can be seen that the effect of treatment is double: once it changes the speed of water uptake twice it increases the absorbed water mass.

4. Summary

Vegetable seeds can be stimulated with a treatment in electromagnetic field. This effect can be explained with the fact that the inner water of seed will be structured by the treatment so that the mass of the molecular water which functions as a solvent decreases however at the same time the mass of the structured water increases. At this time the inner osmosis pressure of the seed increases, which decrease the hydrodynamic pressure so that the pressure gradient which causes water transport will be bigger on the membrane. Experiments showed that germination ability is not correlated with water uptake. Consequently the treatment has at least double effect. The first is the structuring of the water the other can be the stress effect which produces the built-up of shock proteins. The first effect causes both the increasing osmosis pressure and the increased water addition and the second affects germination ability.

References

- [1] A. Szent-Györgyi: Science 93, 609, 1941
- [2] M.S. Evans & J. Gergely: Biochim. Biophys. Acta. 3, 188, 1949
- [3] B. Rosenberg: J. Chim. Phys. 36, 816, 1962
- [4] D.D. Eley: Horizons in Biochemistry, Eds.: M. Kahsa & B. Pullman, Acad Press. New York, 1962
- [5] H.J. Bittrich, D. Haberland, G. Just: Leitfaden der Chemischen Kinetik, VEB DAW Berlin, 1973
- [6] VINCZE GYULA – SZENDRÓ PÉTER – KOLTAY JENŐ – SZÁSZ ANDRÁS: A mágneses vektorpotenciál hatásának vizsgálata. (Observing the effect of magnetic vector potential). MTA Agrár Műszaki Bizottság. Kutatási és Fejlesztési Tanácskozás. Gödöllő. FVM Műszaki Intézet. 2002.

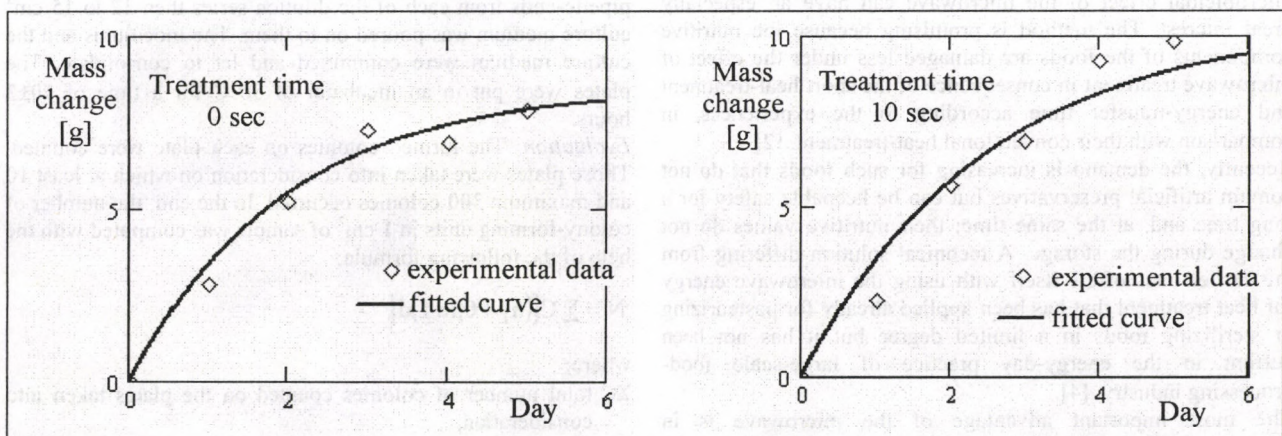

Figure 4 Evaluation of experimental results in the case of two different treatment time on the basis of the model

ON ISSUES OF FOOD – SAFETY OF MILK HANDLING BY MICROWAVE

K. M. Lukács – P. Sembery
Szent István University, Gödöllő

Introduction

The food-safety has had got an increasing importance during the last years in the European Union and in Hungary as well. The factors risking the safety of the foods can be classified as follows. [3]

- physical: foreign materials (glass, metal etc.),
- chemical: toxic materials,
- biological: disease germs (pathogens) and their toxins.

An important object during the food-processing that the fewest harmful microbes could get into the manufacture process, as far as it is possible, that means to decrease the vital functions of the pathogens and the bacteria causing deterioration of food.

The physiological advantages of consuming milk and dairy products are well known. The quality of the dairy products must be improved continuously to satisfy the more and more increasing consumer demands of which basic condition is the acceptable quality of the raw milk used in the manufacture of dairy products. [7]

There are always micro-organisms of less or larger number in the raw milk that get into the milk from the udder at first and then – during the milking, the milk – handling and the delivery (transport). The saprophyte micro-organisms occurring in the milk worsen the quality and keep ability of the milk with their life activity and the pathogens risk the health of the consumers. [1]

During the processing of milk, the micro-organisms or, at least, the great majority of them must be destroyed for the milk to be not harmful to the health of the consumers and, respectively, it to be keep able for a longer time and suitable for further processing.

In view-point of practice, three basic methods of the heat treatment can be differentiated as follows: [1]

- pasteurization,
- ultra-pasteurization and
- sterilization.

Several processes are known for decreasing the germ count. These are the conventional heat treatments, the ionizing exposures and the processes basing on microwave energy-transfer. [5] The results of the researches carried out during the last decades, with the goal to substitute the heat-treatment processes requiring frequently considerable work and energy, pointed out the large possibilities and, but not least, the economical advantages of applying the microwave energy as “clean energy source”. Experiments connected with the microbicidal effect of the microwave can have an especially great interest. The method is promising because the nutritive components of the foods are damaged less under the effect of microwave treatment in consequence of the short heat-treatment and energy-transfer time according to the experiences, in comparison with their conventional heat-treatment. [2]

Recently, the demand is increasing for such foods that do not contain artificial preservatives but can be keepable safety for a long time and, at the same time; their nutritive values do not change during the storage. A technical solution differing from the earlier ones offers itself with using the microwave energy for heat treatment that has been applied already for pasteurizing or sterilizing foods in a limited degree but it has not been current in the energy-day practice of large-scale food-processing industry. [4]

The most important advantage of the microwave is in connection with the heat generation in the interior of the product. It is due to the internal heating-up that the heat loss is

insignificant in the case of the microwave drying and heat treatment because only the material is heated up in its complete volume but its ambient medium – not. That is why as a result, the warming-up of the treated material is very quick and, accordingly, the required time and energy used to achieve the technological goal (e.g. decreasing the micro-biological contaminations etc.) is decreased significantly. Due to the short treating time, thermic deterioration of the valuable and thermo labile nutritive components and vitamins is minimal that may result the good product quality. [6]

Material and method

In the present phase of the research, the object is the investigation of the microwave treatment of milk and the changing in the shelf life and, respectively, the total germ count resulted from the treatment. During the experiments, samples of 2 dl volume from freshly milked and precooled (9°C) cow's milk were treated with the help of a microwave device type Whirlpool M263 Talent that is used in the households as well. During each measurement series, the treatment of the milk was carried out at 1000 W output power and for changed time. The samples were cooled back to room-temperature in every case by a thermostat of water bath and then the pH-values of the samples were measured repeatedly after every three hours in order to trace the measure of the shelf life (i.e. when the coagulation was observable). The temperature of the samples was measured by Cu-CuNi thermocouples and the ALMEMO measuring unit. The latter measuring unit completed with a pH-measuring probe made possible the continuous control of pH-values in of the samples.

At the second step, the total microbe count of the milk was determined by colony-counting in accordance with the standard MSZ ISO 6610:1993.

In carrying out these measurements, the accredited laboratory of the FODDMICRO Ltd. assisted. The matter of the standard is to determine the number of the microbes' colony-forming units (CFU) in milk. The principle of the method was that plate-mouldings with TGE culture medium and test sample of specified volume were prepared. The other plates were prepared under the same conditions using decimal dilutions of the experimental sample. The plates were kept in incubator under aerobic condition at a temperature of 30°C for 72 hours. Then the count of the microbes' colony-forming units (CFU) in 1 cm³ of the sample was determined that was based on the numbers of colony on those plates of which dilutions were suitable for counting.

Materials and instruments: Culture medium, diluting liquid, culture dish, micropipette, test tubes, incubator.

Testing process: After preparing the basic solution and its decimal dilutions, samples of 1 cm³ were taken with sterile pipette-ends from each of the dilution series then 12 to 15 cm³ culture medium was poured on to them. The inoculums and the culture medium were commixed and let to consolidate. The plates were put in an incubator of 30°C for a time of 70±3 hours.

Evaluation: The formed colonies on each plate were counted. Those plates were taken into consideration on which at least 10 and maximum 300 colonies occurred. In the end, the number of colony-forming units in 1 cm³ of sample was computed with the help of the following formula:

$$N = \sum C[(n_1 + 0, \ln_2) d]$$

where:

ΣC total number of colonies counted on the plates taken into consideration,

n₁ number of those selected plates on which 10 to 300 colonies were counted at the first valuable dilution,

- n₂ number of those selected plates on which 10 to 300 colonies were counted at the second valuable dilution,
- d diluting factor of the first valuable dilution.

Results and discussion

The pH-value of the fresh milk is between 6.6 and 6.7 – close to the inert value – that is advantages for the most microbes. The acidity – degree of the fresh milk does not change for a certain time. This period is named the incubation time. At the ending of the incubation period, the breed of the bacteria already begins but acidification cannot be indicated yet. The lower the germ account in the milk is after milking, the lower the storage temperature is and the more intensive the germicide effect is, the longer the incubation time will be. After the incubation period – as a result of the quick breed of germs –, the acid content of the milk increases slowly at first and then quickly (its pH-value decreases).

After the end of the incubation time in those samples, that had been heated up to a lower temperature, the indications of coagulation appeared at the 30th or 33rd hour following the treatment i.e. the lactic coagulation began, the pH-value started to change from the inert state to an acidic state. The pH-values of the samples showed a medium of increasing acidity until they reached the value of 4.7 that could be explained so that the lactobacilli bred up to a large number in these samples. (Table 1) Comparing these samples to each other, it could be established that the length of the incubation time grew with increasing the temperature and the number of bacteria began to decrease to a lower level due to the higher temperature as well. In the milk samples heated up to higher temperatures, the forming of lactic acid did not start in and, due to which, their pH-values remained in the inert range. However, the indication of the coagulation could be observed here as well but the changes in these samples were caused by heat-resisting spored microbes and not by lactobacilli.

The number of bacilli producing lactic acid had been managed to decrease in such a degree that their breed could not be detected and, accordingly, the pH-value of the milk did not change. The sudden decreasing in pH-values after the incubation time and the behavior curves of the samples treated at higher temperatures in the inert range can be seen well in Figure 1.

As the result of the total-germ-count tests, it can be established that the bacterium-count was larger in the samples treated at lower temperatures than in the samples heated up to higher temperatures (Figure 2). As a result of the effect of longer treating time, and the higher average ending temperature achieved in this way, the germs were destroyed as it was experienced by the measurement of the pH-values. The

remained bacteria (27%) were probably not the lactobacilli causing the lacto-acidic coagulation but other heat-resisting spored bacterium species. The identification of these species will be the object of the further investigations.

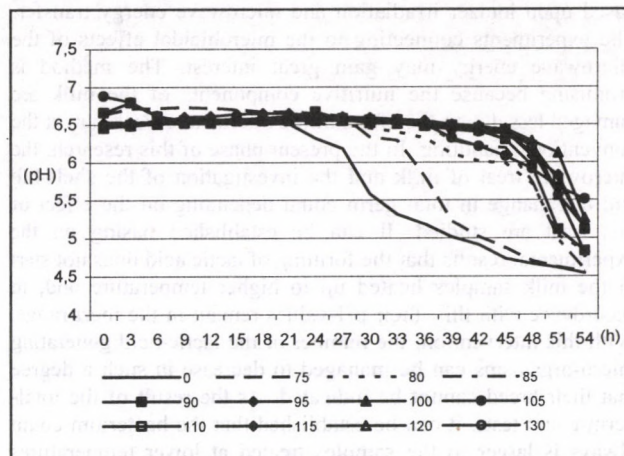

Figure 1 Changing of pH-value in the treated milk samples in function of the time

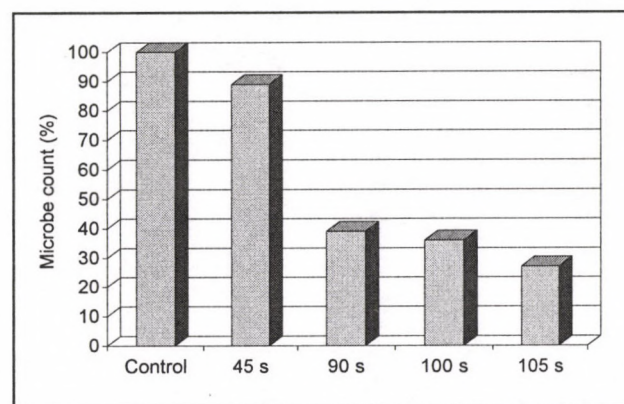

Figure 2 Effect of the treatments upon the total microbe-counts in function of the heat-treat

Summary

During processing food materials, the aim must be to ensure that less harmful microbes can get into the manufacture process as much as possible, i.e. to decrease the vital functions of the pathogens and bacteria causing deterioration. There always can be found micro-organisms of smaller or larger number in the

Table 1

Sample index	Treating time (s)	Achieved average temp. (°C)	Changing in pH after treatment (time scale in hours) (h)										
			0	6	12	18	24	30	33	39	45	51	54
1	0	22,0	6,54	6,53	6,52	6,51	6,32	5,58	5,31	5,01	4,73	4,61	4,54
2	75	49,9	6,63	6,72	6,72	6,67	6,65	6,33	6,29	5,22	4,87	4,62	4,56
3	80	51,8	6,47	6,51	6,54	6,53	6,51	6,45	6,40	6,11	5,98	5,03	4,83
4	85	56,2	6,49	6,55	6,57	6,55	6,56	6,54	6,53	6,29	6,19	4,98	4,58
5	90	63,3	6,66	6,61	6,56	6,57	6,67	6,56	6,56	6,49	6,30	5,11	4,83
6	95	64,8	6,48	6,52	6,54	6,55	6,55	6,54	6,53	6,49	6,38	5,56	4,81
7	100	65,5	6,50	6,51	6,52	6,56	6,55	6,55	6,55	6,48	6,44	6,12	5,26
8	105	71,3	6,88	6,62	6,56	6,59	6,59	6,56	6,56	6,32	6,08	5,67	5,51
9	110	76,2	6,47	6,53	6,57	6,58	6,58	6,56	6,55	6,49	6,43	5,76	5,11
10	115	84,1	6,52	6,54	6,61	6,65	6,62	6,59	6,57	6,50	6,41	5,83	5,11
11	120	86,3	6,46	6,53	6,54	6,55	6,55	6,52	6,51	6,47	6,40	5,56	5,16
12	130	103,1	6,47	6,53	6,55	6,56	6,56	6,54	6,53	6,43	6,38	5,56	5,14

raw milk that get from the udder at first and then during the milking, the handling and the transport (delivery) into the milk. For decreasing the germ count, there are several methods are known, these are the conventional heat-treats, the processes based upon ionizer irradiation and microwave energy transfer. The experiments connecting to the microbicidal effects of the microwave energy may gain great interest. The method is promising because the nutritive components of the milk are damaged less due to the effect of the microwave treat than at the conventional handling. In the present phase of this research, the microwave treat of milk and the investigation of the shelf-life and the change in total germ count depending on the effect of this treat are studied. It can be established basing on the experimental results that the forming of lactic acid does not start in the milk samples heated up to higher temperature and, in accordance with this, their pH-values remain in the inert range. With this intervention, the number of the lactic-acid generating micro-organisms can be managed to decrease in such a degree that their breed cannot be indicated. As the result of the total-germ-count tests, it can be established that the bacterium-count always is larger in the samples treated at lower temperatures than in the samples heated up to higher temperatures. The remained bacteria are not the lactobacilli causing lactic-acidic

coagulation probably but other heat-resisting spored bacterium species.

References

- [1] Balatoni M. - Ketting F. (1981): Tejipari kézikönyv (Handbook of Dairy Industry). Mezőgazdasági Kiadó, Budapest, p. 773
- [2] Bookwalter, G.N.,-Shukla, T.P.,-Kwolek, W.F. (1982.): J. Food Sci. 47:1683-1686
- [3] Csajági É. – Andrassy I. (2003): Élelmiszerbiztonság az Európai Unióban és Magyarországon (Food Safety in the European Union and Hungary). Európai Füzetek. 48.
- [4] Kovácsné L. M. – Sembery P. (2004): Mikrohullámmal kezelt tej mikrobiológiai vizsgálata (Microbiological Investigation of Milk Treated by Microwave). Veszprémi Kémiai Napok '04.
- [5] Rosenberg, U., Bogl, W. (1987): Food Technol. 41:92-99.
- [6] Sembery P. – Kovácsné L.M. – Douba M. (1999): Élelmiszer alapanyagok nagyfrekvenciás dielektromos jellemzői (Dielectric Properties of Food Materials). MTA AMB Kutatási Fejlesztési Tanácskozás, Gödöllő
- [7] Conjoint decree No.1/2003. (I.8.) FVM-ESZCSM

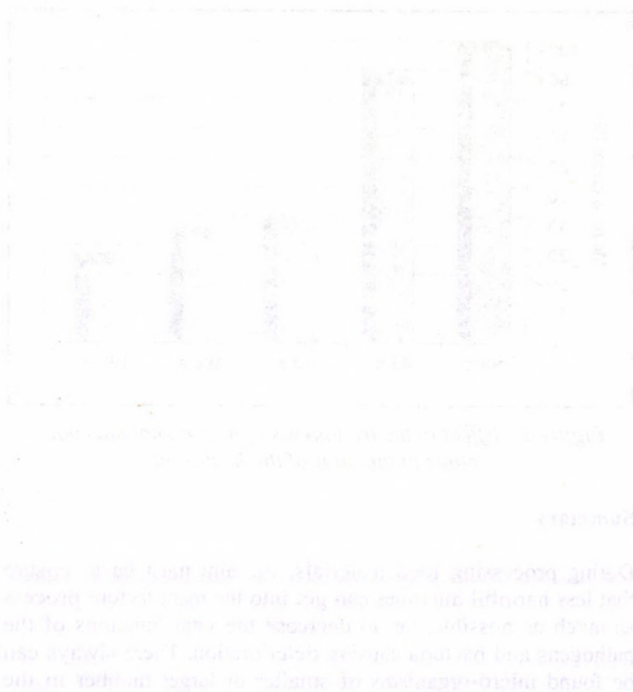

The graph illustrates the effect of microwave treatment temperature on the reduction of total germ count in milk over a 120-minute period. The y-axis represents the total germ count in log units, and the x-axis represents time in minutes. Four data series are shown for different treatment temperatures: 70°C, 80°C, 90°C, and 100°C. The 100°C series shows the most rapid and significant decrease in germ count, reaching a level below 10^2 log units by 120 minutes. The 90°C series shows a similar but slightly slower reduction. The 80°C series shows a moderate reduction, and the 70°C series shows the least reduction, with the germ count remaining above 10^4 log units even after 120 minutes. This indicates that higher microwave treatment temperatures are more effective in reducing the total bacterial load in milk.

Table 1

Time (min)	Total germ count (log units) after treatment (log units)											
	70°C	80°C	90°C	100°C	70°C	80°C	90°C	100°C	70°C	80°C	90°C	100°C
0	10.0	10.0	10.0	10.0	10.0	10.0	10.0	10.0	10.0	10.0	10.0	10.0
15	9.5	9.0	8.5	8.0	9.5	9.0	8.5	8.0	9.5	9.0	8.5	8.0
30	9.0	8.5	8.0	7.5	9.0	8.5	8.0	7.5	9.0	8.5	8.0	7.5
45	8.5	8.0	7.5	7.0	8.5	8.0	7.5	7.0	8.5	8.0	7.5	7.0
60	8.0	7.5	7.0	6.5	8.0	7.5	7.0	6.5	8.0	7.5	7.0	6.5
75	7.5	7.0	6.5	6.0	7.5	7.0	6.5	6.0	7.5	7.0	6.5	6.0
90	7.0	6.5	6.0	5.5	7.0	6.5	6.0	5.5	7.0	6.5	6.0	5.5
105	6.5	6.0	5.5	5.0	6.5	6.0	5.5	5.0	6.5	6.0	5.5	5.0
120	6.0	5.5	5.0	4.5	6.0	5.5	5.0	4.5	6.0	5.5	5.0	4.5

SIMILARITY THEORY OF STRUCTURED AGRICULTURAL FLUIDS

L. Bense – E. Joó – P. Szendrő – Gy. Vincze
Szent István University, Gödöllő

1. Introduction

Nowadays the solution of complex non-Newton fluid mechanics problems is not possible even with the help of informatics so that the features of flow must be determined with experimental way. The experimental arrangement (in order to decrease costs) is geometrically a reduced-size copy of the real process: it is so-called a reduced scale model. Measurement results of the reduced scale model could be applied even if the similarity conditions are given.

2. Conditions of similarity in the case of non-Newton flow

In the case of non-Newton flow the basic condition of analogy is the similarity in geometrical meaning. Movement of the fluid is described with the equation of motion. The solution of this equation is unambiguous which feature is proved by border and initial conditions. So in dynamic respect the flow of the real fluid and the reduced scale model is similar even if their equations of motion and unambiguous conditions are the same. In what follows the study is specializing on equations of motion and is not dealing with unambiguous conditions. Similar equation of motion means similar impulse scales and similar material equation. Look at impulse scales first! Suppose a system which can be seen on Figure 1.a. and its reduced scale model on Figure 1.b.

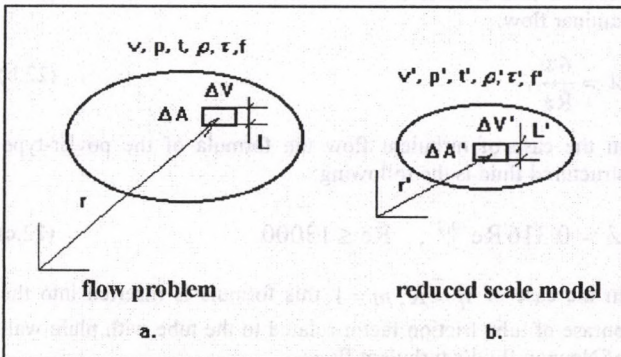

Figure 1 Sketch for drawing up the similarity theory

Select 1-1 small region in compliance with each other from the system and from the reduced scale model and determine the equation of scales of the impulse:

$$\int_{\Delta V} \rho \cdot \bar{v} \cdot dV = \int_{\Delta V} \bar{f} \cdot dV - \int_{\Delta A} p \cdot dA + \int_{\Delta A} \bar{\tau} \cdot dA \quad (1)$$

$$\int_{\Delta V'} \rho' \cdot \bar{v}' \cdot dV' = \int_{\Delta V'} \bar{f}' \cdot dV' - \int_{\Delta A'} p' \cdot dA' + \int_{\Delta A'} \bar{\tau}' \cdot dA' \quad (2)$$

Quantities with apostrophes are related to the reduced scale model. Since the regions are quite small the following equation can be described on the basis of average value theory of integrate calculation:

$$\rho \cdot \bar{v} \cdot \Delta V = \bar{f} \cdot \Delta V - p \cdot \Delta A + \bar{\tau} \cdot \Delta A \quad \text{furthermore} \quad (3)$$

$$\rho' \cdot \bar{v}' \cdot \Delta V' = \bar{f}' \cdot \Delta V' - p' \cdot \Delta A' + \bar{\tau}' \cdot \Delta A' \quad (4)$$

Quantities of the equations indicate an average value. For the sake of simplicity the difference between these values and their local value is not signed. Determine the relation between physical quantities of real system and reduced scale model in compliance with each other:

$$L' = C_L L, \quad t' = C_t t, \quad \bar{v}' = C_v \bar{v}, \quad \rho' = C_\rho \rho, \quad p' = C_p p, \quad (5)$$

$$\tau' = C_\tau \tau, \quad f' = C_f f$$

where L and L' are the typical linear sizes of the system and of the reduced scale model. For example in the case of tube the dimension of tube diameter and in the case of C constants with suffix the dimension of physical quantities' proportion in compliance with each other are given by L and L' . Not all of the C factors are independent since the factor of length – the time – and the speed has to be suitable for the relation below:

$$C_v = \frac{C_L}{C_t} \quad (6)$$

With inserting terms (5) into scales (4) after a short calculation the solution is:

$$\rho \cdot \bar{v} \cdot \Delta V = \frac{C_p}{C_\rho C_v^2} \cdot p \cdot \Delta A + \frac{C_\tau}{C_\rho C_v^2} \cdot \bar{\tau} \cdot \Delta A + C_L \cdot \frac{C_f}{C_\rho C_v^2} \cdot \bar{f} \cdot \Delta V \quad (7)$$

where relation (8) was taken into consideration. Comparing (3) with the above mentioned scales it can be seen that the equations of scales are similar even if the so-called criteria equations below are existed:

$$\frac{C_p}{C_\rho C_v^2} = 1, \quad \frac{C_\tau}{C_\rho C_v^2} = 1, \quad \frac{C_f}{C_\rho C_v^2} = 1 \quad (8)$$

In the following the conditions of similarity of material equations are studied.

2.1. Similarity numbers of power-type fluid

It is known that the equation of material in the case of this type of fluid is:

$$\tau = KD^m \quad (9)$$

where D is the shearing speed and m is the flow exponent. According to the definition of analogy the equations below must be the same:

$$\tau = KD^m, \quad \tau' = K' D'^m \quad (10)$$

Proportion of C_k K and K' is:

$$K' = C_k K \quad (11)$$

Considering definition of D and relations (5) the solution from the second equation of relation (10) is:

$$C_\tau = C_k \left(\frac{C_v}{C_L} \right)^m \quad (12)$$

Substituting relation (12) for equations (8) the following equations of criteria can be determined:

$$\frac{C_p}{C_\rho C_v^2} = 1, \quad \frac{C_k}{C_\rho C_v^{2-m} C_L^m} = 1, \quad C_L \frac{C_f}{C_\rho C_v^2} = 1 \quad (13)$$

These relations and geometrical similarity together give the condition of flow similarity. From the above mentioned equations with using relation (5) an another definition for analogy theory is given:

$$Eu := \frac{p}{\rho v^2} = \frac{p'}{\rho' v'^2}, \quad Re := \frac{\rho v^{2-m} L^m}{K} = \frac{\rho' v'^{2-m} L'^m}{K'}, \quad (14)$$

$$Fr := v \sqrt{\frac{\rho}{f L}} = v' \sqrt{\frac{\rho'}{f' L'}}$$

where Eu is the Euler-, Re is the Reynolds- and Fr is the Froude- number. Consequently the condition of flow similarity is that the above mentioned similarity numbers composed by the flow-geometrical and physical quantities of real and reduced scale model must be the same.

2.2. Similarity numbers of Bingham-type fluid

The equation of material in the case of this type of fluid is:

$$\tau = \tau_f + \eta D \quad (15)$$

where τ_f is the flow stress and η is the *plastic viscosity*. In consequence of similarity the equations below must be the same:

$$\tau = \tau_f + \eta D, \quad \tau' = \tau'_f + \eta' D' \quad (16)$$

Suppose that η' is:

$$\eta' = C_\eta \eta \quad (17)$$

Considering definition of D and relations (5) now the solution from the second equation of relation (16) is:

$$\frac{C_\tau C_L}{C_v C_\eta} = 1, \quad \frac{C_{\tau_f} C_L}{C_v C_\eta} = 1 \quad (18)$$

Relations (8) from the impulse scales will also take into consideration. With a similar calculation the condition of flow similarity can be described in the following way:

$$Eu := \frac{p}{\rho v^2} = \frac{p'}{\rho' v'^2}, \quad Re := \frac{\rho v L}{\eta} = \frac{\rho' v' L'}{\eta'}, \quad (19)$$

$$Fr := v \sqrt{\frac{\rho}{f L}} = v' \sqrt{\frac{\rho'}{f' L'}}, \quad He := \frac{\rho \tau_f L^2}{\eta^2} = \frac{\rho' \tau'_f L'^2}{\eta'^2}$$

So the so-called He Hedström-number is contributed to the previously mentioned similarity numbers.

3. Applying the theory

Because the fluid's equation of motion establishes relations among its physical features therefore the similarity numbers are not independent on each other. Ge is the geometrical similarity number. In the case of tube for example $Ge := \frac{L}{d}$, where L is the length and d is the diameter of the tube so that the function relations below can be determined:

$$Eu := F(Ge, m, Re, Fr), \quad Eu := F(Ge, Re, Fr, He) \quad (20)$$

where the first function is related to the power-type and the second is to the Bingham-type fluid. Exact relations of these functions are defined in the following cases.

3.1. Darcy-Weissbach's resistance formula for tube and its armatures

In the case of tube the Eu -number is the linear function of tube length in function (20). So:

$$Eu := \frac{L}{d} G(m, Re, Fr), \quad Eu := \frac{L}{d} (Re, Fr, He) \quad (21)$$

The two typical quantities are: the pressure between the ends of the tube and the average speed. In this case on the basis of equation (14) and (19) the above mentioned equations can be converted into the following equations:

$$\frac{\Delta p}{L} := \lambda(m, Re, Fr) \frac{1}{d} \frac{\rho v_a^2}{2}, \quad \frac{\Delta p}{L} := \lambda(Re, Fr, He) \frac{1}{d} \frac{\rho v_a^2}{2} \quad (22)$$

where $\lambda(m, Re, Fr)$ and $\lambda(Re, Fr, He)$ are the tube friction factors of structured fluid. In the case when the fluid fills up the cross-section of the tube the Fr -number cannot be taken into consideration it means that the tube friction factor is not dependent on Fr -number. The situation is the same in such a channel' flow when the free surface of the fluid is not billowing. In the event of laminar flow and power-type fluid the tube friction factor is the following:

$$\lambda := \frac{6[2(3m+1)]^m}{m} \frac{K}{\rho D^m v_a^{2-m}} = \frac{m}{Re} \quad (22.a)$$

In the case of $\eta = K$, $m = 1$ the above mentioned formula is inserted into Blasius's tube friction factor of Newton fluid's laminar flow:

$$\lambda := \frac{64}{Re} \quad (22.b)$$

In the case of turbulent flow the formula of the power-type structured fluid is the following:

$$\lambda := 0.316 Re^{-0.25}, \quad Re \leq 13000 \quad (22.c)$$

In the case of $\eta = K$, $m = 1$ this formula is inserted into the phrase of tube friction factor related to the tube with plain wall of Newton fluid's turbulent flow:

$$\lambda := \frac{0.316}{Re^4} \quad (22.d)$$

In the event of laminar flow of Bingham-typed structured fluid the tube friction factor's dependence on Reynolds and Hedström number can be determined from the relation below:

$$\frac{1}{Re} = \frac{\lambda}{64} - \frac{1}{6} \frac{He}{Re^2} + \frac{64}{3\lambda^3} \left(\frac{He}{Re^2} \right)^4 \quad (22.e)$$

In the case of tube armatures the dependence on Ge number is optional so it is not taken into consideration. So from relation (21) the solution is:

$$\Delta p := \lambda(Ge, m, Re, Fr) \frac{\rho v_a^2}{2}$$

$$\Delta p := \lambda(Ge, Re, Fr, He) \frac{\rho v_a^2}{2} \quad (23)$$

Dependence on Fr number is the same as previously mentioned.

3.2. Mechanical impeller

In the event of impellers instead of speed the n RPM and instead of pressure the P shaft power is practically applied in the Eu number. With simple calculation

$$Eu = \frac{P}{\rho n^3 d_j^5}$$

can be defined, which is called power number in the case of impellers and is signed with C . In the phrase d_j is the diameter of the rotor. Herewith relations (20) is transformed to the following equations:

$$C := \frac{P}{\rho n^3 d_j^5} = f(Ge, m, Re, Fr)$$

$$C := \frac{P}{\rho n^3 d_j^5} = f(Ge, Re, Fr, He) \quad (24)$$

which can be determined for example with the help of reduced scale model experiments. Figure 2 shows such an experimentally determined diagram joint. In the case when the free surface of the fluid is not billowing in the mixer tank the Fr

number is not existed so the power is not dependent on Fr number. This phenomenon is typical in the case of temporary and turbulent mixing conditions (curve 2 of Figure 2). Though billows reduce the power number it damages the quality of mixing. Billows can be realized with a damper plates protruding into the fluid at right angles to the free surface of fluid.

4. Results and conclusions

It has been determined that with the help of analogy theory method the analogy criteria of structured agricultural fluids can be defined in the case of the two most important models. These analogy numbers play a significant role in experiment planning since with the help of these the numbers of changing parameters can be drastically reduced. With further theoretical considerations now the reduced and experimentally determined function relation can be transformed into a simple, well-handled form. It has been determined that the Darcy-Weissbach's resistance rule worked out for Newton medium can also be applied in the case of structured fluids. Tube and amature friction factor of Darcy-Weissbach's resistance rule have been determined in the function of Ge, Re, Fr, He criteria numbers. The power number of the impeller as the function of Ge, Re, Fr, He criteria numbers has also been defined.

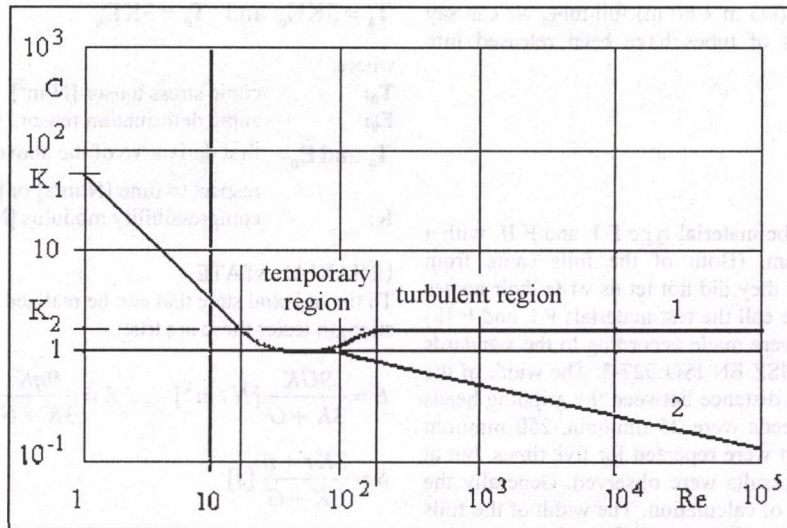
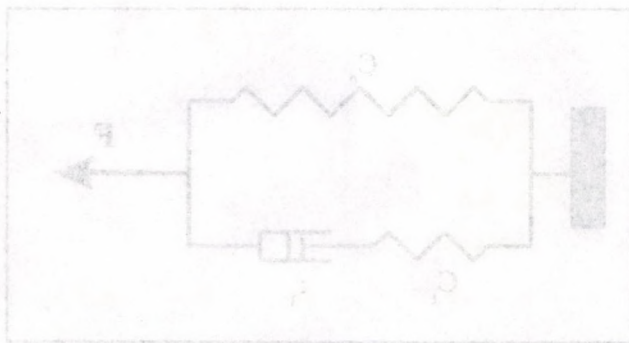

Figure 2 Power number in the function of Reynolds number



MECHANICAL FEATURES OF AGRICULTURAL PACKAGING FOILS

A. Csátár – Z. Bellus – L. Csorba

Hungarian Institute of Agricultural Engineering, Gödöllő

1. Introduction

They use tubular films for preservation and storing for 8-10 years in Hungary. But the examinations in connection with the method did not study the strength and rheological features of the foil as an individual material.

New challenges (high quality end-product, environment protection, new designs, etc.) appear in the Hungarian forage experience that must aqit the EU requirements in the future. This makes inevitable to change the obsolescent technologies in our country, that are operating with many losses and loading the environment. The following data prove the spreading of the new method: Preservation and storing in tubular films started to penetrate in 1997-98 and now we can say that it is used in more than 35 farms. The application was the largest in 2003 when 42-43 000 tons of sugar-beet chips, around 40 000 tons of hay silage and about 12-13 000 tons of wet corn grit, corn silo, corn cob grit and other agricultural secondary products (corn-peel, marcs, screenings of wet cereals, etc.) has been filled into foil tubes. Considering that about 200 tons of fodder can be filled in a commonly used (Ø3 m x 60 m) foil tube, we can say that about 450-480 pieces of tubes have been released into commerce.

2. Material and method

2.1 Tensile strength test

For testing we used foil tube material type F I. and F II. with a thickness of 0.23-0.24 mm. (Both of the foils came from different manufacturer, but they did not let us write their names in this study, that's why we call the test materials F I. and F II.) The tensile strength tests were made according to the standards MSZ EN ISO 527-1 and MSZ EN ISO 527-3. The width of the specimen was 25 mm. The distance between the gripping heads was 100 mm. The test speeds were 25 mm/min, 250 mm/min and 500 mm/min. Each test were repeated for five times, but at the evaluation only three results were observed. Generally the two extremes were left out of calculation. The width of the foils were measured by a Mitutoyo 541 type digital thickness gauge. Thickness was measured on each sample at minimum three different places and the average of the measurements were accepted as average foil thickness. The strength was determined

by the $\sigma = \frac{F}{A}$ formula, where:

σ : strength of the foil [MPa]

F: force that is needed for the rip of the foil [N]

A: section of the foil at start [mm²]

Farther the rated tensile deformation was determined by using

the $\varepsilon_r(\%) = \frac{\Delta L}{L} * 100$ formula

where:

ε_r : rated tensile deformation of the foil at the moment of ripping [%]

ΔL : growth of the distance between the gripping heads [mm]

L: original distance between the gripping heads at 2 N prestress [mm]

Flowing strength was determined by using the $\sigma_f = \frac{F_f}{A}$

formula, where:

σ_f : flow limit of the foil [MPa]

F_f : force that is needed for the flowing of the foil [N]

A: section of the foil at start [mm²]

Tensile strength tests were made on an INSTRON 5581 type test machine.

2.2 Rheological test

The simplest linear material model that can follow the rheological features (creeping, relaxation) is the Poynting-Thomson model (figure 1.). It's differential equation is the following:

$$\mathbf{T} = 2GE + 2\eta\dot{\mathbf{E}} - \tau\ddot{\mathbf{T}} \quad (1)$$

where:

T: deviatoric stress [N/m²]

E: deformation deviator tensor [1]

$\dot{\mathbf{T}}$ and $\dot{\mathbf{E}}$: first derivative of the above mentioned with respect to time [N/m²s] or [1/s]

G: modulus of elasticity in shear [N/m²]

η : coefficient of viscosity [Ns/m²]

τ : time of relaxation [s]

furthermore:

$$\mathbf{T}_0 = 3KE_0 \quad \text{and} \quad \dot{\mathbf{T}}_0 = 3K\dot{\mathbf{E}}_0 \quad (2)$$

where:

\mathbf{T}_0 : cubic stress tensor [N/m²]

\mathbf{E}_0 : cubic deformation tensor [1]

$\dot{\mathbf{T}}_0$ and $\dot{\mathbf{E}}_0$: first derivative of the above mentioned with respect to time [N/m²s] or [1/s]

K: compressibility modulus [N/m²]

UNIAXIAL STATE

To the uniaxial state that can be realized with the tensile-strength tester these are true:

$$E = \frac{9GK}{3K + G} [N/m^2] \quad , \quad \lambda = \frac{9\eta K}{3K + G} [Ns/m^2],$$

$$\vartheta = \frac{3K\tau + \eta}{3K + G} [s] \quad (3)$$

where the equation of the material is:

$$\sigma = E\varepsilon + \lambda\dot{\varepsilon} - \vartheta\ddot{\sigma} \quad (4)$$

The quantities E , λ , ϑ in the equations (3) are characteristics (constants) that determine the mechanical behaviour of the material. The mechanical model of the Poynting-Thomson sample built from springs and dampings (figure 1.).

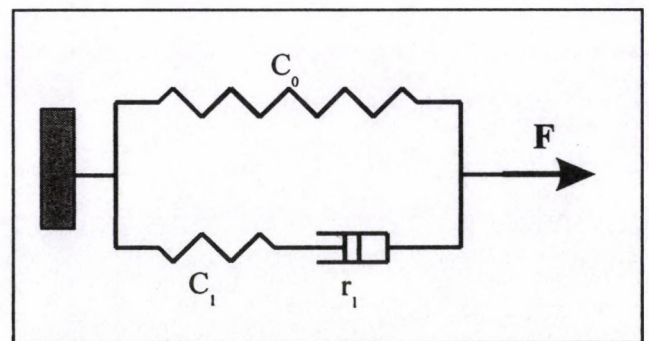

Figure 1 Mechanical model of PoyntingThomson material equation

Connection between the model and the constants of the differential equation:

$$E = \frac{1}{C_0}; \quad \lambda = r_1 \left(1 + \frac{C_1}{C_0}\right); \quad \vartheta = r_1 * C_1$$

Stress σ equals force F and the elongation ϵ stands for the displacement of the force F .

The aim of the uniaxial rheological measurements is to determine the parameters E, λ, ϑ (material characteristics) that describe mechanical behaviour.

Burger's model was applied (figure 2.) instead of the Poynting-Thomson model, because the creep curve was not converging to the surface tangent (figure 4.). Applying Burger's model increased the number of material characteristics with an additional element (λ_A).

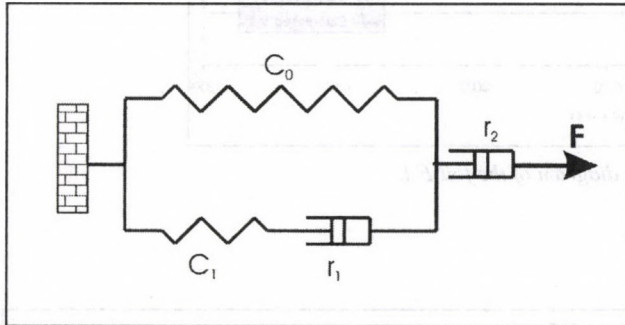

Figure 2 Burger's model

Comparison based classification can be done using the parameters (constants) $E, \lambda, \lambda_A, \vartheta$ derived by the uniaxial examinations. A new foil material's expected parameters can be estimated from the correlation between the experiences of application and measured characteristics. Relationship between ageing and the changes of the parameters is also an important knowledge.

3. Results

Results of tensile strength tests

Mechanical properties of the two different foils can be seen in table 1. The test speed was 500 mm/min.

In the next figure the tensile-test diagram of the foil F I. can be seen at test speed 500 mm/min.

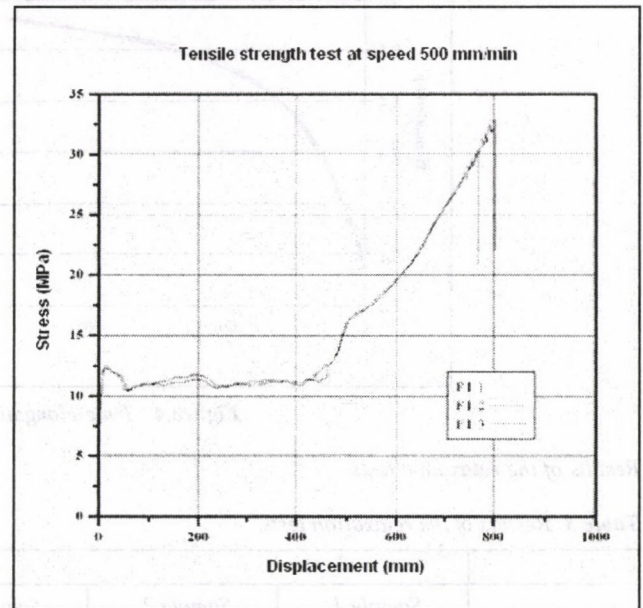

Figure 3 Tensile-test diagram of foil F I.

These data clearly show that the mechanical properties of foil F I. are better than the mechanical properties of foil F II., because the maximum tensile stress of foil F I. is 30 MPa, while the foil F II. has a maximum tensile stress about 25 MPa. Elongation and flow limit values were nearly the same. Results were similar at the other two test speeds too.

Table 1 Mechanical properties at test speed 500 mm/min

Test speed = 500 mm/min				
F I.				
	Sample 1.	Sample 2.	Sample 3.	Average
Tensile strength [MPa]	29,51	29,24	31,85	30,20
Rated elongation [%]	766,85	768,87	802,17	779,3
Flow limit [MPa]	10,53	10,48	10,41	10,47
F II.				
	Sample 1.	Sample 2.	Sample 3.	Average
Tensile strength [MPa]	21,43	26,81	27,68	25,31
Rated elongation [%]	703,69	800,95	837,7	780,78
Flow limit [MPa]	9,76	9,8	9,7	9,76

Table 2 Results of the creep tests

F I.						
	Sample 1.	Sample 2.	Sample 3.	Sample 4.	Sample 5.	Average
E [MPa]	18,45	14,82	17,167	16,45	17,21	16,82
λ [Ns/m ²]	16385,6	11030,5	15001,8	13968,5	14345,8	14146,4
λ_A [Ns/m ²]	286322,9	352867,8	604614,2	40568,7	42387,5	265352,2
F II.						
	Sample 1.	Sample 2.	Sample 3.	Sample 4.	Sample 5.	Average
E [MPa]	16,66	15,13	16,61	15,96	16,32	16,13
λ [Ns/m ²]	24915,6	38847,1	29903,4	28759,6	34158,89	31316,9
λ_A [Ns/m ²]	306851,2	746445,1	468466,4	507254,1	576487,4	521100,8

Results of the creep tests

The figure 4 shows the time-elongation diagram of the foil F I.

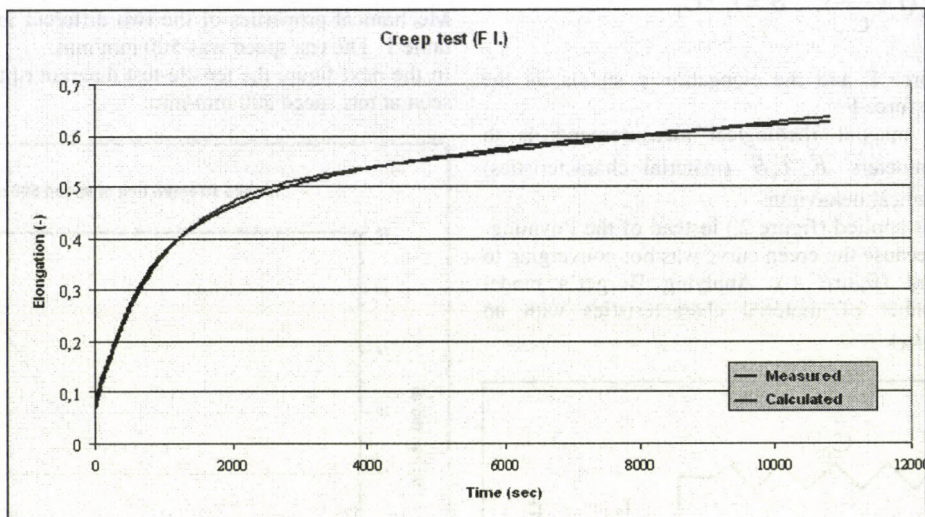

Figure 4 Time-elongation diagram of the foil F I.

Results of the relaxation tests

Table 3 Results of the relaxation tests

	F I.					
	Sample 1.	Sample 2.	Sample 3.	Sample 4.	Sample 5.	Average
E [MPa]	65,95	67,49	70,35	69,58	65,23	67,72
ϑ [s]	207,41	222,89	305,63	217,99	273,56	245,50
	F II.					
	Sample 1.	Sample 2.	Sample 3.	Sample 4.	Sample 5.	Average
E [MPa]	70,24	116,58	31,08	82,88	59,52	72,06
ϑ [s]	454,67	526,56	201,18	536,51	385,319	420,85

The figure 5 shows the stress-time diagram of the foil F I.

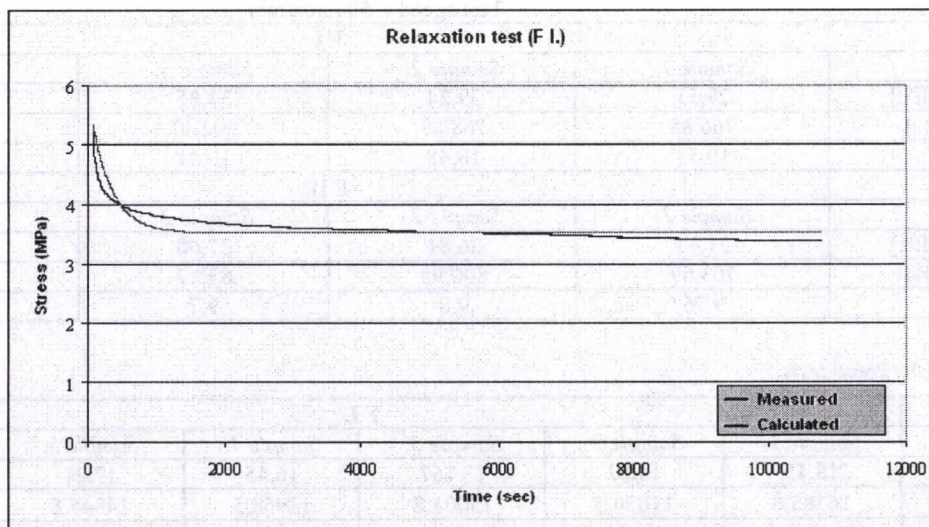

Figure 5 Stress-time diagram of the foil F I.

References

- [1] Csatár A. – Bellus Z. – Darányi J.: Mezőgazdasági fóliák alkalmazási lehetőségei. Aranykorona, 2002. II. évfolyam 10.szám
- [2] Csatár A. – Bellus Z.: Mezőgazdasági takarófóliák mechanikai vizsgálata. MTA-AMB XXVII. Kutatási és fejlesztési tanácskozás, Gödöllő 2003. január 21-22.

HEAT TREATMENT OF THE MIXED FODDER

J. Csermely – M. Herdovics – Gy. Komka
Hungarian Institute of Agricultural Engineering, Gödöllő

Aims of the research

Aims of the research works are to summarize the results of the technical-technological and energetical examinations that have gained during expanding and hygienization of mixed fodder, demonstrate the feeding characteristics and by means of economical model calculations help the extending application of the results in practice.

Method and circumstances

Since the middle of the 90-ies the most up-to-date heat treating technologies, eg. expanding and hygienization were integral parts of the technological reconstructions of the fodder-mixing plants of 10-20 t/h capacities. Aim of the hygienization is to make better the microbiological state of the mixed fodder, while in addition to this, expanding results better feed conversion efficiency and yields the improvement of the physical quality of pellets. Expanders and hygienizers with 5-40 t/h wide range of output can be fitted flexibly in different technologies of fodder-mixing plants. The present study summarizes the main results of the examinations concerning these heat treatments. Figure 1. shows the flow diagram of the fodder-mixing plant.

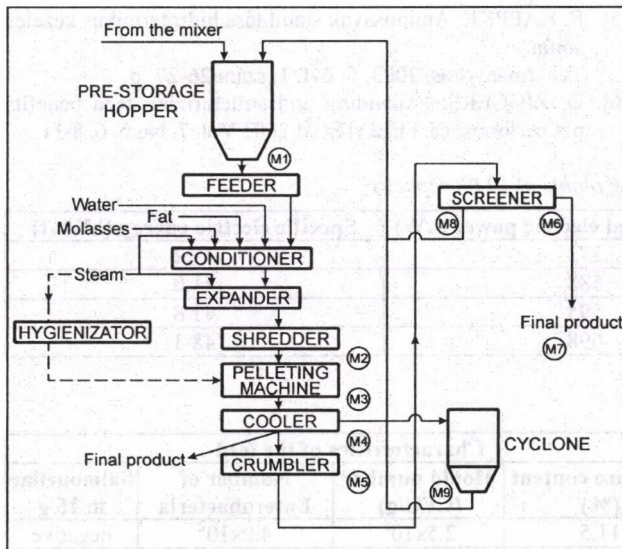

Figure 1 Technologies based on expander and hygienizer
(M = measuring sites)

Examined technologies

Hygienizer is a conditioner of long time, serving annihilation of micro-organisms of the coarse meal of mixed-fodder that has to install after the conditioner auger of the pelleting machine. The 75-85°C temperature of the coarse meal, pre-heated by steam, has to held on this level while passing through the conditioner auger. Holding on the required temperature is ensured by steam flow into the double-wall tube of the equipment (0.5-10 bar; 110-118°C). The feeder of the mixed coarse meal (crumbler) is installed following the hygienizer. This crumbler ensures a close uniform grain size and flow of material. The press feeder also has a heat-insulating cover.

In order to moderate heat losses the heat-insulating cover is heated by steam. Duration of heat treatment is 4-5 sec (see Fig. 2). As a result of the shear force, during the extrusion, cell wall and starch grid of the fodder components are shattered and for this reason digestibility will become better and yields a better

feed utilization. Before pelleting expanded fodder is chopped. Construction of the equipment makes possible to eliminate the pressure and in this way fodder can be pelleted without heat treatment.

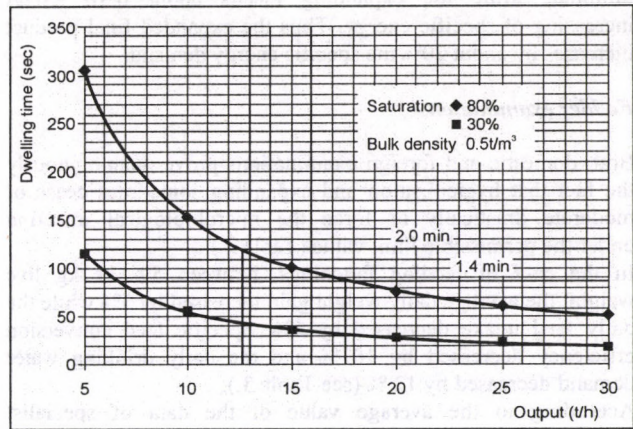

Figure 2 Nominal output of the CPM 24 hygienizer

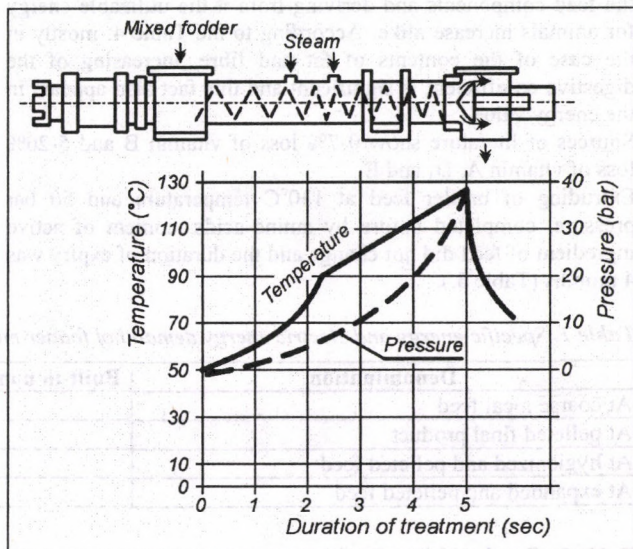

Figure 3 Schematic flow diagram of the expanding process

Results

Relation of physical and mechanical characteristics

Rate of chippings, depending of the maize proportion, decreases if expanding is followed by pelleting. PD index of the expanded and pelleted end-product as well as its hardness linearly increase by increasing the expander pressure. This results a better quality of pellet. (Fig 4;5)

Relationship between the shredding index and the crumbling force at a constant expander pressure and diameter of matrix hole (Ø5 mm) as well as changing composition can be described well by the function of $y = 0.0988x + 80.79$. In this case $R^2 = 0.8206$. These results mean that the hand-operated crumbling force measuring device can give accurate informations for the practice, making possible the right technological corrections. (Fig. 6.)

Energetical characteristics

On the basis of the technological flow diagram (see Fig.1), specific energy consumptions were compared among final products, treated in different ways at a mixed-fodder line with 100 t/h capacity.

The specific energy demand is near twofold at the final product of coarse meal and pelleted feed.

Pelleting requires about 10-12 kWh/t from the 41.0 kWh/t specific energy demand. Energy surplus of the hygienization is minimal, while the expanding means about 6-10 kWh/t increasing of specific energy. Thus the expanded final product increases by about 20% the specific energy demand.

Fodder examinations

Both domestic and foreign examinations prove unambiguously the fact that hygienization and expanding sometimes cease or moderate drastically or force the microbiological infection under the permissible limit value (Table 2.)

In the case of feeding fattenings, between 59-111 kg live weight, the average daily weight gain increased by 5% while the daily feed intake decreased by 6%. Specific feed conversion efficiency decreased by 10 % and the daily drinking water demand decreased by 12 % (see Table 3.).

According to the average value of the data of specialist literature, the feed conversion efficiency improves by 4-7%. Reasons of this fact are, among others, that the digestibility of the feed components and deriving from it the utilizable energy for animals increase alike. According to the Table 4. mostly in the case of the contents of fat and fibre, increasing of the digestive co-efficient is significant and this fact also appears in the energy value.

Sources of literature show 0-7% loss of vitamin B and 5-20% loss of vitamin A, D₃ and E.

Extruding of broiler feed at 130°C temperature and 50 bar pressure, completed before by amino-acids, content of active ingredient of feed did not change and the duration of expiry was 4 months (Table 5.).

Operational costs of heat treatment

Data of model calculations of a fodder – mixing plant of 10 t/h capacity, running 2,500 and 5,000 hours per year, and found on data of facts, can be seen in Table 6. As it can be seen hygienization hardly increases the operational costs while at expanding increasing of cost, depending on the yearly utilization, varies between 17-20%. Specific construction costs of the engineering technology increases from 18.5 million HUF/t to 20.8 and 22.8 million HUF/t. This means 11% and 19% increasing in the costs of investment.

References

- [1] CSERMELY J. - HERDOVICS M. - KOMKA Gy.: Hőkezelési technológiák műszaki-energetikai elemzése. MTA-AMB 1991. II. kötet 190-194. p.
- [2] CSERMELY J. - BELLUS Z. - HERDOVICS M.- KOMKA Gy.: Az expandált keveréktakarmány-gyártás vizsgálati eredményei. MTA-AMB 1996. I. kötet 109-114. p.
- [3] CSERMELY J. - KOMKA Gy.: Technológiai jellemzők befolyása a takarmánypellet fizikai állapotára. Takarmányozás, 2000. 3. évf. 2. szám 25-28. p.
- [4] J. CSERMELY - M. HERDOVICS - Gy. KOMKA - Z. BELLUS- I. PAZSICZKI: Strength characteristics of fodder pellets. 4 th CHOPS Budapest, 2003. Volume 1. 487-491. p.
- [5] F. KAPPE: Aminosavak stabilitása hidrotérmikus kezelés során. Takarmányozás, 2003. 6. évf. 1. szám 26-27. p.
- [6] D. ZIGGERS: Expanding and structurizing feed benefits pig performance. FEEDTECH 2003 Vol. 7. Num. 6. 8-11. p.

Table 1 Specific energy and electric energy demand of fodder mixing plants of 10 t/h capacity

Denomination	Built-in nominal electric power (kW)	Specific electric energy (kWh/t)
At coarse meal feed	273	19.2
At pelleted final product	588	41.0
At hygienized and pelleted feed	595	41.8
At expanded and pelleted feed	698	48.3

Table 2 Results of the microbiologic tests

Denomination of the feed	Site of sampling	Number of the examination record	Characteristics of the feed			
			Moisture content (%)	Mould number (CFU/g)	Number of Enterobacteria	Salmonellae in 25 g
Starter for broilers	After mixer	01-98-0981	11.5	2.5x10 ³	4.0x10 ²	negative
	After hygienizator	01-98-0982	12.3	1.0x10 ²	1.0x10 ²	negative
Intensive feed for broilers	After mixer	01-98-0985	11.6	6.0x10 ³	1.6x10 ³	negative
	After hygienizator	01-98-0986	12.7	1.0x10 ²	1.0x10 ²	negative
Piglets I.	After mixer	01-98-1056	9.5	2.7x10 ³	1.0x10 ²	negative
	After hygienizator	01-98-1057	10.1	1.0x10 ²	1.0x10 ²	negative

Table 3. Effect expanding on the feeding of fattenings (Hancock et.al 2000)

Feeding characteristics	Coarse meal	Pelleted feed	Expanded and pelleted feed
Daily weight gain (g)	909	954	950
Feed consumption (kg/day)	2.71	2.72	2.55
Specific feed conversion efficiency (kg/kg)	3.01	2.86	2.72
Daily drinking water consumption (dm ³ /day)	6.7	6.7	5.9

Table 4 Digestibility and energetic value of broiler feed treated by different methods (Armstrong-1993)

Treating methods	Organic matter	Digestibility (%)				Unit (MJ/kg)
		Protein	Fat	Starch	Fibre	
Pelleting	68.6	78.5	70.6	97.8	8.2	11.71
Expanding and pelleting	70.2	77.2	82.3	98.9	16.1	12.22
Expanding	69.8	79.9	82.9	98.4	17.9	12.21

Table 5 Stability of amino acids following expanding and pelleting (F.Käppke 2002)

Denomination	Original state	After expanding	After expanding and pelleting
DL-methionine (%)	0.20	0.21	0.19
Biolys® 60 (%)	0.22	0.23	0.22
L-treonine (%)	0.06	0.06	0.05

Table 6 Costs elements and operational costs of heat treating technologies of a fodder-mixing plant wit 10 t/h capacity

Kind of fodder	Hours of the shifts (hours/year)	Cost of the engineering technology (thousand HUF)	Total costs* (thousand HUF)	Operational costs	
				(Ft/hour)	(Ft/t)
Coarse meal	2,500	155,500	34,586	13,834	922
	5,000		54,212	10,842	723
Pelleted feed	2,500	185,000	41,898	16,760	1,676
	5,000		65,759	13,152	1,315
Hygienized and pelleted feed	2,500	208,000	44,511	17,804	1,780
	5,000		68,694	13,738	1,334
Expanded and pelleted feed	2,500	228,000	50,519	20,207	2,021
	5,000		81,808	16,362	1,636

Notice: *Total costs, including wages, amortization, costs of material, costs of repair and maintenance; rates and taxes.

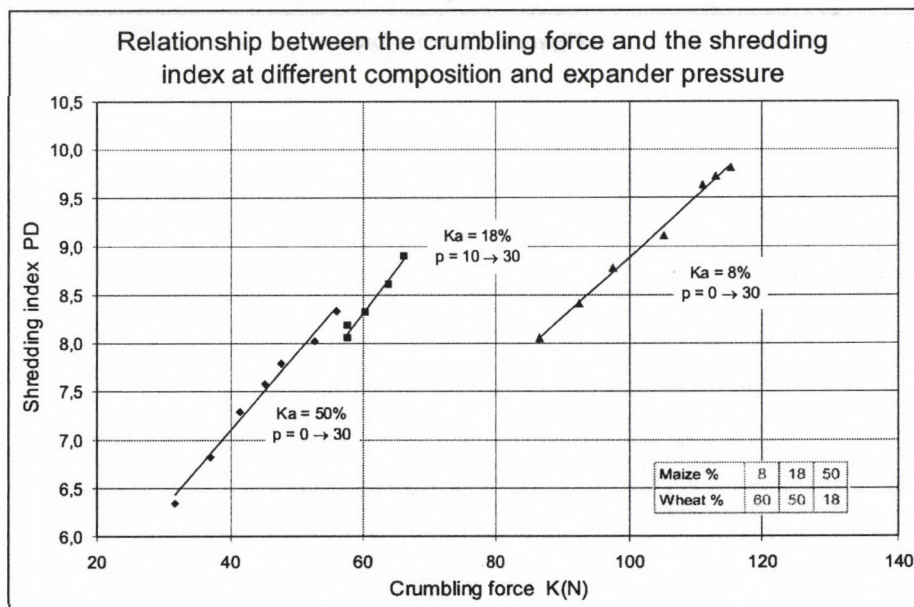

Figure 4 Crumbling force

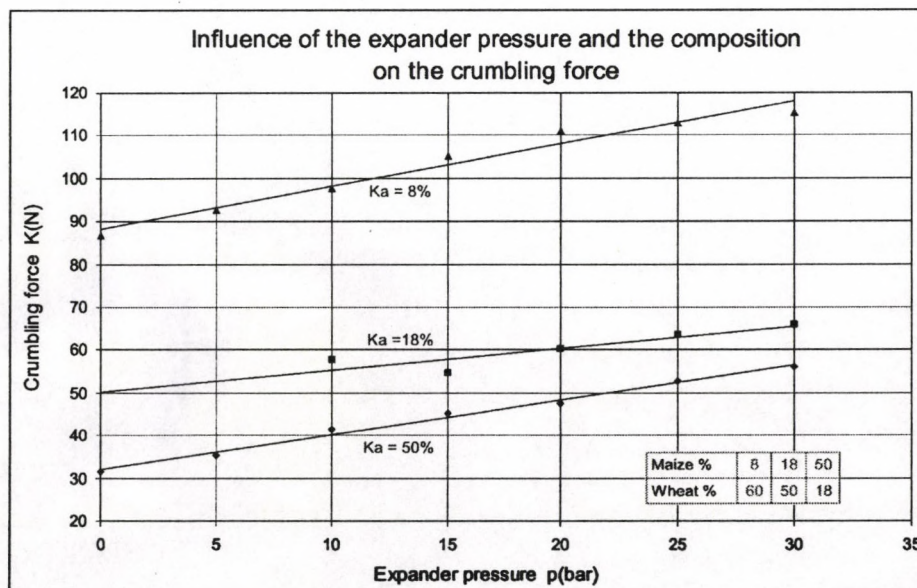

Figure 5 Pressure of expanding

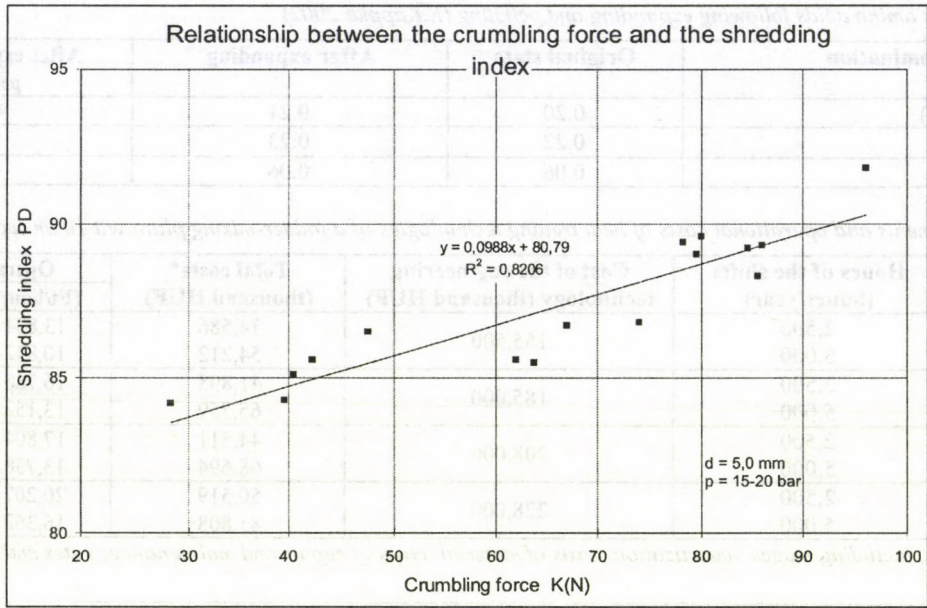

Figure 6 Crumbig force

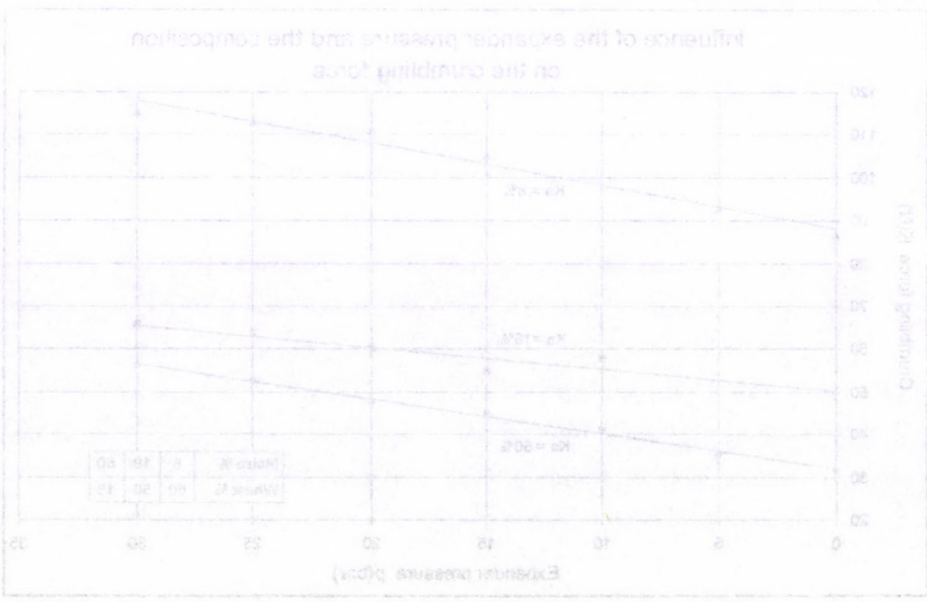

Figure 7 Pressure of expanding

POSSIBILITIES OF REDUCING EMISSIONAL ENVIRONMENTAL LOAD IN PIG HOUSING

I. Pazsiczki¹ – W. Berg² – L. Ducza³

¹Hungarian Institute of Agricultural Engineering, Gödöllő

²Institute of Agricultural Engineering Bornim (ATB)

³TSF College of Agricultural Sciences, Mezőtúr

1. Aim of the research

Examination of main gases (NH₃, CO₂, CH₄) emitted from manure in animal farms under laboratory conditions have been done. Aim of this was to investigate and work out different emission reduction technologies. The rate between control and trials were measured at laboratory size investigations and the practical value of different techniques were studied.

2. Introduction

Nearly each of the direct or indirect influential factors of emission were studied in the past decades. Most important ones maybe the composition of manure and some features of surroundings as temperature, air exchange, degree of acid (pH value). The composition of manure from the point of examination of emission reduction techniques can be considered as equivalent during the research or it is examined from biological aspect. Features of surroundings and effect of litter and additives were measured and studied in many times.

A complex effect of temperature can be found at gas production from the stand point of emission. Higher temperature evokes higher biological activity but over this it produces higher emission with the indirect effects of higher air-exchange rate (D.D. Schulte [6]). There is a positive correlation between air exchange rate (volume of fresh air) and odor emission revealed by Oldenburg and Mannebeck in 1987. The degree of emission reduction by cooling slurry was found 44-75 % by dutch researchers that is considerable result but economical aspect of the technique is a controversial thing (G.M den Brok et. al [1]). To change the pH value of slurry to the direction of acidity is also a well studied technique. Dutch researchers reached 42-45 %

emission reduction by adding organic acid (J.G.L. Hendriks et. al [3]). There were researches of adding sulphur acid in Denmark and 50 % emission reduction was reached (Pedersen [5]). Berg and Hörmig in 2000 have found that lowering pH value reduce not only ammonia but also nitrous oxid and methan emission. Belgian researchers who examined emission features of deep littered pig husbandry have said that sawdust is better littermaterial than straw and using of bedding additives have reduced emission. They think it as a problem that compounds and working formulas of additives obtainable in commerce are not known and there is no scientific certainty of their effect (B.Nicks et. al [4]).

Twelve different slurry covering materials (from chopped straw through polyethylene net to light rock) have been examined by American reaserchers in containers digged into ground. Their final conclusion was that each materials have some kind of emission reduction effect but some of them have a short lifetime (D.S.Bundy et. al [2]). English researchers also with surface covering reached 68 % ammonia emission reduction in working facilities and 75-80 % one in laboratory circumstances (A.G.Williams et. al [7])

3. Material and Method

Gas concentrations emitting from manure can be measured in our laboratory in containers with a maximum capacity of 90 litre. During measurement fresh air from outside have been flowed through the container above manure surface. Volume of air goes into the closed containers have been set and measured by rotameter. Air goes into the containers at four points and after rinsing the space above manure surface leaves it through the middle of lid. Gas concentrations of air going in and out have been measured by the measuring equipment (INNOVA 1312 Multi-Gas Monitor) that takes sample with its inner air pump. The containers have not been closed similarly to practice in our present measuring method (open chamber method) however for commulating gases they have been closed for ten minutes before and during the measurments. (as shown in Fig. 1) Exact emission values can not be quantified with this method

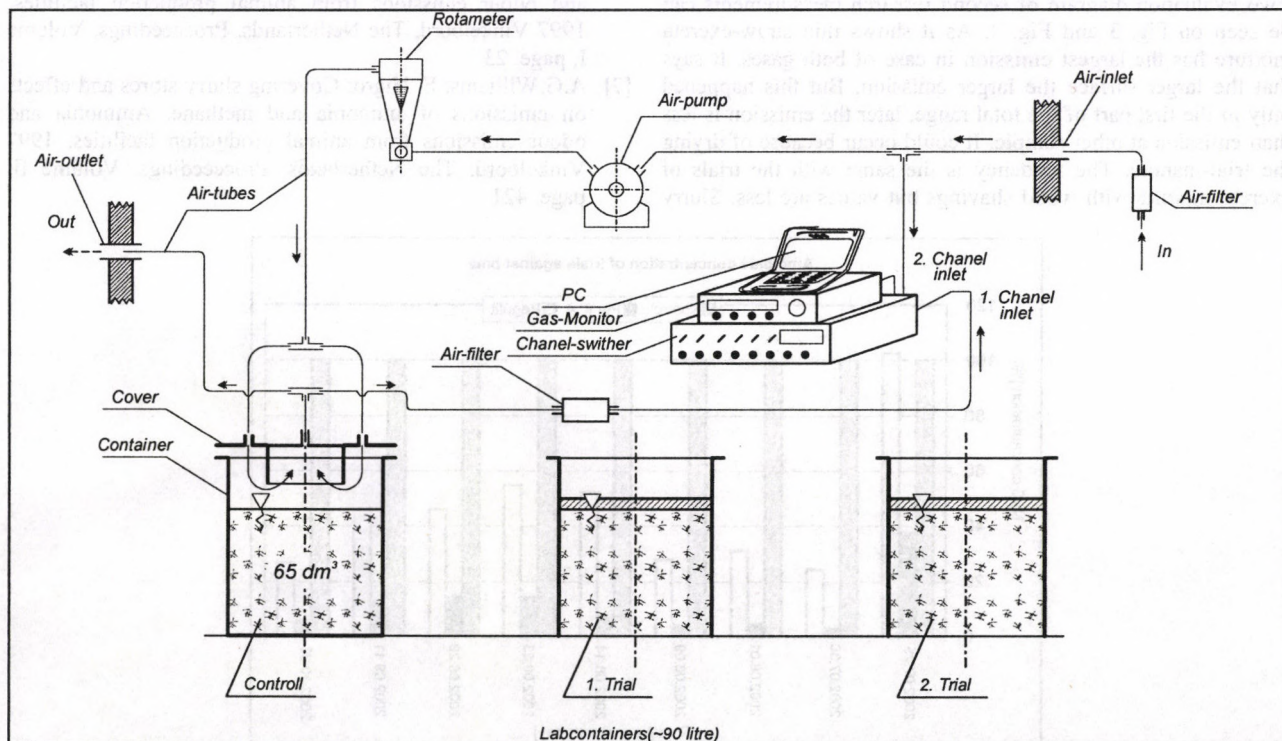

Figure 1 Drawing of measurement circle

Table 1 Dry Matter content of samples

Sample	I	II	III	IV	V	VI	VII	VIII
Name	Thin mix. straw	Consistent mix. straw	Thin mix. wood-shavings	Consistent mix. wood-shavings	Thin slurry	Thick slurry	Covering by wood-shavings	Covering by straw
Dry matter content [%]	27,9	24,8	26,3	24,5	3	5,6	3	3

even the gas flow of inflowing and escaping gases are known but this is not an aim of measurement. We wanted to measure the difference and rate between control and trial samples kept among same circumstances. Two series of measurements have been carried out among laboratory circumstances. One for studying surface-covering emission reduction method and one for comparing different composition of pig manure.

4. Results

Three different manure – excrement mixed with woodshavings (1) and straw (2), slurry (3) – with two mixing rate have been investigated. It means 6 samples of mixtures plus two surface-covering – with covering materials of straw (1) and woodshavings (2) - have been added to them. It means 8 samples altogether with the volume of 60 litres each. Their dry matter contents are shown in Table 1. The chains of measurement have been started at the following day of mixing and lasted 11 days with 4 measuring occasions.

5. Evaluation of results

An evaluation diagram of first research measurements can be seen on Fig. 2. Effect of slurry surface-covering to ammonia emission can be followed on this diagram. Gas concentration of control sample means 100 % and trials are compared to it. Effect of covering is very considerable, the emission reduction values are from 45% till 97 %. The material Pegülit (mixture of perlit and lactic acid) gave the best reduction effect. A technique usable in practice can be developed by this results and materials.

Two evaluation diagram of second research measurements can be seen on Fig. 3 and Fig. 4. As it shows thin straw-excreta mixture has the largest emission in case of both gases. It says that the larger surface the larger emission. But this happened only in the first part of the total range, later the emission is less than emission at other sample. It could occur because of drying the trial-manure. The tendency is the same with the trials of excreta mixture with wood shavings but values are less. Slurry

surface-covering with straw and with wood shavings show emission reduction effect but the extent is very small. Comparing the two material there is no difference between them at CO₂ and there is a little difference at NH₃.

References

- [1] G.M den Brok; N. Verdoes: Slurry cooling to reduce ammonia emission from pig houses. Ammonia and odour emissions from animal production facilities, 1997 Vinkeloord, The Netherlands, Proceedings, Volume II, page. 441
- [2] D.S. Bundy; X. Li; J.Zhu; S.J. Hoff: Malodour abatement by different covering materials. Ammonia and odour emissions from animal production facilities, 1997 Vinkeloord, The Netherlands, Proceedings, Volume II, page. 413
- [3] J.G.L. Hendriks; M.G.M. Vrieling: Reducing ammonia emission from pig houses by adding or producing organic acids in pig manure. Ammonia and odour emissions from animal production facilities, 1997 Vinkeloord, The Netherlands, Proceedings, Volume II, page. 493
- [4] B.Nicks; A. Désiron; B. Canart: Deep litter materials and the ammonia emissions in fattening pig houses. Ammonia and odour emissions from animal production facilities, 1997 Vinkeloord, The Netherlands, Proceedings, Volume I, page. 335
- [5] P. Pedersen: Reduction of gaseous emissions from pig houses by adding sulphuric acid to the slurry. International symposium on Gaseous and odour emission from animal production facilities, 2003 Horsens, Denmark, Proceedings p. 257
- [6] D.D. Schulte: Critical parameters for emission. Ammonia and odour emissions from animal production facilities, 1997 Vinkeloord, The Netherlands, Proceedings, Volume I, page. 23
- [7] A.G. Williams; E. Nigro: Covering slurry stores and effects on emissions of ammonia and methane. Ammonia and odour emissions from animal production facilities, 1997 Vinkeloord, The Netherlands, Proceedings, Volume II, page. 421

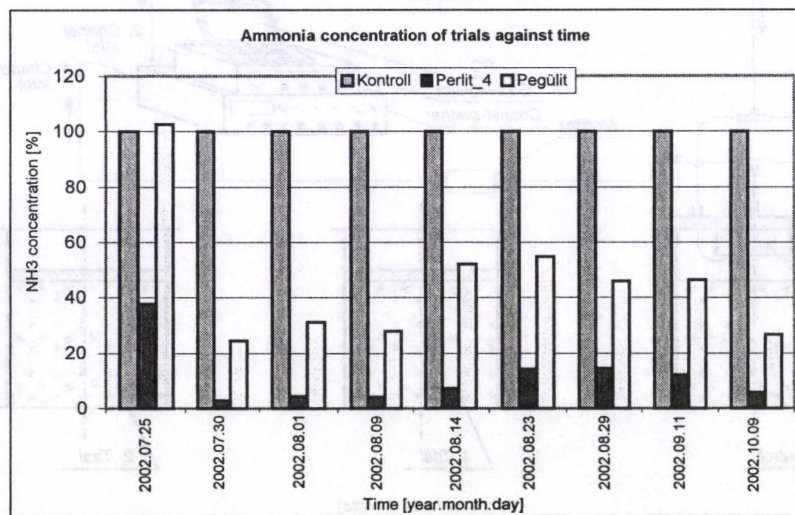

Figure 2 Diagram of NH₃ concentration against time

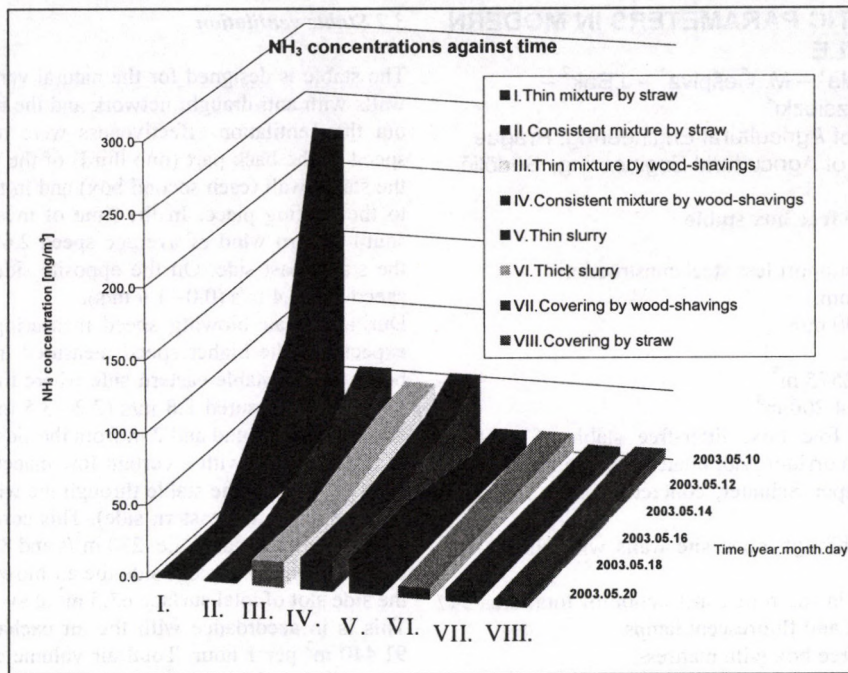

Figure 3 Diagram of NH₃ concentration against time

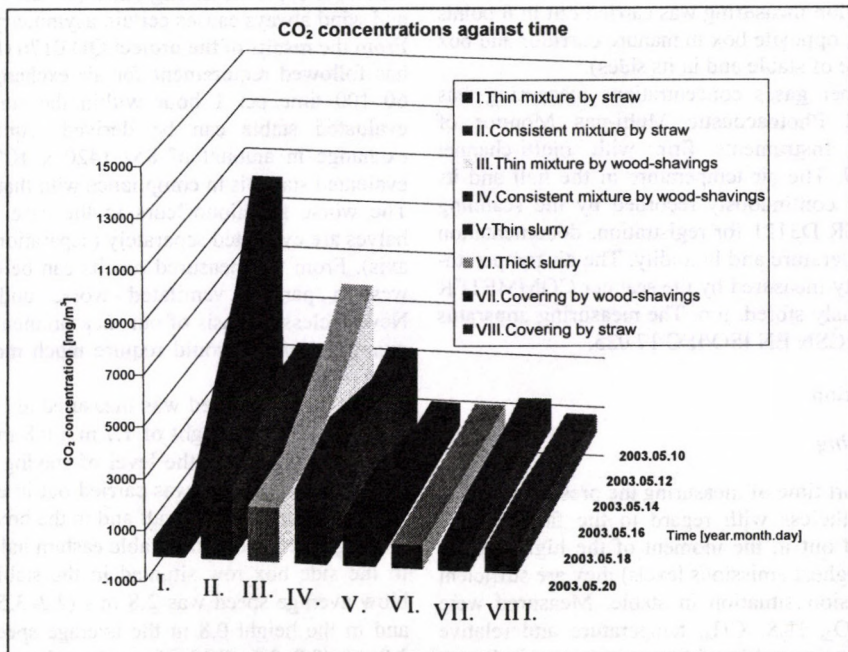

Figure 4 Diagram of CO₂ concentration against time

SUMMER CLIMATIC PARAMETERS IN MODERN FREE BOX STABLE

J. Vegrícht¹ – P. Hutla¹ – M. Češpiva¹ – J. Bak² –
L. Fenyvesi² – I. Pazsiczkí²

¹Research Institute of Agricultural Engineering, Prague

²Hungarian Institute of Agricultural Engineering, Gödöllő

1. Introduction of the free box stable

Construction system: support less steel construction

Stable width: 31 400 mm.

Roof ridge height: 9250 mm.

Eaves height: 2730 mm.

Ground plan surface: 2575 m²

Stable inner volume: 14 200 m³

Housing technology: free box, litter-free stable, 6 rows of boxes, central feeding corridor with bilateral feeding place.

Manure removal: scraper Schauer, concrete storage reservoirs Wolf for slurry.

Ventilation: natural, through open site walls with sliding nets and roof ridge slot.

Lighting: light panels in the roof construction of total area 347 m², side walls with net and fluorescent lamps.

Box bed: raised litter free box with mattress.

2. Material and method

The emissions orientation measuring was carried out in 6 points in the stable (side box, opposite box in manure corridor and box in feeding site in centre of stable and in its sides).

For ammonia and other gases concentrations measuring was utilized device 1312 Photoacoustic Multi-gas Monitor of INNOVA Air Tech Instruments firm with multi-channel sampling system 1309. The air temperature in the hall and its relative humidity was continuously recorded by the scanning apparatus COMMETER D3121 for registration, documentation and evaluation of temperature and humidity. The air temperature and relative humidity measured by the scanner COMMETER D3121 were continuously stored, too. The measuring apparatus meets requirements of ČSN EN ISO/IEC 17 025.

3. Results and discussion

3.1 Emissions measuring

With respect to the short time of measuring the presented results are orientation, nevertheless with regard to the fact that the measuring was carried out in the moment of the highest daily temperature (i.e. the highest emissions levels) they are sufficient to inform about emission situation in stable. Measured were emissions of NH₃, CO₂, H₂S, CH₄, temperature and relative humidity. The temperature and humidity measuring results are presented in graph of the Fig. 1.

The most important are NH₃ concentrations. There is not in the Czech Republic determined by law the highest ammonia concentration for dairy cows breeding. Müller (2001) presents normal ammonia concentration in outdoor atmosphere about 0.6 mg/m³ in the Hygienic directives, (66/1990) the highest average ammonia concentration in the working atmosphere is given in amount of 40 mg/m³ and the limit value is 80 mg/m³. Oldenburg (1989) states the maximum permitted ammonia concentration in working sites and quotes. Mothes (1973) who recommends in animal breeding maximum ammonia concentration is amount of 25 mg/m³.

We have measured in the investigated stable the ammonia concentration in amount of 0,5-1,0 mg/m³, occasionally 1.8–2.8 mg/m³ (Fig. 2.).

This ammonia concentration is too low and is close to the outdoor air value. Similarly low concentrations were measured also for other gases (Fig. 3-5.).

3.2 Stable ventilation

The stable is designed for the natural ventilation using the side walls with anti-draught network and the roof ridge slot. To find out the ventilation effectiveness were measured the air flow speed in the back part (one third) of the boxes row adjacent to the stable wall (each second box) and in the boxes row adjacent to the feeding place. In the time of measuring has blown the south eastern wind of average speed 2.6 m/s (1.6–4.1 m/s) on the stable east side. On the opposite side the air flow average speed was 0.4 m/s (0.0–1.9 m/s).

During the air blowing speed measuring in stable were – as expected – the higher speed measured in the marginal row of boxes on the stable eastern side where the average air blowing speed was measured 2.8 m/s (2.2–3.5 m/s) in height of 1.7 m above stable ground and 2 m from the side network.

We can assume with a certain low inaccuracy that the outdoor air is blowing to the stable through the whole profile of the side slot (82 m² on the eastern side). This corresponds with total air exchange in the stable, i.e. 230 m³/s and 828 000 m³ per 1 hour. Similarly on the western side the air blows to the stable through the side slot of total surface 63.5 m² at average speed of 0.4 m/s. This is in accordance with the air exchange of 25.4 m³/s and 91,440 m³ per 1 hour. Total air volume exchange found-out in the stable was 91,940 m³/hour.

From the values can be derived that the ventilation regularity in the stable depends, among others, on the wind blowing direction and wind always causes certain asymmetry of stable ventilation. From the results of the project QD 0176 (Doležal et al.) solution has followed requirement for air exchange insurance in stable 60–100 time per 1 hour within the summer period. For the evaluated stable can be derived requirement for total air exchange in amount of 852-1420 × 10³ m³ per 1 hour. The evaluated stable is in compliance with that requirement.

The worse situation occurs in the case when the stable both halves are evaluated separately (separation in stable longitudinal axis). From the measured results can be derived that the stable western part is ventilated worse under given conditions. Nevertheless on basis of our measurements this ratio can not be quantified and it would require much more detailed and long-term measuring.

The air blowing speed was measured also in the stable in some different point in height of 1.7 m a 0.8 m above stable ground, i.e. approximately in the level of staying and laying dairy cow head. This measuring was carried out in each second box in the side row of the eastern wall and in the boxes row adjacent to the feeding place also in the stable eastern half.

In the side box row situated in the stable eastern side the air blow average speed was 2.8 m/s (2.2–3.5 m/s) in height 1.7 m and in the height 0.8 m the average speed of air blowing was 1.8 m/s (0.9–2.6 m/s) in the same points.

In the boxes central row adjacent to the feeding place the air blowing speed in height 1.7 m was similarly 0.6 m/s (0.0–3.5 m/s) and in the height 0.8 m was 0.3 m/s (0.0–1.4 m/s).

Average temperature in the stable was 26 °C and relative humidity 47 % (see graph in Fig. 1.).

The above mentioned values were measured at quite normal stable operations when during the measuring all the stable doors were open. A lot of people think that better ventilation effect is achieved by opening as large as possible surface of the peripheral walls. Nevertheless the fact is that the open door eliminates considerably the chimney effect of the natural ventilation system and thus the door must be closed. Unfortunately due to the time shortage the ventilation effectiveness has not been verified at the closed door. It may be a summed that the air blowing speed would be then more regular and the average speed higher than was measured.

All the measuring was carried out together the colleagues from the Research Institute of Agricultural Engineering in Gödöllő

(Hungary) and in Prague (Bohemia) The colleagues also took part in the acquired results evaluation from point of view of criteria used in both county. The Hungarian colleagues opinion is that the evaluated stable is open insufficiently (in Hungary is required the stable air blowing speed approximately equal as the outdoor speed) and they recommend to extend the side holes surface by magnification of the side slot by about 200 mm. This requirement can be easy fulfilled similarly like the door closing what is presupposition for stable effective cross ventilation in the system of natural air exchange.

The total stable microclimate can be evaluated as very favourable (in the restaurant where we had a lunch nobody recognised that we are coming from the stable).

It is also confirmed by the dairy cow behaviour which have shown the signs of good welfare. The dairy cows have unambiguously preferred the side boxes rows, where the air blowing is most intensive.

3.3 Total heat production in the cow barn

Cows as all farm animals are homeothermal and must keep their body temperature reasonably constant. The cows dissipate heat, partly as a result of maintaining essential functions (Φ_m maintenance) and partly due to their productivity. Under thermoneutral conditions (20°C) the total heat dissipation from an cow, Φ_{tot} , mainly depends on:

- Body mass
- Production and activity level (milk, foetuses)
- Proportion between lean and fat tissue gains
- Energy concentration in the feed

Equations for total heat production, Φ_{tot}

The equations for total heat production rate under thermoneutrality, Φ_{tot} presented below are based on CIGR

(1984), CIGR (1992), Swedish Standard (1992), CIGR Handbook.

• Total heat production at 20°C, in the barn:

$$\Phi_{tot\ 20} = [5,6 m^{0,75} + 22 Y_1 + 1,6 \times 10^{-5} p^3] n \text{ [W]} \quad (1)$$

$\Phi_{bot\ 20}$ = total heat dissipation in cow barn, [W]

m = average body mass of cows [kg]; (650)

Y_1 = average milk production (kg/day); (18 kg/day)

p = average number of days of pregnancy; (135 days)

n = number of cows being in the barn; (300 cows)

$$\Phi_{tot\ 20} = [5,6 \times 600^{0,75} + 22 \times 18 + 1,6 \times 10^{-5} 135] n \times 300 = 335100 \text{ w} = 335.1 \text{ kW}$$

• Total heat production at 25oC

Total heat production per hpu (at cows)

$$\Phi_{tot\ 25} = 1000 + 4 \times (20-t) = 1000 + 4 \times (20-25) = 998 \text{ (W)}$$

hpu = heat producing unit (1000 w of total hat at 20°C)

Total heat production at 25oC, in the barn

$$\Phi_{tot\ 25\ barn} = 335.1 \text{ (kW)} \cdot 0.998 = 334.4 \text{ kW}$$

References

- [1] Ashrae Handbook, Standard. (2001 a) American Society of Heating, Refrigerating, and Air-conditioning Engineers: Atlanta, GA, USA.
- [2] Ashrae Handbook, Fundamentals. (2001 b) American Society of Heating, Refrigerating, and Air-conditioning Engineers: Atlanta, GA, USA.
- [3] Pedersen, S., (1994) Behaviour of Dairy cows Recorded by Activity Monitoring System. Third International Dairy Housing Conference, 2-5 February, Florida, ASAE Publication 12-94: 410-414.
- [4] Pedersen – Sällvik (2002) Climatization of Animal Houses, Heat and moisture production at animal and house levels (CIGR Eur.Ag.Eng.)

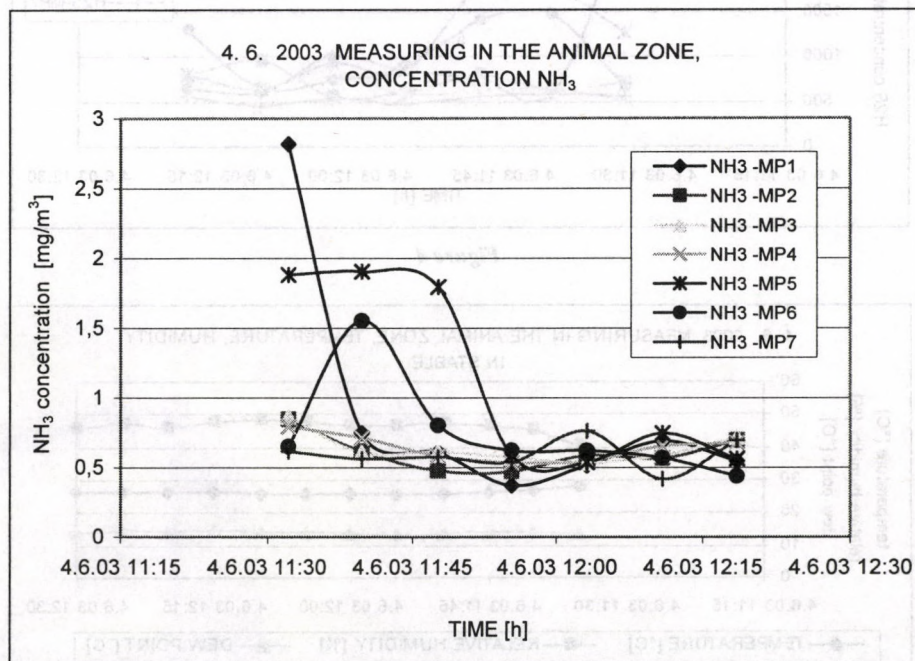

Figure 1

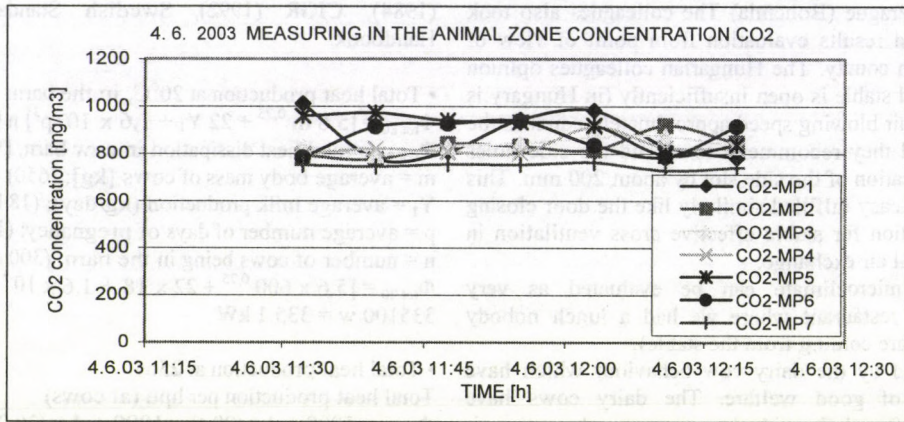

Figure 2

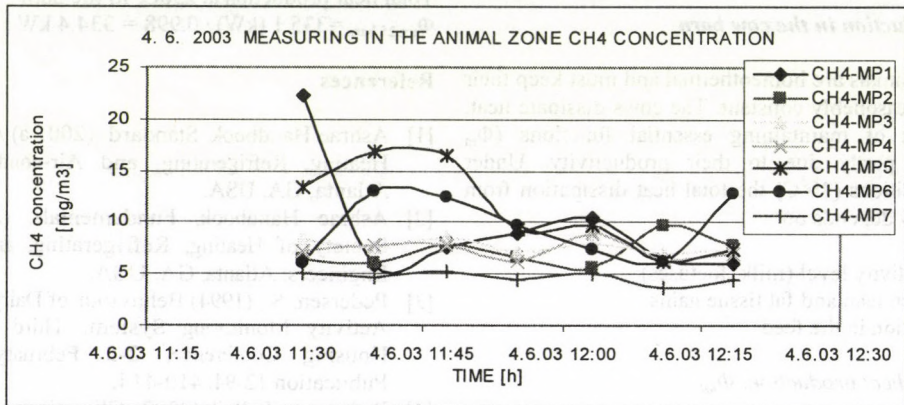

Figure 3

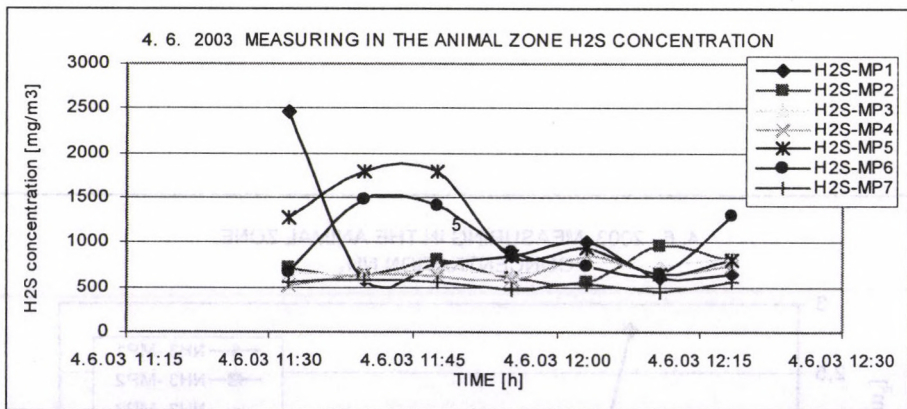

Figure 4

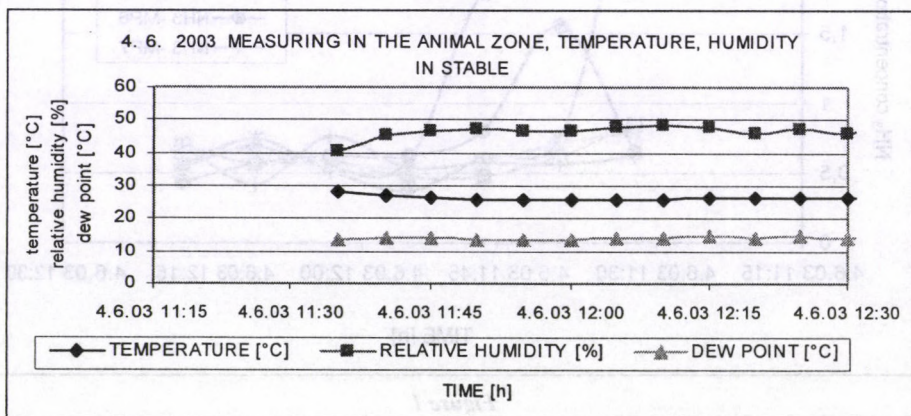

Figure 5

NEW RESULTS IN THE FIELD OF RADIO-FREQUENCY IDENTIFICATION

L. Tóth – L. Fogarasi – N. Schrempf
Szent István University, Gödöllő

Radio-frequency (RF) identifiers

The so-called radio-frequency transmitters create such an electromagnetic field at the place of the identification that induces a voltage in the activating coil of the coil (receiver) being enough to actuate it. This unit sends back a signal series of modulated frequency or amplitude toward the receiving (relay) antenna of the recognizing logic unit that can make possible to identify the signals exactly. The identifying principle and the build-up of the radio-frequency identifiers illustrated, in Figure 1.

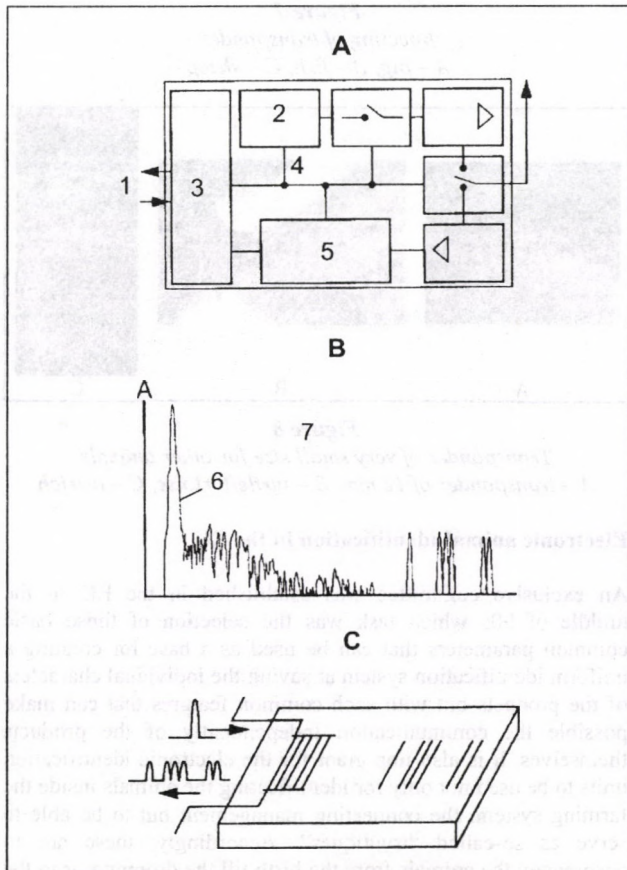

Figure 1

Opto-electronic design basing on the principle of wave-reflection from surface

A- transceiver (transmitter-receiver; reader); B - transmission;
C - identifier, e.g. crotalia with bar code

1 - computer joint, 2 - receiver, 3 - processor, 4 - scheduler,
5 - decoder, 6 - question signal, 7 - signal structure,
(Source: Reindl and Mágóri, 1966)

In the practice, both the passive transponder (resting on an external electric power-resources) and the active one (using the energy of any energy-accumulator, e.g. dry battery of lithium) have been current. In the wider range, the passive transponders are manufactured because these constructions can be miniaturized and their efficient range relatively long. Today on the dairy farms, the transponders affixed to neck straps (collars) may be accounted conventional.

At calves and pigs, the constructions of smaller size mounted in the earcrotalias can be applied well. In many points of view, the injected designs (Figure 2) are advantageous that are mini-

aturized and, after the improvement, they integrated the electronics of transponder and condensed it in an only chip. These transmitter consist of only four constructional units already.

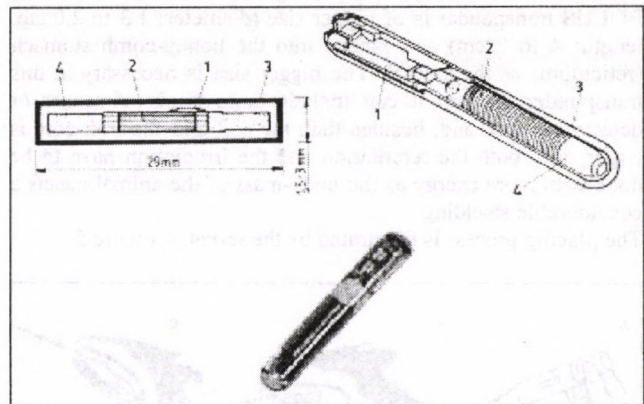

Figure 2

Design of transponders being capable for injection (125 kHz)
1 - electronics integrated in chip, 2 - coil, 3 - iron core,
4 - glass or plastic case

As the result of the manifold improvements, the energy requirement of the information transfer (emission and receiving) was decreased and the receiving distance - increased. But, a the same time, the data-transfer speed was increased considerably as well from 8 or 10 kHz to the value between 5 and 10 GHz.

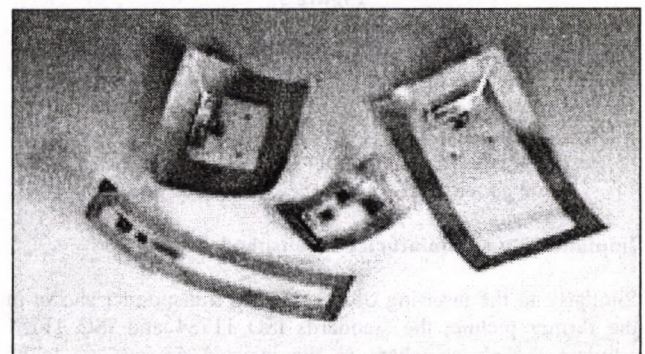

Figure 3

Design of the high-frequency foil-transponder (500 MHz)

Energy filed of 915 MHz
Transmitter
Transponder
Receiver
Response of 915 MHz + 10 kHz
Response-code
Time-signal of 10 kHz
Frequency modulator

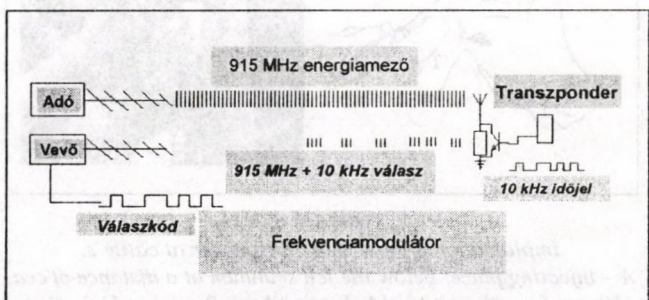

Figure 4

Communication system of a high-frequency transponder

BOLUS transponder

The so-called BOLUS transponder is counted especial in comparison with the transponder mounted on the neck of the animal and the one that can be injected under the skin. The BOLUS transponder is of bigger size (diameter: 1.3 to 2.0 cm, length: 4 to 7 cm) and placed into the honey-comb stomach (reticulum) of the animal. The bigger size is necessary at this transponder because it can include more kinds of sensor or detector as well and, besides that, the coil and the iron core is larger, too, both the reradiation and the irradiation have to be done with more energy as the body-mass of the animal means a considerable shielding.

The placing process is illustrated by the series of Figure 5.

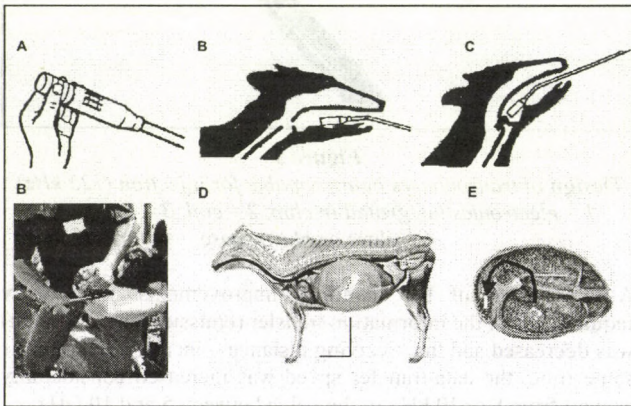

Figure 5

Having the BOLUS transponder swallowed

A – prepare the introducer unit, put the BOLUS transponder into the holder head of the instrument, B – push the introducer downward as far as the pharynx of the animal, C – then, after the deglutition function, draw out slowly the already empty introducer, now the transponder is in the food-pipe and it will be gotten from here to the stomach (D and E)

Implantation of miniaturized transponder

Similarly to the inserting of the BOLUS transponder shown in the former picture, the standards ISO 11784 and ISO 11785 regulate the places where to the injected devices are to be implanted in the animals. (Figure 6, 7 and 8).

The most experiments were carried out in the cattle farming during which it was established finally that, taking also the farm management into consideration, the most advantageous solution is if the transponder will be injected in the ear of an animal the places according to the following figures.

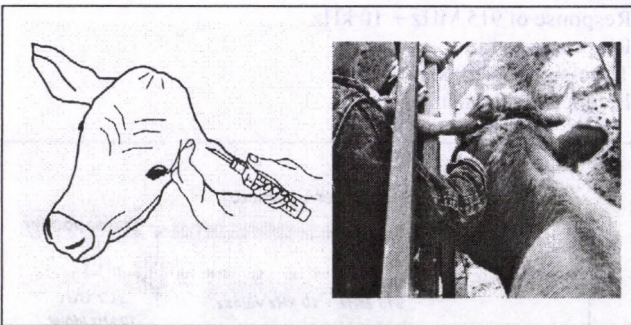

Figure 6

Implantation of injection transponder at cattle's.

A – injecting place: below the felt scutulum at a distance of cca. 10 mm from the external helix-cartilage, Process of injection: After fixing the head of the animal, without anaesthesia and spanning the ear, the injector "needle" can be introduced

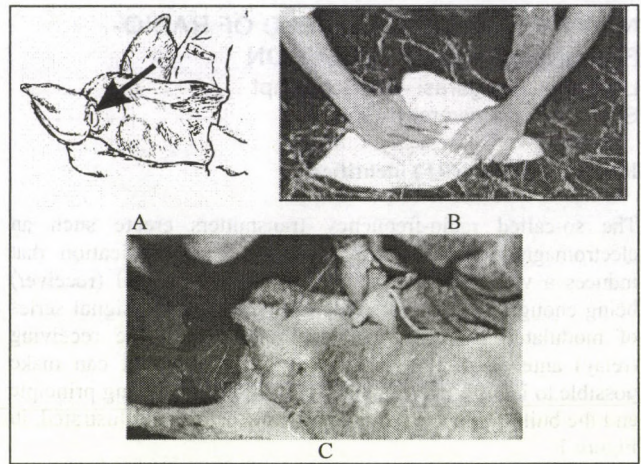

Figure 7

Injecting of transponder

A – pig, B – fish, C – sheep

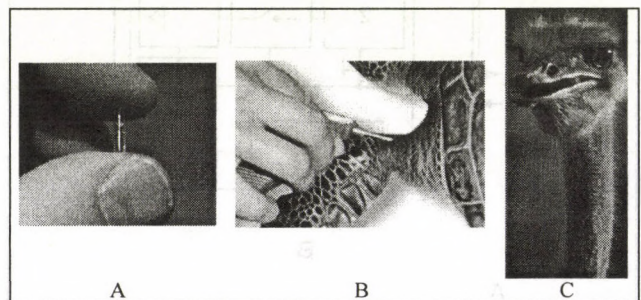

Figure 8

Transponder of very small size for other animals

A – transponder of 12 mm, B – turtle/tortoise, C – ostrich

Electronic animal-identification in the EU

An exclusive committee was established in the EU in the middle of 90s which task was the selection of those basic common parameters that can be used as a base for creating a uniform identification system at saving the individual characters of the products but with such common features that can make possible the communication independently of the products themselves. It is also important for the electronic identification units to be used not only for identifying the animals inside the farming system, the connecting management but to be able to serve as so-called "tryptiques". Accordingly, these are to accompany the animals from the birth till the dropping or to the butchery.

There has been a general direction for each animal in the European Union since 2000 that a document must be drawn up at its birth and two ear-crotalials have to be clipped on to the animal. The drawing-up of the documents like these according to the conventional process requires quite a lot of manual work. Also that is why the mechanization of the process with the help of the electronic technology has arisen. The bar-code seems to be the simplest solution and its framework is included by the standard EAN-128. Basing on these already, the different data-readouts can be mechanized as, by reading the bar-code in, the polling of the individual data is possible and, accordingly, different lists and statistics might be made. However, data in smaller number can be placed even in bar-code system as well. Accordingly the competent committee of the European Union prepared its own database encoded with suitable system of symbols. The etiquettes encoded in this way already can be used for identifying certain pieces of data without the direct access to the central database as well. Finally, its standardization is made possible through the EDI (Electronic Data Interchange) system.

The system EDI

The data flow takes place in the EDI system according to Figure 9 i.e. the breeding farms or plants of animal husbandry and the butcheries communicate with the central computer that is in direct connection with the national data bases including the ones of other countries, too.

It is disposed by the ISO standards mentioned already in particular the one of ISO 11784 contains the structure of coding while the one of ISO 11785 – the above shown technical conceptions of the transponder. For example if the identification consists of 64 bits at a device, then the first bit gives the information whether an object or an animal is identified by the code.

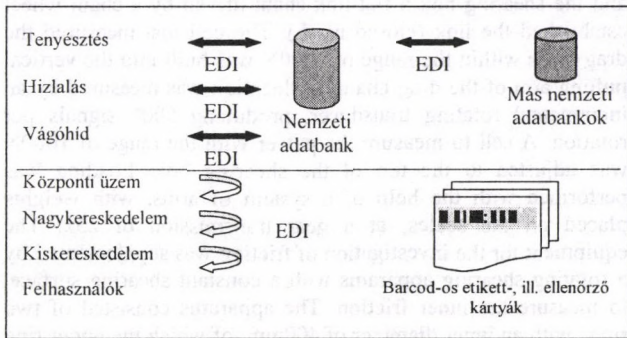

Figure 9
Data flow in the EDI system

The bits from the 2nd to the 15th making possible 16,384 combinations are reserved for the data traffic of the manufacturers.

The 16th bit gives the information practically whether a separate data bank belongs to the animal or does not.

The bits from the 17th to the 26th contain the codes of country having the possibility of 1024 combinations, according to the standard ISO 3166, from which the bits 960 to 988 are reserved for the manufacturers.

The code with the bits from the 27th to 64th serves practically the national identification system of the given country that makes possible around 274 milliard combinations for use. In this sequence, different necessary data referring to the country can be inserted for the domestic registration according to the above mentioned points of view about the birth, the species, the owner, the area of birth and the pedigree of the animal. The International Committee for Animal Registration (ICAR) completed a code list concerning the code systems of the manufacturers.

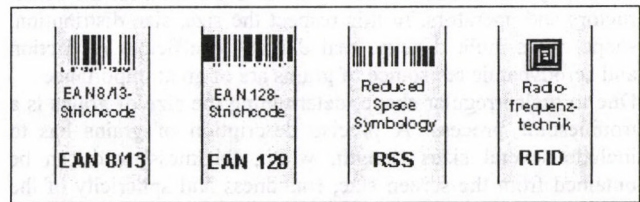

Figure 10
The systems of EAN

Results and conclusions

The main characteristics of the investigated varieties are in Table 1. The average moisture content of the samples is 7.12%.

Table 1. The main characteristics of the samples

The main characteristics	The average values
Length (mm)	2.71
Width (mm)	1.00
Thickness (mm)	0.43
Density	0.820
Moisture	0.078
Terminal velocity (m/s)	0.29
	0.01

We have chosen 150 pieces out of 160 seeds. We identified their size and size distribution.

The diameter of seeds measured on three surfaces, vertical to each other, showed an insignificant difference only, but the largest value of median value of the smallest value of the three often showed overlapping. As a result of our findings we

Materials and methods

We conducted our experiments on hemp seed investigations were performed in the research laboratory of the Department of Agricultural Engineering. The temperature of the laboratory was kept at 20 °C, relative humidity varied between 55-75%. The grain dry seed was available for determining the angle of repose and the friction coefficient which we applied in the test chamber for several months prior to the investigation. According to sampling procedure, we chose 150 seeds for determining the size, shape and weight characteristics. The moisture content of the samples of 3 x 25 g was defined at 105 °C in the course of 72 hours drying.

The angle of repose of grains was measured using a hopper box made of plexiglass 300x300mm in cross-section and 400mm in

THE PHYSICAL CHARACTERISTICS OF HEMP SEED

Z. Csizmazia, Z. – N. I. Polyák

Centre of Agricultural Sciences University of Debrecen

Introduction

Fibre reinforced polymers show excellent potentials for lightweight structures. In the paper we study natural fibre reinforced biopolymers. Hemp is one of the most important fibre plants. We also discussed the physical characteristics of hemp seed. The study and investigation of the characteristics of particles used in agriculture, mainly their physical properties have become a significant area of agricultural research. Seeds are of special importance, as they come into close contact with various machines in the course of particle moving, seeding, spreading, harvesting, cleaning, drying, processing etc. (Mohsenin, 1968, Neményi, 1985, Sitkei, 1981). The knowledge of the physical characteristics of seeds is essential for the constructors and operators. In this respect the size, size distribution, shape, mass, bulk density, real density, coefficient of friction and aerodynamic resistance of grains are of great importance.

Due to their irregular shape, determining the size of grains is a troublesome process. A precise description of grains has to include several sizes (length, width, thickness) and can be obtained from the screen size, roundness and sphericity of the grains. Among physical characteristics, frictional and aerodynamic properties are the most important for the description of seed movement.

Adjustable angled slopes, shearing boxes and various rotating disks are used to identify frictional properties. We have developed a high precision shearing box with digital force measuring cells and a distance signaller that we use for slide tests efficiently. We measured the frictional characteristics of hemp seed, on five test surfaces most commonly used in machinery, and we specified the relationship between displacement, loading and the coefficient of friction. We present the investigated surfaces in the range from the smallest force of friction to the greatest force of friction. We can conclude that the volume of the force of friction is significantly influenced by the material of the frictional surface. With the new equipment we could mathematically describe the effects of displacement and loading in the case of frictional tests (Polyák, 2001).

To identify the aerodynamic characteristics of seeds, wind tunnels and free-fall tests are used. We have developed a new elutriator for our investigation.

This study, which was supported from several tender resources (National Scientific Research Foundation, OTKA T 026482, T 037921, Higher Education Development Project, FKFP-0011/2000, National Research Development Project NKFP-4/030) describes the methods used and the devices developed to measure the angle of repose, inner friction, friction on various surfaces and aerodynamic properties.

Materials and methods

We undertook our experiments on hemp seed. Investigations were performed in the analytical laboratory of the Department of Agricultural Engineering. The temperature of the laboratory was kept at 20 °C, relative humidity varied between 25-35%. 50 kg/air dry seed was available (for determining the angle of repose and the friction properties), which we stored in the test chamber for several months prior to the investigation. According to sampling standards, we chose 150 seeds for determining the size, shape and aerodynamic qualities. The moisture content of the samples of 3 x 25 g was defined at 103±1 °C in the course of 72 hours' drying.

The angle of repose of grains was measured using a topless box made of plywood, 300x300mm in cross-section and 400mm in

height, where the front panel, (with the exception of a height of 100mm) was removable. The box was filled with grain, and then the front section was removed quickly but smoothly. By the aid of the grain level measurable above the outlet (*a*) and box size vertical to the outlet (*b*) the angle of repose was calculated on the principle of $\tan \alpha = a/b$. A friction-measuring device was developed (Csizmazia et al, 2001) for measuring the inner friction of grains and the degree of slide on different surfaces. The device contains a shearing box of two pieces with a cross-section of 200x200mm and with an inner height of 60mm. In the course of measuring, the lower frame of slight resistance was moved whilst passing over a row of ball bearings. An electric motor moved the drag frame with the help of diverting switches, back and forth. Between the drag frame and the shearing box a flat-link chain driven by a chain wheel established the link (closed mesh). The cell that measured the drag force within the range of 1000N was built into the vertical pulling arm of the drag chain. Dislocation was measured by an incremental rotating transducer, producing 5000 signals per rotation. A cell to measure the power with the range of 1000N was adjusted to the top of the shearing box. Loading was performed with the help of a system of arms, with weights placed on the scales, at a gear transmission of 25x. The equipment for the investigation of friction was supplemented by a rotating shearing apparatus with a constant shearing surface, to measure the inner friction. The apparatus consisted of two rings with an inner diameter of 400mm, of which the upper ring is fixed and can be loaded; the lower ring could be rotated. The diameter of the core parts of the ring was 100mm. The planes partitioning the inner space of the rings into compartments were of 120°. In other respects, the apparatus is similar to the shearing box.

To identify the aerodynamic characteristics of seeds, wind tunnels and free-fall tests are used. An elutriator was designed and constructed (Csizmazia et al, 2000) which consists of a 865mm long Plexiglas vertical tube with a diameter of 100mm in which airflow is supplied by a centrifugal fan. The air velocity was regulated with the modification of the fan's rpm. The air flowed from the fan through a plenum chamber upward into the 400mm long test zone of the elutriator. A lot of holes were bored on the mantle of the plexiglas tube along the test zone. Theoretically specified and precisely constructed perforation decreases air velocity with 20% in the test zone, so the suspension velocity of seeds can be measured efficiently. Perforation decreases the boundary layer and allowed the formation of a relatively flat air velocity profile in the cross-section of the test zone.

Results and conclusions

The main characteristics of the investigated sample are in *Table 1*. The average moisture content of the samples is 7.42%.

Table 1 The main characteristics of the samples

The main characteristics	The average values
Length [mm]	4.231
Width [mm]	3.460
Thickness [mm]	2.843
Sphericity	0.820
Mass [g]	0.018
Terminal velocity [m/s]	6.659
c_w	0.601

We have chosen 150 pieces out of the seeds. We identified their size, and size distribution.

The diameters of seeds measured on three surfaces vertical to each other showed an insignificant difference only, (d_1 : the largest value, d_2 : medium value, d_3 the smallest value). The values often showed overlapping. As a result of our findings we

can state that the sizes of seeds show a significant variance (Figure 1). The smallest value presented the most regular distribution. We also measured the individual mass of seed with the accuracy of 0,1 mg. The individual mass of seeds varied between 0,0070 and 0,0317 g. The value of the mass of 1000 seeds used in general practice is 18,56 gr.

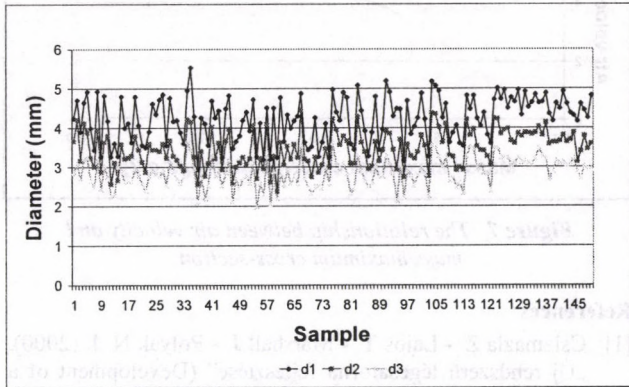

Figure 1 Diameter distribution of seeds

We investigated the coefficient of correlation between the size and the mass of seeds. We can conclude that the closest relation can be found between mass and smallest diameter. Mass, as the third degree function of the smallest size, can be identified with the accuracy of 95%, which means that despite the significant deviation of the size the seeds have regular shapes.

We defined the sphericity of seeds, which changed between 0,8-0,9. We performed statistical analyses in relation to the mass, the sphericity and the size of the seeds. The results are shown in Figure 2.

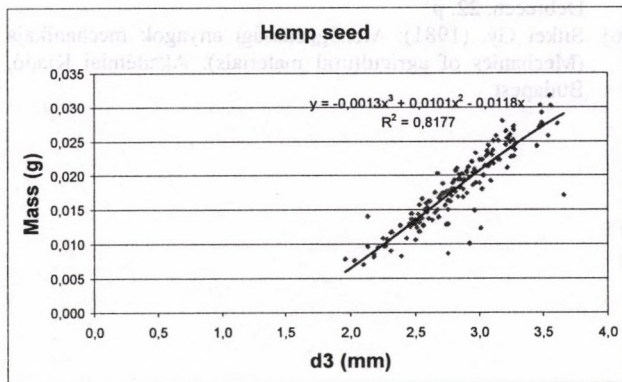

Figure 2 The relationship between the mass and the smallest diameter

For the measurements, we developed an analytical system to process the measured data, and we present the programs we developed on Excel on results from the measurement of friction. The angle of repose, the values of friction coefficient measured by slide test and the inner friction coefficient measured with rotating shearing apparatus are presented in Table 2. The values of the μ was measured in 10-40mm range.

Table 2 The main frictional characteristics of the samples

The main characteristics	The average values
Angle of repose	31° ($\mu=0.6$)
Inner frictional coefficient	0.24 - 0.37
Frictional coefficient on stainless steel	0.20 - 0.23
Frictional coefficient on black steel	0.23 - 0.30
Frictional coefficient on galvanised steel	0.24 - 0.27
Frictional coefficient on aluminium	0.25 - 0.29
Frictional coefficient on teflon	0.15 - 0.19

We examined the variations of the drag force (frictional force) related to displacement. We can claim, that the frictional force increased significantly at the beginning of the distance and reached the maximum values at the displacement of 20-30 mm, then remained unchanged (Figure 3).

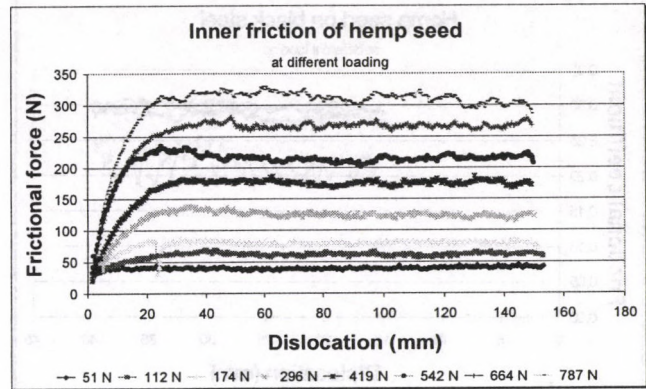

Figure 3 The relationship between frictional force and displacement

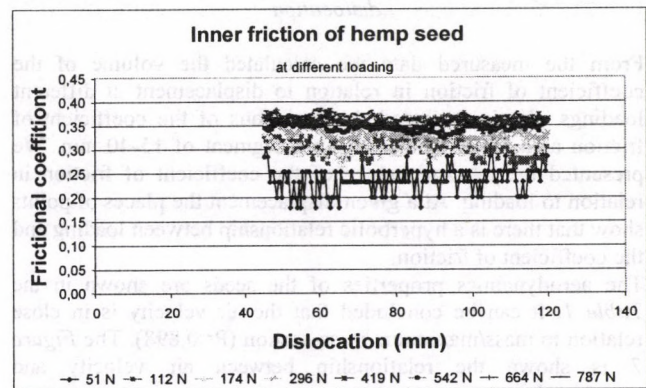

Figure 4 The relationship between frictional coefficient and displacement

We investigated the variations of the coefficient of inner friction related to displacement at different loadings in a segment of 45-120 mm. The inner friction coefficient did not change by different displacement. But at a given displacement the places of points show that there is a hyperbolic relationship between loading and the coefficient of friction (Figure 4).

We examined the variations of the drag force (frictional force) on 5 surfaces with the application of 7 loading, related to displacement. On Figure 5 the relationship between pulling force and displacement is shown, on Figure 6 the relationship between the coefficient of friction and displacement are presented, both on black steel and with different loads.

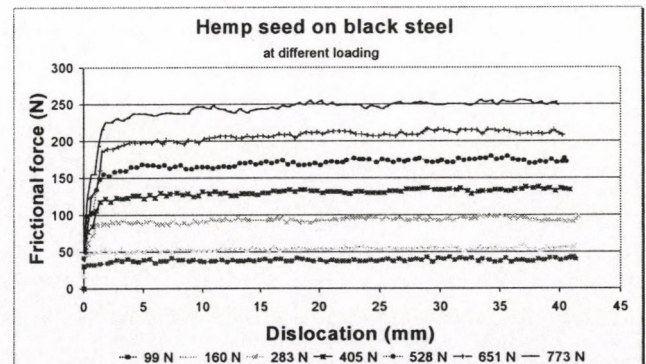

Figure 5 The relationship between frictional force and displacement

We can conclude, that the frictional force increased significantly at the beginning of the distance and reached the maximum values at the displacement of 2-5 mm, then remained unchanged.

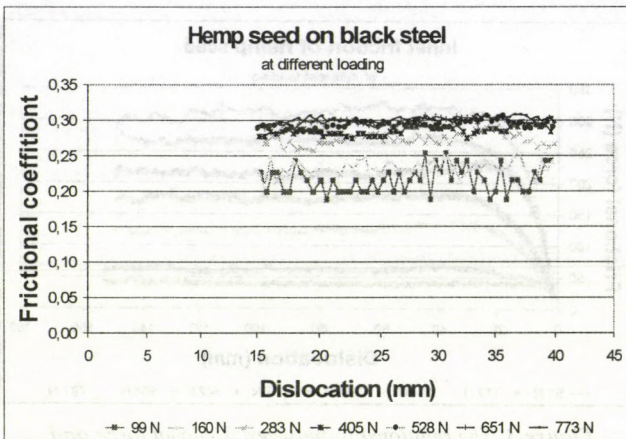

Figure 6 The relationship between frictional coefficient and dislocation

From the measured data we calculated the volume of the coefficient of friction in relation to displacement at different loadings. We investigated the variations of the coefficient of friction as a result of loading in a segment of 15-40 mm. We presented the average values of the coefficient of friction in relation to loading. At a given displacement the places of points show that there is a hyperbolic relationship between loading and the coefficient of friction.

The aerodynamics properties of the seeds are shown in the Table 1. It can be concluded that the air velocity is in close relation to mass/maximum cross-section ($R=0,898$). The Figure 7 is shown the relationship between air velocity and mass/maximum cross-section.

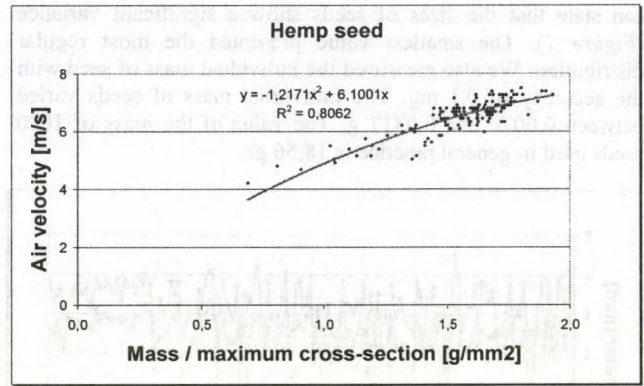

Figure 7 The relationship between air velocity and mass/maximum cross-section

References

- [1] Csizmazia Z. - Lajos T. - Marshall J. - Polyák N. J. (2000). „Új rendszerű légszatóna fejlesztése” (Development of a new elutriator), Mezőgazdasági Technika. 51. No.9. 2-5. p.
- [2] Csizmazia Z. - Ballo B. - Kasza F. - Polyák N. I. - Hagymássy Z. - Ancza E. - Gindert K. Á. (2001): Sűrűlődmérő készülék fejlesztése (Development of a shearing apparatus). Mezőgazdasági Technika. 42. évf. No 7. 4-6 p.
- [3] Mohsenin N. N. (1968). Physical properties of plant and animal materials. New York and Breach, 742.p.
- [4] Neményi M. - Szodfridt Gy. (1985): Die die Oberfläche der Körner des Hybridmais (Zea mays L.) beeinflussenden Faktoren. Z. Acker- und Pflanzenbau, 154, 217-221. p.
- [5] Polyák N. I. (2001): Búza vetőmag fizikai jellemzői (Physical characteristics of wheat seeds). Ph.D. tézis. Debrecen. 22. p.
- [6] Sitkei Gy. (1981): Mezőgazdasági anyagok mechanikája (Mechanics of agricultural materials). Akadémiai Kiadó, Budapest.

We investigated the variations of the coefficient of friction in relation to displacement in different loading in a segment of 15-40 mm. The average values of the coefficient of friction in relation to loading. At a given displacement the places of points show that there is a hyperbolic relationship between loading and the coefficient of friction. We examined the variations of the coefficient of friction in relation to loading. At a given displacement the places of points show that there is a hyperbolic relationship between loading and the coefficient of friction. We examined the variations of the coefficient of friction in relation to loading. At a given displacement the places of points show that there is a hyperbolic relationship between loading and the coefficient of friction. We examined the variations of the coefficient of friction in relation to loading. At a given displacement the places of points show that there is a hyperbolic relationship between loading and the coefficient of friction.

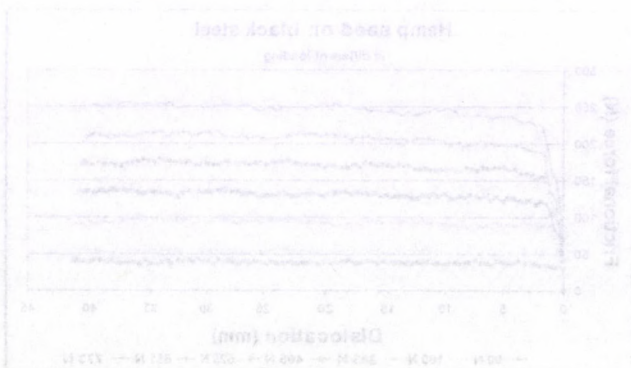

Figure 7 The relationship between frictional force and dislocation

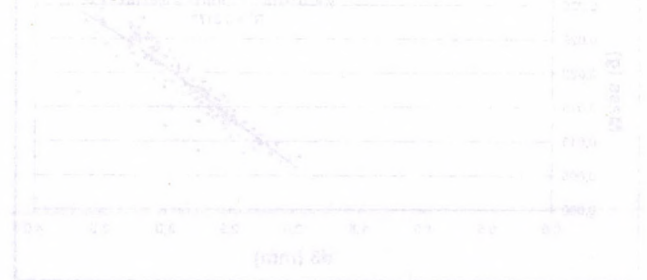

Figure 7 The relationship between air velocity and mass/maximum cross-section

For the measurement we developed an analytical system to process the measured data and we present the program developed on Excel to result from the measurement of friction. The graph of the coefficient of friction in relation to loading is shown in Figure 6. The relationship between loading and the coefficient of friction is shown in Figure 6. The relationship between loading and the coefficient of friction is shown in Figure 6. The relationship between loading and the coefficient of friction is shown in Figure 6.

Table 1. The main frictional characteristics of the samples

Sample	Frictional coefficient
Aluminum	0.12 - 0.14
Frictional coefficient on aluminum	0.25 - 0.29
Frictional coefficient on advanced steel	0.21 - 0.27
Frictional coefficient on black steel	0.23 - 0.30
Frictional coefficient on stainless steel	0.20 - 0.23
Inner frictional coefficient	0.24 - 0.27
Angle of repose	31° (40.0)

EXAMINATIONS OF FALSE HEARTWOOD FORMING IN BEECH TREE BY MEANS OF COMPUTER-TOMOGRAPH

B. Biró¹ – J. Rumpf² – G. Bajzik³ – R. Garamvölgyi³ – Zs. Petrás³

¹ Forestry and Wood Corp. of Somogy, Kaposvár

² University of West-Hungary, Forestry College, Sopron

³ Diagnostics and Onkoradiology Institute of the University of Kaposvár

1. Introduction

Color false heartwood forming is the most important structure and color anomaly of the living beech.

The presence, amount and character of the false heartwood significantly influences the value of the tree stand, so this widely examined symptom became a decisive pledge of the economical beech management by today. The ever better understanding of the appearance conditions, physiology and spreading speed of the false heartwood is very significant as to the economy.

The *value loss* resulting from the false heartwood forming – modeling the best tree stands – is 1200-4800 HUF/gross m³ (6-19 Euro) in case of medium and thick stands (counted on the basis of the total yield and counted by the 2003 February commercial prices). The *loss per hectare* in case of average age of maturity (100-110 years; $d_{1,3} = 45-50$ cm) is 1,5-1,9 million HUF (6-8 thousand Euro) (BIRÓ, 2003).

Establishment of further ecological and economical conceptions about the matter can only be made after having anti-destructive wood examination methods for the identification of false heartwood. At present it is the most challenging research area to follow the time and space development of false heartwood forming.

2. Biochemistry of false heartwood forming

In order to be able to establish research methodic for the anti-destructive detection of false heartwood forming it is essential to get to know the special tissue characteristics of the beech wood and the false heartwood in it.

The forming of the heartwood is a physiologically normal process related to the age, and the following processes take place: reduction of the moisture in the wood, thyllising of the trachea system, degeneration of nucleus and mitochondria at the parenchyma, hydrolysis of the starch and the formation of heartwood forming materials. The color of the wood is darkened by the placing in of the heartwood forming materials (MOLNÁR, 2001).

3. Requirements of the methodic

Our requirements of the method can be outlined in 5 points (SEELING ET AL., 1999):

1) It must meet the requirement of *anti-destruction*:

It is the most important requirement that during the examinations we cannot influence the expansion of false heartwood by any way.

2) The method has to map the *whole trunk slice*:

Knowing the unique shapes of the beech false heartwood (cloudy, asymmetrical shapes not following the annual rings) it is an important requirement to get results from the whole trunk segment.

3) *Sensitivity to the changes of thickness- and moisture degree*:

This requirement is a result of the differences between the tissues of the false heartwooded and the "white" wood. Our method has to be based on this difference.

4) The equipment has to be *easy to mobilize*:

The measuring instrument has to be transportable in order to be able to perform measuring in the forest resource giving place for the sampling.

5) The measuring is to be *done quickly*:

This requirement is not that significant at this stage of the research, it will be more significant when we would like to give the developed measuring instrument suitable for the practice.

4. Experiments of the near past

In the followings we would like to give a short summary of the methods and applied instruments of the various makers tested so far on living beech trunks. Quite a few of these do not meet the requirement of anti-destruction, however they are mentioned with full knowledge of the received results and in order to give a full outlining of the subject.

4.1 Instruments based on electric resistance measuring

a) TOMOPLEX (Measuring of electric resistance)

The instrument measures electric resistance. It is not destruction-free, since the measuring electrodes (24 pieces of steel claws) are to be pushed many centimeters into the trunk. The different moisture degree has effects on the specific resistance. This produces electric resistance difference that is monitored graphically by a resistance tomograph. It indicates the presence of false heartwood.

b) VITAMAT (Measuring of electric conductance)

The electrodes are pushed into the trunk step by step by the help of a crank. Each step means a resistance measuring of which the electric conductance can be calculated (reciprocal of the electric resistance) that is recorded by a calculator and is also displayed on a screen graphically. The received results can be copied to a PC and can be printed. BÜREN writes about favorable results.

4.2 Instruments based on mechanical resistance measuring

a) RESISTOGRAPH (Measures drilling resistance)

During the measuring with the Resistograph we can follow through the mechanical resistance that can be measured by the pushing of a 3 mm wide drill into the trunk. The received "resistance-segment" reflects for us the relative thickness dispersion, and the thickness differences between the annual rings. The measuring and the printing of the received curved line is done simultaneously. The received results can be copied to a PC and can be printed.

The makers testing this instrument all say that the Resistograph measurements are difficult to make and do not give certain results.

b) TEREDO (Measures drilling resistance)

Similarly to the Resistograph the Tredo Trunk Diagnostics System developed by the Technologiepark Clausthal Management GmbH is also based on the mechanical resistance measuring. REDDE (1998) performed measuring with the Tredo, however we have not found literature references about his results (IN SEELING ET AL., 1999).

4.3 Acoustic measuring instruments:

a) Acoustic microscope, process based on the measuring of vibration

According to SANDOZ and LORIN (1994) many of the measuring instruments based on the acoustic principles will have good chances in the future. The development of the instruments is under process, no literature data is available at this time (IN SEELING ET AL., 1999).

b) SYLVATEST (Measures velocity of ultrasound)

Methodic based on the measuring of the typical velocity of ultrasound in the trunk. 30 kHz medium wave is used in the equipment. The velocity of ultrasound is more or less equal in

the healthy trunk according to the known radiation and tree species. Lower velocity in the trunk refers to some kind of decomposition. BÜREN according to his conclusion does not think it is suitable for the detection of false heartwood (BÜREN, 1998).

4.4 Thermographs:

a) Thermal scanner (Process based on measuring the temperature)

NIEMZ ET AL. (1998) tested two instruments (FLIR 6200 and CLASS II THERMAL IMAGING SYSTEM) that take measurements in the infrared radiation range. During the process radiation of heat is measured on the surface of the trunks and then picture is made of it. The method is not suitable for the safe detection of false heartwood forming.

4.5 Computer-tomographs:

Computer-tomography as a possible anti-destructive picture making means of detecting false heartwood by the examination of a trunk slice was first written down by HABERMEHL and RIDDER. They were also the ones, who made the first such measurements with the help of a Caesium-spring (Cs-137). According to the conclusions of SEELING ET AL. the TREE-TOM mobile equipment used by them is suitable for taking measurements on the living tree trunk.

Mobile CT was used on a living tree by very few with very varying results for the detection of false heartwood (IN SEELING ET AL., 1999).

5. Research methodic

Computer-tomography is a segment examination method by the use of X-ray with digital-computer data processing. The essence of computer data collection necessary for the picture making is that the system of the X-ray tube giving the X-ray and the sensor located on the opposite side turns 360° around the segment of the chosen trunk, and during this process the detectors detect the X-rays of different intensity on the given segment. The segment CT picture reflects well the visible shape by giving grayness scale (Hounsfield-scale) in order to disperse absorption (SZAKÁLY, 2003).

The discs to be examined were from the Cserénfa 24/E forest subcompartment of the forest management areas of the Zselicség. The discs were cut off at the height of 1,3; 4 and 8 meters. The thickness of the discs was 30 cms their diameters were 36-58 centimeters. After taking the samples they were put in plastic foil so as to avoid the possible changes of the moisture. The examination of the sample discs was done in 12 hours.

SIEMENS SOMATOM PLUS 40 type computer tomograph was used for the examination.

6. Results

By comparing the cross-sectional CT picture with false heartwood picture on the disk we can state, that:

- the applied method detects the presence of false heartwood,
- the border of false heartwood is clear and is the same as on the real picture,
- we receive good quality information of all the surface of the tree segment,
- the presence of the false heartwood is easy to detect, no long evaluation experience is needed for the evaluation,
- it provides excellent possibility for the examination of the annual ring structure.

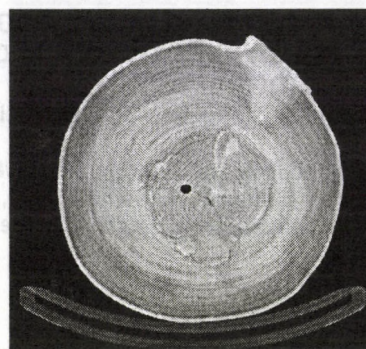

Figure 1 Cross-sectional CT-photo of false heartwooded beech-disk

7. Conclusions

The researches done so far and the expected future results – taking into consideration the technical level of our days – do not make the operational computer-tomograph examinations of even the most valuable beech forests possible at the thinnings or at preparatory cuttings.

However the explosion-like development of computer-technology and instrumentation may lead to a detector – that is so far imaginary – that is easy to take along, is fixed on a telescope stand that is attached around the tree and by slowly lifting up the telescope up to the height of 6-8 meters, it can detect the usually fusiform false heartwood with the demanded accuracy and unanimity.

It is important however to state that as long as the costs of the measuring possibilities outlined before are not reduced to the level that they not exceed the extra profit that might be realized by their use, such a mobile instrument would get a place only in the researches and not in the practice.

8. Latest results

Simultaneously with the CT examinations we made tests with core magnetic resonance. The MR picture making is based on the use of magnetic field and radio waves. Contrary to the CT that can make only axial pictures, the MR equipment can make pictures in any levels. The picture making based on the NMR technology is based on the qualities of the hydrogen atom that is the most frequent element of the human body.

The structure of the trunk disk is easy to identify on the MR photos, as well. The elements of the wood that have effects on its MR appearance are not yet exactly known, further examinations are needed in this regard.

References

- [1] B. BIRÓ (2003) Untersuchung der Entwertung wegen Rotkernbildung an Beispiel der Buche. Discourse. 36. Forstökonomisches Kolloquium, Sopron
- [2] VON BÜREN, S. (1998). Buchenrotkern. Erkennung, Verbreitung und wirtschaftliche Bedeutung. Schweizerische Zeitschrift für Forstwesen, P.955-970.
- [3] MOLNÁR S. (2001). The false heartwooded wood has excellent qualities! Wood industry 19.
- [4] SEELING, U., BECKER, G., SCHWARZ, C. (1999): Stand der Buchenrotkernforschung und zerstörungsfreie Erfassung des Rotkerns bei Buche (*Fagus sylvatica* L.). Interner Abschlussbericht. Institut für Forstbenutzung und Forstliche Arbeitswissenschaft, Universität Freiburg.
- [5] SZAKÁLY SZ. (2003): The possibilities of the CT and MR picture making processes in the diagnosing of some of the illnesses of the dogs. Degree work, University of Kaposvár.

ANALIZATION OF THE POSSIBILITIES OF BASIC MATERIAL SUPPLY OF WOOD-BASED POWER PLANTS WITH USING FORESTRY INFORMATICAL DATABASE

B. Marosvölgyi – L. Jung, PhD. stud. – J. Kovács
University of West-Hungary, Sopron

Introduction

In Hungary in the time of EU-connection the woodenergetics is in the state of meaningful development which is in relation to the European Union technology regulations and other international treaties.

It is explained by that the increasing of the present, low share of renewable resources (3,4%), which has to be raised 7% by 2010., 12% by 2015. For this kind of increase the european tendency is required in Hungary to reach the 3,6% the renewable resources of the hungarian eletricity supply by 2015. From the present 0,35%.

Meaningful development are essential to reach these aims.

Analyzing the possibilities of developments, it can be stated that (same as the abroad solutions) the solid biomass can have important function. Among the solid biomass the wood has determinative role. It can be explained by the good characteristics of wood as an energy carrier, besides the properties of its production, harvesting, storing and other logistics are more favourable than other lignocelluloses.

In Hungary a few years ago the wood function of electricity production was insignificant yet, though earlier in several wood-processing plants generators, which was drove by steam-engine, were worked for satisfaction of their own electricity requirements.

According to the statement of national woodenergetics researches, the wood utilization in the eletric power supply is to be reasoned. It has three main possibilities:

- Eletric power production in cogeneration in small performance micropower plants, with local heat utilization,
- Electricity production in the centre of natural or cultivated basic material establised power plants, partial or total heat utilization,
- Electricity production in such power plants, which earlier supplied by other energy carrier, based on special logistic system.

In Hungary under the influence of the characteristics of the energy sector and the aggravation of enviromental prescription several power plants were essential to change their boiler. Among these , the AES Power Plant in Kazincbarcika is connected to our present research. The earlier coal based power plants changing for wood based are going on at present.

The more important properties of the AES Power Plant in Kazincbarcika:

The numbers of the boilers which have autorization:	8 piece
The number of turbines:	3 (condensationner) + 1 (by steamservice connected)
Total performance:	
Nominal power performance:	90 MW condensationner (direkt eletricity production) + 5 MW connected eletric power production
Heat performance:	The input performance of the boilers (one by one) approximatly 90 MW, heat output 75 MW.
Eletric power output:	The condensationner turbines are one by one 30 MW.

The heat output of the changed blocks:	The heat output of the boilers 75 MW (altogether two boilers)
The eletric power output of the changed blocks:	The two boilers can drive the two turbines with medium high performance (one by one 22 MW). This means comparatively 38 MW eletric power. (The different of the two numbers is the so-called housedrive, which is equal to the driving iof the macjhines for sustainableng of the production.)
The wood requirements of the Power Plant:	In the changed boilers of the power plant the all useable wood amount (depends on the moisture content) 360.000-380.000 lutro tonns/year.
The flow of material of transporation:	Approximately 230.000 tonns firewood, chips and sawdust can be waited, and 20.000 tonns sunflower seed in 2004.
The safety reserve:	Yearly average approximately 25.000 tonns, in peak maximum 50.000 tonns.

Either part of the wood requirements of the power plant is made certain by Egererdő Joint-stock company.

In connection with the requirements of the woodmarket, several, new exercises are appeared which were not typical in the forestry in the past. One part of these exercises is economical, the other part is technological.

It is very important that the pace and the possibilities of the logging are determined by 10-year-old management plan which plans are exclusively based on ecology. Moreover , with counting of the fact that the energetical basic material utilization is in fuel values ration price category. The so-called lower economy rate and first the regeration of the damaged forest is seemed to adequate economically, thus their execution of the management plan possibilities can be realizable.

For the establish of middle-distance transportation engagement, the informatic system of the joint-stock company were used.

On the basis of the timed database it can be stated that (also regarding the accumulation) the fulfilment of the middle-distance pledge can be made certain on the wood basic material of the joint-stock company.

The new came up problems:

- The transportation is made in the whole year, and this kind of periodically made logging is not organised without intermediate storing.
- The flow of material of logging workplaces and the flow of material of transportation are meaningful different.
- The logistic consideration the either logging regions are meaningful different of each other.
- The logging techniques and the stockpiling require new solutions in the area of energywood production.
- The special transportation exercises need new technological solutions.
- The structure of the assorment can be fastly transformed.

In 2001 with the aims of the fitting of the problems, from time to time the modelling of the problems, the informatical database of the joint-stock company was started to develop. The characteristics of the system:

The field units of the EGERDŐ Joint-stock Company are connected by rented line system (Multi-LAN)

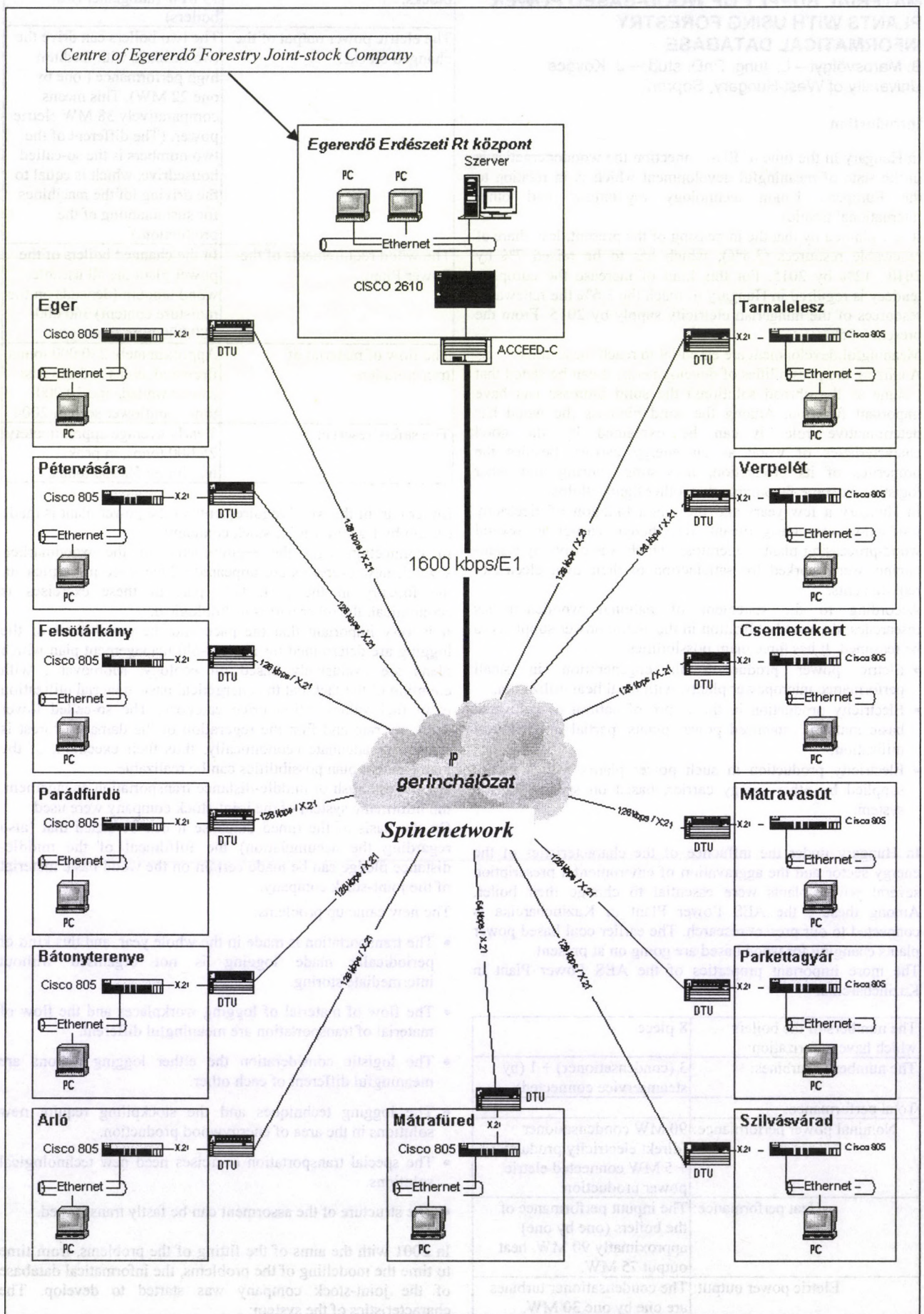

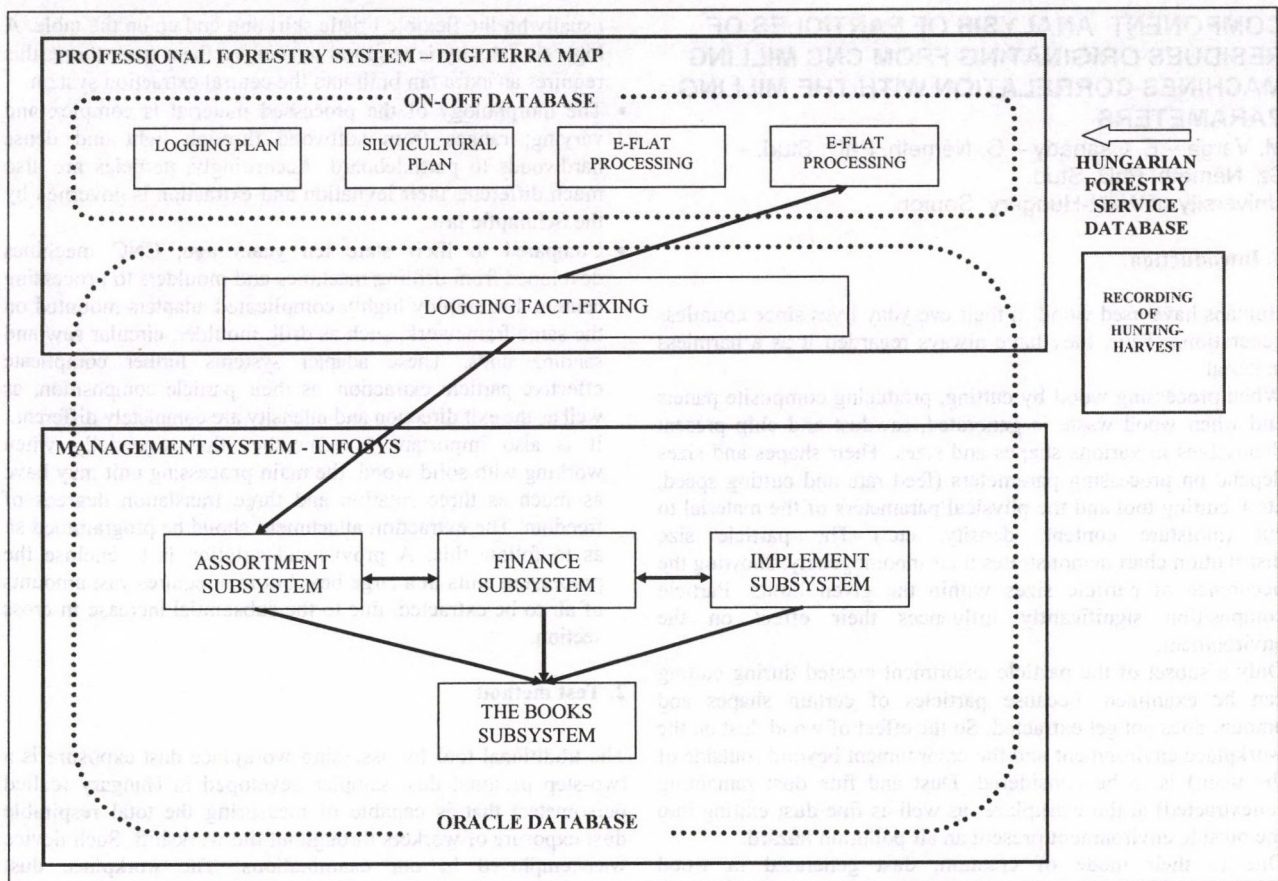

The following transportation pledge was taken by the joint-stock company with the utilization of the database:

	2000-2002. average	2003.	2004- 2012. average
Gross logging (thousand m ³)	240	266	245
Net logging (thousand m ³)	185	199	190
<i>From the logged wood volume:</i>			
Log (thousand m ³)	44	39	40
Stacked other assortment (thousand m ³)	131	153	150
Firwood (thousand m ³)	99	126	130
Energetical wood (thousand m ³)	0	40	60-100
The holding of the logging in 200-2002. because of sale problems: 60–90.			

References

- [1] MAROSVÖLGYI B. - RÉDEI K. (1996): Black locust Energy-Forest. (in: F.S.E.: BLACK LOCUST GROWING IN HUNGARY.) Bpest. 23-26. p.
- [2] MAROSVÖLGYI B. at al. (1999): Poplars as biological energy sources in Hungary. Biomass and Energy 16 (1999) 245-247 PERGAMON/USA
- [3] MAROSVÖLGYI, B (1999.): The role of agriculture in the energy generation. Small-Scale Biomass Burning. (Inco Cop. Proj.) Int. Sem. Proc. 47-53. p.
- [4] MAROSVÖLGYI, B. - Mészáros E. - Jakab E. - Várhegyi G.(2001): Thermal Behaviour of Biomass Plant Materials. Research Laboratory of Materials and Environmental Chemistry, Chemical Research Centre, Hungarian Academy of Sciences, Institute of Energetics, University of West Hungary
- [5] MAROSVÖLGYI, B et al.: A biomassa felhasználása. MgK. Budapest 2002
- [6] MAROSVÖLGYI, B - Kovács J - T. Lukac (2003): Az energetikai Fanyersanyag-bázis bővítésének műszaki fejlesztése. MTA-AMB Konf. Proc. 2003
- [7] MAROSVÖLGYI, B. - Vityi A. - Ivelics R.(2003): Experiments on briquetting and firing energy plants. Consultation theme. In: 4th International Symposium „Materials from Renewable Resources”, Erfurt, Germany.
- [8] MAROSVÖLGYI, B.-Vityi, A.(2003): Energieproduktion aus Biomasse in Ungarn. Int. Konf. Leipzig.
- [9] MAROSVÖLGYI, B. - Vityi A. - Ivelics R. - Szűcs Szabó L. (2003): Increasing the raw material basis of Bio-briquette production by using new materials. Int. Konf. Basel.
- [10] MAROSVÖLGYI, B.(2003): Fafeldolgozási melléktermékek és hulladékok brikettálása. Faipar 2003/03
- [11] MAROSVÖLGYI, B, E. Mészáros, G. Várhegyi, E. Jakab (2004): Thermogravimetric and reaction kinetic analysis of biomass samples from an energy plantation. Energy Fuels, 18 (2004) 497-507.
- [12] MAROSVÖLGYI, B. - Ivelics R. - Püske J (2004): New results of utilization and mechanization of harvesting of short rotation coppice. Presentation. In: 26th International Conference of CIGR Technical Section IV „Electricity and Energy in Agriculture”, Budapest, Hungary.
- [13] MAROSVÖLGYI, B. - Ivelics R.(2004): Research Report on wood-chips and energy wood production experiments. In: Energy Forest Project, Hungarian Experiments, Budapest. In:www.energyforest.com/szovegek/tat_exp.pdf
- [14] MAROSVÖLGYI, B. - Vityi A. - Ivelics R. - Püske J. (2004): Experiments on the mechanization of harvesting of short rotation coppice in Hungary. 2nd World Conference and Technology Exhibition on Biomass for Energy, Industry, and Climate Protection. Palazzo dei Congressi Rome, Italy.

COMPONENT ANALYSIS OF PARTICLES OF RESIDUES ORIGINATING FROM CNC MILLING MACHINES CORRELATION WITH THE MILLING PARAMETERS

M. Varga – E. Csanády – G. Németh, PhD. Stud. – Sz. Németh, PhD. Stud.
University of West-Hungary, Sopron

1. Introduction

Humans have used wood in their everyday lives since countless generations. Thus, they have always regarded it as a harmless material.

When processing wood by cutting, producing composite panels and when wood waste is generated, sawdust and chip present themselves in various shapes and sizes. Their shapes and sizes depend on processing parameters (feed rate and cutting speed, etc.), cutting tool and the physical parameters of the material to cut (moisture content, density, etc.) The particle size distribution chart demonstrates their inhomogeneity, showing the occurrence of particle sizes within the given limits. Particle composition significantly influences their effect on the environment.

Only a subset of the particle assortment created during cutting can be examined, because particles of certain shapes and amount does not get extracted. So the effect of wood dust on the workplace environment and the environment beyond (outside of the plant) is to be considered. Dust and fine dust remaining (unextracted) at the workplace, as well as fine dust exiting into the outside environment present an air pollution hazard.

Due to their mode of creation, dust generated in wood processing plants is considered as "technical dust". In terms of chemical composition, on the other hand, they are regarded as dust of organic origin.

Depending on the type of the particular woodworking plant, other chemical materials of various composition are mixed into wood dust, e.g. lacquer dust or simple dirt from the plant floor. These materials represent a health hazard when inhaled into the respiratory system, and cause various respiratory diseases. Most of these ailments produce apparent symptoms after a longer time period only. By then, irreversible changes are caused to the human organism. Most dangerous are particles between 0.25 and 0.5 μm sizes, because they are small enough get all the way to the pulmonary vesicles upon inhaling them, but are too large to be exhaled.

Past experience shows that, in case of traditional woodworking machines an effective extraction system could be designed and implemented, although it took a long time. This provides the required low dust concentration in the environment, provided that operation instructions are complied with.

Increased productivity and flexibility needs brought about the genesis of CNC processing centers. Today these centers have ample flexibility with regards to cutting, but not in terms of dust extraction.

This is due to the following reasons:

- Wood processing centers inherited their construction entirely from the metal industry, where particle mass excluded the possibility of pneumatic extraction, and the amount of chips is smaller, too.
- Woodworking industry uses tools of various sizes and high cutting speeds. In the case of molder tools – most often used for wood – chips exit radially, a trajectory imposed by the centrifugal forces. Due to the requirement of flexibility, the presence of a tool magazine and the edge molding often needed for wood, radial (i.e. optimal) extraction attachment cannot be used. The carrier airflow is vertical, and particles are forced to make a 90° turn. The larger the chip, the more difficult this is to do, due to their momentum. These particles

usually hit the flexible bristle skirt and end up on the table. A high air velocity is required to remove them from there; this requires an extra fan built into the central extraction system.

- The morphology of the processed material is complex and varying; ranges from softwood through light and dense hardwoods to particleboard. Accordingly, particles are also much different; their levitation and extraction is governed by the Schimpfle law.
- Compared to their state ten years ago, CNC machines developed from drilling machines and moulders to processing centers that employ highly complicated adapters mounted on the same framework, such as drill, moulder, circular saw and sanding units. These adapter systems further complicate effective particle extraction, as their particle composition, as well as the exit direction and intensity are completely different. It is also important to remember that, especially when working with solid wood, the main processing unit may have as much as three rotation and three translation degrees of freedom. The extraction attachment should be programmed so as to follow this. A provisional solution is to enclose the processing units in a large box, but this requires vast amounts of air to be extracted, due to the substantial increase in cross section.

2. Test method

The traditional tool for assessing workplace dust exposure is a two-step personal dust sampler developed in Hungary (called persometer) that is capable of measuring the total respirable dust exposure of workers throughout the workshift. Such device was employed in our examinations. The workplace dust exposure tests were carried out in Hungarian woodworking plants. The plants represented a wide scale of machine types. Very modern, new and used multi-head CNC processing centers and different types of traditional basic woodworking machines, in greatly variable states of repair, were included in the assortment.

Thus, our tests involved single and multi-axis CNC processing centers with varying degrees of freedom, multi-axis cross-section moulders (covered and uncovered), combined and contact sanders, band- and edge sanders, drum sanders, log and small band saws, circular saws of various sizes, single and multi-axis planers and moulders and their combinations, frame saws, mortise drills, as well as worksites where handheld cutting and sanding machines

are employed. Plant sizes varied as well; they ranged from small businesses that utilised one or two machines up to large and modern high capacity enterprises.

In small plants, machines (usually five to ten) were typically installed in the same room, and used on an alternate basis, i.e. not throughout the shift. The type of material processed within a shift varied as well. In larger mills, machines serving different technological purposes were put in separate rooms, (i.e., cutting, sanding and hand workshops, etc.) and most machines usually worked all throughout the shift.

As a matter of course, machines in woodworking plants generate dust and chips, that must be removed for technological, safety and, last but not least, occupational health reasons. Considering the typically high cutting speeds (20-70 m/s) during wood processing, dealing with the dust and chips created is not a simple task.

Particle composition generated when cutting wood is extremely heterogeneous, ranging from a tenth of a micrometer to the mm or even cm sizes. Moreover, the type and moisture content of wood and the cutting direction, all of which influence the size and aerodynamic characteristics of the particles, are also greatly variable.

Similarly to the condition of the woodworking machine that can be very different (ranging from a hundred year old to modern),

there is more than one way to remove dust and chips. There are really three different types of solutions:

"A" – Machine can not be connected into the extraction system (no extraction attachment), or it has not been connected.

"B" – So called individual extraction and dust removal unit, used especially for small businesses.

"C" – So called central extraction system, used mainly for larger plants. One or more such device might be used.

3. Discussion of the results

Based on the measurement results, and on the measurement conditions, the factors that basically determine workplace dust exposure are, as follows:

1. The cover of the machine or other dust generation site,
2. The efficiency of the extraction system connected to the cover,
3. Removal efficiency of the extraction system.

These are the factors that have to be examined along with the dust concentration measurements, especially if the latter show unacceptable values. These are also the main areas where most problems arise that need to be solved. Complying with workplace dust concentration regulations is of course not only a technical question, but a matter of economy, too.

Accordingly, the least expansive solution to push the dust exposure values under the limit has to be found. Direct and indirect expenses (e.g. more expensive machine construction) can be classified into three main categories:

I. Building an efficient extraction attachment.

The criteria for such are:

- striving for a better tool cover and a small dust escape area,
- placing the attachment near to where dust and chip are generated,
- utilising the initial kinetic energy to assist the particle in getting into the extraction attachment,
- The right configuration of the attachment is vital in terms of workplace dust concentration.

Decreasing dust exposure by designing a good extraction attachment according to the above criteria presents a one-time expense.

II. Using the right extraction system

Any of the dust created at the work station that does not enter the system is basically lost; it stays at the worksite as a pollution agent.

The second important criterion after a good attachment is sufficient suction speed. This might not mean a great speed. This is important, because the energy needed for high-speed extraction and for adding extra air translates into increased expenses.

III. Cutting tool and parameters

These factors influence particle composition, initial speed and, through these, workplace dust concentration. The tasks ahead should be assessed in the light of the above considerations. Because of the hazard involved with wood dust, the task of the future should be to push the workplace dust concentration to the lowest possible level. The 5 mg/m^3 limit, presently in effect in Hungary, will be adjusted to the European value of 2 mg/m^3 , not to mention the 1 mg/m^3 limit in America. These values present serious challenges for both the industry and professional higher education.

4. The purpose of the investigation

In recent years, the attitude towards wood dust changed both nationally and internationally. Dust from beech, oak and other dense species are now considered carcinogenic, thus dust concentration at workplaces should get special attention. This

requires gravimetric dust measurements for different types of workers exposed to wood dust in the wood industry (both for traditional and for CNC machines) to assess health hazards.

In the case of traditional machines, the goal was to verify the relationships between the efficiency of the extraction systems attached to the machines (or otherwise), and workplace dust exposure.

In terms of CNC processing centers, the first machine to be examined was a router, in quasi industrial circumstances. In the first instance, the purpose of the measurements was to establish what dust and chip assortment is generated when cutting oak using different tools (16 mm and 60 mm diameter moulder heads), at various speeds and feed rates. The amount of respirable dust created when cutting particleboard, an awkward material in terms of both processing and extraction, using well maintained and somewhat neglected extraction attachments on a CNC router, was also assessed. These measurements constitute the first, vital stage of the research aimed at proposing solutions to improve to the efficiency of extraction.

5. Measurement circumstances

- Oak and particleboard were processed in quasi-industrial circumstances. Oak had 16-18% moisture content.
- 10 cutting cycles of different parameters (see diagrams 1 through 6) were carried out.
- Machine: a CNC processing center with "2.5 D" degrees of freedom.
- Tools: 16 mm diameter carbide tipped moulding tool with 3 spiral edges
60 mm diameter carbide tipped moulding tool with 2 straight edges
- Extraction system: individual extraction appliance; exact extraction parameters measured by a Prandtl tube.
- The amount of total and respirable dust in the air while cutting was measured using persometer instruments
- Dust and chips generated were examined in two parts. Screen analysis was used to assess the particles left on the table and removed by the extraction apparatus.

6. Conclusion

The measure results demonstrate that the distribution of the chip and dust extracted, as well as those remaining on the table, depend on the parameters below:

- chip thickness, length, volume, chip mass, chip geometry,
- the momentum of the chip,
- cutting speed,
- air velocity,
- extraction attachment construction,
- tool shape and ventilating action,
- extraction attachment sheathing,
- cutting direction (same or opposing),
- CNC processing center table construction (raster table or hollow table with rails.)

Based on the examinations, we can state that:

- increasing feed rate and cutting speed results in a larger fine dust fraction when cutting oak and particleboard,
- tool geometry influences the particle composition of chip and dust through chip geometry, when cutting oak,
- Higher ventilating action, resulting from certain tool constructions, makes extraction less effective and facilitates dust escape.

Only a few parameters were considered in the measurements so far, thus they can be considered as preliminary experiments towards the improvement of the extraction from CNC processing centers.

DETERMINATION OF THE ROLLING RADII IN THE INTERACTION OF A PNEUMATIC TYRE AND DEFORMABLE SOIL

P. Kiss

Szent István University, Gödöllő

1. Introduction

Rolling over terrain and vehicle travel are basically non-stationary (dynamic) processes. The dynamic effect is caused primarily by the unevenness of the terrain profile and the non-homogenous nature of the soil. Additional causes are, in case the vehicle exerts drawbar pull, the dynamic variations in resistance against the pulling force. Finally, slip can generate dynamic variations. Since these effects are stochastic, the vibrations caused by them are also random.

These vibrations, as well as causing energy losses, influence the interaction of the soil and the tyre (KISS 2001, 2003) [1,2]. The vibrational acceleration during rolling influences the radius. Changes in wheel load cause the radius to become a time-dependent variable. The change in wheel load influences the adhesion between the soil and the tyre and, consequently, the slip varies continually.

The radius which prevails during rolling is usually called the dynamic radius. However, the term, "dynamic radius" may be used to denote several different radii, such as the distance between the centre of the wheel and the bottom of the deformed tyre (UL'YANOV and MIKHAYLOV 1965) [4] or the radius defined by rolling with slip, also known as "slip radius" (KOMÁNDI 1998) [3]. The same expression is also encountered in tyre manufacturers' catalogues, where it means the radius of the rolling circle. There are three radii during rolling:

1. The distance between the bottom of the tyre and the centre of the wheel r_{cb} .
2. Kinematic rolling radius defined by motion (slip) r_s .
3. Kinetic rolling radius defined by forces r_k .

This paper presents a series of tests conducted to determine these three radii and analyses the factors which influence them.

2. Test equipment and procedures

Field tests were performed with a John Deere 6600 tractor and the measured values were stored on a computerised test apparatus. Data were measured at 0.01 s sampling rate. The tractor was operated in four different gears, with the tyres at five different inflation pressures. All tests were conducted in rear-wheel drive. (Table 1) Braking was provided by a John Deere Dyna-Cart dynamometer vehicle.

Table 1 List of some preset and tested parameters for each test run

Test segment no.	Tyre inflation pressure, bar	Vehicle velocity, km/h	Drawbar pull, kN	Slip, %	Gear
1.	1.4	4.38	17.3	18.4	B2
2.	1.4	3.82	19.2	35.9	C1
3.	1.4	4.39	19.3	36.2	B3
4.	1.4	4.65	18.4	40.6	C2
5.	1.0	3.94	20.3	26.3	B2
6.	0.8	4.28	20.3	19.6	B2
7.	1.4	5.63	-	2.09	B2
8.	1.2	3.65	19.4	31.2	B2
9.	0.6	4.56	20.1	14.6	B2

The terrain profile was measured at 20-cm intervals both before and after the vehicle passed over it, using a profilometer based on the principle of communicating vessels. The profiles were

measured at the same points both on the left and right sides before and after the vehicle passed over the test lane, relative to a fixed base. This permitted determination of the soil deformation, or sinkage, as well as the change in the profile. Each test was conducted on a "virgin" terrain segment. The soil was sandy loam. The average moisture content was 8 %. The field had been ploughed in autumn and had settled by the time the tests took place. Dry soil density was 2.7 g/cm³. Pore volume was 46.1 %.

The traction test data was stored via 15 computer channels. Torque and pull were measured by strain gauges, rpm by an electronic tachometer, vehicle velocity by radar, acceleration by 3D piezoelectric accelerometers and fuel consumption by a flow-volume meter.

The nine test runs yielded nine basic data matrixes. Because sampling was conducted at 0.01 s time intervals, there was a very large number of data points and, consequently, no need to fit curves to test points. The test data were used to compute the energetic performance parameters and determine the performance balance for a test run. The radii defined in this paper were determined from the dynamic test data.

3. Results

3.1. Distance between the bottom and centre of the wheel (r_{cb})

The bottom of the wheel is considered to be the instantaneous point at the wheel-soil interface directly under the centre. The distance of this point from the centre can either be measured or computed. It is a "radius-like" characteristic. It can be measured even while the tyre is rolling under varying load, although the required test method is not simple. To obtain this radius by computation one needs to know the static wheel radius, the vertical acceleration of the centre of the wheel, and the deformed soil profile under the same wheel measured synchronously. All three parameters are often measured during field tests. By integrating the acceleration function, one arrives at the time dependent displacement function:

$$\bar{r} = \int_{t_0}^t \left(\int_{t_0}^t \bar{a}(t) dt \right) \cdot dt + \bar{v}_0 (t - t_0) + \bar{r}_0 \quad (1)$$

The mathematical operation was performed by means of MATLAB Simulink using initial conditions $\bar{v}_0, \bar{r}_0 = 0$. The numerical integration employed the trapezoidal formula. The next step is to plot the profile of the wheel-rut and the synchronous displacement of the centre in the same coordinate system. Then the distance between the appropriate points of the two curves becomes the distance between the centre and the bottom of the wheel.

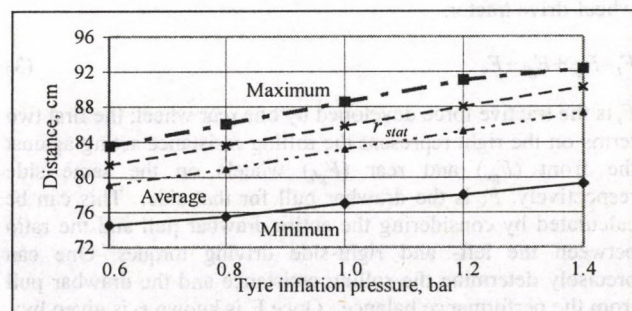

Figure 1 The distance between the bottom and the centre of the tyre (r_{cb}) as a function of inflation pressure

Figure 1 depicts r_{cb} for a Michelin 650/65R 38X M 108 tyre operating under a ~20 kN load at different inflation pressures. It can be clearly seen that the drawbar load causes a smaller

average r_{cb} for the rolling tyre than the static radius (r_{stat}) at 16.4 kN static wheel load. The diagram shows the maximum and minimum values of r_{cb} . The range within which r_{cb} varies in time can also be seen. As expected, increasing inflation pressure results in increasing r_{cb} .

3.2. The kinematic rolling radius (r_s)

This radius is derived from the kinematics of the rolling process. It is a virtual radius, and can only be computed. Its magnitude can vary between zero and infinity. When there is positive slip present (driving wheel, sometimes called driven wheel) the kinematic radius is smaller than the geometric radius and it is larger for negative slip (towed wheel). When the wheel spins in one place, r_s is zero and when it is blocked by the brake and skids, r_s is infinity. The kinematic radius, defined by slip, is given by the following formula:

$$r_s = \frac{l}{2\pi} \quad (2)$$

where l is the distance covered during one wheel revolution. Figure 2 depicts r_s and r_{cb} as a function of slip. As slip increases, r_s decreases. However, r_{cb} increases slightly with increasing slip. This is probably due to wheel vibrations caused by increasing slip. The two curves intersect at approximately zero slip. This agrees with theoretical considerations in the absence of tyre and soil deformation, since the kinematic radius at zero slip is equal to the distance between the centre of the wheel and its bottom.

3.3. The kinetic rolling radius (r_k)

The kinetic rolling radius acts in or near the interface surface of a rolling deformable tyre and a deformable soil. It is the distance between the centre of the wheel and the resultant of the elementary tractive forces acting along the ground contact surface. The magnitude of this radius determines the magnitude of the tractive force generated by the driving torque. Unlike kinematic rolling radius, its value is restricted to a narrow range.

The resultant of the elementary tractive forces does not necessarily lie on the contact surface. It may lie above it. Since the tyre is pressed deep into soft soil, the contact is a three-dimensional surface rather than a plane. The elementary tractive forces act along the entire surface. They are not distributed evenly, but proportionally to the adhesion between the tyre and the soil. As a result, the resultant tractive force acts above the bottom of the tyre.

The kinetic rolling radius is found by computation. The next formula is for the front and rear wheels on one side of a rear-wheel-drive tractor.

$$F_t = F_{ge} + F_{gh} + F_v \quad (3)$$

F_t is the tractive force developed by one rear wheel; the first two terms on the right represent the rolling resistance acting against the front (F_{ge}) and rear (F_{gh}) wheels on the same side respectively. F_v is the drawbar pull for that side. This can be calculated by considering the entire drawbar pull and the ratio between the left- and right-side driving torques. One can precisely determine the rolling resistance and the drawbar pull from the performance balance. Once F_t is known r_k is given by:

$$r_k = \frac{M_h}{F_t} \quad (4)$$

Here, M_h and F_t are the driving moment and tractive force for the same driving wheel.

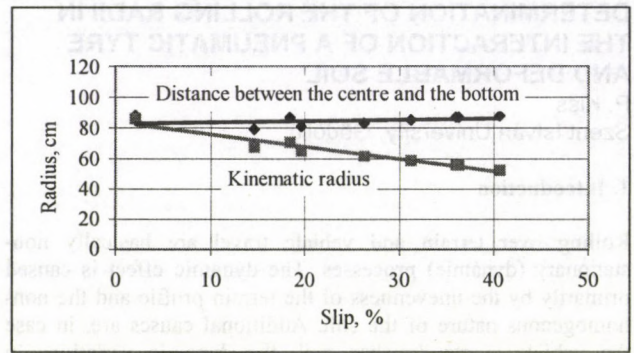

Figure 2 The kinematic radius as a function of slip. (Michelin 650/65 R 38 X M 108)

Figure 3 shows r_{cb} and r_k as a function of inflation pressure. The kinetic radius is smaller than the distance between the centre and the bottom of the tyre. This is in agreement with both theoretical considerations and practical experience.

4. Discussion

The three radii discussed in this paper have been shown to differ from each other. They are only the same in special cases. On soft, deformable soil, the centre-bottom distance is not equal to the other two radii. The physical process occurring at the tyre-soil interface is best characterised by the kinetic and kinematic radii. These two are equal only for a rigid wheel moving on a rigid surface at zero slip. (However, they may be equal for an instant as they vary due to vibrations caused by uneven soil profile.) In case of a tyre moving on soft soil there is always slip deformation and, hence, slip is always present. The two radii will thus always differ from each other. Both characterise the tyre-soil interaction; r_s characterises the interaction from the viewpoint of kinematics (slip), whereas r_k is a characteristic of the force interplay between the tyre and the soil. The difference between these two radii is best exemplified at 100 % slip, where r_s is zero, but this is when the wheel exerts the highest tractive force, and so r_k must be greater than zero.

5. Conclusions

There are three different radii for a tyre rolling on off-road terrain:

1. The distance between the centre and the bottom of the tyre, which is influenced by loading conditions and inflation pressure.
2. The kinematic rolling radius determined by slip.
3. The kinetic radius, which is the distance between the centre of the wheel, where the driving torque acts, and the tractive force generated in the tyre-soil interface.

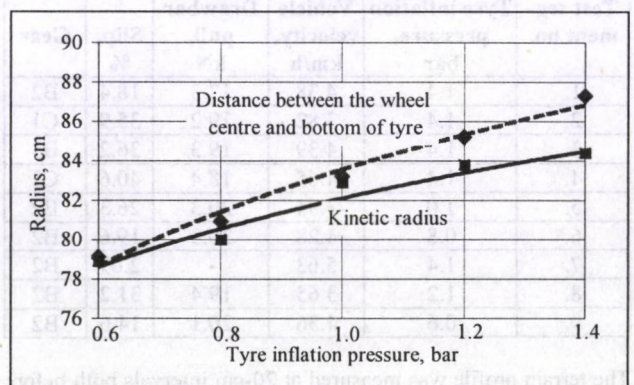

Figure 3 Comparison of the kinetic radius and the centre-bottom distance for different inflation pressures.

The kinematic rolling radius has long been derived from the distance covered in one revolution.

The kinetic rolling radius is obtained from the driving torque and the tractive force generated in the tyre-soil interface. When the tractor moves with uniform speed the angular acceleration of the driving wheel is zero. In this case, the kinetic rolling radius is defined as the distance between the centre of the wheel and the resultant of the elementary tractive forces generated in the tyre-soil interface. This can be obtained from Eqn (4).

When the wheel rpm is not constant the driving torque must be reduced by the inertia needed to accelerate the wheel.

References

[1] Kiss P. (2003). Rolling Radii of a Pneumatic Tyre on Deformable Soil In: *Biosystems Engineering* 85 (2), 153-161
 [2] Kiss P. (2001). Some aspects of the energetics of off-road vehicles. PhD Thesis Szent István University, Hungary
 [3] Komádi Gy. (1998). A kinematic model for the determination of the peripheral force. *Journal of Terramechanics* Vol. 34/4. 261-268
 [4] Ul'yanov N. A. Mikhaylov B. I. (1965). The work of the driving elastic wheel on a deforming surface. *Journal of Terramechanics* 2/2. 11-15

The author would like to thank the Hungarian Ministry of Agriculture for the financial support of this research. The author is also grateful to the anonymous referees for their valuable comments and suggestions. The author is also grateful to the anonymous referees for their valuable comments and suggestions.

The author would like to thank the Hungarian Ministry of Agriculture for the financial support of this research. The author is also grateful to the anonymous referees for their valuable comments and suggestions.

Table 1. Comparison of the number of tractors in different regions.

Region	Number of tractors	Number of tractors in 2001
Western Hungary	11187	10230
Central Hungary	1431	1377
Eastern Hungary	1431	1377
Total (2001)	13049	12984

The author would like to thank the Hungarian Ministry of Agriculture for the financial support of this research. The author is also grateful to the anonymous referees for their valuable comments and suggestions.

Table 2. Ratio of farm machinery production by region.

Region	Ratio of production
Western Hungary	0.18
Central Hungary	0.33
Eastern Hungary	0.49

The author would like to thank the Hungarian Ministry of Agriculture for the financial support of this research. The author is also grateful to the anonymous referees for their valuable comments and suggestions.

The author would like to thank the Hungarian Ministry of Agriculture for the financial support of this research. The author is also grateful to the anonymous referees for their valuable comments and suggestions.

The author would like to thank the Hungarian Ministry of Agriculture for the financial support of this research. The author is also grateful to the anonymous referees for their valuable comments and suggestions.

The author would like to thank the Hungarian Ministry of Agriculture for the financial support of this research. The author is also grateful to the anonymous referees for their valuable comments and suggestions.

The author would like to thank the Hungarian Ministry of Agriculture for the financial support of this research. The author is also grateful to the anonymous referees for their valuable comments and suggestions.

The author would like to thank the Hungarian Ministry of Agriculture for the financial support of this research. The author is also grateful to the anonymous referees for their valuable comments and suggestions.

WHY IS THE MECHANISATION OF HUNGARIAN SMALL AND MEDIUM SIZE FARMS SO DIFFICULT?

I. Husti

Szent István University, Gödöllő

1. Introduction

The current limp *competitive position* of Hungarian agriculture causes concerns for its future international competitiveness. More time will be necessary to analyse the road taken thus far. Most probably, the events of past years will serve several conclusions for the economic and agricultural history. In our present situation however, we should rather concentrate on *short-term* measures to be done to modernise and to improve competitiveness. The time available until accession is *too short* to take measures that will make marked improvements to our competitiveness in the long-term.

It is almost undisputed, that countless short and long term measures to tackle agricultural competitiveness are linked to technical capabilities and agricultural *mechanisation*. It is also accepted that within the sphere of measures required for development - taking the principle of minimum law into consideration - the tasks of mechanisation are the "spine", which best achieves the goals of development.

Therefore, in the present paper, I only look at mechanisation and primarily concentrating on the difficulties faced. I believe that it is most important to have a **correct diagnosis**, followed by a **well thought-out therapy**, whose importance is highlighted by the fact, that machinery:

- requires *significant investment*, which is relatively expensive,
- defines the prospects and limits of agricultural production for the *long-term*.

It is not a new realisation that mechanisation has an important, although not decisive, role in the *efficiency* of agricultural production. The use of machines not only replaces human and animal work, but throughout the times it has become a means of production without which large-volume agricultural production is unimaginable. In the last years, even the **economic** importance of mechanisation has become decisive: a large proportion of agricultural expenditures is associated with the use of farm-machinery.

In my earlier works I have summarised the positive and negative impacts of mechanisation and based on these, I worked out the *economic impact mechanism* of agricultural mechanisation. I proved that the realisation of the expected advantages depends on various elements, of which I consider the followings as most important:

- well-grounded reasons for deciding on machinery investment,
- the rationalism of using machinery,
- the scope and standard of customer service and
- other circumstances.

Therefore, to answer the question in the title of this paper, it is worth while flashing the disturbing impacts in the highlighted areas we are faced with "here and now".

The analysis is not complete because of the limited scope of the study.

2. Some characteristics of farm machinery

In my earlier studies - primarily based on data presented in *ÁMÖ 2000* (by HCSO-Hungarian Central Statistical Office) - I proved that the mechanisation of Hungarian agriculture lags behind its competitors' (the leading EU Member States) typical figures.

In agreement with other experts, I also think, that in the task of mechanising Hungarian agriculture, **quantitative** and **qualitative** measures need to be taken.

I see reasons in improving the *availability* of farm machinery and the *reasonable increase of the machinery density*. From the point of view of competitiveness, it is also important to replace old and worn machinery with modern technology. This is a prerequisite for compliance with the more restrictive *qualitative* requirements

According to *ÁMÖ*, the *density of tractors* in 2000 was 2.06 tractors/100 hectares that is 50-hectare agricultural land **per 1 tractor**. This figure is only one-third of the EU average and one-fifth/ one-sixth of the German and Austrian figures.

In the past two-three years, the relatively large machinery investments have improved the situation, but it is still lagging behind. The **ageing** of the tractor fleet is a serious problem. The average age in 2000 was 15.3 years. (In individual farms it was 16.1, in agricultural corporations 12.4 years. It is typical that most individual farmers can't choose but using the old machinery of the previous big cooperatives.)

Further to *enlarging* the tractor fleet, *rejuvenation* and *modernisation* ought to be also speeded up. (Almost three-quarters of the Hungarian tractor fleet is still made up of the out of date East-European models).

The situation is not much better in case of the harvester fleet, and moreover the same conclusion can be reached for **other** groups of agricultural machinery.

3. Farm-machinery investments

The farm-machinery market is supply-led. Today, somebody wanting to buy a machine can choose from 60 thousand different models. Data supporting this can be seen in **Table 1**.

Table 1 Farm-machinery market supply

Machine type	Number of types	Manu-facturers	Hungarian+Eastern +Western
Tractor	10 350	58	1+18+39
Harvester	252	10	0+3+7
Plough	1 815	61	19+11+31
Sowing machine	1 872	74	2+12+60
Sprayer	2 664	53	5+13+35
Total (2001)	55 800	1 900	

Source: Hajdú, 2003.

It is apparent that the *enlarged selection* on offer requires **expert knowledge** for the procurement decision-takers. It is not only that it is more difficult to choose from 100 models than from 10. It is also a decisive question, whether it is possible to follow the large number of different technical parameters on a daily basis. Additionally, under the competition *pressure* manufacturers *modernise* at a faster pace than before, so that they put more new models faster on the market, not taking into account whether the consumers are able to adjust - *technically and financially* - to this pace.

The data show that the supply on the Hungarian farm-machinery market has changed a lot from the usual 1/3 -1/3 - 1/3 ratio. It is now evident that *Western supply* is dominant, as shown by the figures in **Table 2**.

Table 2 Ratios of farm-machinery procurements by region

Region	Number of machines	Value of procurement
Hungarian	28,49	13,83
Eastern	4,33	16,31
Western	67,18	69,86

Source: Hajdú, 2003.

The domination of western supply alone could be welcomed, because these machines are usually of higher quality. However, it is not indifferent, what the **price** is of the higher quality. The Hungarian agricultural community is very sensitive to the cost

of development, as the 'agricultural scissors are opening permanently making critical the development of the efficiency and the rate of return and at the same time it limits the fulfilment of the classic principles of self-financing. The *small and medium-size farms* with short of capital often face with the unsolvable challenge of synchronising the force of machine procurement with their lack of capital. It is not a surprise that the most frequent motivation for their buying a farm-machine is the existence or the non-existence of **investment supports**. Except for last year, development *funding* was rather limited. The figures related to this can be seen in **Table 3**.

Table 3 Sources of farm-machinery investments in 2001

Source	Total amount (Hungarian Ft)	Ratio (%)
Own resource	37 836,8	42,28
Subsidy	24 530,7	27,41
Credit	26 713,3	29,45
Other	418,6	0,47
Total	89 499,4	100,00

Source: Hajdú, 2003.

The data clearly show that the ratio of *own risk resources* is above 70%, which again calls for the importance of a careful decision analysis before the procurement.

Knowing the previous figures it is also advisable to look at the ratio of *sectoral* procurement in Hungary in the last few years. The data related to this is shown in **Table 4**.

Table 4 Farm-machine investments per sector in 2001

Economic sector	Area of land (%)	Average area (hectares)	Investment ratio (%)
Individual farms	51,7	4,05	43,2
Economic societies	32,2	582,4	46,6
Cooperatives	15,1	1 226,9	9,5
Total	100,0	8,1	100,0

Source: Hajdú, 2003.

The table clearly show that the *individual farms* and the *cooperatives* have a lower ratio of investment per area than the *economic societies*. This fact could serve as a basis for further analyses. It seems probable, that economic societies – due to their ownership structure – still have development funds to improve their technical capability, while the individual producers and the cooperatives have already spent their reserves. This is an exciting question, as new **organisational structures** are developing nowadays, which in the next decade could be decisive for the international competitiveness of Hungarian agriculture. The development of new organisational structures is illustrated in **Table 5**.

Table 5 The organisational structure of Hungarian agriculture

Name	Forms of production			
	Number (pieces)	Ratio (%)	Number (pieces)	Ratio (%)
	1990		1998	
Enterprises with legal entity	1 990	64,0	7 703	19,7
Out of which: Economic societies	445	14,3	4 932	12,6
Cooperatives	1 362	43,8	1 715	4,4
Producers without legal entity	1 118	36,0	31 339	80,3
Out of which: Individual producers	27 832	71,3
TOTAL	3 108	100,0	39 042	100,0

Source: KSH

4. The economic problems of the use of farm-machinery

A *machinery investment decision* is a complex economic problem in itself and furthermore it influences the economic characteristics of the machine use, particularly the machine utilization and its economic effect-mechanism.

During both planning and utilising the capacities we face the problem of **efficiency**. Efficiency is a relative category; it shows the ratio of the theoretically possible and the real utilization. In case of capacity it shows in what degree we use the capacities. Efficiency has a direct effect, the better we utilise the production capacity the less machineries we need for a given production and vice versa.

After the transition in Hungary the **land structure** has changed significantly. The new conditions are unfavourable for the economic machine utilisation as the land sizes do not make the economically reasonable utilisation possible. This is the reason we have to deal with this problem further on.

5. Conclusions

- The *mechanisation indexes* of our agricultural enterprises considerably lag behind the similar indexes of EU member states. At the same time our **economic** possibilities do not permit and our **structural** characteristics do not justify a strained machinery investment. The limited financial sources ought to be spent circumspectly, and therefore deep preparations are to be done before investment decisions. The decision preparations are particularly difficult because the scope of supply has been enlarged significantly on one hand and on the other hand the professional knowledge is not always adequate.
- At judging the economic position of the sector one must consider that **self financing** is seldom possible nowadays which occasionally can cause development inability.
- The high value of most agricultural machines is a big burden not only to the *investment costs* but it influences to a great degree the *costs of utilisation* as well.
 - Under the present circumstances of the Hungarian agriculture there are more possibilities worth while to be considered for decreasing the costs of utilisation, such as:
 - Creating the conditions that a **volume** of the *tasks* should be reasonably given that makes an optimal utilisation possible. We can claim it sure enough that a farm with a couple of hectares is suitable to it only if there is a possibility to utilise the surplus capacity.
 - To work out the **amortisation policy** in order that constant costs can be divided reasonably.
 - It is practical to rethink the possibilities of utilising **used** or **amortized** machines. The obvious advantage in this case is that the large ratio of constant costs falls off. However, we must consider that the repairing costs increase and we must face if the used machines can still meet the quality requirements of the work.
- A farmer in order to get a unit of performance at the lowest possible price ought to know the level of utilisation where the specific cost the machine use is minimal. According to our trial calculations and observations we can claim that the present utilisation values are **far below** the economic expectations..

References

- [1] Hajdú J.: A hazai mezőgépi piac fejlődési alternatívái. MTA AMB XXVII. K+F Tanácskozása, Gödöllő, 2003. január 21-22.
- [2] A mezőgazdaság gép- és épületállománya. Központi Statisztikai Hivatal, Budapest, 2001.

CONTROLLING OF ENERGETIC WIND MEASUREMENT (CALIBRATION OF CUP ANEMOMETERS)

N. Schrempf – L. Tóth
Szent István University, Gödöllő

Preliminaries

One of the goals of the energetic wind measurements being carried out for several years in Dept. of Agroenergetics (Szt. István University, Hungary) was the construction of a wind tunnel that is suitable for calibrating anemometers and it is in accordance with the international standards.

Realization

The characteristic technical properties of the wind tunnel and the fan can be seen in Figure 1.

The most important constructional part of the wind tunnel is the fan type HELIOS HQ630 having impeller-blades of adjustable angle (Figure 2). During the realization the basic requirement was that the ready-made equipment should produce the wind-speed values occurring in the practice too i.e. from around 0 m/s to at least 20 m/s. This was solved with the help a frequency converter made by Procon with an infinitely variable control

range (Figure 2). The values set as an aim were managed to create only in part because the minimum value of the air velocity in the tunnel could be decreased to 4 m/s only in this way. In order to reduce the air speed further, an air-throttle plate was put in behind the fan (Figure 2) of which help even the wind velocity value approaching 0 m/s well (cca. 0.16 m/s) could be produced.

It was necessary because:

1. the earlier test results had proved that there was a significant – but, of course, not basically determining – difference in the energy content of the wind with speed starting the wind generators (2,5 m/s) and the wind with speed of 4 m/s reproduced with the help of frequency converter,
2. the test of a cup anemometer should start below the characteristic range of wind speed and end above it in order to gain the optimum information on its performance and operation in practice.

There was a further important requirements to control the dynamic loads beyond the static state.

The fan was suitable for this task as well.

Measurement

During the measurement program, anemometers type Thies were tested as:

Parameter	Measured and calculated results					
	Thies 4.3519.00.000			Thies 4.3303.22.007		
	v anemo	p	v calculated	v anemo	p	v calculated
Unit	(m/s)	(Pa)	(m/s)	(m/s)	(Pa)	(m/s)
1	1.43	1.65	1.68	1.86	1.60	1.64
2	4.07	6.64	3.34	2.91	3.20	2.32
3	5.78	19.20	5.68	3.35	4.80	2.84
4	7.87	39.60	8.16	3.92	6.44	3.29
5	9.97	64.16	10.39	4.40	9.60	4.02
6	12.15	97.36	12.80	5.13	12.80	4.64
7	13.94	128.24	14.69	6.49	22.23	6.11
8	15.83	164.32	16.63	9.64	51.20	9.27
9	-	-	-	13.03	96.13	12.70
10	-	-	-	17.42	175.88	17.18

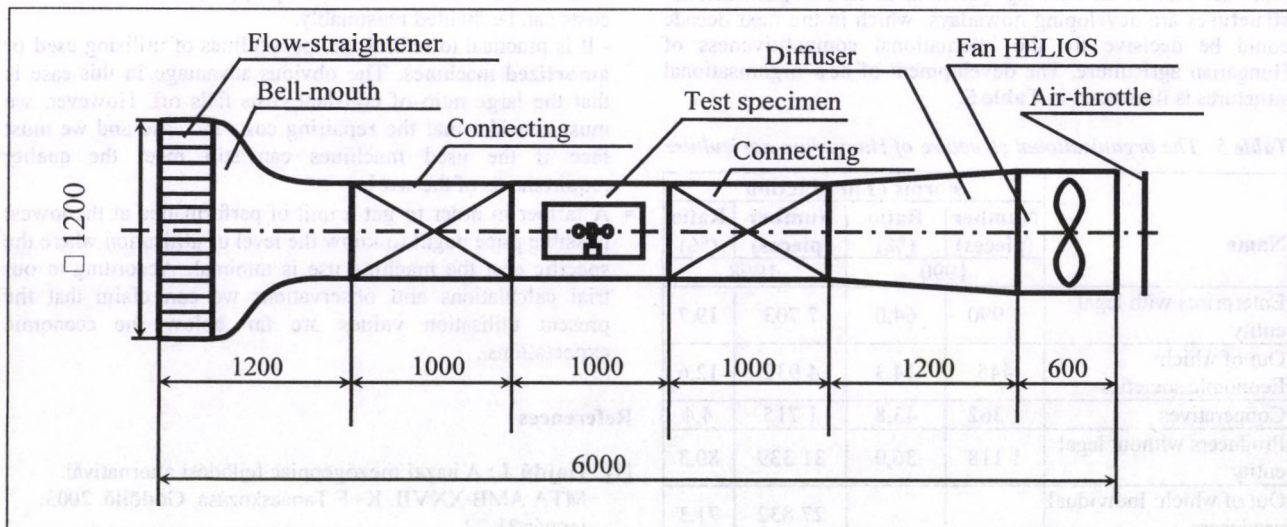

Figure 1
Main dimensions and parts of the wind tunnel
 $n = 0$ to 1440 rpm; $v =$ (cca. 0) 4 to 16 m/s (with throttle)

- 1 instrument type Thies 4.3519.00.000 (assembled with plastic rotor; Figure 4 and 5), and according to the test experiences of this device:
- 3 instruments type Thies 4.3303.22.007 (assembled with metal rotors; Figure 4 and 7).

For the calibration, a differential manometer type Motorola MPX2010DP was chosen (Fig. 4).
 For recording the measurement data, the instrument type SPIDER 8 was used (Fig. 7 and 8).
 The goal of the investigation was to control the correct operation of the instruments.

Elements of the measuring circuit

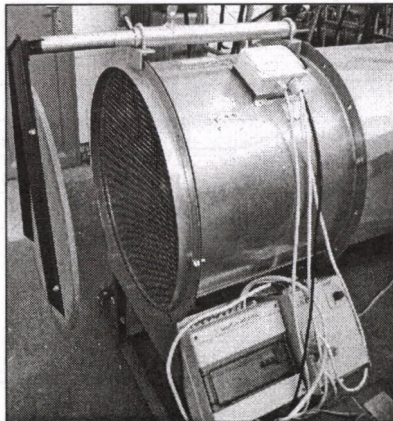

Figure 2
 The HELIOS HQ 630 fan with the frequency converter and the air throttle

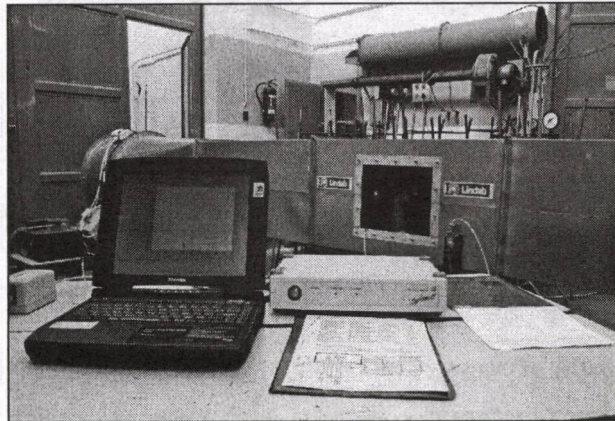

Figure 3
 Measuring circuit

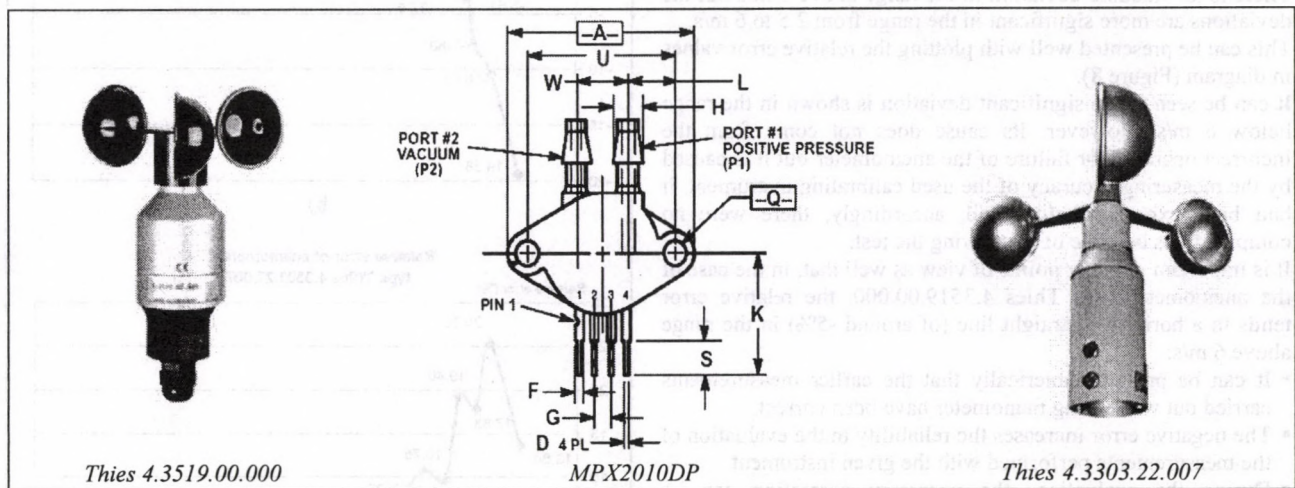

Figure 4
 The tested anemometers and the differential manometer

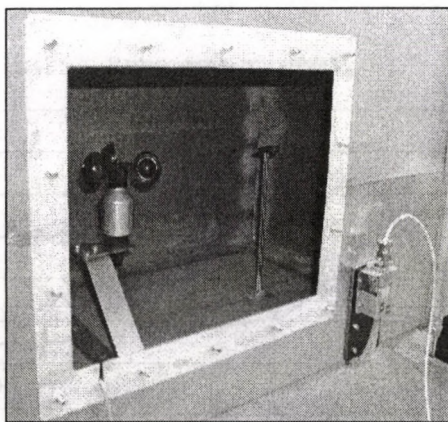

Figure 5
 Anemometer type Thies 4.3519.00.000 in measuring position

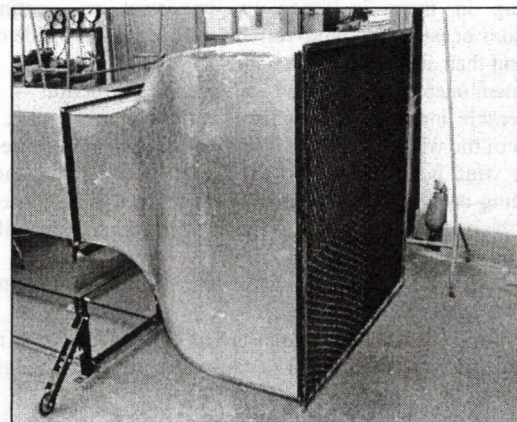

Figure 6
 The bell-mouth entry

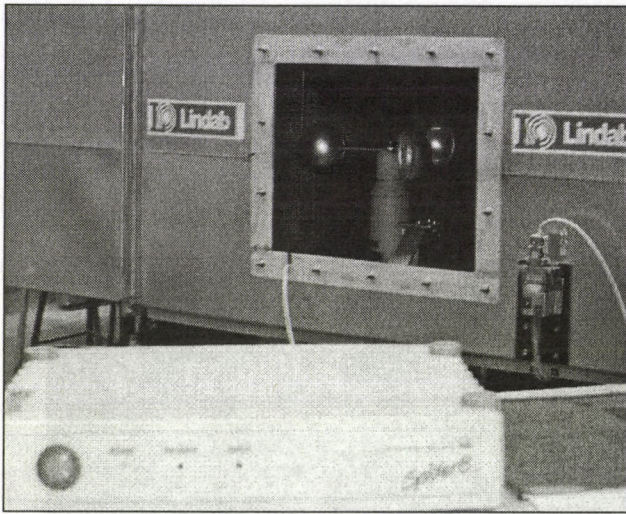

Figure 7
Anemometer type Thies 4.3303.22.07 in measuring position

Evaluation of measurement results

It can be established from the comparison of wind-speed data calculated with the data base measured with the calibrating differential manometer on the tested anemometer that the results can be fit well onto a straight line.

There is no valuable deviation in the range above 6 m/s but the deviations are more significant in the range from 2.5 to 6 m/s.

This can be presented well with plotting the relative error values in diagram (Figure 8).

It can be seen that a significant deviation is shown in the range below 6 m/s. However, its cause does not come from the incorrect operation or failure of the anemometer but it is caused by the measuring accuracy of the used calibrating instrument. It had been expected before and, accordingly, there were no complications because of that during the test.

It is important in many points of view as well that, in the case of the anemometer type Thies 4.3519.00.000, the relative error tends to a horizontal straight line (of around -5%) in the range above 6 m/s:

- It can be proved numerically that the earlier measurements carried out with tilting manometer have been correct.
- The negative error increases the reliability in the evaluation of the measurements performed with the given instrument.
- During the evaluation, the necessary correction can be determined simply.

The exact measurement of the lower wind-speed values and the changing in them is especially important on continental conditions because the wind-variables are less even inside of the continent than at the off-shore winds.

The anemometers – because of their construction – have considerable inertia in comparison with their own mass. The motion of the wind influences it in positive or negative direction i.e. the wind has to start and accelerate or decelerate them – depending on the changing in wind variables – and, moreover, has to overcome the friction of the cup-wheel axle (even if it is little).

It is demonstrated well by the test results of the anemometers having plastic or metal rotors.

It can be seen that the speeding – up of the rotor made of metal is slower and a positive error is caused by this effect (Figure 8 b, c, d).

If its measure is determined and taken into consideration, it will not cause errors in the evaluation of the measurement.

There problems do not arise at the differential manometers because they do not have moving parts and the inertia of the air

column can be negligible and, accordingly, a more accurate momentary value will be given. That is why a calibration instrument operating on this principle was chosen.

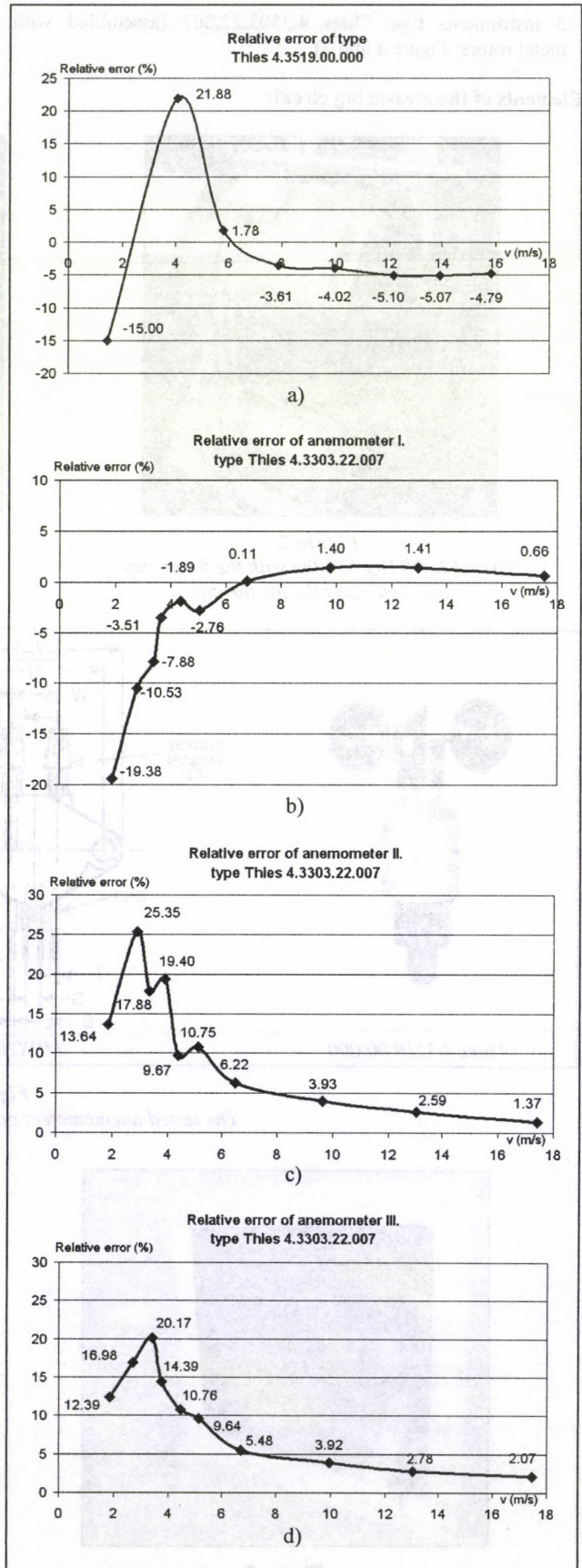

Figure 8
The relative error of the tested measuring instruments

DYNAMIC SURFACE FIRMNESS MEASUREMENT OF HIGH PRECISION

J. Felföldi – A. Fekete – V. Muha
Corvinus University of Budapest

Introduction

The role of the mechanical parameters in the quality assessment of the raw materials of foods – especially in case of fruits and vegetables – is very important. Among these parameters mainly the surface firmness – the mechanical properties of the outer layer of several millimetres depth – is taken into account by the sensory assessment and the traditional hardness measurement methods. If we are searching for an objective measurement method for automatic quality evaluation, classification, providing with a characteristic in a good correlation with the above mentioned properties, it must be quick, non-destructive and suitable for measurement of the hardness of the surface zone. It is obvious to search for a solution among the dynamic firmness measurement methods. The research group of the Physics-Control Department of the CUB is dealing with methodological and suitability investigations the dynamic texture measurement methods (acoustic, drop, impact, wave-propagation etc. methods). According to our experiences and published results, the impact method – applying a low-energy impact onto the surface of the sample with an instrumented hammer fitted with an acceleration or force sensor, and analysing the signal during the contact – seems to be the most encouraging for the described purpose. The resonance and wave propagation methods – characterising the internal texture of the sample – are not suitable for the surface description because of their averaging nature.

According to the previous tests, the impact method is suitable for the measurement of very wide range of fruits and vegetables, but its repeatability is far from the typically very good repeatability of the other dynamic methods. As an example, the results of the repeated impact tests of potato samples are demonstrated on the Figure 1. The impact tests were performed by the same person, in similar circumstances but on different locations of the potato tuber. The weak correlation between the results of the repeated tests is similar to the correlation between the results of the traditional surface firmness measurement methods. During the further investigations our aim was develop a computer controlled measurement system able to precisely repeat the parameters determining the measurement conditions and to use this system for methodological and suitability investigations, to analyse the possible causes of the uncertainty of the results.

Materials and Methods

Different fruits (apple, pear, orange, etc.) and vegetables (potato, onion, tomato, bell pepper, etc.) were used for the methodological investigations, but to avoid the natural biological and time-dependent variability of the samples of horticultural origin, model materials were used as well (firm silicon block, plastic ball of different size to represent the elastic properties with no significant viscosity, foam blocks, etc.).

The base of the impact measurement system reported herein is an impactor arm rotating around a vertical axis with negligible friction. The impactor head of approximately 20 g mass is fitted with a PCB Piezotronics 352B68 acceleration sensor of 105 mV/g sensitivity. The movement speed of the impactor can be adjusted and it can be started by an electromagnetic actuator controlled by the computer. According to our preliminary tests the speed of the impactor is practically constant on its way between 2 cm and 5 cm (related to the start position). The impactor contacts the sample with a changeable tip of different shape and material. A semi-spherical tip made from steel was

used during the test introduced. The system is controlled by a computer. The impactor is started by the computer and the signal of the acceleration sensor is recorded and analysed by a special software developed for this purpose. The impactor arm is pulled back to the starting position after each test. To the investigations taking into account the test position on the samples, a turntable was developed driven by a stepper motor, controlled by the same computer. The minimum step of the table was 1.5°, but during the introduced experiments, it was used with 6° steps (3-4 mm stepping distance depending on the sample diameter).

According to our theoretical approach and experimental results (Felföldi and Ignát, 1999) the ΔT time interval – needed to reach the first peak on the sine-type impact curve – was used for determination of the *impact stiffness coefficient*, d as it follows:

$$d = 1/\Delta T^2, \text{ ms}^{-2}$$

Results and Conclusions

As the first step, the repeatability of the system was tested on different model materials and horticultural samples with strictly uniform impact parameters and positions using repeated impacts in every 10 second. The results for apple sample (2 different positions) are illustrated on the Figure 2. The coefficient of variation of the repeated tests is below 1 % for every tested sample (typically 0.2 – 0.3 %). Conclusively, the repeatability of the system itself can be considered to be very high; the uncertainty experienced in the tests must be caused by the variability of other measurement component.

Therefore the second step was the investigation of the effect of the mechanical moment of the impactor ($m \cdot v$). In a case of a given impactor with given mass, it means the variation of the impactor speed. According to our measurements the moment – which is equal to the integral value of the force by the time – was estimated as the area below the impact curve. According to our interpretation of the impact process – based on the similarity with the harmonic oscillation – in a case of elastic sample, the periodic time of the oscillation, and so the deceleration time (ΔT) does not depend on the impact speed or moment. This simplified approach can be disturbed by taking into account the visco-elastic properties of the samples: increasing impact speed results in an increasing virtual stiffness because of the internal friction. The results of the model materials – investigated as elastic samples – suit the expectations (Figure 3.). Among the horticultural samples the paprika (bell pepper) can be assumed to be pure elastic sample with no significant viscosity. However other products show definite visco-elastic behaviour (Figure 4.). In case of most products tested 10% variation in the impact moment resulted in a 1.5-5% variation in the measured stiffness value. It means that the measurement result can be affected by the uncertainty of the impact speed in case of use of hand-held impact hammer; however the big range of the repetition error cannot be explained only by this component.

The real explanation of this variability and high repetition error can be searched in the samples, that is in the variability of the mechanical properties of the surface layer of the fruits and vegetables. Therefore the distribution of the surface stiffness of different samples was investigated (Figure 5 - Figure 7). The results can be summarised as it follows:

- The variability of the surface stiffness of samples of biological origin is very high (in some cases extremely high). In case of the apple results on Figure 5, shown as an example, the variability of the impact stiffness coefficient is above 16%. Conclusively, the real physical hardness values of the randomly selected positions of the same fruit can be very different.
- The reproducibility of the impact method itself was found to be very good. The correlation analysis of the results of the tests repeated with the very same conditions can be used to detect

small scale mechanical texture changes or to characterise the non-destructive nature of the tests objectively (Figure 6).

- Internal defects or structure can be concluded according to the variability of the surface stiffness measurements (Figure 7).

References

Felföldi, J - T. Ignát (1999) Dynamic method for quick and non-destructive measurement of the surface firmness of fruits and vegetables - Hungarian Agricultural Engineering, 12/1999, pp. 29-30.

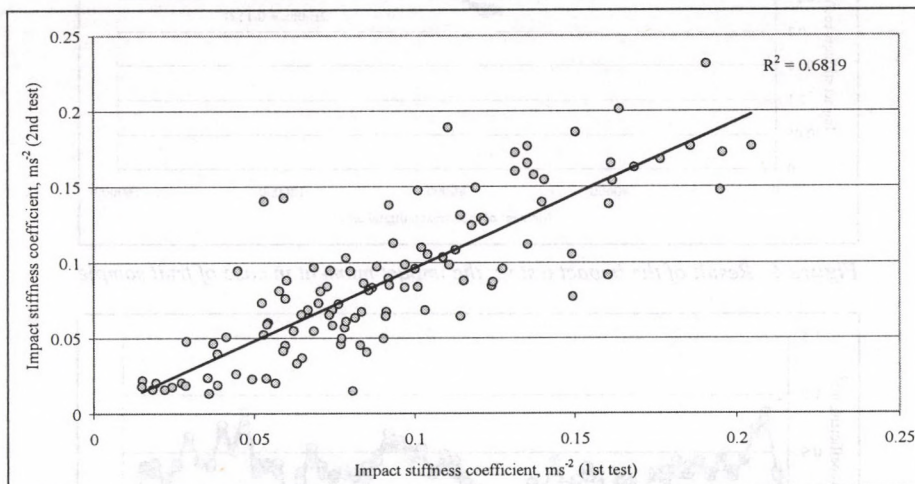

Figure 1 Results of the repeated impact tests on potato samples

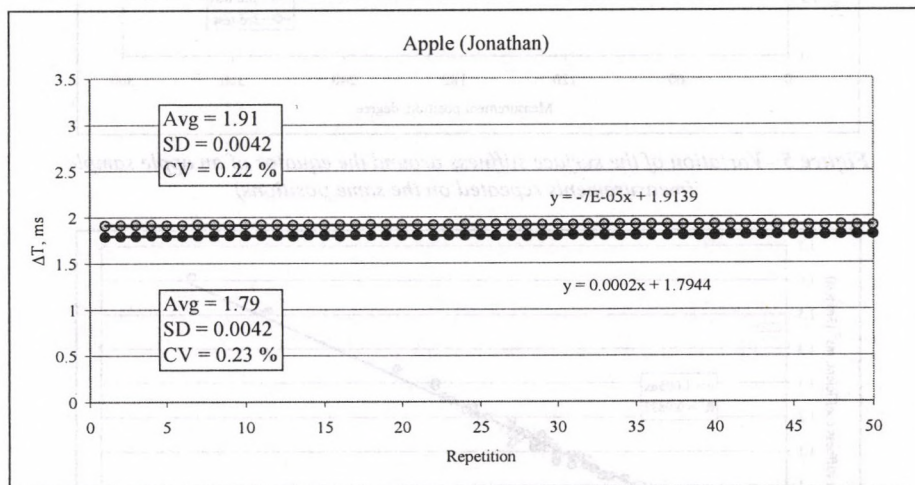

Figure 2 Repeated impact tests of one apple sample (2 positions)

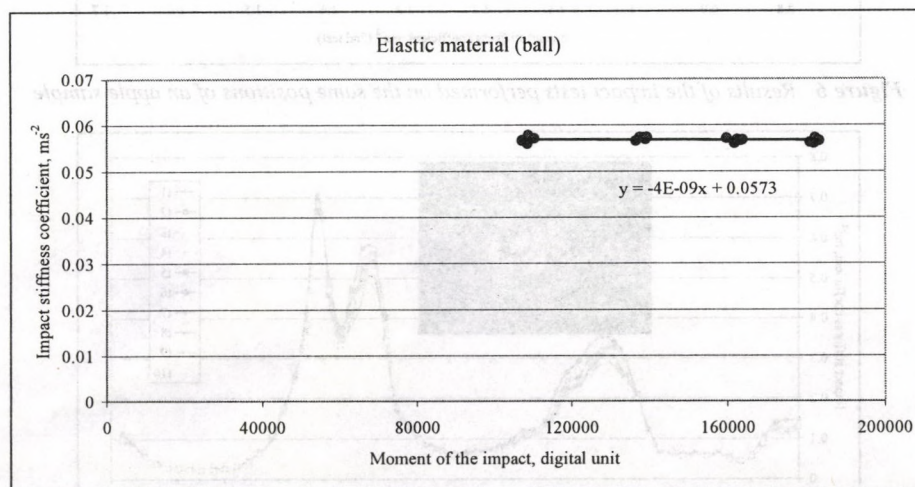

Figure 3 Result of the impact test vs. the impact moment in case of model material

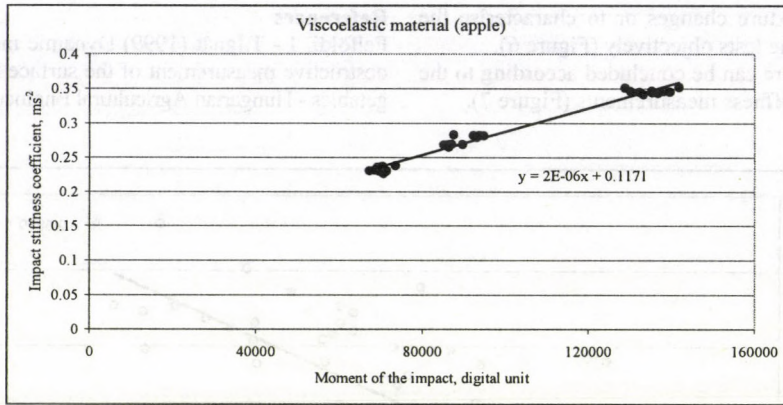

Figure 4 Result of the impact test vs. the impact moment in case of fruit sample

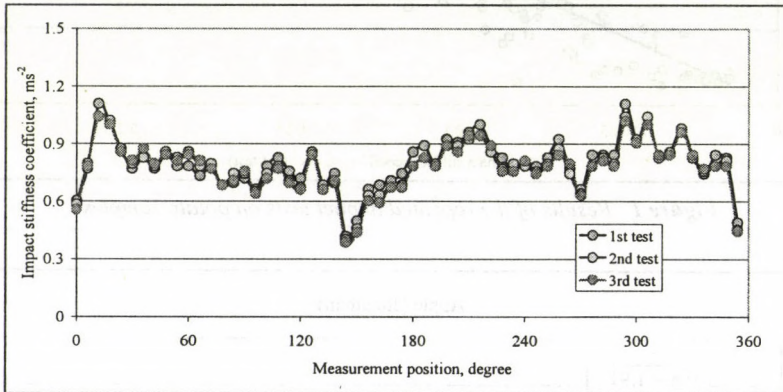

Figure 5 Variation of the surface stiffness around the equator of an apple sample (measurements repeated on the same positions)

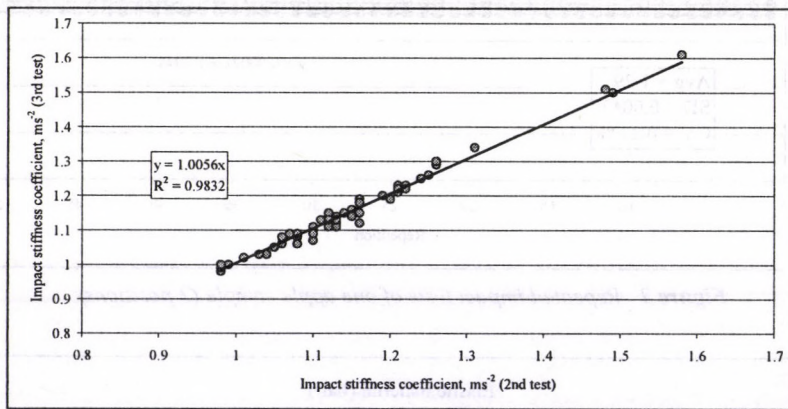

Figure 6 Results of the impact tests performed on the same positions of an apple sample

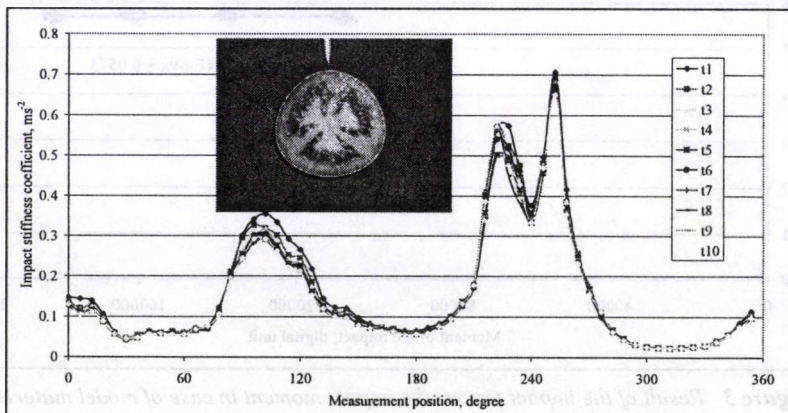

Figure 7 Variation of the surface stiffness around the equator of a tomato sample (measurements repeated on the same positions)

TEXTURE PROPERTIES OF HORTICULTURAL PRODUCE

P. László
Budapest University of Economic Sciences and Public Administration

1. Introduction

The quality of horticultural produce can be determined either by laboratory measurements, or by sensory qualification. Relationship was found between the two methods. Cucumbers and disease resistant apples varieties were tested. The experiments were sponsored by OTKA (TO30241).

First of all the consumers determined sensory points or sensory rank scores. During organoleptical analysis we measured the rheological properties. The sensory evaluation was done by Z. Kókai.

2. Materials and methods

Texture point of preserved cucumber varieties and rank scores of apple varieties were determined. Force and time of biting and chewing are characterized by the organoleptical texture properties. We used penetrometrical texture analysis for laboratory qualification.

In our earlier experimental results the ratio (called limit force-number) of the bioyield and rupture stress of the texture curve is a characteristic of the biting forces as well.

The creep property of chewing is specifically important if the average and standard deviation of the limit force-number will be a probability variable that can be seen in the equation. The 95 percent probability level of this variable is used in agrophysical models.

$$X = \xi \frac{F_x}{F_y} + 2s \frac{F_x}{F_y}$$

The relationship of these interval length and organoleptical properties was defined by creep function with regression analysis.

$$K = \frac{X}{cX + d}; K: \text{texture point}$$

In this function the texture point was used directly by the results of consumers' sensory evaluation. With rank scores before the test of creep-function the quality property (texture point) was defined by PQS method.

3. Results and discussion

The limit force-number of cucumber varieties is smaller in case of bigger organoleptical points as it can be seen in Table 1. The rank scores of apple varieties are shown in Table 2. In the first quarter of the rectangular coordinate system we show the vectors with frequency (number of consumers) of rank scores (can be seen in Figure 1).

We presented PQS method for RESI apple variety in Figure 2. The organoleptical property (organoleptical point) is tangent of the directional angle of centre of gravity. These properties were used in creep-function (can be seen in Figure 3.), which divides into two quality groups the apple varieties (can be seen in Figure 4. too).

4. References

- [1] ZANA-LÁSZLÓ-KRISTÓFNE.(1994) Rheological and sensory evaluation proper-ties of cucumber. The Post-Harvest Treatment of Fruit and Vegetables. Oesterbeek, Netherland. 441-445 p.
- [2] ISO 8587. (1988) Sensory analysis, Methodology, Ranking

Table 1 Connection between stress ratio and the sensory points

Variety	Ratio of limit stresses (limit force-number)	Rate of measuring results in interval		Average of organoleptical point
		Row (%)	Preserved (%)	
Levina	1,2 < μ < 3,5	52		7,4
	2 < μ < 6		56	
Minerva	1,2 < μ < 3,5	97		6
	2 < μ < 6		89	

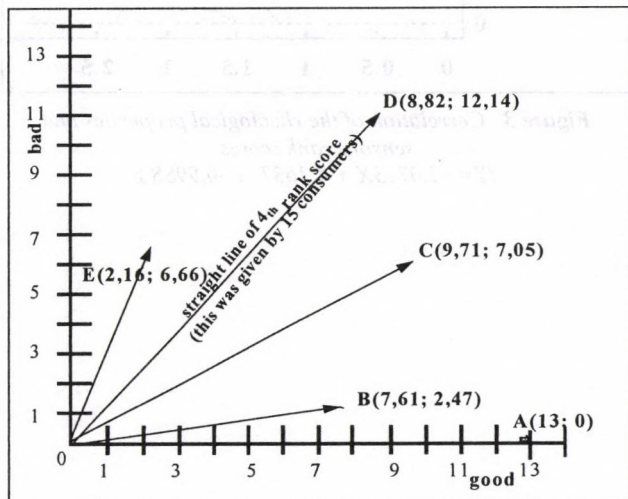

Figure 1 Representation of sensory rank scores with vectors

Table 2 Sensory rank scores of the consumers varieties by varieties

Variety	Number of consumers						Total
	according to rank scores						
	1.	2.	3.	4.	5.	6.	
Rank score							
1. Releika	11	11	10	12	11		55
2. Relinda	17	11	1	11	6	46	92
3. Remo	9	15	10	19	25	14	92
4. Renora	11	10	22	28	15	6	92
5. Resi	13	8	12	15	7		55

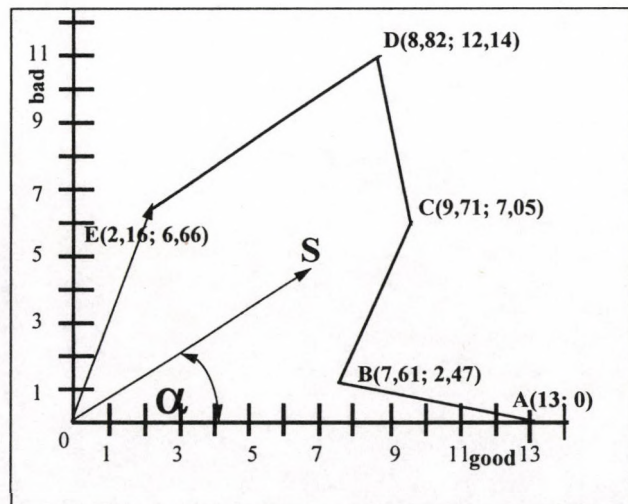

Figure 2 Determination of centre of gravity

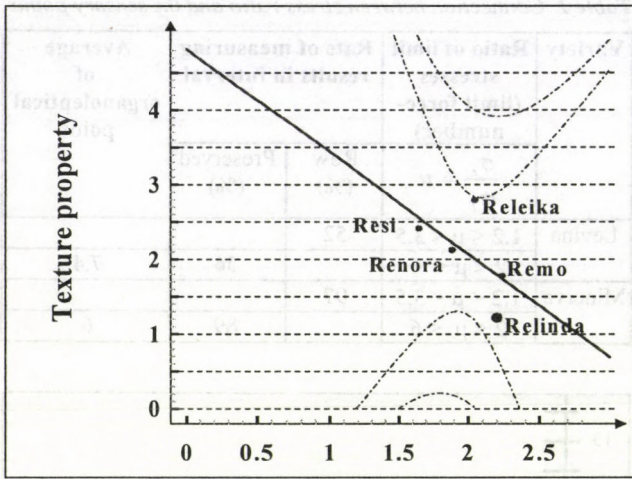

Figure 3 Correlation of the rheological properties and sensory rank scores
 $(Y = -1.0723X + 4.1637, r = 0.9988)$

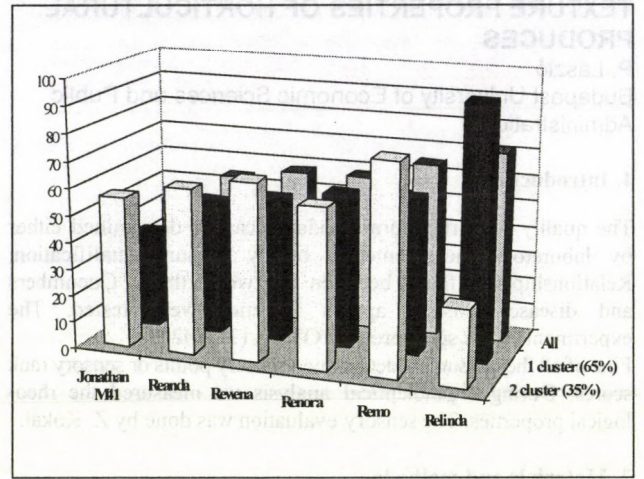

Figure 4 Preference rank of apple varieties

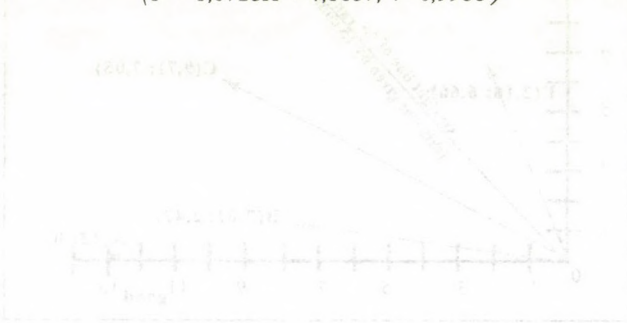

Figure 5 Determination of center of gravity

Variety	Number of consumers according to rank scores				
	1	2	3	4	5
Jonathan	11	10	11	11	11
Rench	17	11	11	11	11
Revena	7	12	12	12	12
Renora	11	10	12	12	12
Remo	13	8	12	12	12

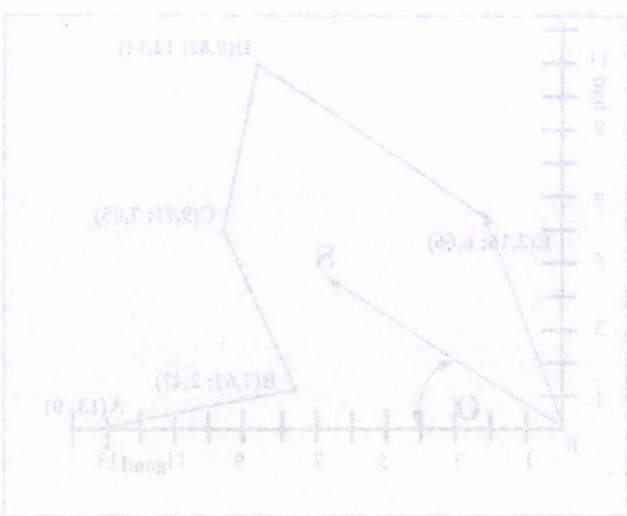

Figure 6 Determination of center of gravity

The first four-number of cucumber varieties is smaller in case of prefer organoleptic points as it can be seen in Table 1. The rank scores of apple varieties are shown in Table 2. In the first quarter of the rectangular coordinate system we show the variety with highest number of consumers of rank scores (can be seen in Figure 1). We present PQ method for RST apple variety in Figure 2. The organoleptic property (organoleptic point) is tangent of the directional angle of center of gravity. These properties were used in organoleptic (can be seen in Figure 3), which studies into two groups the apple varieties (can be seen in Figure 4).

3. Results and discussion

The PQ method of class interval length and organoleptic rank was defined by organoleptic rank with regression analysis.

$$A = \frac{Y}{2Y + X}$$

In this function the output point was used directly by the results of organoleptic sensory evaluation. With rank scores before the test of organoleptic the quality property (texture point) was defined by PQ method.

4. References

- [1] VANA-LAZKO-KRISTOFER (1991) Rheological and sensory evaluation properties of cucumber. The Tech-Hortus Treatment of Fruit and Vegetables. Österreichischer Versuch und Mit-445 p.
- [2] ISO 8587 (1987) Sensory analysis. Methodology. Ranking

CORRELATION BETWEEN THE AGROPHYSICAL CHARACTERISTICS AND STRUCTURE-HARDNESS ON THE WHEAT KERNELS

A. Véha¹ – E. Gyimes¹ – M. Neményi²

¹University of Szeged Faculty-College of Food Engineering

²University of West-Hungary, Mosonmagyaróvár

Introduction and literature review

Wheat is the most important of all the cereals in our country. It is also one of the most valuable and most widely grown crops all over the world. Its popularity is due to the fact that wheat species and varieties can be grown in a wide range of climatic conditions and are highly adaptable. With the exception of the most extreme (tropical, desert and polar) climatic areas it is produced practically everywhere.

By kernel texture we will mainly mean the texture of the endosperm, which is made up of two parts: the aleuron layer and starchy endosperm. The former is a 50-micron-thick layer with high protein content, whose thickness is independent of grain size (EVERS and MILLAR, 2002.) For the sake of simplicity, we will refer to endosperm as the part inside the aleuron layer.

The development of the kernel texture is mainly determined by genetic factors, which can get considerably modified by growing conditions.

Although hardness and vitreousness are related terms, the underlying characteristics are very different. Vitreous, glass-like kernel composition is a feature that any wheat variety can gain provided that the environmental and agronomic conditions are favourable, that is the temperature is optimal and the N supply to the crop is sufficient. Kernel hardness, however, is an inherited genetic feature characteristic of a particular variety.

Kernel hardness depends on the correlation between starch granules and the protein matrix coating them, i.e. the extent of their adhesion. The grinding aspects of soft and hard wheat varieties are different. The starch granules of the former burst out of their protein matrix in the grinding process. In kernels with a hard endosperm texture adhesion force is bigger than the force binding starch particles. This means that it is starch that breaks up in the milling process (BÉKÉS, 2001).

The endosperm hardness of wheat kernels is determined by the Ha gene on chromosome 5D and is responsible for controlling endosperm texture. Genetic research has found it is present in hexaploid (*Tr. Aestivum*) but absent in tetraploid (*Tr durum*) wheat varieties despite the fact that durum wheat varieties are essentially harder. This finding suggests that endosperm texture is determined not by factors responsible for its hardness. On the contrary, it is the genetic set-up coding its softness that should be considered. An investigation of biochemical background revealed it is a 15 kDa-size protein called friabilin (GSP: grain softness protein) that is responsible for softening the binding force between the starch and the protein matrix. LILLEMO (2001) concluded that Puroindulin a (Pin a) and Puroindulin b (Pin b) are the most important genetic factors controlling kernel hardness.

CHANG (1988) discovered there was a correlation between a looser, flourier endosperm and its hardness. FANG and CAMPBELL (2000) arrived at a similar conclusion. Wheat grains with a harder kernel require more energy in the milling process, as indicated by GYIMES and VÉHA (1998), VÉHA and GYIMES (2000). PUJOL et al. (2000) examined energy consumption during milling and established that the correlation between kernel hardness and grinding energy demand was medium strong and positive.

It is equally important to know the sizes of the kernels in order to make the control of post-harvest technologies precise. The high quality and technological efficiency of sifting before drying, sorting before storage can mainly be achieved if the size

of the sifter is right. This can only be done if we are familiar with the sizes of the wheat grain. Wheat grains develop into different sizes in their ears. This sheer fact makes it essential to determine the sizes and distribution of the kernels in the post-harvest operations. The size and the shape of the seed are two of the natural characteristics that make the species and possibly the variety of the wheat identifiable. CSIZMAZIA et al. 1994, CSIZMAZIA and NAGYNÉ P.I. (1996) investigated the size-related physical and aerodynamic properties of seeds. The role of physical characteristics is of crucial importance in the drying process. Besides size, size distribution – homogeneity – and mass density should also be emphasized. (BEKE, 1997) **Kernel weight** and, analogously, thousand-kernel-weight indicate the volume of the yield to be expected. According to LELLEY (1967) high thousand-kernel-weight is one of the keys to good productiveness. As far as crops grown on the same site are concerned it is their kernel weight and not the number of ears that is predominantly inherited. Based on the correlation between flour yield and thousand-kernel-weight WIERSMA et al. (2001) carried out experiments with aestivum wheat kernels to produce varieties with high thousand-kernel-weight. The role of **density** was investigated by DOBRASZCZYK et al. (2002), CHANG (1988), FANG and CAMPBELL (2000). To measure density, we need to consider mass density first, where the gas (air) volume among kernels is measured together with the volume of the kernels. In literature mass density is often referred to as volume weight, although in physical sense it can be regarded as density. This latter characteristic is an indicator widely used and greatly emphasized in the milling practice and is called **hectolitre weight (HLW)**. Low hectolitre weight often indicates less flour yield (KELLY et al. 1995), this in itself being a bad omen for milling industry, and to some extent it can also be a prognosis for the quality of flour to be expected. Hectolitre weight depends on several factors like kernel size, the rate of damaged kernels (GAINES et al. 1997), shape and inner texture. GULER (2003) pointed out that it is the effect of irrigation - among others - in the production technology that contributes to the increase of HLW. SCHULLER et al. (1995) refer to the correlation between hectolitre weight and soft or hard kernel texture in their work. GAINES et al. (1997) proved the correlation between kernel size and damage, largely influenced by the weather conditions during ripening, and hectolitre weight. They also emphasized the necessity of sorting out shrivelled wheat grains. Although the so called **true density** is an important feature of agricultural materials, it is not frequently investigated and is hardly referred to. This could be the reason why, in the lack of extensive experience, it is impossible to gather relevant information on how density values change. NEMÉNYI (1988), however, investigating corn hybrids found that density and the rate of chemical components were correlated.

Aims of investigation

Kernel hardness is a factor of high importance when wheat varieties grown for human consumption – either the common (*Triticum aestivum*) or durum (*Triticum durum*) – are assessed for quality by the milling and flour processing industries. The solid or loose nature of endosperm texture determines the category of the wheat in terms of inner content. Thus hardness is a variety-specific measure of value and also a price maker.

The hardness or softness of wheat kernels will basically determine the technology, the course and the economical nature of the milling process. In our study we aimed to focus on determining kernel hardness and establishing the characteristics of kernel texture.

Material, methods and means

The wheat varieties used in the study were provided by Szeged Cereal Research Non-Profit Company (Szegedi Gabonater-

mesztési Kutató Kht). They were grown in Táplánszentkereszt, Fülöpszállás, Zombó and Szeged and harvested in the years 1999-2002. The preparation of representative samples, which were cleaned after harvest (to remove dust and large impurities) was made with a "chess-board" sample distribution method.

The **kernel size** was measured in the following way: 100 kernels were examined in all three sizes with the help of a digital slide-gauge. The resolution of the measuring gauge was 0.01mm and its precision 0.03mm. A table of the measured data was then drawn up, and the data assessed.

Thousand-kernel-weight (TKW) was established according to norm MSZ 6367/4. A certain amount (approximately 500 kernels = 20 g) was taken from the samples, then measured with an accuracy of up to 0.01 and the weight of the sound kernels was calculated in proportion to 1000 kernels.

Hectolitre weight (HLW) is the weight of one hectolitre of crop as measured with a purpose-made authenticated measuring device. HLW was measured according to norm MSZ 6367/4. The weight of 1 litre (1dm³) of wheat was measured with special crop-quality scales. Following this, hectolitre weight was calculated by means of a conversion chart.

To determine **kernel hardness (HI: Hardness index)** the PERTEN SKCS 4100 measuring instrument was used. This instrument measures not only HI value but also kernel weight and moisture content and provides an average value for 300 kernels measured one by one. Samples were measured in 3-3 parallel tests, respectively.

Flour yield is the rate of flour extraction in proportion to wheat volume in laboratory conditions. Another definition of flour yield is the volume of all the actual milling products in proportion to the wheat volume milled under given (commercial) milling conditions. The distinction between the two is made to avoid misinterpretation. Wheat grains were **milled in a laboratory** by means of the Brabender Quadromat Senior laboratory mill. Flour is produced in laboratory conditions to determine the flour yield of wheat varieties, also known as extraction. The device has four main structural units: sifter, body, 3 pairs of break rolls and three pairs of reduction rolls. With its fixed roll arrangement and roll gaps it represents an extremely short milling technology. It can reach a 65-75% flour yield in theory.

Test results

The samples were divided into two internationally accepted types: the samples **within the range of HI 50** are considered **HARD**, while those within HI 50 are **SOFT**. (see Fig. 1)

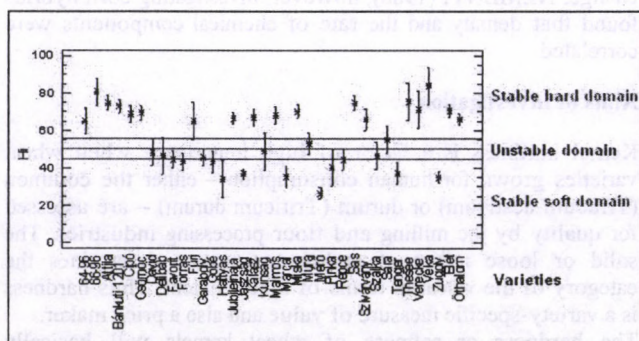

Figure 1 Kernel hardness stability of wheat varieties in 1999-2002. (n=173)

The assessment of varieties well reveals the differences between hard and soft samples. But when it comes to classification, difficulties might arise with the assessment of such varieties as DÁVID, DÉLIBÁB KUNSÁG or MURA. Hardness is not a stable variety-specific characteristic of these wheat varieties.

These varieties are highly sensitive to changes in the weather or the environment.

In **above average growing seasons**, when both precipitation and temperature are sufficient and the site suits the demands of the variety, the original variety-specific features will prevail and **kernel hardness value will be high**. Under **worse conditions**, however, the genetic qualities of the variety do not show up and **kernel texture will be looser and softer**. It should be noted that the hardness of the kernel texture is generally an inherent, stable quality of most varieties (GYIMES et al. 2002).

Dividing the samples into hard and soft classes we compared the measured and calculated weight values separately. The difference with soft samples was 10% approximately ($R^2=0.809$), while the difference proved bigger, almost 17% in the case of hard samples with an excellent determination coefficient ($R^2=0.815$). Our results suggest that the furrow depths of hard and soft kernel varieties differ. Based on this finding we set up a multi-variable equation, which made it possible to estimate **thickness measurement** safely. Estimating equations for hard and soft varieties, respectively, are as follows:

For hard varieties (HI ≥ 50):

$$Th = 2,927 - 0,206 * l + 0,029 * TKW (R^2=0,63)$$

For soft varieties (HI < 50):

$$Th = 2,588 - 0,166 * l + 0,031 * TKW (R^2=0,72)$$

where Th : thickness (mm)

TKW: thousand-kernel-weight

l: length (mm)

The values of hectolitre weight (HLW) and those of the **porosity (ε)** of the calculated set are inversely proportional (SITKEI, 1981). This correlation is substantially influenced by the hardness of kernel texture. This is proven by the following estimating equations:

For hard varieties... (HI ≥ 50)..

$$\epsilon = 0,722838 - 0,00403237 * HLW (n=105, R^2=0,72, r = -0,850)$$

For soft varieties (HI < 50)

$$\epsilon = 0,672659 - 0,00344793 * HLW (n=59, R^2=0,66, r = -0,811)$$

The correlation between kernel hardness and flour yield was tested with samples from 36 different locations, harvested in 2002. Our findings prove that there is a **positive correlation** between kernel hardness and flour yield, as shown in Fig 2. The medium strong correlation proves the advantages of hard varieties and predicts economical, high-performance milling.

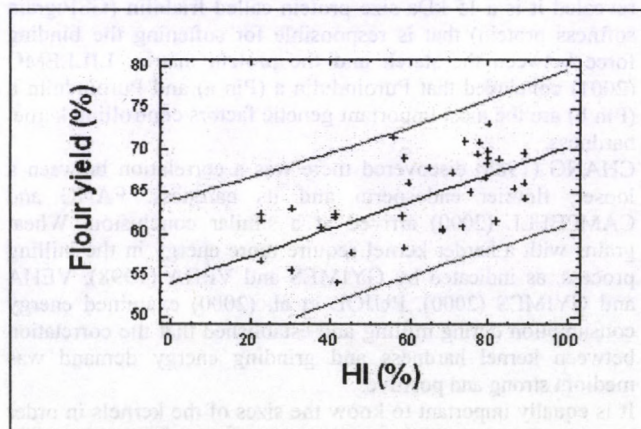

Figure 2 Correlation between kernel hardness and flour yield (n=36; r=0.36)

We managed to further increase the accuracy of estimating flour yield. The following linear equation in two variables based on **kernel hardness** and **width size** supports a strong and significant positive correlation between the estimated and measured values of milling:

$$\text{Flour yield} = 3,40979 + 15,8725 \cdot W + 0,174489 \cdot HI$$

$$(R^2=0,5424, n=36, r=0,734)$$

Where W: width size of wheat grains (mm)

HI: Hardness Index value of wheat samples (%)

Acknowledgements

The authors would like to thank the management of the Wheat Division of Szeged Cereal Research Non-Profit Company (Szegedi Gabonatermesztési Kutató Kht. Búzaigazgatóság) and János Matuz general manager for putting true to variety wheat samples at our disposal.

Summary

Despite the fact that the three characteristic of wheat kernel measurements (length, width, thickness) are considered to be independent, thickness measurement can be estimated with good accuracy by a two-variable model, set up from length and thousand-kernel-weight values. This leads us to a verified correlation, which, however, is significantly modified by kernel hardness. For soft kernel samples the value of the determination coefficient ($R^2 = 0.72$) is higher than for hard kernel ones ($R^2 = 0.63$) but the relation is still **significant and strong** in both cases.

We also found that the relation between hectolitre weight (HLW) and porosity basically depends on kernel hardness. The constant of the linear regressive equation can be regarded as quasi equal, however, the difference between the regressive coefficients appeared to be ca. 15%, where correlation was identical. Thus the shape of wheat varieties with hard kernel texture is more suited to fill a given volume.

The efficiency of the flour milling process can best be measured by the volume of the end-product, that of the flour produced from a given volume of wheat. We measured the correlation between hardness index and flour yield (laboratory mill) and it proved to be significant and medium strong ($r=0.63$). We managed to further increase the accuracy of our estimates based on kernel hardness values by applying new background variables. Width turned out to be a suitable physical dimensional characteristic, thus enabling us to set up an estimating equation in two variables. As a result, width and hardness index values made estimating extraction more accurate. The estimate line and the laboratory flour yield are strongly correlated ($r=0.734$)

References

[1] Beke, J. (1997): A szemes termények szárítása (in szerk Beke: Terményszárítás, Agroinform Budapest, pp9-419)
[2] Békés, F. (2001): A búza endospermium szerkezetének szerepe néhány minőségi búzát termelő országban. (in szerk Bedő, Z. :A jó minőségű, keményszemű búza nemesítése és termesztése, p. 25-34)

[3] Chang, C. (1988): Measuring density and porosity of grain kernels using a gas pycnometer. Cereal Chemistry, Vol. 65. No.(1), p. 13-15
[4] Csizmazia Z. - Nagyné. P. I. - Kasza F.(1994): The Determination of Physical Characteristics of Seeds for the Construction of Seeding Machines. Hungarian Agricultural Engineering, Vol. , No. 7.p. 63-66
[5] Csizmazia, Z. - Nagyné P. I (1996): Búza vetőmag fizikai jellemzői, mozgása levegőben. XXVI. Óvári Tud. Napok, p. 946-952 p.
[6] Dobraszczyk, B. - Whitworth, M. - Vincent, J. - Khan, A. (2002): Single kernel wheat hardness and fracture properties in relation to density and the modelling of fracture in wheat endosperm. Journal of Cereal Science, Vol. 35, No (3), p. 245-263
[7] Evers, T. - Millar, S. (2002): Cereal grain structure and development: Some implications for quality. Journal of Cereal Science, Vol. 36., No. 3, p. 261-284
[8] Fang, C. - Campbell, G. (2000): Effect of measurement method and moisture content on wheat kernel density measurement. Food and Bioproducts Processing, Vol. 78, No (C4), p. 179-186
[9] Fang, C. - Campbell, G. (2000): Effect of measurement method and moisture content on wheat kernel density measurement. Food and Bioproducts Processing, Vol. 78, No (C4), p. 179-186
[10] Gaines, C. - Finney, P. - Andrews, L. (1997): Influence of kernel size and shriveling on soft wheat milling and baking quality. Cereal Chemistry, Vol. 74, No. 6, p 4-10
[11] Guler, M.(2003): Irrigation effects on quality characteristics of durum wheat. Canadian Journal of Plant Science, Vol 83, No. 2, p. 327-331
[12] Gyimes, E. - Véha, A. (1998): New method for the determination of wheat hardness. 45.th Research Review Conference, USDA ARS - AACCCincinnati Section Wooster, Ohio, USA
[13] Kelly, J. - Bacon, R. - Gbur, E. (1995): Relationship of grain-yield and test weight in soft red winter-wheat. Cereal Research Communacation, Vol. 23, No. 1-2, p. 53-57
[14] Lelley, J. (1967): A fajtakérdés és a magyar búzafajták. Mezőgazdasági Kiadó, Budapest p. 2-127
[15] Neményi, M. (1988): Energiatakarékosan szárítható kukoricahibridek jellemzői, Akadémiai Kiadó, Budapest, p.5-88
[16] Pujol, R. - Letang, C. - Lempereur, I. - Chaurand, M. - Mabilille, F. - Abecassis, J. (2000): Description of a micromill with instrumentation for measuring grinding characteristics of wheat grain. Cereal Chemistry, Vol. 77, No. 4, p. 421-427
[17] Schuler, S. - Bacon, R. - Finney, P. - Gbur, E. (1995): Relationship of test weight and kernel properties to milling and baking quality in soft red winter wheat. Crop Science, Vol. 35, No. 4, p. 949-953
[18] Sitkei, Gy. (1981): Mezőgazdasági anyagok mechanikája, Akadémiai Kiadó, Budapest p. 11-461
[19] Véha, A - Gyimes, E. (2000): Determining Kernel Hardness Through the Granulometric Parameters of Grinding. Hungarian Agricultural Engineering, Gödöllő Vol. 13, No. 1, p. 29-31.
[20] Wiersma, J. - Busch, R. - Fulcher, G. - Hareland, G. (2001): Recurrent selection for kernel weight in spring wheat. Crop Science Vol. 41, No. 4, p. 999-1005
[21] Hungarian Standard (MSZ 6367/4.)

DETERMINATION OF THE NUMBER AND THE PLACES OF SUGAR-BEET RECEIVING REPOSITORIES

J. Benkő – P. Soós – Zs. Szüle – A. Balogh
Szent István University, Gödöllő

1. Introduction

The number of the factories and the needed capacity of the Hungarian beet industry is determined by the EU's production quota, that Hungary won in December 2002. The factories are not interested in producing more or producing less sugar than the amount of the quota, arranged during the connection treaty, because the overflow can only be exported at a very low price outside EU, while producers can lose valuable opportunities on the market if they produce below quota.

It is well-known that sugar-beet production is one of the most paying in field growing, so people who have the right to transport sugar-beet form a very privileged group, hard to get in. The privilege and the earning is derivable from the EU's guaranteed minimal sugar-beet price that will expectably be 11-12 thousand HUF/tonn. The interventional price of sugar is 155-170 HUF/kgs and the factory price is 180-195 HUF/kgs, depending on the market-rate of the Hungarian Forint. These prices let reaching higher profit than now, either in sugar-beet growing and in sugar producing too.

But it would be irresponsible to do nothing and neglect further developments after having the quota. On one hand the EU's reformation of the sugar market is expected to aim the increased defeatment of the differences between countries by competitiveness. This results that the sugar-beet production shifts to the regions that can produce more effectively and the less effective areas will have to decrease or even terminate their production. On the other hand the profit that can be realized from the production is not only depending on the income, but it depends on the costs too, so the aim of the developments or at least a part of them must be about cutting the costs.

This study only investigates a narrow field of the developments, the actions after lifting of the sugar-beet, moreover from the point of view of transportation and transportation costs.

2. The current practice of sugar-beet transportation

The collection of sugar-beet from the fields can be direct (uniarticulate) or combined (polyarticulate). According to the experience in the past, the costs of loading, storing, cleaning and transportation from the field to the receiving station were paid by the factory, independent from the type of the transportation.

In case of direct transportation the sugar-beet gets to the factory from the field without takeover, by road-vehicles. This solution can be seen on the left side of Figure 1 (alternative 1.). The receiving station is the factory itself, where the sugar-beet is cleaned and clamped after the qualitative and quantitative acceptance. The advantages of this solution are: adaptability, no need for takeover. But the high amount of contaminants (soil, furrow-weed residues, etc.) that can get inside the factory is a disadvantage, because the storage and removal of these materials increase the costs.

One way of the combined transportation is (Figure 1, alternative 2.) when the farmers take the sugar-beet on road-vehicles to the forwarding railroad-station, from where in the second phase of transportation, the material gets to the factory by railroad. During this process, the sugar-beet is cleaned with mobile or stationary machines, before or after the road transportation. The receiving station here is also the factory. The mechanical cleaning of the sugar-beet that comes on railway is hard to carry out, so they put the material from the carriage right into the

factory's cleaning system, from where it goes to production in 12-24 hours. (Wet storage is not allowed, while the autolysis of sugar on the wet surfaces is very strong, because of the raised activity of micro-organisms. Further problem is that the washed dirt means huge load to the factory's sewer.)

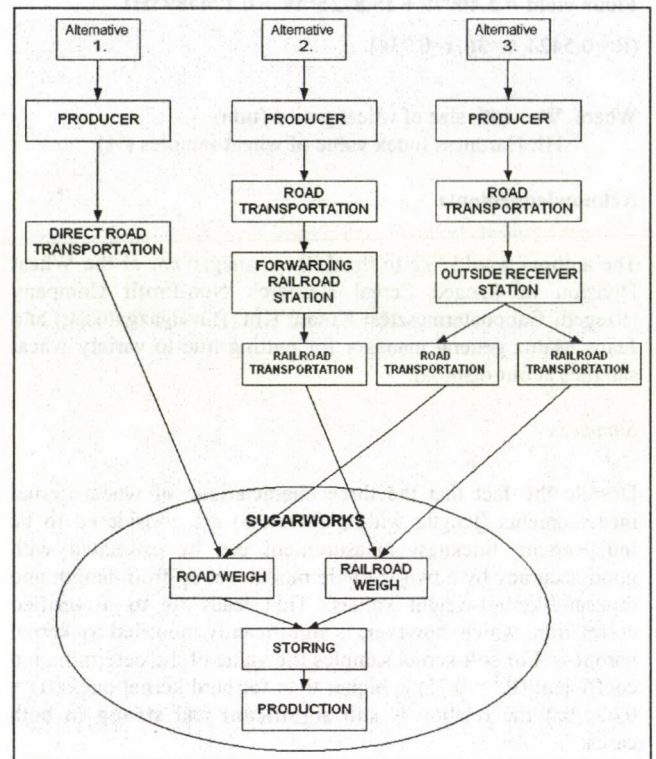

Figure 1 Former solutions for transporting between fields and sugarworks

The third solution (Figure 1., alternative 3.) is when producers transport to the outside receiver station on public road. After the qualitative and quantitative acceptance of the sugar-beet, before the temporary and quantitative acceptance of the sugar-beet, the factory owned cleaning and clamping machines, operating at the station do the necessary procedures. The transportation right to the factory can be done on public road or on railroad, depending on the receiver station's traffic connections. This procedure could let the accepted sugar-beet to put it right into production, because of it's cleanness. But the build-up of the public road receiver stations do not let the same, hence the sugar-beet coming from these receiver stations, after the repeated cleaning the sugar-beets often mix with the carriages that come from public road, according to alternative 1. Because of the repeated cleaning, the rate of the broken beets is the highest in these carriages.

3. Loading and transporting by enhanced ceaning

Way of transportations written above have advantages and disadvantages that we represented without mentioning all of these. However there is a fourth method that is called enhanced cleaning by the profession and that is putting all of the advantages of the above mentioned methods together. The body of it is that they transport the sugar-beets on public roads to the storing repositories, where they are clamped and then a high-performance (150-450 tonns/hour), self-propelled, so-called cleaning-loader machines clean and put the raw material to the public road vehicles. The treated sugar-beet transported into the factory can be processed immediately after the qualitative and quantitative acceptance. The advantages of enhanced cleaning: the amount of the contaminants (soil, furrow-weeds, etc.) that can get inside the factory is minimal, so there is need to care

about their storage and treatment. The transporting costs decrease, because less weight must be transported into the factory and there is no need to transport the contamination. The floating-water and cleaning-water consumption decreases, that cuts back the costs of water handling and cleaning. The decrease of the contamination in the carriages increases the objectivity sugar-beet grading and it also decreases the margin of errors in measurements. It is an environment-friendly procedure that fits for the more and more strict environmental rules.

Not only the above mentioned advantages motivate the establishing of the method, but the guaranteed, minimal EU price of sugar-beet paid to the farmers that contains the cost of the transportation between the field and the repository, the clamping, the cleaning and the loading. The transportation cost between the repository and the factory would still be paid by the sugarworks. This means that the interest of the sugarworks is to have repositories that are easily accessible, as close to the factory as it is possible. This is a bit different from what the producers want.

It can be easily conceded that the most sensitive point of the establishing is choosing the place, the number and the size of the sugar-beet repositories. When assigning the place of a repository it is a basic term to the warehoused sugar-beets to be easily transported to the factory in case of extreme weather circumstances too and transportation does not endanger the continuous operation.

Setting the optimal place of repositories (that needs the least transporting costs) is currently very difficult, because the lack of agricultural road-network with concrete surface. The only solution to the problem is evolving the concrete surfaced roads between the existing agricultural roads and the optimally set repositories. These costs would fall on to the producers and the sugarworks. (A good example is the Sugarworks in Kaba, where the factory and the farmers jointly invested to built repositories, linked directly to the concrete surfaced road network within an 'Agricultural road and repository building' program.)

The size of a certain clamp is depending on the operating, the capacity of the cleaning-loader machine, the size of the served field and on the danger of freezing. Different cleaning-loaders need different sizes of repositories built. Machines fed with loaders can be used at any size of clamps. Machines that have own pick-up boards need 6-8 m wide clamps. Small clamps can be built by special transporting vehicles and in favourable cases they can be directly built with the bunkered harvest machines. In case of conventional transporting with trailer a particular loading machine is needed. When using small clamps the danger of freezing is higher than can be avoided with covering.

4. Establishing the optimal place of repositories

The establishing of the optimal place of a repository is a so-called multidivisional and two-step depot exploring problem, where the repositories with unknown co-ordinates and the sugarworks with known co-ordinates are the centers, and the sugar-beet fields are the served depots. First step of transportation is between the fields and the repositories, the second step is moving between the repositories and the sugarworks.

In the problem the capacity of the served depots (fields) and the co-ordinates of the field centers are known. Capacity can be calculated from the size of the area and from the yield. The number of repositories equals to the number of cleaning loaders. Although the loaders are movable, it seems to be suitable to use the precept of one loader per repository. The capacity of the repository is defined by the performance (180-220 tonns/hour) of the loader. According to the experiences a loader can clean 100 thousand tonns of sugar-beet a season, that means it can serve 1700 hectares of field, based on a 60 tonns/hectare yield.

Sugarworks are centers with unusual characteristics, because not even their capacities, but their co-ordinates are also known. The questions that need to be answered are the followings: Where to put the repositories? How to set up areas, that is to which repository to transport from the certain sugar-beet fields? Based on the above mentioned things, the condition system and the objective function of the mathematical model that can solve the problem is the following:

- (1) $X_{ij} \geq 0, Y_{ik} \geq 0$, where $i=1,2,\dots,n, j=1,2,\dots,m, k=1,2,\dots,l$
- (2) $\sum_j X_{ij} = t_j$
- (3) $\sum_j X_{ij} \leq f_i$
- (4) $\sum_i Y_{ik} \leq r_k$
- (5) $\sum_j t_j \leq \sum_i f_i$
- (6) $\sum_j t_j \leq \sum_k r_k$
- (7) $Q = \sum_{i,j} X_{ij} \sqrt{(x_j - u_i)^2 + (y_j - v_i)^2} + \sum_{i,k} Y_{ik} \sqrt{(\xi_k - u_i)^2 + (\eta_k - v_i)^2} \rightarrow \min$

Where n is the number of repositories, m is the number of the sugar-beet fields, l is the number of sugarworks, X_{ij} is the amount transported from field j to repository i , Y_{ik} is the amount transported from repository i to factory k , t_j is the capacity of field j (equals to the yield of the field), f_i is the capacity of repository i , r_k is the capacity of repository k , f'_i is the amount transported to repository i , $r_i(u_i, v_i)$ are the co-ordinates of repository i , $r_j(x_j, y_j)$ are the co-ordinates of field j , $r_k(\xi_k, \eta_k)$ are the co-ordinates of sugarworks k , Q is the transportation work.

The solution of the object is to set up areas from the sugar-beet fields and to find the centerpoints of the certain repositories. This means we lead back the problem to single area problems.

The first step of the solution is to make areas, that means classifying each field to a certain repository. The simplest way to that is to use a so-called combinations chart (chart 1.) in which c_{ij} is the distance between repositories (D_i) and sugar-beet fields (T_j), d_{ij} is the distance between repositories (D_i) and factories (G_k) and (t_j) is the capacity of the field, (f_i) the repositories and (r_k) the factories.

Combinations chart

	T_1	T_j	T_m	D_1	D_i	D_n		Bound
D_1	c_{11}	c_j	c_{1m}	M	M	M	\leq	f_1
D_i	c_{i1}	c_j	c_{im}	M	M	M	\leq	f_i
D_n	c_{n1}	c_j	c_{nm}	M	M	M	\leq	f_n
G_1	M	M	M	d_{11}	d_{1i}	d_{1n}	\leq	r_1
G_k	M	M	M	d_{k1}	d_{ki}	d_{kn}	\leq	r_k
G_l	M	M	M	d_{l1}	d_{li}	d_{ln}	\leq	r_l
f_j	t_1	t_j	t_m	f'_1	f'_i	f'_n		
	k_1	k_j	k_m	k_1	k_i	k_n		

The elements of matrix c_{ij} can be counted by:

$$c_{ij} = \sqrt{(x_j - u_i)^2 + (y_j - v_i)^2},$$

and the elements of matrix d_{ki} can be counted by:

$$d_{ki} = \sqrt{(\xi_k - u_i)^2 + (\eta_k - v_i)^2}.$$

For this we take the starting co-ordinates of the repository $r_i(u_i, v_i)$ discretionarily before the first iteration.

For the making of the areas, similar to the *Vogel-Korda* method, we figure differentials to every column (k) that are the differences of the two smallest elements of the column.

First we complete the making of the areas in the D_i-T_j partition, that means first we order the sugar-beet fields to the repositories. We start programming in the column, where the difference is the biggest. We place the biggest amount possible (X_{ij}) onto the smallest element of the column and we continue programming with the column that's difference is the next in the row. We eliminate the rows and columns where there are no more elements left. When eliminating a row, we have to calculate the differentials again. We have to take care not to exceed the given upper bounds (f_j).

After ordering the sugar-beet fields and the repositories to each other, we calculate the amounts transported into the repositories by using the formula:

$$\sum_j X_{ij} = f'_i, \quad i=1,2,\dots,n$$

We fill in the results to the chart and we complete the making of areas in the G_k-D_i partition also by using the method described above.

After setting up the areas, each area can be examined as individual, single area problems. This way the places of the centers $r_i(u_i, v_i)$ can be determined by using the iterative formulas of the center-investigation beside co-ordinates. The iterative formulas of the center-investigation beside co-ordinates in area i are:

$$u_i^{(k+1)} = \frac{\sum_j X_{ij} x_j / c_{ij}^{(k)}}{\sum_j X_{ij} / c_{ij}^{(k)}}$$

$$v_i^{(k+1)} = \frac{\sum_j X_{ij} y_j / c_{ij}^{(k)}}{\sum_j X_{ij} / c_{ij}^{(k)}}$$

where $c_{ij}^{(k)} = \sqrt{(x_j - u_i^{(k)})^2 + (y_j - v_i^{(k)})^2}$, and k is the number of iterations.

After every iterational step we investigate the following conditions:

$$|u_i^{(k+1)} - u_i^{(k)}| \leq \varepsilon,$$

$$|v_i^{(k+1)} - v_i^{(k)}| \leq \varepsilon$$

Where ε is an arbitrarily small number. We finish the iterational process if the conditions are fulfilled, otherwise we go on working with the method.

We make a new combinational chart from the new center co-ordinates ($r_i(u_i, v_i)$) and we put the sugar-beet fields again into new areas. The method finishes when two combinational charts lead to the same areas, two times over. Note that the success of the method is highly depending on the determination of the starting values. It can happen that we only get local position of minimum. We can avoid this by calculating several times with different starting values. We can only be satisfied if we get the same results with different center series.

The final results tell us the co-ordinates ($r_i(u_i, v_i)$) that mark the optimal places of the repositories (D_i), the effective capacity of the repositories (f'_i), the sugar-beet fields (T_j) belonging to the repository i and the repositories that belong to the sugarwork k .

Preferences

- [1] J. Benkő: Logistic planning (With agricultural applications) - Logisztikai tervezés. (Mezőgazdasági alkalmazásokkal) Dinasztia Kiadó, Budapest, 2000. 199 p.
- [2] B. Fischer: The position and the challenges of our department. Sugar industry - Ágazatunk helyzete, kihívásai. Cukoripar, LVI évfolyam, 2 szám, 2003. április-június, 54-55 p.
- [3] J. Füzy: The directions of machinery improvement and the efficiency in sugar-beet harvesting - Gépesítés fejlesztési irányok és hatékonyság a cukorrépa betakarításban. Cukoripar, LII évfolyam, 2 szám, 1999. április-június, 76-80 p.
- [4] J. Kondás: Logistic procedures at the Agricultural Directorate of Szerencs Sugarworks Corp. - Logisztikai folyamatok a Szerencsi Cukorgyár Rt. mezőgazdasági igazgatóságánál. (Szakmérnöki diplomaterv), GATE, GTK. Vállalatgazdálkodási Szakmérnöki Szak, Gödöllő, 1998.
- [5] L. Szilágyi: Loading with enhanced cleaning in practice at Kaba Sugarworks Corp. - A fokozott tisztítású rakodás gyakorlata a Kabai Cukorgyár Rt.-nél. Cukorrépa termesztési és termeltetési tanfolyam. Cukoripari Egyesülés, Budapest 2001. 104-107 p.

Contents of N° 17/2004

FIELD RESEARCH FOR INVESTIGATION OF TILLAGE-INDUCED CO₂ LOSS

- I. J. Jóri¹ – J. Rádics¹ – I. Pazsiczki² – I. Szabó² – Cs. Gyuricza³
¹Budapest University of Technology and Economics
²Hungarian Institute of Agricultural Engineering, Gödöllő
³Szent István University, Gödöllő 12

COMPARISON TEST OF POWERSHIFT AND CONTINUOUSLY VARIABLE TRANSMISSIONS

- Zs. Farkas – Gy. Kerényi
 Budapest University of Technology and Economics 15

INFLUENCE OF THE FRONT AXLE SUSPENSION TO THE TRACTOR TRACTION CHARACTERISTICS

- M. Szente¹ – Zs. Kassai¹ – H. Lampel² – F. Handler²
¹Non-profit Co. of HIAE for QT., Gödöllő
²BLT, Austria 18

PLANT-PERCEIVING SPRAYING MACHINE IN ORCHARDS

- Gy. Dimitrievits – Z. Gulyás – L. Kovács – L. Magó
 Hungarian Institute of Agricultural Engineering, Gödöllő 21

ENVIRONMENT FRIENDLY APPLICATION, TESTS OF DRIFTING INFLUENCED BY WEATHER CONDITIONS AND PROCEDURE

- A. László¹ – B. Pályi¹ – M. Lönhárd¹ – Mrs. A. László²
¹VU GFA Department of Agricultural Engineering and Farm Mechanisation
²VU GFA Department of Chemistry and Microbiology 24

FORCE-BASED ATOMIZATION THEORIES FOR SPRAY NOZZLES

- I. Sztachó-Pekáry
 College of Kecskemét 26

PLANT PROTECTION IN LINE WITH CONSUMER AND ENVIRONMENTAL PROTECTION

- H. Ganzelmeier
 Federal Biological Research Centre, Braunschweig 29

IMPROVING GERMINATION AND WATER ADDITION PARAMETERS OF SEEDS WITH ELECTROMAGNETIC TREATMENT

- L. Bense – E. Joó – P. Szendrő – Gy. Vincze
 Szent István University, Gödöllő 35

ON ISSUES OF FOOD – SAFETY OF MILK HANDLING BY MICROWAVE

- K. M. Lukács – P. Sembery
 Szent István University, Gödöllő 38

SIMILARITY THEORY OF STRUCTURED AGRICULTURAL FLUIDS

- L. Bense – E. Joó – P. Szendrő – Gy. Vincze
 Szent István University, Gödöllő 41

MECHANICAL FEATURES OF AGRICULTURAL PACKAGING FOILS

- A. Csátár – Z. Bellus – L. Csorba
 Hungarian Institute of Agricultural Engineering, Gödöllő 44

HEAT TREATMENT OF THE MIXED FODDER

- J. Csermely – M. Herdovics – Gy. Komka
 Hungarian Institute of Agricultural Engineering, Gödöllő 47

POSSIBILITIES OF REDUCING EMISSIONAL ENVIRONMENTAL LOAD IN PIG HOUSING

- I. Pazsiczki¹ – W. Berg² – L. Ducza³
¹Hungarian Institute of Agricultural Engineering, Gödöllő
²Institute of Agricultural Engineering Bornim (ATB)
³TSF College of Agricultural Sciences, Mezőtúr 51

SUMMER CLIMATIC PARAMETERS IN MODERN FREE BOX STABLE

- J. Vegrícht¹ – P. Hutla¹ – M. Češpiva¹ – J. Bak² – L. Fenyvesi² – I. Pazsiczki²
¹Research Institute of Agricultural Engineering, Prague
²Hungarian Institute of Agricultural Engineering, Gödöllő 54

NEW RESULTS IN THE FIELD OF RADIO-FREQUENCY IDENTIFICATION

- L. Tóth – L. Fogarasi – N. Schrempf
 Szent István University, Gödöllő 57

THE PHYSICAL CHARACTERISTICS OF HEMP SEED

- Z. Csizmazia, Z. – N. I. Polyák
 Centre of Agricultural Sciences University of Debrecen 60

EXAMINATIONS OF FALSE HEARTWOOD FORMING IN BEECH TREE BY MEANS OF COMPUTER-TOMOGRAPH

- B. Biró¹ – J. Rumpf² – G. Bajzik³ – R. Garamvölgyi³ – Zs. Petrás³
¹Forestry and Wood Corp. of Somogy, Kaposvár
²University of West-Hungary, Forestry College, Sopron
³Diagnostics and Onkoradiology Institute of the University of Kaposvár 63

ANALIZATION OF THE POSSIBILITIES OF BASIC MATERIAL SUPPLY OF WOOD-BASED POWER PLANTS WITH USING FORESTRY INFORMATIONAL DATABASE

- B. Marosvölgyi – L. Jung, PhD. stud. – J. Kovács
 University of West-Hungary, Sopron 65

COMPONENT ANALYSIS OF PARTICLES OF RESIDUES ORIGINATING FROM CNC MILLING MACHINES CORRELATION WITH THE MILLING PARAMETERS

- M. Varga – E. Csanády – G. Németh, PhD. Stud. – Sz. Németh, PhD. Stud.
 University of West-Hungary, Sopron 68

DETERMINATION OF THE ROLLING RADII IN THE INTERACTION OF A PNEUMATIC TYRE AND DEFORMABLE SOIL

- P. Kiss
 Szent István University, Gödöllő 71

WHY IS THE MECHANISATION OF HUNGARIAN SMALL AND MEDIUM SIZE FARMS SO DIFFICULT?

- I. Husti
 Szent István University, Gödöllő 74

CONTROLLING OF ENERGETIC WIND MEASUREMENT (CALIBRATION OF CUP ANEMOMETERS)

- N. Schrempf – L. Tóth
 Szent István University, Gödöllő 76

DYNAMIC SURFACE FIRMNESS MEASUREMENT OF HIGH PRECISION

- J. Felföldi – A. Fekete – V. Muha
 Corvinus University of Budapest 80

TEXTURE PROPERTIES OF HORTICULTURAL PRODUCES

- P. László
 Budapest University of Economic Sciences and Public Administration 83

CORRELATION BETWEEN THE AGROPHYSICAL CHARACTERISTICS AND STRUCTURE-HARDNESS ON THE WHEAT KERNELS

- A. Véha¹ – E. Gyimes¹ – M. Neményi²
¹University of Szeged Faculty-College of Food Engineering
²University of West-Hungary, Mosonmagyaróvár 85

DETERMINATION OF THE NUMBER AND THE PLACES OF SUGAR-BEET RECEIVING REPOSITORIES

- J. Benkő – P. Soós – Zs. Szüle – A. Balogh
 Szent István University, Gödöllő 88

Contents of the
“Mezőgazdasági Technika”
 periodical of the year 2004.

MEZŐGAZDASÁGI
TECHNIKA
 2100 GÖDÖLLŐ, TESSEDIK S.U.4.

N° 1	
Animal identification by electronics (L. Tóth – N. Schrempf – L. Fogarasi).....	2
Bogballe EX trend, the „Profi” winner (M. Nagy).....	5
Machines and equipment for potato store-house (J. Fűzy).....	21
More novelties from the AGRITECHNICA 2003 (J. Hajdú).....	32
New tyre development for tractors (G. Antos).....	36
N° 2	
Anti-drifting nozzles (Z. Gulyás – L. Kovács).....	2
Animal identification by electronics Part II. (L. Tóth – N. Schrempf – L. Fogarasi).....	4
Agro+Massexpo - special edition.....	15
Field trip at KASZ-COOP Derecske (G. Dávidházy).....	52
Four-wheel driven tractors (Gy. Kománci).....	56
Operational cost of agricultural machinery in 2004 (L. Gockler).....	60
N° 3	
Agro+Massexpo 2004 (A. Horváth – G. Pálincás).....	1
The effective operation system for combine harvesters (D. Faust – A. Szaxon).....	2
AGROMEK 2004 – The novelties of cattle and hog production systems (G. Peresztegi – J. Bak).....	15
The ballasting system of the tractors Part II. (M. Szente – Zs. Kassai).....	23
Certification of agricultural machines – the touchstone of qualitative mechanization in China as well (L. Fenyvesi – M. Szente – Gy. Tátrai).....	32
The trading data of agricultural machinery in 2003. (J. Hajdú).....	40
Machinery development for sugar-beet harvesting (J. Fűzy).....	44
N° 4	
Examination of the temperature layering at hotwater-boilers with upper and lower feeding (A. Zachár).....	2
Conference of Bavarian and Hungarian experts on cost-saving forms of the utilization of agricultural machines (I. Nagy).....	6
Mechanical fertilizer-spreaders (Zs. Kassai).....	23
CNH - American grand tractors from St. Valentin (J. Hajdú – A. Horváth).....	32
AXIÁL Professional Days in Lajosmizse (A. Horváth – G. Pálincás).....	36
Agro+Massexpo 2004, Part II. (A. Horváth – G. Pálincás).....	38
N° 5	
Effect of the control of the input-side of a turbocharged dieselmotor to the change of the characteristic curves of the motor (P. Bánszki – R. Varga).....	2
John Deere Brasil (J. Hajdú).....	6
The development and the environment contacts of the mechanized irrigation (A. Cserhidy).....	21
Novelties of the exhibition TECHAGRO Brno (A. Horváth).....	36
The mission of the domestic manufacturers in the machinery-supply of the agriculture (J. Hajdú).....	40
N° 6	
Baling of agricultural and communal waste for energetic purposes (Cs. Fábrián – Zs. Pap).....	2
Development of tractors in China (J. Hajdú).....	6
Round balers (Zs. Kelemen).....	21
The agriculture of Brasil from the aspect of a mechanician (A. Horváth).....	32
Operating data of agricultural machines in the practice (L. Gockler).....	35
Fliegl-jubilee in Abda (A. Horváth).....	38

N° 7	
Analyse of the frictional forces of an pneumatic actuator (Zs. Bartus – J. Wigner).....	2
„Europa” plant production day in Leipzig (A. Horváth).....	6
Utilisation of renewable energy sources according to a survey of the EU-requirements (L. Tóth – N. Schrempf – G. Tóth).....	23
Cyclorama of the tractor-market in West-Europe (J. Hajdú).....	32
Uncertainties and reflections at the stubble-field cultivation (M. Birkás).....	39
The national strategy for the development of the agrarium and the rural area is ready (L. Gockler).....	42
N° 8	
Measurement of friction forces in an air cylinder (Zs. Bartus – Sz. Árgyelán).....	2
The CAP 10 – a pledge of the future (I. Jóri J.).....	4
The active participation of research and development in the agricultural production – the system of the market-conscious technological development (L. Fenyvesi).....	6
Spike and power rotary harrow (I. Jóri J.).....	27
Uncertainties and reflections at the stubble-field cultivation – Part II (M. Birkás).....	46
The economy of the wind-energy in the USA (D. Jován).....	50
N° 9	
Kinetic and dynamic analyse of inertial shaker (Z. Láng).....	2
Multi-purpose carrier from Gomel (J. Hajdú).....	6
Storing and Manipulation of onions – Part I. (F. Jakovác).....	21
Machines of the Kverneland-Group in practice (A. Szűcs).....	30
Uniform European training of the managers of Machinery Rings (I. Nagy – Gy. Tátrai).....	35
The world-market of tyres (J. Hajdú).....	40
N° 10	
International Farmer’s Days in Bábolna (A. Horváth – G. Pálincás).....	1
Novel methods in the logistic of sugar beet (J. Benkő – P. Soós).....	2
Tillage 2004 – Soil tillage show in England (M. Birkás – G. Bogdán – J. Lajtos).....	12
Storing and manipulation of onions (F. Jakovác).....	23
Continuous development at Fendt (A. Horváth).....	38
N° 11	
Turbine-viscosimeter for measurement of the stream-characteristics of agricultural sludges (A. Szász – P. Szendrő – Gy. Vincze – L. Bense).....	2
New John Deere combine harvesters of the series „i” (intelligent) (Gy. Hajmássy – G. Nagy – I. Sörös).....	4
Presentation of new Claas-tractors in Hungary (A. Horváth).....	14
Picker-husker (Zs. Kelemen).....	21
International Farmer’s Days in Bábolna (A. Horváth – G. Pálincás).....	33
The effect of the change of regime on the agriculture (L. Gockler).....	40
N° 12	
Economic comparison of the mechanized potato-production on ridge and on bed (L. Magó – J. Fűzy).....	2
Development trends in the animal keeping (L. Tóth – N. Schrempf).....	5
Novelties of the exhibition EIMA 2004 in Bologna (J. Hajdú – Gy. Tátrai).....	14
Solutions of power transmission on tractors – I. (Zs. Kassai – P. Bánszki).....	21
Novelties in the product-offer of Massey Ferguson (A. Horváth).....	32
The prices for energy are going to increase, let us direct more attention to the energy management! (L. Gockler).....	38

Do you want to know more from
Hungarian Agriculture Machinery!

SENDTMS ORDER FROM TO:

The Hungarian Agricultural Machinery Journal
H-2001 Gödöllő, Tessedik Sámuel u. 4.

ORDER FORM

I want order the Hungarian Agriculture Machinery Journal
from day month 200.....

The subscription fee: 3240 HUF

Name:

Adress:

Code, City:

Country:

Date: day month 200.....

.....

signature

