

**HUNGARIAN**

*Review*

**AGRICULTURAL**

**ENGINEERING**

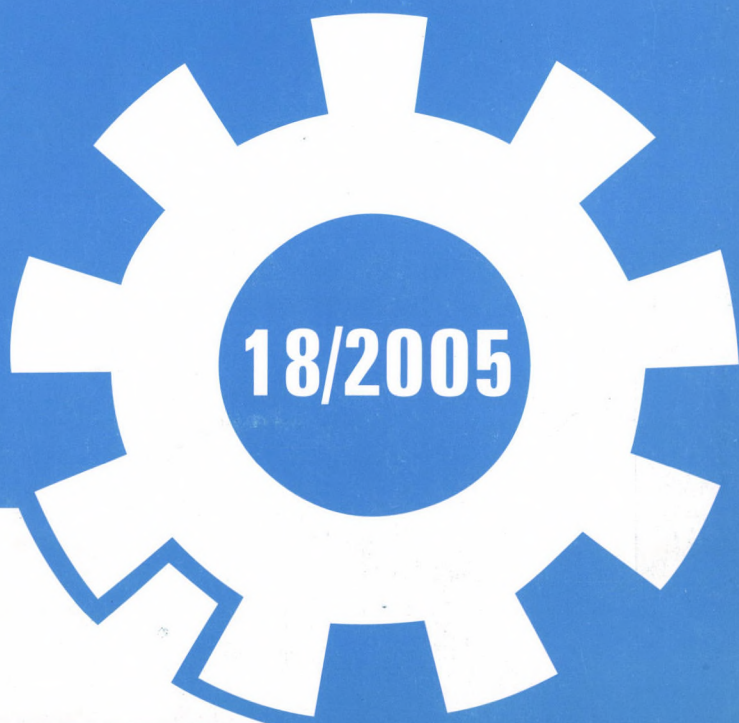

1825

100  
100  
100



# Hungarian Agricultural Engineering

N<sup>o</sup> 18/2005

PERIODICAL OF THE COMMITTEE OF  
AGRICULTURAL ENGINEERING OF  
THE  
HUNGARIAN ACADEMY OF SCIENCES

*Editor:*

**Prof. Dr. László TÓTH**

*Editorial Board:*

Dr. Jenő CSERMELY

Dr. Imre DIMÉNY

Dr. István J. JÓRI

Dr. László FENYVESI

Dr. Péter SEMBERY

Dr. László TÓTH

Dr. János BEKE

Dr. Zdenek PASTOREK,  
*Czech. Republik*

Dr. Jürgen ZASKE,  
*Deutschland*

Dr. Vijaya G.S. RAGHAVAN,  
*Canada*

Dr. Bart SONCK,  
*Belgium*

Published by

**Hungarian Institute of Agricultural Engineering**

H-2100 Gödöllő, Tessedik S. u. 4.

Director: Dr. László FENYVESI



**St. István University, Gödöllő**  
**Faculty of Mechanical Engineering**

H-2103 Gödöllő, Páter K. u. 1.

Dean: Dr. János BEKE



Gödöllő, December, 2005



## PREFACE

The Agricultural Engineering Board of the Hungarian Academy of Sciences which supervises the development of this branch organises annually a conference at Gödöllő, which is the central place of the Hungarian agricultural scientific activity.

During the sessions, research scientist, developing engineers, experts of institutions engaged in agricultural engineering development strong in numbers the organizer, the hungarian universities and other higher grades of education, the research institutions: Hungarian Institute of Agricultural Engineering at Gödöllő, Faculty of Mechanical Engineering of the St. István University at Gödöllő and foreign guests give account of their results obtained in the research work and development of agricultural machinery.

This yearly English-Language publication the "Hungarian Agricultural Engineering", started at 1988, contains selected papers presented at the conference of 2005. We do hope that this publication will be found interesting to a big part of agricultural engineers.

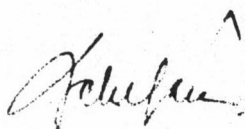

**Dr. János Beke**  
Dean

Faculty of Mechanical Engineering  
St. István University

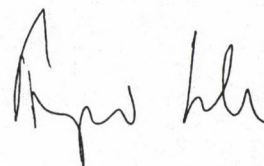

**Dr. László Fenyvesi**  
Director

Hungarian Institute of Agricultural Engineering  
Gödöllő



## **PART I.**

### **ABSTRACT OF SELECTED PAPERS**

## COMPLEX COMPARISON OF TRACTOR TRANSMISSION SYSTEMS BETWEEN CONTINUOUSLY VARIABLE TRANSMISSION AND POWERSHIFT TRANSMISSION

Zs. Kassai – M. Szente

Non-profit Co. of the MGI for Quality Testing, Gödöllő

The main exercises are to ensure maximum power (i.e. cultivated area, transporting power) and agro technical and optimal working speed at tractor-implement aggregate operation.

Significant points are minimizing of costs and specific fuel consumption. This needs to ensure harmonized connection between the tractor engine and characteristics of transmission system at working points on field.

Application of gear ratio of continuous variable transmission and their centralized control together gives several advantages for the agriculture. For that reason we measured more tractor transmission systems for operating advantage in last years.

The result of quick and accurate computer programming is perfect corresponding between engine and Continuously Variable Transmission system. It is absolute conform together the engine speed and gear ratio to situation, travel speed and load. In this way achievable the followings: optimal fuel consumption, minimal exhaust, economical and designable operation.

## NEW METHODS OF FRUIT TREE SPRAYING

Gy. Dimitrievits<sup>1</sup> – Z. Gulyás<sup>1</sup> – L. Kovács<sup>1</sup> – P. Sallai<sup>2</sup>

<sup>1</sup> Hungarian Institute of Agricultural Engineering, Gödöllő

<sup>2</sup> Pomological Research and Consulting Non-Profit Company, Újfehértó

During the examinations, besides the spraying machines equipped with axial ventilators, the standard KERTITOX BORA 2000 and the KERTITOX BORA 1000 for intensive plantations, we studied the KERTITOX 600 spraying machine, as well, which is equipped with a linear spraying structure and a axial ventilator. We also examined the KERTITOX BORA 2000 plant detector spraying machine with infra red and ultra sound systems. The range of the coverage on both sides of the leaves was the lowest in the case of the standard KERTITOX BORA 2000, where the achieved values of 1,1-1,9, compared to other examined machines, are quite good results. In the case of the linear KERTITOX BORA 1000 machine the range 1,4-2,6 can also be considered good. The low air capacity KERTITOX 600 machine's result 1,6-2,8 can also be acceptable considering the fact that the spraying in the next row significantly decreases the ratio of coverage on both sides of the leaves. By applying the infra red plant detector device we had a spray solution saving of 28,1-55,3%. By applying the ultra sound plant detector device, the spray solution saving altered between 49,8 and 68,4%.

## EFFECT OF THE DRYING PROCESS ON THE CHARACTERISTICS OF THE CORN BATCHES

J. Csermely – M. Herdovics – A. Csátár

Hungarian Institute of Agricultural Engineering, Gödöllő

Object of the OTKA (T 037-214) assisted researches are to determine the aggregation characteristics of the corn in the course of drying. Examinations are carrying on with three selected varieties of corn under laboratory and operative circumstances. Examinations contain among others the analysis of the bulk mass and density depending on the moisture content and the shrinkage of grain by the effect of moisture abstraction. The examinations covered the determination of the compressive stress connecting with the humidity, specific compression strain, elasticity modulus and pressure work.

## DEVELOPMENT OF LEAKAGE CONTROLLED FLOW DIVERSION SAFETY VALVE

E. Forgács – J. Csanádi – C. Hodúr – G. Szabó

Faculty of Food Engineering, University of Szeged

The strict instructions for heat-treating of raw milk are contained in Codex Alimentarius Hungaricus, 92/46, 92/380 EU Directives and 1/2003 (I.08) FVM-ESzCsM decree. Most of the applied equipments for heat-treating of raw milk have no flow direction valve, which should guarantee the heat-treating of milk by directives in all cases.

The goal of the project: to develop a safety flow-diversion valve for small and medium dairy firms in order these firms will be able to satisfy the EU directions, in this way, their products can take part in the Eu dairy market as well

Developed flow-diversion valve fitted small pipe diameter has double valve seat and leakage system.

The main advantage of developed valve is the follows: the raw milk or failure heat-treated milk doesn't able to flow into the regenerative sections of equipment in the case of the failure of gaskets, even more it shows the gasket failure with leakage.

Using equipments with developed valve cancel a main critical point from the Quality Management System. Innovated valve is quickly installable with standard binder items.

The flow-diversion safety valve, which was developed by Zootechnika Ltd. and University of Szeged, sponsored by EU and Hungarian National Program GVOP 3.1.1-2004-05-0275/3.0. has a Qualification from Bundesanstalt für Milchwissenschaften Institut Kiel n:KI-S 5/04.

## MICROWAVE TREATMENTS OF LIQUID FOOD

J. Kiss – P. Sembery

Szent István University, Gödöllő

The accession of Hungary to the European Union launched a lot of important development in the food industry. The growing market did not only result in the expansion of supply and the appearance of new products but it also created intense competition. Food quality and safety have become more significant in primary food processing. Meeting the requirements of both quality and safety is a very important step to the success in the EU. The application of microwave energy in preservation processes – for example in the pasteurization of liquid food products – may provide a great tool to meet those requirements. Significant improvement may be achieved by the innovation of traditional methods and by making use of the advantages (internal heat production, quickness) that microwave technology may provide.

This paper focuses on introducing the possible use of microwave energy in pasteurization processes (implementation, etc.). It also concentrates on looking for the opportunities to reduce costs of operation and to improve the quality and the safety of food.

**Keywords:** microwave, pasteurization, temperature, food quality

## DETERMINATION OF THERMAL PARAMETERS UNDER INDUSTRIAL CONDITIONS

F. Eszes – R. Rajkó – G. Szabó

Faculty of Food Engineering, University of Szeged

The measurement and evaluation of industrial heat penetration curves can help at CAD design of heat transfer because the thermal parameters (e.g. thermal diffusivity) can be determined from it. We investigated the heat treatment of meat products with the Ball method, finite series solution of Fourier differential equation, calculation of thermal parameters from chemical composition and using robust regression. The obtained results were compared with calculation of finite difference

method taking into account the temperature dependence of thermal diffusivity. In the course of our investigation we experienced that using robust regression reduced the standard deviation of determination. So the overestimation can be avoided. Although the Ball method using more simplification presumptions is more robust than the infinite series solution, the role of the measurement errors can be hardly cleared out. The initial and boundary conditions and the placement error of temperature sensor influence the value of thermal diffusivity. Its fluctuation caused rather by the temperature development than by the convection and denaturation. The assumption of the infinite large surface heat transfer coefficient resulted often unrealistic large thermal diffusivity values. The thermal diffusivity values deriving from methods dealing with the thermal diffusivities as constant and from chemical composition taking into account the average temperature of the process were close together. The temperature curves calculated with finite difference method taking into account the temperature dependence of thermal diffusivity proved the acceptability of the obtained results.

### **GEOMETRIC AND AGRO-PHYSICAL CHARACTERISTICS OF WINTER WHEAT VARIETIES**

E. Gyimes – A. Véha  
Faculty of Food Engineering, University of Szeged

This study presents the results of the authors' investigations into winter wheat varieties in the years 2000 - 2002. They tested the values of kernel size, kernel and mass density, porosity and also how kernel hardness changes in kernel hardness. Kernel size is noticeably influenced by the year the crop is harvested in, the main contributor being precipitation, first of all. Kernel hardness values reveal a similar tendency.

It was established that kernel hardness is related to several agro-physical characteristics. Investigations suggest that the inverse proportion between hectolitre weight and porosity is greatly influenced by the quality of endosperm texture, i.e. kernel hardness.

### **EFFECT OF SAMPLE SHAPE AND SIZE ON MEASURED IMPEDANCE SPECTRUM**

E. Vozáry – P. Mészáros  
Budapest Corvinus University, Faculty of Food Science,  
Department of Physics and Control

Magnitude and phase angle of electrical impedance of apple and potato samples with different shape and size were measured with an HP 4284A precision RLC meter in frequency range of 30 Hz – 1 MHz. The length of gold plated copper electrode pins was 5 mm. The measurements were performed with different electrode distances. A correction for the electrode polarization was calculated and the impedance of biological tissues was evaluated. The value of phase angle was practical independent from the size and shape of sample and the magnitude of impedance increased as the size of sample decreased.

### **DRYING CHARACTERISTICS OF DIFFERENT VEGETABLES**

K. Kacz K. – A.J. Kovács – Zs. Stépán Zs. – M. Neményi  
University of West Hungary, Faculty of Agricultural and Food Sciences, Institute for Biosystems Engineering, Mosonmagyaróvár

Drying characteristics of different vegetables have been examined at the Institute for Biosystems Engineering for four years. Thin layer drying experiments were conducted based on a National R&D Program. Our aim was to model the drying

inside belt driers in practice. Drying curves were determined in order to describe the heat and mass transport processes. The moisture gradients as driving force can be calculated from these equations. Our aim is to use water potential gradients instead of moisture gradients in modeling of mass transfer. In order to do this, sorption measurements were carried out in carrots. From the sorption curves water potential and pF values can be determined. Based on these examinations the heat and mass transport modeling was established.

### **DYNAMIC AND STATIC METHODS OF KERNEL HARDNESS MEASUREMENT**

A. Véha – E. Gyimes – B. Szabó P.  
Faculty of Food Engineering, University of Szeged

In the last few decades the interest in the commercial classification of wheat varieties has increased significantly making the need for dividing kernels into hard and soft ones based on their kernel texture even greater. In our investigation we used two dynamic methods (Perten SKCS 4100 measuring device and Perten 3303 disk-type mill) and a quasi static method (LLOYD 1000 R testing machine) to measure kernel hardness. Our objective is to compare and critically analyse these three methods.

Our results suggest that all three methods are suitable for determining wheat kernel hardness. The static measuring method is a far more precise way of determining the kernel hardness of the same varieties harvested in different years. Besides, the results we received are far more informative. Dynamic methods, on the other hand, are quicker and show more resemblance to the milling processes.

### **OPTIMAL FREQUENCIES OF INERTIA TYPE FRUIT TREE SHAKERS**

*(Sponsored by the Hungarian Scientific Research Fund)*  
Láng Z.

Technical Department, Corvinus University, Budapest

Optimal shaking frequency can be defined in many ways. In this paper optimal shaking frequency means shaking the tree at one of its natural frequencies, whereby the efficiency of the power input is the highest.

### **ENERGY ASPECTS OF WIND MEASUREMENTS IN HUNGARY**

N. Schrempf – G. Tóth – L. Tóth  
Szent István University, Gödöllő

The Hungarian wind atlas has not been ready yet, so we can choose a place to install just randomize or lean on the meteorological measuring, and after the necessary local wind measurements can we decide where rewarding the installation. The main objectives are:

- to analyse the data of long-term measuring at several places, to show our experiences, and find out the trends and the criterions
- to analyse the Hungarian wind characteristic (wind speed, wind direction, the Hellmann's coefficient, the expectable energy production etc.), after the interpretation to show the Hungarian specialities, to give recommendation to selection the installation place, the mode of the measuring, and the recommended tasks during the analysis
- to define the correct parameters for the investors and the manufacturers, which help them to choose the best solution and best efficient wind generator
- by means of the analysing the Hellmann's coefficient to give an input data's to the Hungarian wind atlas, and a control data's locally or all around the country

## IMPROVED THEORY OF HYDRAULICAL ATOMIZATION

István Sztachó-Pekáry  
College of Kecskemét, Kecskemét

In this study our previous two – against surface tension and against viscous shear force based – theories were improved. In the new, complex equation we consider force balance for a droplet separating radially from a liquid sheet. We consider that a small mass  $\Delta m$  with a radial velocity is separating into a droplet. The analysis of the equations revealed that the calculated effect of drag force for  $\Delta r=0d-25d$  on drop velocities was negligible for a water spray in still air; furthermore the assumptions that a droplet separates only laterally did not prove to be right; and erroneous estimation of dynamical pressure  $p$ ; and inappropriate incorporation of spray angle  $\alpha$  were also revealed.

## NEW METHODS FOR THE EVALUATION OF HYDRO MOTORS

S. Török – Z. Bárfai  
Szent István University, Gödöllő

The scope of hydraulics is growing permanently year by year. Nowadays it is inconceivable that a modern agricultural machine has no hydraulic system.

During the operation all the structural elements of a hydro motor abrades. Because of this the leakage loss increases which has an effect on the operational parameters. The result is: the volume flow, the pressure, the effective power and the power uptake, and the sum-efficiency. Several kind of diagnostic tests have to be taken in order to make decision of how long is worth to continue the operation [1]. Tests can be carried out by special hydraulic testers, or by a hydrostatic measuring bench.

Testers are used for registering the following physical parameters: volume flow, pressure, temperature, and seldom r.p.m.

The hydrostatic test benches are usually used where manufacturing, fixing, maintenance, and testing of hydraulic elements is in progress. Hydrostatic test benches are able to measure several kinds of physical parameters – as volume flow, pressure, temperature, torque, r.p.m.-needed for recording curves.

## RELATIONSHIP BETWEEN FARM SIZE AND MECHANIZATION

J. Hajdú – L. Gockler  
Hungarian Institute of Agricultural Engineering, Gödöllő

The Hungarian farm and property structure has been changing continually recently. The rapid devolution is followed by a slow concentration. The size of applicable machines, the utilization of machines and the costs of machine work basically depend on the size of property to be tended and the size of cultivated fields at the same time.

Practical and model calculations show that power- and working machine demand as well as engine power demand can be reduced by 50-66 % specifically between 10 and 1000 ha. Increasing the engine power and capacity of power machines results in a sharp reduction of the cost of machine work at performance categories between 40 and 100 KW. The reduction is moderated afterwards but is still significant. Machine demand, performance provision, the volume and cost of machine work can substantially be reduced – by 75-66 % - on 1 to 10 ha fields, on a field size exceeding 20 hectares the decrease is not so significant.

**Key words:** agricultural mechanisation, property size, machine utilisation, machine investment and utilisation cost, power machine demand

## ECONOMIC ANALYSIS OF MECHANIZATION TECHNOLOGY OF FIELD VEGETABLE PRODUCTION

L. Magó – F. Jakovác  
Hungarian Institute of Agricultural Engineering, Gödöllő

In this paper the economic investigation of field vegetable production is introduced by using the production technology of the most important vegetables, onion and tomato as examples.

*Onion* is a very important vegetable that plays a very significant role in human nutrition. Practically onion is produced in every part of Hungary on large, as well as on medium and small farms, on 5-8 thousand hectares altogether.

Seed-grown vegetable onion is gradually gaining ground on the traditional onion set production method. In our present days there are good seed-grown species available for farmers. These species can provide good quality products and can be stored well.

Tomato is one of the most popular vegetables in the world, produced on very large lands. Canning tomato is a very significant vegetable in Hungary as well, traditionally produced on a very large land – 3700-4000 hectares – by transplanting or direct seeding methods.

This paper focuses on introducing the mechanized production technology of seed-grown onion and direct-seeded canning tomato.

The paper also aims to promote the popularization of the modern technology of field vegetable production by reviewing production technology and providing useful pieces of information on the operational and economic figures of the machines necessary for production.

**Key words:** field vegetable production, machine technology, machine investment and utilisation cost

## EFFECT OF NUTRIENT SUPPLY ON THE VALUE OF FIELDS IN HUNGARY

Z. Peszeki – Zs. Szentpétery – I. Kovács  
Szent István University, Gödöllő

Analyzing Hungary's capabilities we can agree, that our arable stock, which is available in limited amount and cannot be enlarged much more, plays more and more important role of our resources.

From the whole area of the country (9 303 400 hectare) the agricultural land was 5 million 865 thousand hectare in the 31st May 2003. The size of the arable lands -which contains the area of the forests, reeds, fish ponds too apart from the agricultural lands- is 7 million 734 thousand hectare. The size of the ploughland, which determines the agricultural production, is almost 4516 thousand hectare, but the forests' (1775 thousand hectare) and green's (1062 thousand hectare) ratio is considerable too.

There are two things which change basically in the Hungarian land market by reason of the EU membership. The first well-known change is the entering of land based support. The second indirect change will be the interest of the capital of EU, because the capital of EU wants to achieve the domestic market contribution in the connected country's market too, and looks for the promising opportunities.

The EU's land cultivating enterprises and private persons (not the owners) owing agricultural land based support is an income complement support, which encourages the economic activities. The amount of it is 70.000 HUF/ha/year now in the EU. From this we get 25% (17.500 HUF) in 2004, and it increases annually. The Government may expand this part additionally with 30% (21.000 HUF). In 2004 the initial amount of the support was 38.500 HUF/ha/year. To compare with 2003: in that year the land based support was 7.000 HUF/ha/year in Hungary, and nowadays 30-40 thousand HUF means a good profit in a year per hectare. So the income can double.

## THE ROLE OF EXTENSION IN THE TECHNICAL IMPROVEMENT OF AGRICULTURAL ENTERPRISES

K. Tóth – J. Bárczi – Cs. Fogarassy  
Szent István University, Gödöllő

International statistical figures prove that in the last decade, those countries have been the winners for the global economic competitiveness, where higher level of activity in extension, agronomic research and teaching has been running, and on the contrary, there is a developed institutional network (P. Horn 2002). In these countries, extension is the one that provides information on farmers to produce efficiently (J. Kozári 2003). In Hungary, advisory system relying upon the basis of entrepreneurs supported by the state ought to be reformed. In its present structure, it does not improve agricultural entrepreneurs' informational level and knowledge efficiently. Beyond improving the level of extension, advisory system ought to take upon itself the role of development and innovation (Dimény I.-Hajós L. –Szűcs I. 2003). In order to improve agricultural entrepreneurs' economic competitiveness, they have to put more and more emphasis on improving technical innovation. Adopting technologies within agricultural enterprises is such a complex area that farmers tend to put experts and advisers in charge of these kind of services. In the course of research, we have analysed the demands of agricultural enterprises raised on extension services in connection with technical support.

## EXPERIMENTAL DEFINITION OF THE PRIMARY FORCE OF STUMP

E. Horváth-Szováti – I. Czupy  
University of West Hungary, Sopron

Removing tree trunks in Hungary has been going on according to the principle of stump extraction, which means stumps are removed by grabbing technology. Experiments have been carried out to reduce primary input. In the Great Hungarian Lowland, where there are really enormous areas where forest machinery is required to implement that kind of particular operation, stump extraction is done by special, hydraulic driven caterpillars equipped with sophisticated grabbing devices. During operation of the equipment, different measurements are carried out so as to verify the suitable power supply. The experiments are designed to carry out the measurements with different soils and different tree species. Meanwhile the time requirement is also taken into serious consideration. In the course of the evaluation procedure of our findings, a widely applicable method of parameter estimation - supported by regression-estimation - is shown.

Keywords to support the mathematical background of the procedure: linearization into Taylor-line, principle of the smallest squares, matrix-equation, and iteration.

## MEASUREMENT OF FOREST ROAD BY GPS

J. Péterfalvi – G. Markó  
University of West Hungary, Sopron

The network of forest roads defines basically the approach of opened up area. After planning and construction this network needs of maintenance. The established opening up network needs continuously rethought dynamic developing because of the changing of influencing factors. This tasks can be solved with a GIS with exact digital map and proper descriptive data basis. The development and maintenance of forest road network demands exact tracing of roads on the digital map, to have reliable and exact connected data. This claim can be contented with the widely applied GPS technology. This paper introduces the experiments and results in this fields at the Institute of Geomatics and Civil Engineering at the University of West-Hungary.

## EFFECT OF MOISTURE CONTENT CHANGE ON COLOUR CHARACTERISTICS OF PAPRIKA POWDER

Zs. H.Horváth – A. Véha  
Faculty of Food Engineering, University of Szeged

The use of natural food colours is preferred to that of artificial dyestuffs for by modern alimentary purposes. Paprika is a spice plant grown and consumed in considerable quantities worldwide, and also used as a natural food colour. Hungarian paprika powder is still regarded as a "Hungaricum" today. Paprika is cultivated in areas of the world such as Spain, South Africa and South America, where the weather is favourable for the growth of this plant and for the development of its red colouring agents. The large number of hours of sunshine allows the paprika to ripen on its stock, so that the basic material reaching the processing mills has a high dyestuff content. Hungarian paprika has a unique aroma and a specific smell, but the production of powder with a good red colour is a considerable problem.

## MEASUREMENT ASSEMBLY FOR ENERGETIC ANALYSIS OF COMMINUTERS

P. Korzenszky – E. Judak  
Szent István University, Gödöllő

Taking the results gained up to now, in the course of the mechanical investigations on comminuting machines (first of all impact mills) as a basis, a new measurement system was constructed. The system is suitable for investigating the states in continuous regime ranges as well between the earlier set discrete parameters as against that in the former stepped measurements. Besides the infinitely variable rotary-speed adjustment, the measurement assembly is usable and indispensable to the work on understanding better the comminution process and grounding its comminution-kinetic description. On the basis of the analysis of the experiments carried out and the conclusions drawn, a mechanically and energetically well-founded control and regulation circuit, utilizable in the practice as well, can be elaborated. The system with its present form, through using the independent parameters revealed during the investigation, is already capable of operating as a feedback regulation circuit (it may be considered a pilot-scale control device as well).

## APPLICATION OF ULTRASOUND TECHNIQUES IN WASHING PLASTIC BOXES AND CRATES

Gy. Mészáros<sup>1</sup> – Z. Csizmazia<sup>2</sup>  
<sup>1</sup>College of Food Engineering of the University of Szeged.  
<sup>2</sup>Centre of Agricultural Science University of Debrecen

The food industry uses a large amount of plastic cases, boxes and containers for transportation within and outside of the company. These contain strong bounded dried, bloody and fatty contaminations. Their removing is difficult especially in case of complicated surfaces. The traditional washing machines equipped with high pressure nozzles are not able to remove the contaminations from places situated in shaded areas (ribs, holes, and corners). It can not be accepted in case of tools having direct contact with foods. Therefore we investigated the introduction of ultrasonic procedure for cleaning of objects having

## STUDY ON TEMPERATURE AND MOISTURE DISTRIBUTION INSIDE THE BATCH OF CONVECTIVE CORNCOB DRYER

J. Beke – G. Bihercz – Z. Kurják  
Szent István University, Gödöllő

Convective drying is one of the most favored drying methods of drying industry because of its simple build-up and relative low investment cost. However, the high improvement of the

convective drying technology (enrichment of quality and quantity of drying product) may cause difficulties of drying process, especially in the seed production. We aimed to measure the temperature and moisture distribution inside a batch type modern convective corn cob dryer. A unique measurement system has been prepared for this purpose and a huge level data acquisition has got a special chance to draw down some meaningful conclusions.

### HOMOGENIOUS MICROWAVE FIELD CREATION

E. Lakatos<sup>1</sup> – A. J. Kovács<sup>1</sup> – M. Neményi<sup>2</sup>

<sup>1</sup>University of West Hungary, Mosonmagyaróvár

<sup>2</sup>Research Group Process Engineering of Agricultural Products of the Hungarian Academy of Sciences, Mosonmagyaróvár

Microwave treatments are very common in various food processes such as drying, pasteurization, cooking and enzyme activation [1]. Almost all the time a problem occurs during microwave treatments, namely that the energy (and consequent temperature) distribution inside the radiated materials is significantly uneven [2]. The results of treatments are hardly reliable by this non-homogeneous temperature distribution. At the Institute of Biosystems Engineering preliminary studies were carried out using an own-built experimental microwave oven in connection to temperature distribution of treated liquids [3]. In this apparatus there was not possible to regulate the magnetic field for various reasons. Therefore, a domestic

microwave oven with fiber optic thermometer system was installed for microwave researches of liquid foodstuffs.

### EFFECT OF ADDITIVES ON TRANSMISSIVITY AND TEARING STRENGTH OF THE GREENHOUSE COVERING PLASTIC FILMS

V. Madár – M. Szabó – E. Judák  
Szent István University, Gödöllő

The double plastic film covered block greenhouses are the new products of the last 10 years and their speedy development is assured by the cheap plastic films. The main disadvantage is the lower light transparency than glass and because of the double using for the better insulation the light transparency is much more reduced. In most of the cases the type of the inner and outer layer is the same which is not the best solution for the spectral transmissivity from the plants point of view.

The basic material of agricultural covering plastic films for greenhouses is Polyethylene (PE). The basic additive is the UV-absorption additive for ensuring the UV stability and other additives for the stability which brake the degradation due to oxygen, improve a resistance of the plastic film against chemicals. It is important for the span of life of the plastic.

The aim of the research is to find out such an adequate coupling of film layer which provide an advantageous spectrum from energetic, physiological and forcing point of view and in such a way that the selected couple of film layer can fulfill the stress requirements coming from the different forming of greenhouse structure.

## PART II.

### SELECTED SCIENTIFIC PAPERS

# COMPLEX COMPARISON OF TRACTOR TRANSMISSION SYSTEMS BETWEEN CONTINUOUSLY VARIABLE TRANSMISSION AND POWERSHIFT TRANSMISSION

Zs. Kassai – M. Szenté

Non-profit Co. of the MGI for Quality Testing, Gödöllő

## Introduction

The main exercises are to ensure maximum power (i.e. cultivated area, transporting power) and agro technical and optimal working speed at tractor-implement aggregate operation.

Significant points are minimizing of costs and specific fuel consumption. This needs to ensure harmonized connection between the tractor engine and characteristics of transmission system at working points on field.

The transmitting-power response is the main operational problem at transmission systems.

Most important exercise is reliability assessment of tractor transmission systems: such all requirements for farmers a fail-safe construction which satisfies operating demand on the field. Application of gear ratio of continuously variable transmission and their centralized control together gives several advantages for the agriculture. For that reason we measured more tractor transmission systems for operating advantage in last years.

The aims of our research works were the follows:

- Determine adequacy of tractor transmission systems for demands of the agricultural labour.
- Evaluation and analyze of exercises to transmission systems.
- Determine field application for tractor transmission systems.
- Development of test method on the base tractor-implement connection and continuous test of their transmission system.
- Evaluation of the test results.

## Materials and methods

Our complex transmission test system (Fig. 1) was phased two parts, first part was the simulation and second one was the test on basic measurement. The traditional test was phased further two tests: laboratory test and test on field. In the laboratory we determined the engine characteristics. For the test on field we composed a multilevel serial test, where we executed a transporting tests series as tractor-implement test.

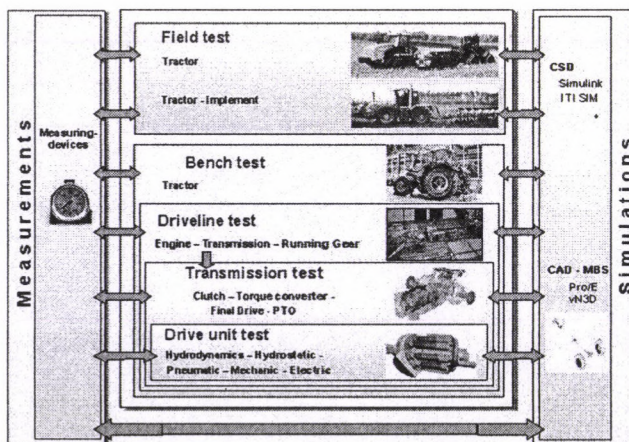

Fig. 1 Test possible methods of tractor transmissions

The investigation of driving systems of tractors is a complex, time-consuming and costly project and can only be completed by field and bench tests. Using the result of the new development of information technology, the simulation method can be extended to all levels of the driving system examinations, as shown in the figure, including the tractor-implement matching.

This new method can be more economic and cost saving, and gives a chance to optimize the testing system.

The bench test was prepared at the laboratory of Hungarian Institute of Agricultural Engineering, where the engine characteristics were determined.

The load of the engine was ensured by a SCHENK W-400 bench, a dynamo meter, and was put on the PTO, and the fuel consumption was measured by a PLU 116H indicator.

A field test program (Fig. 2), which is the second stage of the complete comparison process has been developed. The two basic steps of our program are the tractor drawbar test (following the MGI 39-1-321 and OECD CODE I standards) and tractor-implement test. The tractor-implement matching test was divided in several parts: transport, high power operation and PTO (Power Take-Off) operation tests.

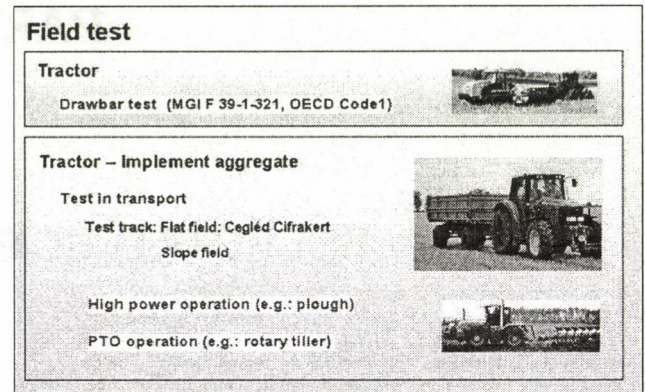

Fig. 2 Test methods of field test

We divided traditional tests into two parts: test in laboratory and test on field. For test on field we composed a multilevel serial test: the basic levels are including drawbar power test and test of tractor-implements. The tractor-implement test was phased two parts: transport and high drawbar capacity test.

We measured the tractors in same adjustment, namely: engine power, tires sizes and pressure, axle load with extra weight, but tractor transmission systems were different (Continuously Variable Transmission system opposite to Powershift Transmission system).

For the transport tests series we executed a special measuring track (flat surface). The test was done by unloaded and loaded tractor with two axles trailer (load capacity ~10 tons). The tractor with Continuously Variable Transmission was tested in different positions of the potentiometer of load controller.

During all test we measured and registered the followings:

- time [sec],
- engine speed [min-1],
- travel speed [kmh-1],
- fuel consumption [dm3h-1],
- front and rear wheel speed [min-1] and
- trigger [V] signal, to separate the test sections and the drag strategies

The measuring transmitters gave signs in SPIDER mobile data measuring and collecting system.

More tractor types executed test results held up the efficiency of measuring method and simulation model.

The transport test was prepared on a special flat field test track located in Cegléd Cifrakert. The test track includes field covered wheat stubble, ground road and concrete road sections.

For the test track specifications see the Fig. 3.

The sections were divided into further sub-sections for example: constant speed, acceleration, etc., according to the agricultural application requirements.

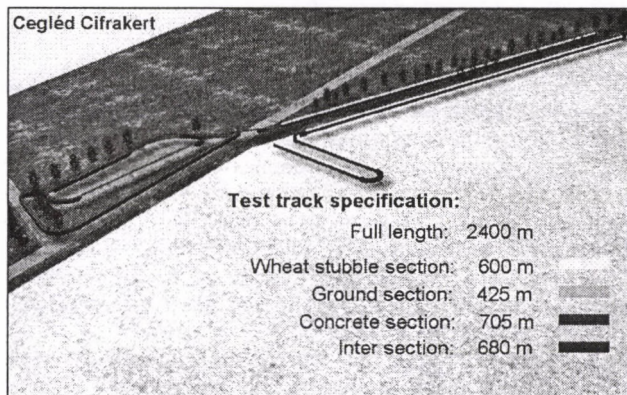

Fig. 3 The test track of transport test

The investigated tractors had same engine characteristics, tire dimensions and pressure, and their axle loads were also the same.

**Results**

We developed a Simulation-program (together with researchers of the Technical University Department of Mechanics in Budapest).

The Simulation-program is suitable to calculate of measuring data and other parameters (i.e. gear ratio, consumed fuel [dm<sup>3</sup>], distance [m]). The Simulation-program is able to figure in real time the change of mentioned characteristics.

On the Fig. 4 we can see the chart of the measured features for the whole spectrum in the case of CVT with 0 position of full load potentiometer.

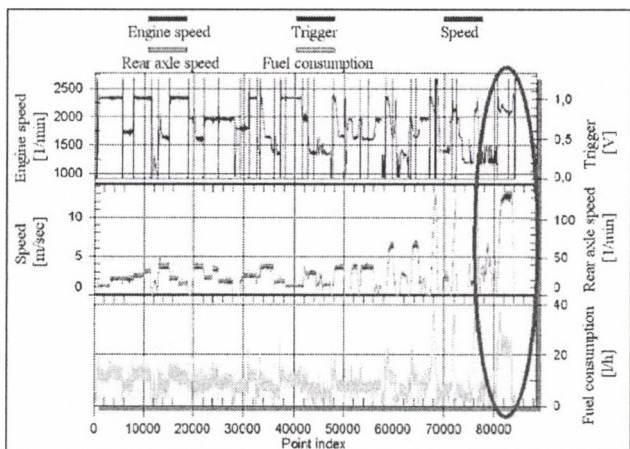

Fig. 4 The chart of the measured features for the whole spectrum

We would like to present the results showing the acceleration section on concrete marked with the ellipse.

In this part of test the differences are most perceptible between the two tested transmission system at acceleration from low unloaded engine speed to highest travel speed and keeping maximum travel speed.

Table 1 The results of acceleration during transport

Tractor type	Unloaded tractor			Loaded tractor (with trailer)		
	Travel speed at the end of acceleration process (km/h)	Elapsed time for acceleration (s)	Fuel consumption during acceleration (dm <sup>3</sup> )	Travel speed at the end of acceleration process (km/h)	Elapsed time for acceleration (s)	Fuel consumption during acceleration (dm <sup>3</sup> )
John Deere 7820 (Powershift)	42,1	17,0	0,130	33,5	22,4	0,168
John Deere 7920 (CVT in manual operation mode)	42,1	13,2	0,095	33,6	7,6	0,045
John Deere 7920 (CVT in "3" automatic operation mode)	42,1	10,4	0,088	33,5	9,2	0,047

To analyze and present the data, simulation software was developed. The user interface of the software can be seen on the Fig. 5.

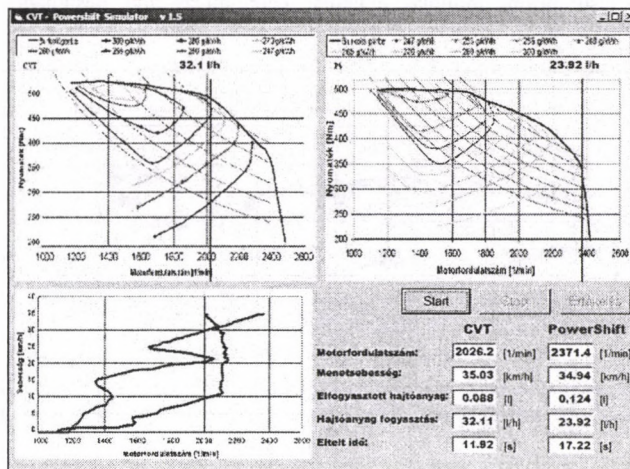

Fig. 5 The user interface of CVT - Powershift Simulator

The two top diagrams show the engine characteristics. On the bottom left there is a speed in function of rpm diagram, on the right side the actual values of the measured and calculated data can be seen.

From the measured data we determined the followings:

- Measuring time on the testing points,
- Fuel consumption,
- Number of handling of lever control (i.e. shift lever),
- Wheel slip,
- Time of acceleration, constant speed, braking, etc.,
- Fuel consumption attached to acceleration.

The effect of the position of potentiometer of load governor to:

- Engine speed,
- Tractor speed,
- Drawbar pull,
- Drawbar power.
- Fuel consumption.

We compared the test results given for tested transmissions. We can see the differences of acceleration times on the Table 1. The less time is necessary in the case of CVT transmission in automatic operation mode. In the case of loaded tractor the less time is with CVT transmission also but in normal operation mode.

We figured the operation points of the engine in general characteristics curves (Fig. 6). The operation points are at drawbar pull of 30 kN, and six different speeds. The specific fuel consumption values were lowest by 5-10 % with Continuously Variable Transmission system than Powershift Transmission in all position.

**Conclusions**

The result of quick and accurate computer programming is perfect corresponding between engine and Continuously

Variable Transmission system. It is absolute conform together the engine speed and gear ratio to situation, travel speed and load. In this way achievable the followings: optimal fuel consumption, minimal exhaust, economical and designable operation.

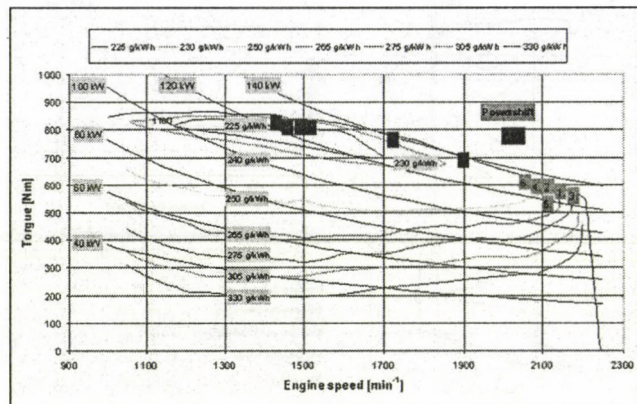

Fig. 6 The operation points of the engine at 30 kN drawbar pull

## References

- [1] Szente M. – Lampel H.: Traktor hajtóművek értékelése hatásfokuk, kezelésük és sebességfokozat átfedésük alapján. TÉT A-2/02 zárójelentés, Gödöllő, 2005, p2-14 p.
- [2] Kassai, Zs. – Szente, M.: Complex comparison of tractor transmission systems between Continuously Variable Transmission and Powershift Transmission. VDI-MEG Tagung Landtechnik 2005. VDI-Berichte Nr. 1895, 2005, pp. 475-481.
- [3] Farkas, Zs. – Kerenyi, Gy.: Comparison test of powershift and continuously variable transmissions. Hungarian Agricultural Engineering. No. 17/2004. pp. 15-17.
- [4] Bisaglia, C. – Cutini, M. – Gruppo, G.: Potential and testing of continuously variable transmission. Proceedings of XXX CIOSTA, 22-24 September, 2003. Grugliasco, Italy, pp. 255-262.
- [5] Farkas, Zs. – Jori, J.I. – Kerenyi, Gy.: The application and modelling possibilities of CVT in tractor. 5<sup>th</sup> International Multidisciplinary Conference, Baia Mare. 23-24 May 2003. Part II. pp. 145-150.
- [6] Paoluzzi, R. – Rigamonti, G. – Zarotti, L.G.: Simulation studies of vehicle-transmission interactions. Journal of Terramechanics, 1996. Vol. 33., No. 3., pp. 143-153.

## NEW METHODS OF FRUIT TREE SPRAYING

Gy. Dimitrievits<sup>1</sup> – Z. Gulyás<sup>1</sup> – L. Kovács<sup>1</sup> –  
P. Sallai<sup>2</sup>

<sup>1</sup> Hungarian Institute of Agricultural Engineering, Gödöllő

<sup>2</sup> Pomological Research and Consulting Non-Profit  
Company, Újfehértó

### Introduction

In order to have a successful pomiculture, the effective plant protection is necessary. The success of the protections greatly depends on besides the applied chemicals, doses and other factors, the development of the spraying machines and their operational conditions. Previous surveys have proven that the application of an inappropriate spraying machine and due to incorrect settings nearly 30-40 % of the sprayed chemicals never reach the target surface, but they fall on the ground or get drifted, and charge the environment unnecessarily. In the cases of some of the treatments the losses can even reach 90 %. It can be often experienced that due to the application of a technology inappropriate for the plantation's abilities, the spread of the chemical deposited on the foliage is also not balanced enough, thus there are over-sprayed and under-sprayed surfaces. Its main reason is that the setting of the spraying machines out of date to the location of the foliage is limited and the spraying is performed without taking the location of the foliage under consideration. As a result, a significant part of the spray drops is blown above and under the plants and becomes useless. Therefore most of the spray solution fails to reach the target surface and gets wasted. Besides the economical damages it results, there is a remarkable environmental pollution due to the drifting, evaporating spray that deposits on the ground. It is even more disadvantageous for the new nursery plantations and in the cases of the cleansing sprayings at the end of the winter, when the losses can even reach 90 %.

The currently used spraying processes do not always consider the fact that due to the age of the plantation, its phenological condition and block or tree deficiency, the foliage of the plants is not continuous, and that in the foliage between the sprouts and branches there are no leaves. As a result a significant part of the spray solution fails to reach the target surface, thus gets wasted. In order to operate the machines professionally according to the plantation's abilities, the accurate knowledge is often missing and no modern technological recommendations are available.

### Material and method

The deposit of the spray solution on the foliage was determined by applying open-ground coverage inspections. In the tree-top, we placed samples made of water sensitive paper on both sides

of the leaves on 3 height and 3 depth levels depending on the location of the foliage. Using these sprayed samples, we could determine the coverage with a computer program. Also we checked the quantity of the liquid deposited on the ground by applying this coverage measuring. In the treated rows, in the rows next to them and in between the rows, based on the samples placed on the ground, we could determine the quantity of the spray falling on the ground.

When determining the savings of the spray solution, with the spraying machines equipped with plant detector devices, we sprayed a specific quantity of liquid with the same settings with turned on and turned off plant detector and we determined the size of the treated area. By comparing the results of the specific spraying quantity values, we calculated the percentages of the savings. The characteristics of the treated plantations are included in table 1.

The most important technical features of the spraying machines involved in the examination have been checked by laboratory inspections. The results are included in table 2.

### Results

#### *Work quality inspection of the spraying machines with a standard system*

We examined the work quality of the KERTITOX BORA 2000, KERTITOX BORA 1000 and KERTITOX 600 spraying machines, which have the same manufacture but equipped with an axial ventilator with different capacities and different spraying device, on an apple plantation with a 5 m row-space and a 3 m stock space. The measured values of coverage are included in table 3.

According to the results, the standard KERTITOX BORA 2000 spraying machine with the highest ventilator capacity ensured the largest and most balanced coverage regarding the whole foliage.

The KERTITOX BORA 1000 spraying machine with a lower capacity and parabolic spraying device produced a quite balanced coverage in the areas near the machine. However, on the further surfaces of the foliage the coverage was smaller. Its reason is the adverse narrow outlet, which causes turbulence and slows down the outgoing air stream. The KERTITOX 600 machine's range is even smaller, where the low air capacity does not make it possible to have an adequate coverage on the foliage further away, and the balanced treatment of the foliage. However, with a smaller speed – considering the treatment of the trees on both sides – this machine can be appropriate to treat plantations with a narrower row space.

Table 1 Characteristics of the treated plantations

Fruit	The type of fruit	Row space	Stock space	Height of the trees	Distance of the loader
apple	Jonathan	500	200	300	0,5
apple	Jonathan	500	200	400	2,0
apple	Golden D.	700	350	300	1,0
apple	Golden D.	500	200	400	2,0
apple	Sampion	340	200	300	0,5
apple	Starking	600	300	350	1,0
apple	Starking	500	200	400	2,0
apple	Florina	500	200	400	2,0
apple	Idared	600	300	300	1,0-2,0
sour cherry	Debreceni seedful	800	500	600	2,0

Table 2 Main technical features of the spraying machines

Type of the machine	The pump's delivery capacity (dm <sup>3</sup> /min)	Maximum operating pressure (bar)	Ventilation system	Air out-put/in-put of the ventilator (m <sup>3</sup> /h)	Shape of the spraying device
Kertitox BORA 2000	148	50	axial	28.700-53.900	round
Kertitox BORA 1000	109	50	axial	22.000-42.500	parabola
Kertitox 600	105	20	axial	18.000-20.100	vertical

**Table 3 Coverage on an apple plantation**

Height level	Level inside the foliage	Average coverage (%)			Coverage ratio on both sides of the leaves		
		Kertitox BORA 2000 standard	Kertitox BORA 1000	Kertitox 600	Kertitox BORA 2000 standard	Kertitox BORA 1000	Kertitox 600
lower	I.	44	36	32	1,4	1,8	1,8
	II.	28	18	15	1,5	1,7	1,8
	III.	10	7	4	1,6	1,8	1,9
central	I.	38	35	34	1,1	1,4	1,6
	II.	26	18	12	1,2	1,7	2,1
	III.	10	6	5	1,7	2,2	2,4
upper	I.	28	21	14	1,3	1,6	1,9
	II	13	8	5	1,8	2,1	2,4
	III.	6	4	1	1,9	2,6	2,8

The coverage ratio on both sides of the leaves was the smallest in the case of the standard KERTITOX BORA 2000 machine, where the achieved values of 1,1-1,9 – compared to other examined machines – can be considered as a rather good result. In the case of the linear KERTITOX BORA 1000 machine the range between 1,4 and 2,6 can also be considered good enough. The 1,6-2,8 result of the low capacity KERTITOX 600 can also be acceptable considering the fact that the spraying in the next row significantly decreases the ratio of the coverage on both sides of the leaves.

In order to be able to comprehensively adjudge the quality of the works performed by the machines, we examined the losses of each machines showing on the ground.

The size of the coverage on the ground was the following:

- KERTITOX BORA 2000 standard 1-12 %,
- KERTITOX BORA 1000 2-20 %,
- KERTITOX 600 5-43 %.

**Work quality inspection of the spraying machines equipped with a plant detector**

In order to be able to determine the work quality features of the spraying machines equipped with a plant detector, we measured the coverage on nursery plantations with and without a plant detector.

With the KERTITOX BORA 2000 spraying machine, which has an infra red sensor, during the measuring of an apple plantation planted on 4,5 x 2,5m, the operational pressure was 16 bars, the work speed was 6 km/h, the specific spray solution usage with a turned off sensor was 600 dm<sup>3</sup>/ha, with a turned on sensor it was – due to the savings – 365 dm<sup>3</sup>/ha. The results are included in table 4.

According to the results it can be stated that between the qualities of the spraying performed with two different technologies there was no demonstrable difference. In the different plant zones the limit values of the coverage, as well as its average were nearly the same. There was no significant difference in the quantity of the deposited spray on either side of the leaves. During the analysis of the data it also became clear that on the edge of the foliage, where the plant detector device stopped the spraying, the coverage was also almost the same in the cases of both technologies. The device turned off the spraying with the accuracy of 0-4 cm, and at the edge of the tree-tops, the foliage, which has a smaller surface, received enough spraying.

Thus the application of the plant detector device did not change the quality of the spraying; the size and spread of the coverage remained almost the same.

**Inspection of the spray solution saving in the case of plant detector spraying machines**

In order to be able to determine the savings of the spray solution achieved by the application of the *infra red plant detector device*, we performed operational experiments on apple plantations. We sprayed in the same areas and with the same settings with a turned on and turned off plant detector device. In every case we determined the quantity of the used spray solution and the range of the savings due to the application of the plant detector device. The results we got on the different plantations are included in table 5:

In order to be able to determine the savings of the spray solution achieved by the application of the *ultra sound plant detector device*, we performed measuring on new apple, plum, cherry and sour-cherry plantations. During the examinations we sprayed the plantations with the same settings and with turned

**Table 4 Coverage in apple orchards**

level of height	level of depth	side of leaf	coverage (%)			
			without plant-sensors		with plant-sensors	
			end values	average	end values	average
lower	I.	adaxial surface	42-20	29	44-22	31
		abaxial surface	28-13	17	27-13	15
	II.	adaxial surface	33-17	24	30-15	23
		abaxial surface	22-11	14	25-14	15
	III.	adaxial surface	30-13	21	26-16	20
		abaxial surface	17-6	12	18-9	12
central	I.	adaxial surface	45-19	30	51-21	28
		abaxial surface	28-12	19	31-10	18
	II.	adaxial surface	36-17	23	32-14	19
		abaxial surface	20-7	10	17-6	9
	III.	adaxial surface	26-12	17	26-13	18
		abaxial surface	15-6	9	15-7	10
upper	I.	adaxial surface	37-17	25	40-19	26
		abaxial surface	27-11	17	23-10	15
	II	adaxial surface	30-12	18	32-14	20
		abaxial surface	21-8	11	16-7	10
	III.	adaxial surface	23-14	17	25-12	17
		abaxial surface	12-5	7	13-5	8

**Table 5** The results of the spray solution saving examination with an infra red detector system

Plantation	Working mode	Specific spray solution usage (dm <sup>3</sup> /ha)	Spray solution saving (%)
apple	With turned off plant detector	689	28,1
	With turned on plant detector	508	
apple	With turned off plant detector	626	55,3
	With turned on plant detector	196	

**Table 6** Spray solution saving in fruit plantations

Plantation	Working mode	Specific spray solution usage (dm <sup>3</sup> /ha)	Spray solution saving (%)
apple	With turned off plant detector	857	66,3
	With turned on plant detector	248	
plum	With turned off plant detector	856	52,1
	With turned on plant detector	420	
cherry	With turned off plant detector	849	68,4
	With turned on plant detector	205	
sour cherry	With turned off plant detector	908	49,8
	With turned on plant detector	422	

on and turned off plant detector device. In every case we determined the quantity of the used spray solution and the range of the savings due to the application of the plant detector device. The results are included in table 6.

The data show that by using the plant detector device the spray solution saving altered between 49,8 % and 68,4 %. The plantation spraying machines that are used most often in practice have 6-8 spray-cones on each side. The height and location of the plantations' foliage do not always make it necessary to operate all spray-cones. Among the spray-cones located in the round shape outlet of the axial ventilator, the upper 1-3 spray-cones are usually not used, because the spray drops streaming out of them fly over the foliage vineyards and modern fruit plantations, and mainly get wasted. It is similar in the case of the lower 1-2 spray-cones, where most of the spray solution deposits on the ground directly. Due to the fact that the direction of the air-stream of the spray-cones and ventilator can only be set in a small range, these spray-cones usually have to be closed. The space between the operating spray-cones in such case does not make it necessary to use as many sensors as many spray-cones are open. On new plantations the foliage of the trees is not continuous; therefore the connections can be ensured with one sensor on each side.

### Summary

During the examinations, besides the spraying machines equipped with axial ventilators, the standard KERTITOX BORA 2000 and the KERTITOX BORA 1000 for intensive plantations, we studied the KERTITOX 600 spraying machine, as well, which is equipped with a linear spraying structure and a axial ventilator. We also examined the KERTITOX BORA 2000 plant detector spraying machine with infra red and ultra sound systems. The range of the coverage on both sides of the leaves was the lowest in the case of the standard KERTITOX BORA 2000, where the achieved values of 1,1-1,9, compared to

other examined machines, are quite good results. In the case of the linear KERTITOX BORA 1000 machine the range 1,4-2,6 can also be considered good. The low air capacity KKERTITOX 600 machine's result 1,6-2,8 can also be acceptable considering the fact that the spraying in the next row significantly decreases the ratio of coverage on both sides of the leaves. By applying the infra red plant detector device we had a spray solution saving of 28,1-55,3 %. By applying the ultra sound plant detector device, the spray solution saving altered between 49,8 and 68,4 %.

### References

- [1] Fenyvesi L.-Gockler L.-Hajdú J. (2003): A mezőgazdaság műszaki fejlesztésének lehetséges megoldása. *Gazdálkodás* 5. szám, p 1-15.
- [2] Dimitrievits György, Gulyás Zoltán, Kovács László és Magó László (2004): Növényérzékelő permetező berendezés gyümölcsültetvényben. XXVIII. Kutatási és Fejlesztési Tanácskozás az agrárgazdaság gépesítéséről. Szent István Egyetem, Gödöllő. *Poszter-Kiadvány (előadások és konzultációs témák tartalmi összefoglalói* ISBN: 963 611 406 4) – Konzultációs témák, p. 43.
- [3] László Alfréd, Pályi Béla, Lönhárd Miklós és László Alfrédné (2004): Környezetkímélő permetlé kijuttatás, elsodródás. XXVIII. Kutatási és Fejlesztési Tanácskozás az agrárgazdaság gépesítéséről. Szent István Egyetem, Gödöllő. *Előadás-Kiadvány (előadások és konzultációs témák tartalmi összefoglalói* ISBN: 963 611 406 4) – Agrár-műszaki alap kutatások Szekció, p. 15.
- [4] Zoltán Gulyás és György Dimitrievits (2004): „Versuche mit angewandten verlustmindernden technischen Lösungen beim Spritzen”. Conference: Agricultural Engineering: VDI-Tagung Landtechnik 2004 Dresden, 7. und 8. Oktober 2004. VDI-MEG Precision Farming p. 455.-462.(VDI-Berichte Nr. 1855, 2004)

## EFFECT OF THE DRYING PROCESS ON THE CHARACTERISTICS OF THE CORN BATCHES

J. Csermely – M. Herdovics – A. Csátár  
Hungarian Institute of Agricultural Engineering, Gödöllő

### Object of the research

Object of the research was to determine the aggregation characteristics of the corn in the course of drying.

### Material and method

The examinations were carried out with three varieties of corn that were known in agricultural production within the limit of the following moisture content:

– Mv Tc-277 hybrid	3.5-24.8 %
– Mv MARA Tc	3.5-29.6 %
– NORMA Sc	3.5-34.4 %

Measurements were carried out in operative circumstances, in exiccator, in laboratory drying oven resp. Measurements of volumetric mass and bulk density happened by sampling of 1,000 g of samples by three times repetitions. At the measuring of bulk density the method of liquid displacement was applied. The operative drying measurements were accomplished by MECMAR and STELA type of thick grain layer, material circulating driers at 105-110 °C drying medium temperature. The same temperature was applied in the case of the MGI type laboratory drying oven, equipped with AHLBORN type measuring and data collecting system with automatic regulation system. In this case the thick of layer could be regulated within 4 x 20 cm and 10 x 10 cm measuring limit.

Determination of compressive strength was carried out by INSTRON-5581 type tester, equipped with special instrument at 30 kN compressive force. (Fig. 1.)

Adjustment of the tester:

- pre load: 100 N
- dislocation of the slider, belongs to it: 25 mm/min
- load: up to 30,000 N
- dislocation of the slider, belongs to it: 1 mm/min

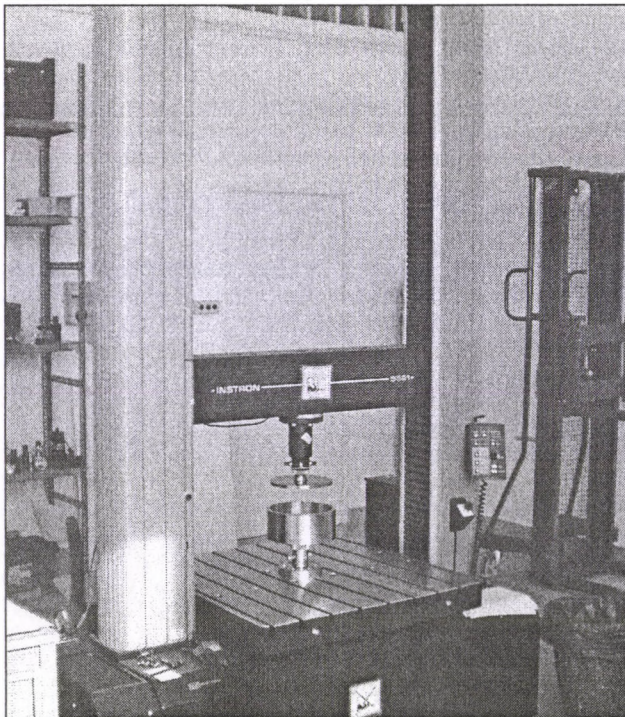

Fig. 1 Instron-5581 type tester



Fig. 2 Measuring instrument

Limit value of the applied force meter cell is 50 kN, its measuring accuracy is 0.5 % related to the measured value, from 500 N up to 50 kN. For determination the mass of corn a Kern 572 type weigher was used. Its measuring accuracy was 0.1 g. Mass of each samples were 1,000 g. Diameter of the measuring instrument was 200 mm, while its height was 80 mm (see Fig. 2.). Calculation principle of the mechanical characteristics is shown on Fig. 3.

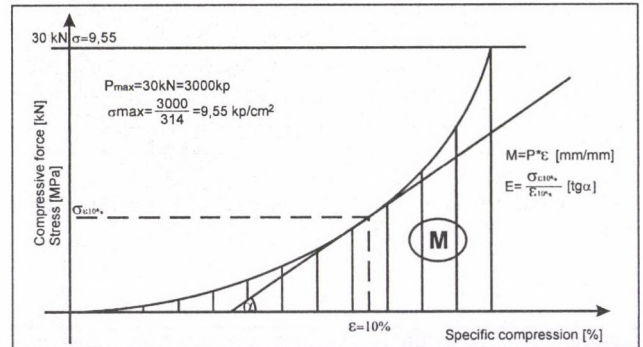

Fig. 3 Explanation of the mechanical characteristics

### Results and conclusions

#### In terms of the physical characteristics

- **Drying process** can be described by exponential coherences with very precision in 29.5-12.0 % range of moisture content during operative drying examinations.
- The **average drying velocity** is 2.10-2.20 moisture %/h beside 110 °C medium temperature in the case of intermittent-duty, thick layed, material circulating driers. The quasi **corn temperature** does not exceed the 50 °C value.
- The **volume mass** of the aggregation is continuously increasing from 640-680 kg/m<sup>3</sup> up to 730-750 kg/m<sup>3</sup> limit value and reaches its maximum value near the 13-15 % of equilibrium moisture content during the drying process, deriving from the shrinkage and depending on variety and the starting moisture content of the corn. At over drying (10-12 % of moisture content) the volume mass of the aggregation begins to decrease down to the value of 705-730 kg/m<sup>3</sup>. In the case of radical over drying (3.5-7.7 % of moisture content) this value will decrease down to 680-710 kg/m<sup>3</sup> value (see Fig. 4.).

- The **aggregation volume** of the grain corn will radically decrease with 10-12 %, down to the 14-15 % of equilibrium moisture content then following it will slow down by the effect of the drying. The shrinkage comes to an end between 3.5-7.7 % of moisture content. From the results we can be drawn the conclusion that in the above mentioned moisture content range the so called combined water removes from the crop. The grade of shrinkage comes to an end at 13.0-13.5 % of moisture content in this range, reaching the maximum value (see Fig. 5.).
- The **aggregation density** of the examined hybrids will continuously decrease during the drying process and the value of it is 1.0-1.15 kg/dm<sup>3</sup> at the equilibrium moisture content. Measure of the decreasing is 9.3-9.9 % (see Fig. 6.).

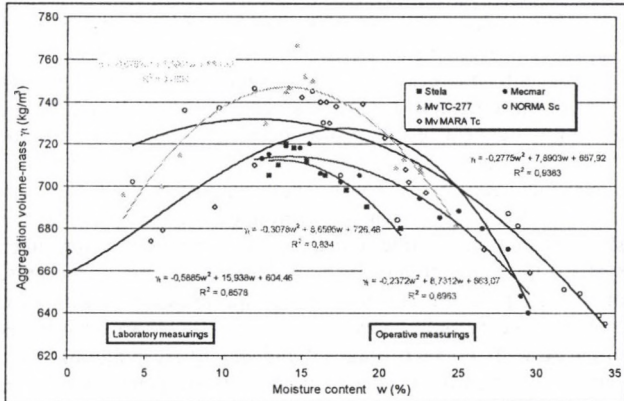

Fig. 4 Coherences between the mass volume of the aggregation and the moisture content of the grain corn

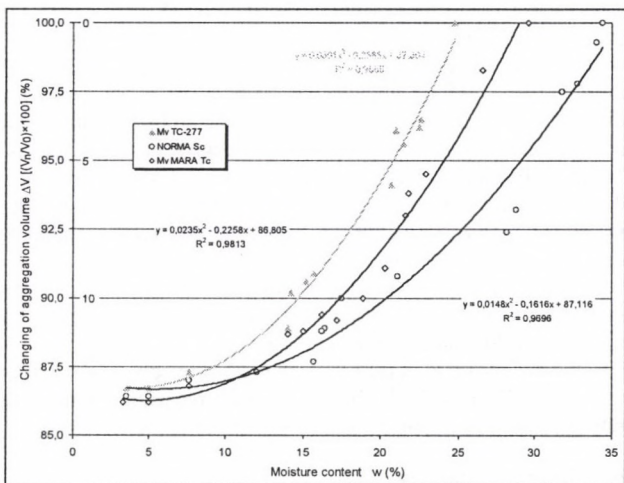

Fig. 5 Changing of aggregation volume of the grain corn in the course of drying (%)

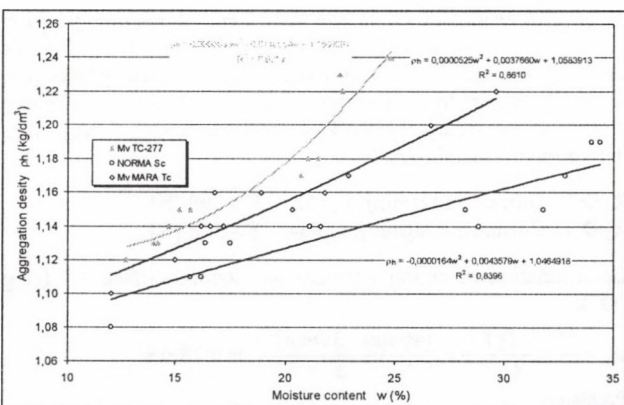

Fig. 6 Coherences between the aggregation density and the moisture content of the grain corn

## In terms of the mechanical characteristics

- The results of the mechanical examinations will make known within the **drastically overdried**, 3.5-13.4 %, moisture content range.

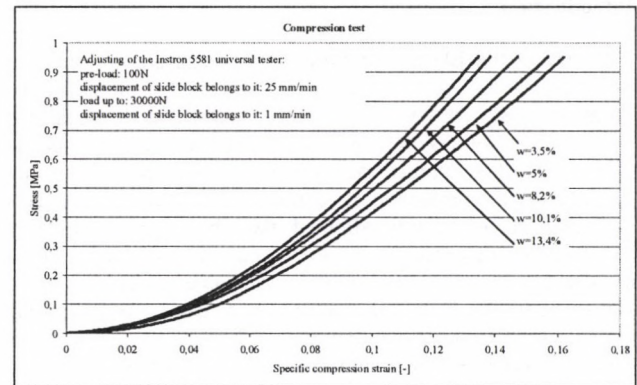

Fig. 7 Results of the compression tests plotted against the moisture content

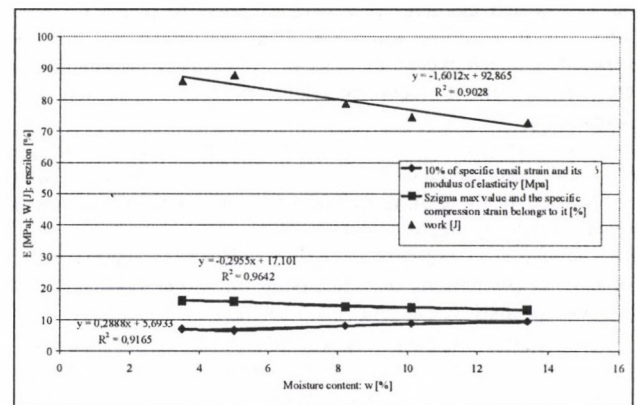

Fig. 8 Results of the mechanical characteristics plotted against the moisture content

- The **specific compression strain** is raising moderately between 13.3-16.1 % range of moisture content, following its decreasing (see Fig. 7.).
- The **modulus of elasticity**, belongs to the 10 % of specific compression strain decreases from 9.45 MPa to 7.04 Mpa by the effect of the drying (see Fig. 8.).
- The **amount of the compression work** increases from 72.7 J to 85.9 J by significant increase of the measure of overdrying (see Fig. 8.).

## Preferences

- [1] Sitkei Gy.: Mezőgazdasági anyagok mechanikája. Akadémiai Kiadó, Budapest 1981.
- [2] Sitkei Gy. – Csermely J. – Fenyvesi L.: General regularities of compaction for viscoelastic agricultural materials. AgEng '92 Uppsala 467-493 p.
- [3] Fenyvesi L.: Mezőgazdasági termények sérülésvizsgálata. Akadémiai Kiadó, Budapest 2004.
- [4] Csermely J. – Herdovics M.- Pázsiczki I.: Environmental and Heat aspects of Cereal Drying. 4th CHOPS, Budapest 2003/Vol 2, 7-11
- [5] Csermely J. – Herdovics M. – Csátár A.: Connections among the heattechnical and physical characteristics of the maize drying processes. AgEng, Louven 2004 CD Rom 1092-1093.

## DEVELOPMENT OF LEAKAGE CONTROLLED FLOW DIVERSION SAFETY VALVE

E. Forgács – J. Csanádi – C. Hodúr – G. Szabó  
Faculty of Food Engineering, University of Szeged

### Introduction

Our joining the EU on 1st May 2004 means possibilities and challenges as well as the so-called globalization. Simultaneously we have to note reluctantly that the legal and official prescriptions and regulations may become inconsiderate tools of market competitions sometimes. Naturally these are destined for the protection of customers, but unready producers as market persons can be affected like a bolt from the blue by the demands of prescriptions or regulations indicated perhaps by competitors on the market – as some precedents have happened so far. However, such products can be found on the market of the Union after some years of tolerance, which suit in every respect the very severe conditions created in connection of the production and marketing of foods.

For home milk processing plants such a new challenge is to ensure warranted safe heat treatment of raw milk in such a manner which excludes any kind of possible forms of after-infection. In addition suitability of applied procedure must be verified. The achievement of this is not realizable in most home creamery without technical development, innovation and investment.

New sanitary prescriptions related production and marketing of raw and heat-treated milk as well as milk products were established in the **Communiqué of the Council of European Communities** (Directive 92/46, 1992).

The Appendix B and chapter V of this directive deals with the **special requirements for licensing of heat-treating and processing institutions** and describes that:

- "heat treating and processing institutions must possess at least:*
- (f) *a heat treating equipment approved or permitted by authorities responsible, which is equipped with:*
  - *temperature controller,*
  - *recording thermometer,*
  - *automatic safety device, which prevent the insufficient heating,*
  - *suitable safety system, which prevents mixing of pasteurized or sterilized milk and milk heated insufficiently"*

For instance, pneumatic reversing valves built-in behind holding section of pasteurizer are destined for the fulfillment of above recommendation. According to experiences of hygienic controls, valves of such function are absent in the system in several places. If there are some, this does not satisfy demands on exclusion of all possibilities for reinfection, or they are cut out. But such valves have not existed so far for small-scale devices and for small tube diameters.

### Effect of operation of the diversion valve on pasteurization

The task of reversing valve is to secure the stream of milk in alternative bifurcating directions from heating or holding sections of the pasteurizer. The aim of this operation is to prevent the flow of milk of inadequate quality in return tract of the pasteurizer where thermal energy of hot milk is used for preheating the incoming cold milk. Because an intensive heat exchange also takes place in this tract, hot milk quickly cools to such temperature that system infecting microbes can cause spoilage by getting into the milk destined for packing or following use.

Valves are usually controlled with automation using signals of temperature sensor and their automatic change occurs by remote control. Most of all operation of such valves is worked out by means of compressed air.

Critical conditions of valve operation:

- Accuracy of temperature signal coming in the controller,
- Accuracy and reliability of control program in the built-in system,
- Adequacy and authenticity of operating air and/or mechanic elements,
- Suitable flow conditions inside the valve.

In the best, case reversing valve is used during heating up of the system, at the end of pasteurization and by washing, respectively. Its operation is inevitable in these steps of production to prevent after-infections or mixing of the milk with other materials (e.g. washing solutions).

After-infection is the most dangerous problem during heating up of the system, because milk does not achieve its required germicidal effect yet, so return tracts can be considerably infected. Infection can be resulted, when some kinds of defects arise in the operation or tightness of the valve. A continuous leaking is frequent resulting from packing defects in the case of valves without leakage control. This is the most dangerous defect, because it is hidden and both outputs of the system are infected. Very significant germ propagation can occur in the stagnant milk in the tract out of use which may threaten other systems later. Infection of the return line of the milk is the most dangerous problem during heating up, because in this case infection occurs under slow flow velocity. There are such tracts in the pasteurizer where stagnant and slowly escaping milk may cause deposits, which can be removed by subsequent high flow velocity only after longer time.

Automatic reversal of suitable heat treated milk into the return tract will sooner or later wash away the infective flora from the system. In fact infection will be diluted so much that it will not cause further trouble. Milk of expected good quality will continuously be infected by centers originating from heating until required dilution is produced. Milk quantity necessary for dilution is very difficult to be estimated, therefore solution can be attained only by application of leakage controlled valves. Their application excludes infection of returning milk. Packing defect is indicated simultaneously by milk leaking from the valve in a distinctly visible. So defect can be removed quickly and safe pasteurization can be continued.

Unfortunately leakage controlled valves are used typically in pasteurizers of high-efficiency, such valves are rarely found in machines of low- and medium-efficiency.

We have developed leakage controlled flow diversion safety valves (**LFDV**) with double valve seat presented below, to satisfy above requirements in pasteurizers of low-efficiency.

### Results and discussion

Powers and pressures necessary for perfect closing of valve disks and seats in valve constructed were determined on the basis of registered data in the first step. In starting position valve disk and seat (1, 2) are closed, pressure necessary for closing is provided by spring force. There are two springs ( $R_1$ ,  $R_2$ ) in the valve. In starting position spring  $R_2$  keeps the valve closed, while spring  $R_1$  works against it. Spring forces were determined from tables:

$$R_1 \rightarrow D=16[\text{mm}], d=2[\text{mm}], L_o=52 \quad F_1=198 [\text{N}]$$
$$R_2 \rightarrow D=34[\text{mm}], d=4[\text{mm}], L_o=54 \quad F_1=523 [\text{N}]$$

Determination of acting pressure on closing surface  $A_1$  (ring "O"):

$$A_1 = \frac{(D_2 - D_1)^2 \pi}{4} = \frac{(40\text{mm} - 39\text{mm})^2 \pi}{4} = 0.78\text{mm}^2$$

Pressure:

$$P_1 = \frac{F_2 - F_1}{A_1} = \frac{523 - 198}{0.78\text{mm}^2} = 416\text{kPa} \approx 4.16\text{bar}$$

### Determination of velocities

Flow cross section:  $A = \frac{d^2 \pi}{4} \text{ [m}^2\text{]}$

$d = 20 \text{ [mm]} = 0,02 \text{ [m]} \rightarrow A = \frac{0,02^2 \pi}{4} A = 0,000314 \text{ [m}^2\text{]}$

Liquid flow ( from instrument reading ):  $Q = A \times v \text{ [dm}^3\text{/h]}$

Velocity:  $v = \frac{Q}{A \times 1000 \times 3600} \left[ \frac{m}{s} \right]$

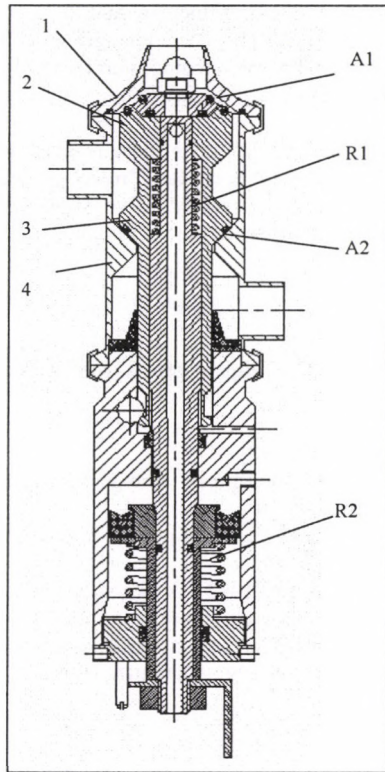

Fig. 1 The cutaway view of valve

After change the valve is closed at the bottom, an air pressure of 6 bars adds to spring force, so a force  $R_1$  + force originating from air pressure works against  $R_2$ . (Figure 1.)

Pressures and liquid velocities in the valve were modeled with computer program. Velocity values evolving in LFDV is plotted in the left-hand figure. Liquid pressure values are illustrated in the right-hand side and in the middle figures, respectively.

Projected valve on the basis of calculations and modeling was found as required.

After production of the valve we had to perform actual tests, from which it could turn out whether the LFDV worked according to prescriptions and projecting.

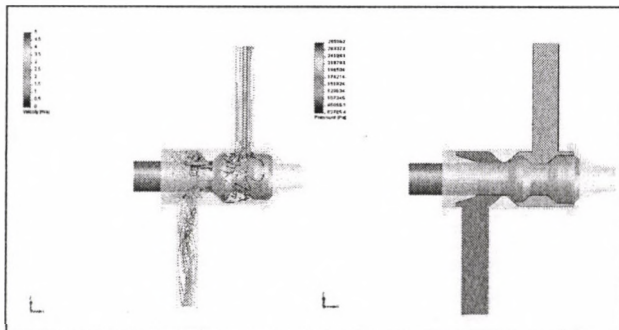

Fig. 2 Changing of the flow velocity and pressure in the valve

Diagram of differences between input and output liquid pressures can be seen on the 3rd Figure.

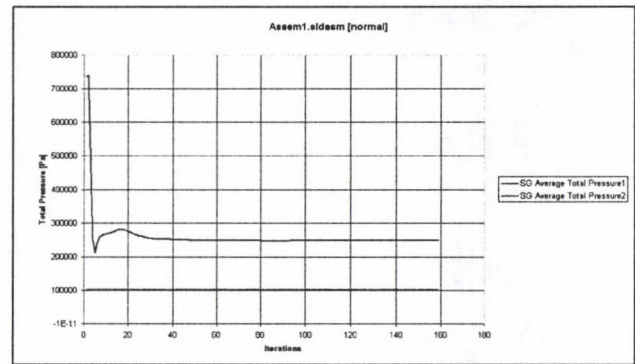

Fig. 3 Difference of liquid pressure at the inlet and outlet of valve

### Evaluation of tests

Measurements were performed at liquid temperature of 15 °C (in the present case water was used as liquid, at revolution of 2950 min<sup>-1</sup> and at gradually increased pressures.

At higher working pressures leakages occurred during tests. The valve did not close perfectly and liquid appeared in both discharge holes, since tract were opened into each other. This defect could be developed because of low force of spring  $R_2$ . In addition other leakage problems aroused, too.

- Problem of imperfect closing originated from spring force in the cylinder, which was insufficient to switch the valve completely at higher liquid pressure, the two liquid tracks were only opened into each other.

- Contact surfaces between valve disk and seat were formed at an inappropriate angle. As a result, rings "O" were damaged and leakage defects appeared.

- Double valve seat was dislocated because of its insufficient guidance, which caused further leakage problems.

- One extra boring M was fabricated in the cylinder. Its inner sizes were transformed for solving the two-way air input and with that spring force could be helped pneumatically. So working cylinder of double operation was practically applied instead of a cylinder with single operation, working pneumatically with spring operation. Because of cylinder alteration its head had to be modified, too. Distance pieces in the cylinder had to be substituted with one on which two O rings could be mounted (double packing) for producing pneumatic guidance back and forth.

- Angles of contact surfaces between valve disk and seats were also for more stable bearing and packing.

- Valve seats in valve case were transformed so that they could guide the double valve disk.

Assembly drawing of modified valve is presented in the fig. 4.

- A slot for a slip ring had to be formed in the cylinder to eliminate metallic contact between double valve disk and cylinder surfaces.

- Modification of angles of contact surfaces between valve disk and valve seats was continued for even more stable bearing and packing.

- Lower pipe junction on the valve case had to be located 1-2 mm deeper, so liquid could completely leave the valve. Slots for ring "O" had to be formed radial, by its means rings "O" would be seated more precise into the slot ensuring better packing and preventing impurities from penetrating under the ring.

New measurements were performed at 15, 75 and 90 °C liquid temperatures and at 2950 min<sup>-1</sup> pump revolution after elimination of defects. The performed modifications enabled the development of a valve operating satisfactorily on the basis of measurements.

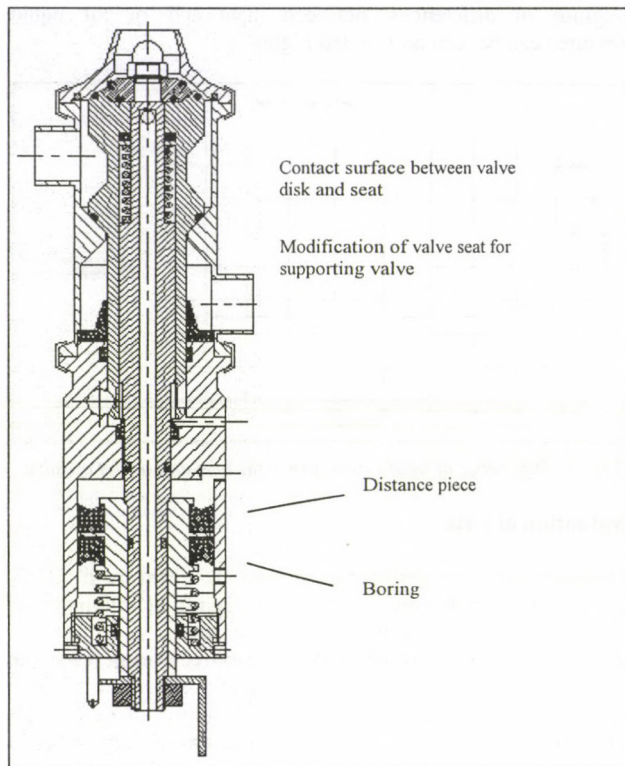

Fig. 4 The cutaway view of the modified valve

### Conclusions

EU directive regarding to safe heat treating of milk demands building such machine parts in present pasteurizers which can guarantee food safety excluding the after-infection. Provisionally such safety valves are available only in constructions produced for equipments of high-efficiency and for great tube diameters. Operation of reversing valve prepared according to our plans was investigated in a test equipment.

Measurements were performed in several series in the test equipment projected and built for this purpose. Liquid pressure was gradually increased at constant pump revolution of 2950

min<sup>-1</sup> and at 15, 75 and 90 °C temperatures. At the bench valve operating factory-like was modeled with several repetitions and alternations of valve position.

Liquid flow was developed with pump in the pipe line of 20 mm diameter in test measurements. Liquid streamed from the tank through volume flow meter to LFDV then back to the tank. Pressure, temperature and liquid flow was continuously measured. Measuring results were recorded with recorder for subsequent detailed analysis and evaluation.

On the basis of measurements performed after defect corrections and valve modifications it can be established that operation of LFDV meets the expectations. Pressure of the liquid streaming in it does not fluctuate and its velocity remains within prescribed values. The valve changes quickly, perfectly and in a leak-proof way. It is verified with EU qualification KLS 5/04 by Bundesanstalt für Milchforschung in Kiel, which is at our disposal.

On the basis of our results the project realized with the aid obtained in the scope of European Project is deemed to be successful. The developed safety valve is recommended to home and foreign small-scale plants for purchase and installation.

### References

- [1] Ambrus, V. 1987: Tejipari gépek. Mezőgazdasági kiadó, Budapest
- [2] Balatoni, M., Ketting, F.: Tejipari kézikönyv. Mezőgazdasági kiadó, Budapest 1981.
- [3] Bardach S. (1992): Tejipari szakgéptan. KÉE egyetemi jegyzet, Budapest
- [4] Fenyvessy J., Csanádi J. (1998): Tejipari technológia. JATE SZÉF jegyzet, Szeged
- [5] 92/46/ EGK Irányelv (1992): A nyerstej, a hőkezelt tej és a tejalapú termékek gyártásával és forgalomba hozatalával kapcsolatos egészségügyi előírások megállapításáról. Európai Közösségek Hivatalos lapja, 1992. június 16, Bruxelles

### Acknowledgement

This work was supported by EU and Hungarian government Project number: GVOP3.1.1. 2004-05-0275/3.0

## MICROWAVE TREATMENTS OF LIQUID FOOD

J. Kiss – P. Sembery

Szent István University, Gödöllő

### Introduction

The main aim of preservation processes is to provide food safety during the permitted consumption time. It means that food products have to meet quality and safety requirements at the same time. Food safety mainly aims at keeping the product free of any bacteria and extraneous matter that can cause infection or poisoning. Quality on the other hand is an abstract in marketing meaning that the colour, the composition, the packing etc. of the product have to meet the demand of consumers and the related requirements.

Pasteurization is a mild preservation process aiming to kill vegetative microorganisms and prevent the product from infection, but at the same time it also aims to keep the original attributes of the product (Minimal Processing). Microorganisms can only multiply in a certain temperature range, higher temperature kills them. The efficiency of the treatment also depends on the holding time in addition to the applied temperature. (Várszegi, 2003). The heat penetration curve (Figure 1) clearly illustrates that the heat treatment of food products consists of three phases: first of all the product has to be heated – in the shortest possible time – to the temperature ( $T$ ) of the treatment (holding); then it has to be held at this temperature for a certain time ( $t$ ); then it has to be cooled down to the temperature of storage or the next phase of processing. The higher the temperature and the shorter the time of the treatment is, the better the quality of the product is. The combination of time and temperature has to be chosen in a way that the treatment should kill microorganisms more quickly than the product loses its physical attributes. (Várszegi, 1997).

There are several possible combinations of temperature and holding time in the case of milk. The traditional – or quick pasteurization – method is a process when milk is heated to 72 °C and then kept at this temperature for 2 minutes and then cooled back quickly. Small scale breweries usually heat the products to 60 - 64 °C by applying water bath or steam, the holding time is 20 minutes. Our experiments aimed to achieve the above-mentioned parameters by microwave treatment.

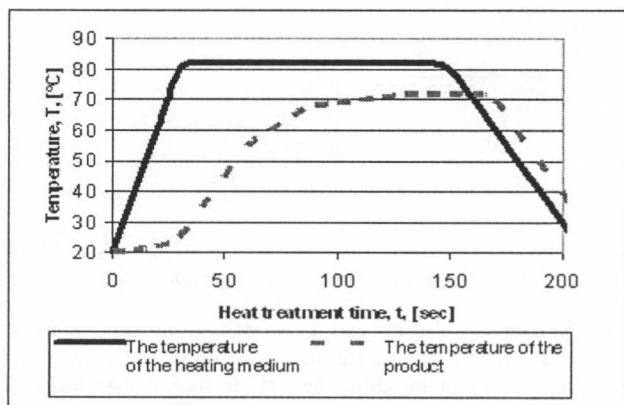

Fig. 1 The heat penetration curve

Microwave processes are mild heat treatments. During electromagnetic or dielectric treatments (heating) the material is put in a high frequency alternating current electromagnetic field. The dielectric field sets the particles of the material in motion (internal heat production), the particles are reorganised and a part of their kinetic energy is converted to heat. The temperature of the material increases (works as a dielectric). One of the most important advantages of applying microwave is that the heat treatment is quick, therefore it causes less damage in the nutritive value of the product and results in better quality. However only a small branch of the food industry has

successfully made use of the advantages provided by microwave. Only a few experiments have been carried out in the field of the microwave preservation of liquid food and the implementation opportunities of the new processes (Géczi et al, 2004; Géczi G., Sembery P., 2005).

This research focuses on working out a general technology for the pasteurization of liquid food products (fruit juices, beer, milk, tomato juice) by setting up a periodically and a continuously operating microwave device.

### Material and methods

Taking into account the above-mentioned requirements for pasteurization some research was carried out in a laboratory to investigate microwave treatment. Microwave pasteurization was implemented in two different ways. In the case of periodical treatment the product was put in a household microwave oven (AT314) and was heated for a certain period of time. In the case of continuous microwave treatment a microwave oven of the same type was rebuilt so that it was possible to continuously drive the product in and out of the oven. Our previous investigations had proved that significant energetic differences between the traditional and the microwave treatment only occur in the heating phase so our research concentrated on examining that part of the treatment. Our research did not deal with the holding and the cooling phases of pasteurization. The proper holding phase was provided by applying simple insulation.

During the investigation of periodical microwave treatment the product of given volume  $V$  ( $m^3$ ) was put in the electromagnetic field of a household microwave oven (Whirlpool AT314) then the heating phase was examined at 1000 W of power. The temperature of the product was continuously measured at eight different points of the material at the same time by applying an ALMEMO 2590-9 data logger with Cu-CuNi thermocouples.

During the investigation of continuous microwave pasteurization, heat-resisting spiral tubes (connected to each other) were driven in the cavity of a rebuilt microwave oven (Whirlpool AT314). A pump was circulating the product in the spiral tubes while the microwave oven was operating at 1000 W of energy. The volume of a spiral tube was  $\sim 22$   $cm^3$ . The higher the number of the tubes in the cavity was the more it was possible to regulate the time that the product spent in the electromagnetic field. Temperature was measured (ALMEMO 2590-9) at several points of the product both in the heating and the cooling phase.

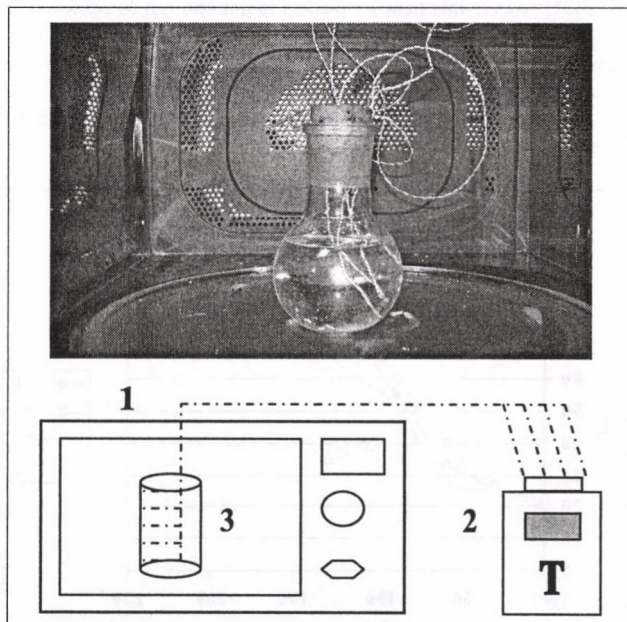

Fig. 2 Periodical heating

(1-microwave oven, 2-temperature meter, 3-sample holder)

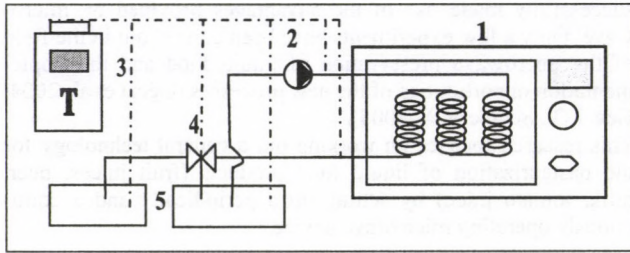

Fig. 3 The measuring circle of continuous heating (1-microwave oven, 2-circulating pump, 3-temperature meter, 4-switch, 5- holding plates)

## Results

The result of our measurements were illustrated in diagrams. For the time being our investigations have concentrated on milk, beer and distilled water. During our investigations with periodical heating there were significant differences in temperature inside the product when treating larger samples (for example: 2 litres). Temperature differences could have only been equalized by further heating (Figure 4). However further heating would require extra time which means that the microwave process would lose its advantage of being quicker compared to traditional methods. When heating samples of lower volume similar differences in temperature do not or hardly ever occur. Based on the investigations our conclusion is that when applying a household microwave device the main aim of pasteurization (the required temperature at every point of the product) can only be provided if the sample size is maximum 0,5-1 litres. That is the sample size where temperature will be homogeneous and it is also the unit size of the packages of liquid food products (bottles, boxes etc.). Therefore our periodical investigations concentrated on similar small size samples.

At the beginning of the research traditional bottled beer was treated by microwave. Our aim was to heat it to at least 60°C, the time of the heat treatment was increased by 30 seconds each time. Figure 5 shows that in the case of pasteurizing beer of a given volume (500 ml) different heat treatment time provides different temperature. The diagram also shows that about 180 seconds are needed to reach the minimum heat treatment temperature by applying microwave (the initial temperature was 14°C). However this heating period is not enough to achieve the required microbiological effect but longer treatment time may cause damage in the nutritive values of food products. The same investigation was carried out with milk samples of 500ml and 1,5 percent fat content. The results were similar to that of the investigations of beer.

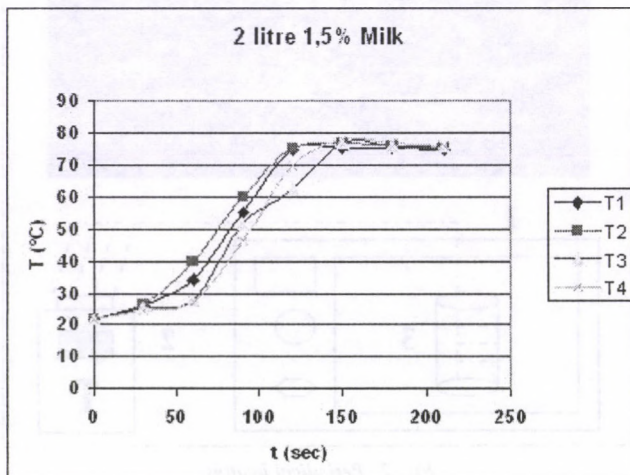

Fig. 4 The changes in temperature

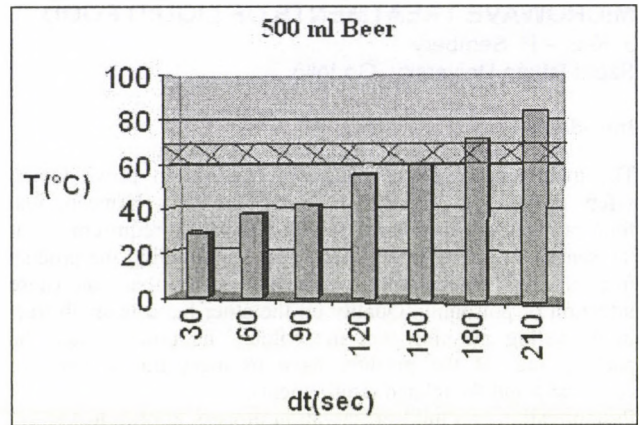

Fig. 5 Temperature in beer samples treated for different periods of time

The results show that microwave lived up to our expectations because it successfully provided the required pasteurization temperature (the method for sterilising the packing is also available). However when treating larger samples the distribution of temperature is inhomogeneous in the material. Due to the power of the magnetron and the size of the cavity the quickness of the process only makes microwave treatment competitive with traditional methods if the size product does not exceed a certain limit.

Then our investigations were extended to determining the temperature increase in unit time as a function of the quantity of the material when heating the product (Figure 6). The results led to a general diagram which shows that when pasteurizing packed products ( $V \leq 1$  litre) by applying a household microwave oven, if the time of treatment is known then the vertical axis shows the achievable increase in temperature

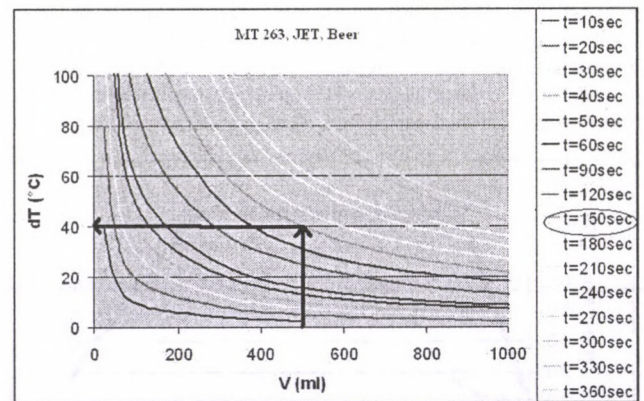

Fig. 6 Temperature increase as a function of volume

Our experience is that the less the quantity of the product in the microwave field is the shorter the time necessary for achieving the same temperature difference is. It means that the best application of periodical microwave pasteurization is to treat small, packed products (for example: bottled beer or cans of soft drinks)

However there are liquid food products that are not pasteurized in a packed form, for example plate pasteurizers are the most popular for treating milk in the dairy industry. Our continuous microwave pasteurizer was set up similarly to milk pasteurizers. Table I shows the result of heating when continuously pasteurizing 2000 ml milk compared to the result of periodical pasteurization. Five glass spirals ( $\sim 110 \text{ cm}^3$ ) were put in a cavity where the product was circulated by a pump. Temperature was only measured outside the microwave field in order to eliminate the disturbing effect of the magnetron. The distribution of temperature in the product was homogeneous

because the quantity of the material was small and circulation was favourable. Drawing the conclusion it is clear that continuous pasteurization – because there is a smaller quantity of product in the microwave field at a given moment – provides more favourable results than periodical pasteurization.

**Table 1** The comparison of continuous and periodical microwave heating

Milk 1,5%	Continuous			Periodical		
$V$ [ml]	2000					
$\Delta T$ [°C]	51,1	51,2	51,6	51,4	50,9	52,1
$t$ [min]	8,3	8,3	8,5	10,1	9,8	10,1

### Conclusions

Our research proved that microwave technology is very useful in pasteurization because it can provide the required temperature and it is considerably faster than traditional methods. However it has to be taken into account that the quantity of the product to be pasteurized is limited. The results of our investigations show that a maximum of 1 litre of material can be held in the cavity at a given moment during heating (because of the power of the magnetron and the size of the cavity). It is very likely that the distribution of temperature will be homogeneous in the product and the process will be competitive with traditional methods (quickness, energetic concerns etc.).

Our final conclusion is that the pasteurization of liquid food can be implemented by applying microwave technology independently from the fact that it is a packed product

(periodical pasteurization) or it is a higher quantity product without packing (continuous pasteurization). However our research has to be extended to investigating the microbiological effects of microwave in order to prove that our conclusions are correct.

This research is subsidized by the Hungarian Scientific Research Fund (tender No. T043320).

### References

- [1] George M.R., 1992. A Review of the applications of microwave energy in food processing. Technical Bulletin No.89, Campden Food & Drink Research Association.
- [2] Géczi G. – Sembery P. – Kovácsné L. M. – Kiss J., 2004. Folyékony élelmiszerek mikrohullámú kezelésének vizsgálata, VI. Nemzetközi Élelmiszertudományi Konferencia, Szeged ISBN 963 482 677 6 6p.
- [3] Géczi G. – Sembery P., 2005. Mikrohullám az élelmiszeriparban. Áram és technológia III évf. 2005/1, ISSN 1588-869X, 19-21 p.
- [4] Kiss János – Dr. Sembery Péter – Dr. Géczi Gábor: Mikrohullámú pasztörözés és energetikai vizsgálata, Műszaki Kémiai Napok, 2005 Veszprém,
- [5] Narziss L. (1981): A sörgyártás. Mezőgazdasági Kiadó, Budapest, 346 p.
- [6] Várszegi T. (1997): Az élelmiszer-ipari műveletek hatása a termék minőségére. Gödöllő, 234 p.
- [7] Várszegi T. (2003): Elsődleges termék feldolgozás. Szakmérnöki jegyzet, SZIE Gödöllő, 155 p.

# DETERMINATION OF THERMAL PARAMETERS UNDER INDUSTRIAL CONDITIONS

F. Eszes – R. Rajkó – G. Szabó

Faculty of Food Engineering, University of Szeged

## Introduction

The estimation of the thermal diffusivity from heat penetration curves is a general practice in the literature of the heat treatment. It can be solved with a fast computer very quickly. Nevertheless we have to think about the use of the obtained results in further calculations so the accuracy is a fundamental requirement. Investigating the published values a real wide range can be observed. We summarised it for meat products in Table 1. It can be observed outlying values (e.g., CARCIOFI et al. 2002), but the most values are in the range of about  $1.2 \cdot 10^{-7} \div 1.4 \cdot 10^{-7} \text{ m}^2/\text{s}$ . Our aim was to investigate why the differences in literature data exist.

Table 1 Thermal diffusivities of meats and meat products

Author and publication year	$a \cdot 10^7 \text{ [m}^2/\text{s]}$	Notice
TSCHUBIK and MASLOW (1973)	1.2	Ham
DICKERSON and READ (1975)	1.2-1.3	Beef ham
RIEDEL (1969)	1.2-1.43	Calculated from water content 10-70°C
LÖRINCZ and LENCSEPETI (1973)	1.2	Cured meat
SANZ et al. (1987)	1.1-1.3	Lean meats
MITTAL and BLAISDELL (1984)	1.165-1.325	Meat batter
HUANG and MITTAL (1995)	1.6-1.9	Meat ball, during cooking and frying
MCDONALD et al. (2002)	1.15-1.207	Cooling cooked beef
MITRA et al. (1995)	1.28-1.52	Mortadella in hot smoking and cooking chamber
KÖRMENDY (1991)	1.27	Ham sausage
KÖRMENDY (1991)	1.42	Cooked sausage „Veronai”
KÖRMENDY (1991)	1.74	Potted meat
KÖRMENDY (1991)	1.93	Sports spread with cheese
CARCIOFI et al. (2002)	2.4	Mortadella, in hot smoking and cooking chamber

## Methods and materials

For the calculation of thermal diffusivity from chemical composition we used relationships of MILES et al. (1983), CHOI and OKOS (1986) and RIEDEL (1969), MARTENS (1982). The heat penetration curves were evaluated by Ball method and the thermal diffusivity calculated by RAMASWAMY (1982). As curve fitting methods we used classical least squares and robust regression (RAJKÓ, 1994). The aspects of conductivity and conductivity were investigated by Nusselt function for free convection. The convection limit was considered as  $Ra$  (Rayleigh number) = 1000 (MIHEJEV 1987). The thermal parameters of fats were taken from tables of KISS (1988). For the determination of the heat transfer coefficient we used the infinite series solution of Fourier differential equation (WONG 1983). For comparison with the temperature dependence we used the finite different method with finite surface heat transfer coefficient following TEIXIERA et al. (1969).

## Results

The highest value in Table 1 derives from CARCIOFI et al. (2002). They explained it by the change of the thermal parameters due to the protein denaturation about 70°C. The heat

penetration curves of Ball and Fourier would have been broken earlier because the myosin fraction at 50-55°C and sarcoplasmic protein about 60°C already denatured which does not happen in all layers at the same time. However the reason is different. According to our experience the moist heat transfer coefficient of moist air stream in cooking chamber can be expected about 200-400 W/m<sup>2</sup>K. RAMASWAMY et al. (1983) measured 10000-15000 W/m<sup>2</sup>K surface heat transfer coefficient for pour steam condensation which can be decreased to 1000 W/m<sup>2</sup>K in case of 50% condensate content. Thus Eq. (1) appeared in CARCIOFI et al. (2002) is not proper for the estimation of thermal diffusivity. If we recalculated  $f_h$  value using the thermal diffusivity given by CARCIOFI et al. (2002), 45-52 min can be obtained.  $f_h$  values for our cooked sausages similar in size and composition are summarised in Table 2. The values obtained by our calculations are about two times greater, but the standard deviations correspond to the published values (SINGH 1982). If we calculate the thermal diffusivity with our  $f_h$  value, then we are in the region of  $1.29 \div 1.48 \cdot 10^{-7} \text{ m}^2/\text{s}$  which is the most frequent region in Table 1. The same is true for the calculations with the 200-400 W/m<sup>2</sup>K finite surface heat transfer coefficient. The procedure of CARCIOFI et al. (2002) neglects the finite surface heat transfer coefficient, as used by others as well (JARAMILLO-FLORES AND HERNANDEZ-SANCHEZ 2000). They obtained high values similar to the water ones.

Table 2 Ball slope indexes for cooked sausages ( $f_h$ )

	Sausage „Olasz”	Sausage „Veronai”	Sausage „Vadász”
Mean	84.5	85.4	84.2
Standard Deviation (SD)	7.7	6.5	6.1
Relative SD	9.2	7.7	7.2

The high thermal diffusivity values for foods, higher than ones of water, can not be accepted. Although the thermal conductivity, specific heat and density are different for fat, water and protein the water has the highest thermal conductivity and protein and fat has smaller ones. If we take into account the ratios of the chemical compositions of cooked meat products (for water 60-70 %, for protein 10-12 %, and for fat 18-20 %, resp.), then the fat and protein should decrease the thermal diffusivity values, therefore the thermal diffusivity of the products has to be smaller than the water ones in spite of that smaller specific heat and about the same order of density (Table 3).

Table 3 Thermal parameters of sausages and its constituents

Product	Thermal diffusivity [m <sup>2</sup> /s]*10 <sup>-7</sup>	Thermal conductivity [W/mK]	Specific heat [J/kgK]	Density [kg/m <sup>3</sup> ]
Sausage „Vadász”	1.401	0.457	3431	950
Mortadella	1.300	0.430	3211	1029
Sausage „Olasz”	1.537	0.500	3758	866
Mean	1.307	0.451	3325	1036
Lean meat	1.307	0.500	3610	1058
Fat	0.961	0.180	2014	930
Water	1.435	0.600	4180	1000
Protein	0.762	0.200	1900	1380

The value of MITRA et al. (1995) is surprisingly in the upper region of the expectable values because of the unrealistic high specific heat (4600 J/kgK) used. The thermal diffusivity calculated from the composition does not support the wide range of figure of KÖRMENDY (1991). If we calculate the thermal diffusivity from the composition according to MILES et al. (1983) we obtain the lower level of the presented published values in Table 1, meanwhile the equation taking into account the temperature dependence show a maximum  $1.5 \cdot 10^{-7} \div 1.6 \cdot 10^{-7} \text{ m}^2/\text{s}$  (Figure 1).

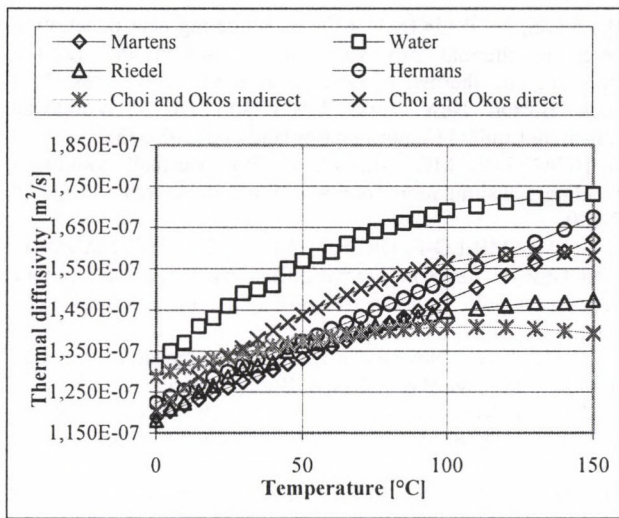

Fig. 1 Temperature dependent thermal diffusivity calculated from chemical composition

The larger thermal diffusivities are often explained by convection. KÖRMENDY (1991) gave 20% larger thermal conductivity and thermal diffusivity as expectable according to Table 3 He explained it by local convection effect in melted fat. If it happens to, then the 3-5 times faster convection heat transfer would cause a break in either Fourier or Ball graphs. It was not experienced in our measurements, because the fat and water are in emulgated and immobilised form in a protein matrix in case of homogenous product. If the fat is dispersed as particle in the product (typical particle size in meat products is 5-20 mm) the convection can be considered as equivalent thermal conductivity in narrow closed space. The product of Pr-Gr values are far under 100 calculated for fully melted fat and the resulting convective heat transfer coefficient is  $0.4\pm 0.5$  W/m<sup>2</sup>K which is much smaller than the  $40\pm 60$  W/m<sup>2</sup>K of water and even than the  $5\pm 10$  W/m<sup>2</sup>K of still air. So the heat transfer intensity is 1/10 of the air which implies very slow heat transfer. The immobilisation is true here as well. The fat is involved in a connective tissue structure having very short distance between the connective tissue membranes. These are only partly disrupted during mincing or chopping. Therefore the convection has only a minor role. It is interesting that the value of DICKERSON and READ (1975) is in the acceptable range although they used variable ambient temperature determination. On the other hand the constant ambient temperature is most frequently used in the heat treatment and in laboratory determination as well. RIEDEL's method (1975) incorporates the temperature dependence of thermal diffusivity of water giving lower and upper limit for the range of 10-80°C, see **Hiba! A hivatkozási forrás nem található.**

The differences in thermal diffusivities are due to the circumstances of the heat penetration measurements. The Fig. 2 show the differences for different ambient temperature and package size having very little filling weight differences (12 lb =5443 g, 11 lb 4891 g) but considerable difference in size (12 lb oblong 105X160X 305mm and 11lb Pullman (110X110X 380mm).

The least squares fitting of FDE ISS gave for the same materials significantly different thermal diffusivity values for holding and cooling. This evaluation is much more sensitive for the violating the presumptions compared to the Ball evaluation (LARKIN and STEFFE 1987).

The extrapolated thermal diffusivity for the core is about  $1.3\cdot 10^{-7}$  m<sup>2</sup>/s. It is in agreement with the expected value in Table 1 and fitted value for 12 lb cans in Table 4. Similar phenomena arose if the temperature sensor placement error increased (Fig. 3).

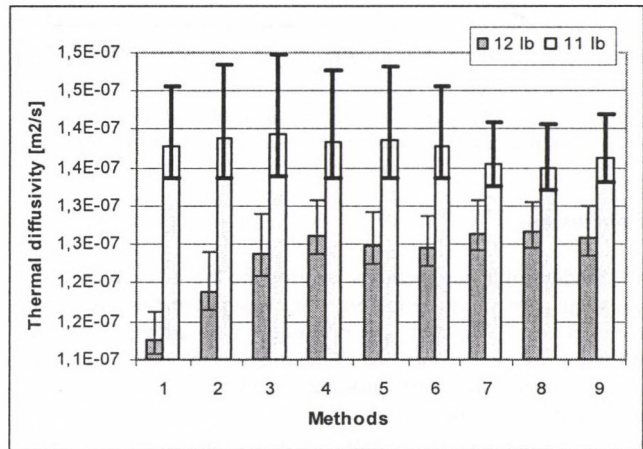
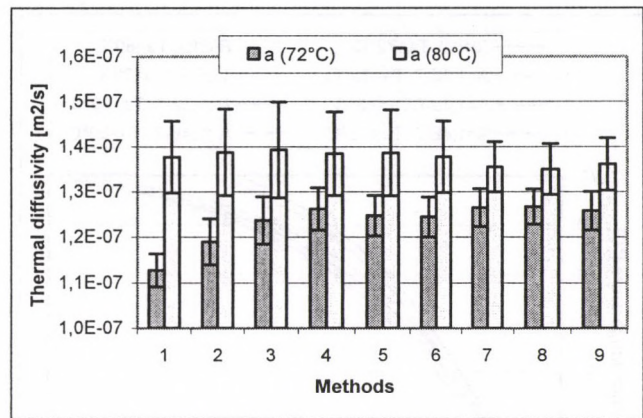

Fig. 2 Thermal diffusivities obtained by Ball method and robust regressions. 72 and 80°C ambient temperature in semi preserved ham packed 12 lb cans (LEFT). 11 lb Pullman and 12 lb oblong cans temperature 12 lb semi preserved ham (RIGHT)

Table 4 Thermal diffusivities obtained by least squares fitting of FDE ISS curve for holding and cooling phases [m<sup>2</sup>/s]

Packaging	Holding phase		Cooling phase	
	Mean*10 <sup>-7</sup>	SD*10 <sup>-9</sup>	Mean*10 <sup>-7</sup>	SD*10 <sup>-9</sup>
11lb Pullman	1,41	5,5	1,16	6,8
12lb Oblong	1,30	7,4	1,13	6,5

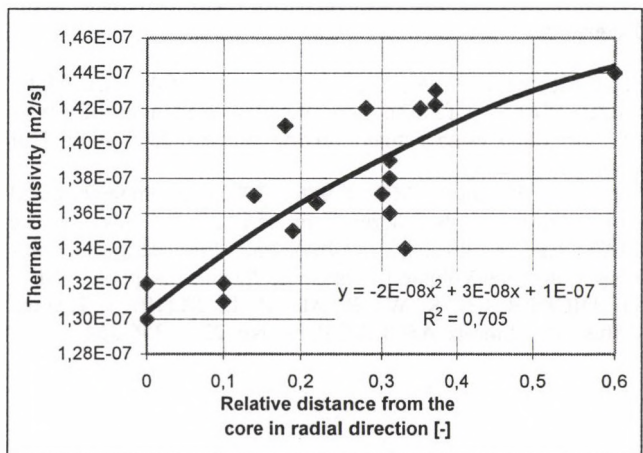

Fig. 3 Effect of temperature sensor placement error on the thermal diffusivity for Parisers (d=80 mm)

The temperature development calculated with constant and variable (RIEDEL 1969) thermal diffusivity were very close to the ones calculated with  $1.3\cdot 10^{-7}$  m<sup>2</sup>/s constant thermal diffusivity (Fig. 4) which correspond to the most frequent region of the values in Table 1.

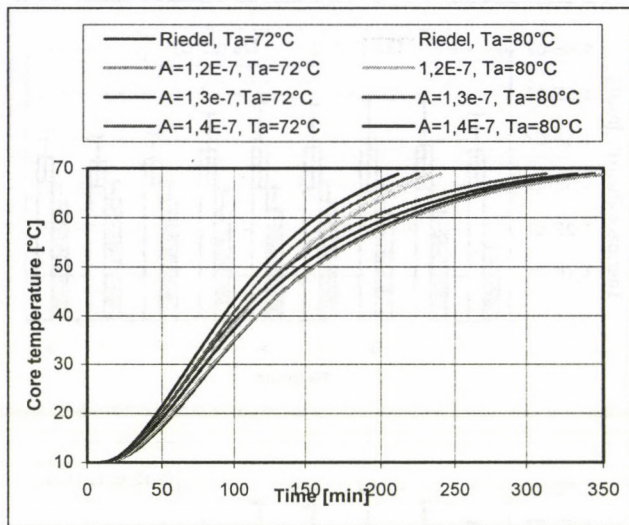

Fig. 4 Temperature development in ham packaged into 12 lb cans Calculated with constant and variable thermal diffusivity (Riedel 1969).

### Conclusions

- The determination methods treating the thermal diffusivity as constant give values reflecting the average temperature during the process. Thus it is possible that different thermal diffusivities can be obtained depending on the heat penetration circumstances for meat products with the same or similar chemical composition.
- The temperature sensor placement error increases the thermal diffusivity. Thus the measuring position affects the thermal diffusivity and the  $f_0$  slope index of Ball. The same is true for the driving force.
- The above mentioned effects arise together many times. Therefore we can say for the practice that the constant thermal diffusivity determination gives good preliminary estimation provided the initial and boundary conditions are not changed and we calculate it for the core. After changing the conditions, shifting could be expected in thermal diffusivity. The temperature dependence should be taken into consideration for the exact (more precise) calculation.

### References

[1] CARCIOFI, B., A., M., FAISTEL, J., GLAUCIA, M., F., ARAGAO, J. B. L. (2002): Determination of thermal diffusivity of mortadella using actual cooking process data. *Journal of Food Engineering*.

[2] CHOI, Y., OKOS, M.R. (1986): Effects of temperature and composition on the thermal properties of foods. In: Le MAGUER, M., JELEN, P. (1986): *Food Engineering and process application Volume 1. Transport Phenomena*. pp. 93-101.

[3] DICKERSON, R. W., READ, R. B. JR. (1975): Thermal diffusivity of meats. ASHRAE Paper No. 2349. 356-364.

[4] ESZES, F., RAJKÓ, R. (2004): Modeling heat penetration curves in thermal processes. In Richardson Ph. (2004): *Improving the thermal processing of foods*. CRC Press Boca Raton Boston New York Washington DC - Woodhead Publishing Limited Cambridge England. pp. 307-333.

[5] HUANG, E.; MITTAL, G-S (1995): Meatball cooking - modeling and simulation. *Journal of Food Engineering*. (24) (1): 87-100.

[6] JARAMILLO-FLORES, M., E.; HERNANDEZ-SANCHEZ, H. (2000): Thermal diffusivity of soursop (*Annona muricata* L.) pulp. *Journal-of-Food-Engineering*. 2000. (46) (2): 139-143.

[7] KISS, B. *Növényolaj-ipari and háztartás-vegyipari táblázatok*. Mezőgazdasági Kiadó, Budapest. pp. 133-137.

[8] KÖRMENDY, I. (1991): *Műveletek hőközlandsel*. In Szenes E-né, Oláh, M. *Konzervipari Kézikönyv*. Integra Projekt Kiadó Budapest. pp.164-165.

[9] LARKIN, B.J., STEFFE, J.F. (1982): Error analysis of heat penetration data for determination of thermal diffusivity. *Journal of food Processing and Preservation*. (6) (1) 135-158.

[10] LARKIN, B. J., STEFFE, J.F. (1987): Experimental Errors associated with the estimation of thermal diffusivity from thermal process data. *Journal of Food Science*. (52) (2) 419-424, 428.

[11] LŐRINCZ, F., LENCSEPETI, J. (1973) *Húsipari Kézikönyv*. Mezőgazdasági Könyvkiadó, Budapest. p. 551.

[12] McDonald, K.; Da-Wen-Sun; Lyng, J-G (2002): Effect of vacuum cooling on the thermophysical properties of a cooked beef product. *Journal of Food Engineering*. 2002; 52(2): 167-176.

[13] MITRA, K., KUMAR, S., VEDAVARZ, A., MOALLEMI, M., K. (1995): Experimental evidence of hyperbolic heat conduction in processed meat. *Journal of Heat transfer. Transactions of the ASME* (117) (3) 568-573.

[14] MITTAL, G. S., BLAISDELL, J. L. (1984): Heat and Mass transfer properties of meat emulsions. *Lebensmittelwissenschaft und Technology*. (17) 94-98.

[15] RAJKÓ, R. (1994). Treatment of model error in calibration by robust and fuzzy procedures. *Analytical Letters*, (27) (1), 215-228.

[16] RIEDEL, L. (1969): Temperaturleitfähigkeitsmessungen an wasserreichen Lebensmitteln. *Kältetechnik und Klimatisierung*. (21) (11) 315-316.

[17] SANZ, P. D., ALONSO, M. D., MASCHERONI, R. H. (1987): Thermophysical Properties of Meat Products: General Bibliography and Experimental Values. *Transactions of the ASAE* (30) (1) 283-289, 296.

[18] SINGH, R.P. (1982): Thermal diffusivity in food processing. *Food Technology*. 36 (2) 87-91

[19] TEIXEIRA, A. A., DIXON, J. R., ZAHRADNIK, J. W., ZINSMEISTER, G. E. (1969): Computer optimization of nutrient retention in the thermal processing of conduction heated foods. *Food Technology* (23) (6) 845-850.

[20] TSCHUBIK, I. A., MASLOW, A. M. (1973): *Wärmephysikalische Konstanten von Lebensmitteln*. VEB Fachbuchverlag, Leipzig. p. 92

# GEOMETRIC AND AGRO-PHYSICAL CHARACTERISTICS OF WINTER WHEAT VARIETIES

E. Gyimes – A. Véha

Faculty of Food Engineering, University of Szeged

## Introduction and Literary Review

Investigations of agro-technical type are both foundational and synthesising in nature, which comprise agro-physics, the science of experimental agricultural mechanics. The objectives of investigations and the expected results are extremely important, therefore precision technologies in agriculture and crop processing require an even more precise planning as before. There is also a need for reconsidering theories, which should be done in view of all the changes in basic biology today. The changes the genetic pool of different wheat varieties and breeding trends have undergone is well illustrated by the fact that LELLEY back in 1967 wrote that small-grain varieties – being generally more vitreous – were of better baking quality. In 2000, however, Morgan et al. claimed that varieties with bigger kernel size had better, higher water absorbing capacity. A knowledge of kernel size is crucial in almost all operations from seed grain cleaning, sowing, harvesting to the making of the final product, including the precise control of post-harvest technologies. The outcome and technological efficiency of sifting before drying and grading before storage mainly depend on whether the size of the sift has been chosen properly, which can only be done if kernel size is known. In most technological processes the effect of size is fundamental. Knowing the right size is also of crucial importance in designing agricultural machines (POLYÁK, N.I., 2001). Kernels in the ears grow into different sizes. This sheer fact indicates in itself how important it is to know the sizes of the kernels and their distribution during post-harvest processing. Size is many times more important in seed production than in any other cases since only uniform seed grains can ensure optimal sowing and the even growth of seeds later (BOCKUS – SHROYER, 1996). In their studies GAN and STOBBE (1996) denied the necessity of separating small seeds. PICCINI et al (2001), among others, tested the effect of seed size on the incidence rate of various diseases but they did not find a significant correlation between size and disease. CSIZMAZIA et al (1994) carried out research into the size and other physical characteristics of wheat seeds and the regularities they show in their movement in the air. CSIZMAZIA et al (2000) developed a device for the measurement of floating speed, among other aerodynamic properties. In their novel ventilation shaft the floating speed of seeds can be measured more precisely than ever before, which makes it possible for the correlation between seed size and floating speed to be calculated far more accurately. The role of physical characteristics is crucial in the drying process. Besides size, size distribution, homogeneity, and mass density were also emphasized by BEKE (1997). Setting the right and most economical air flow speed requires the knowledge of mass kernel size, among others, if conveying and cleaning is done with the air-flow. RAHEMAN and JINDAL (2001), studying the vertical pneumatic conveying of agricultural grains, set up an empirical formula one component of which was mean kernel size. The significance of wheat kernel size in the milling process has been investigated by several researchers. CAMBELL and WEBB (2001) composed the function of milling and subsequently CAMPBELL et al (2001) went on to set up the equation of milling. One of the key elements of both publications is kernel size. A dynamically developing aspect of establishing kernel size is image analysis and artificial vision.

## Objective

Our main objective is to investigate the characteristics kernels of wheat for human consumption (*Triticum aestivum L.*) possess with regard to their geometry, morphology, hardness and agro-physics. Among the different elements of a system of

correlations, determining the geometric and morphologic qualities of wheat kernels was in the focus of our attention. We were mainly interested in learning about how the geometric characteristics of varieties grown widely in our days change and form in relation to their kernel size. A further question we aimed to answer was that of the extent to which growing conditions and the given year affect kernel size.

## Material, Methods and Means

The wheat samples used in our studies were provided by Szeged Cereal Research NPC (Szegedi Gabonatermesztési Kutató Kht). They were grown in small plots in the years 1999-2002. Samples were collected from different years, so the agro-meteorological conditions were substantially different. Table 1 contains the amount of fall measured in the experimental plots in Szeged.

Table 1 Amounts of wet measured in the experimental plots in Szeged

Years	Fall amount		
	Total	I-VI. months	IV-VI months
1971-2000	490,0	232,0	160,0
1998-1999	678,6	284,6	176,1
1999-2000	554,9	101,3	60,1
2000-2001	482,9	381,0	286,4
2001-2002	448,4	152,3	115,3

In 1999 the amount of precipitation was well above the average (almost 700 mm), which exceeds the average of many years by almost 60 %. This high total amount of precipitation explains why crop loss was not bigger and why quality was satisfying under droughty conditions in 2000. It is advisable to study fall largely if the values measured in the months of April – June are compared with the results of all four years tested.

All three measurements of 100 kernels were taken by means of a digital calliper. Resolution was 0,01 mm, precision 0,03 mm. A chart with the measured data was drawn up and the data assessed. At the beginning of our work we carried out control measurements and stated that the 100-100 measurement values we got represented our sample reliably, the repeatability and standard deviation of our measurement were within margin of error.

The proportions of geometric measures were described with the relation of measures and sphericalness. The sphericalness of wheat kernels is defined by the following formula (1) (SITKEI, 1981):

$$\text{sphericalness} = \frac{\sqrt[3]{WLTh}}{L} \quad (1)$$

where L: length, W: width, Th: thickness

This means that sphericalness derives from the proportion of the geometric mean value of the three measurements and that of the highest measurement value. Evidently, this value in the case of a sphere equals 1. Thus, the more spherical the body the closer its value to 1.

## Results

Of all the kernel sizes, width value can be taken as stable because – although there are deviations in different varieties – weather conditions (the amount of precipitation, first of all) did not affect it essentially. Contrary to this, length value decreased in dry years (2000 and 2002) causing the simultaneous increase of thickness value. The conjugate effects of these latter factors resulted in a significant rise of sphericalness values in years lacking enough wet.

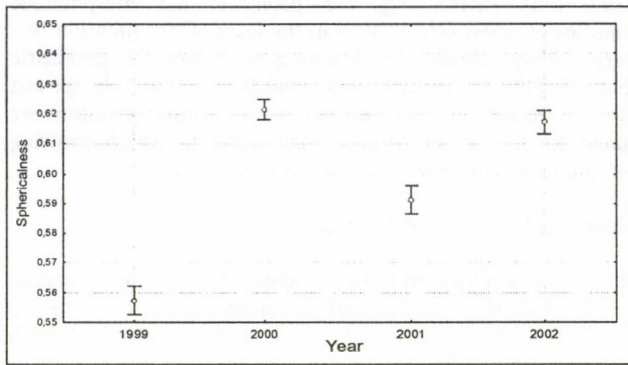

Fig. 1 Variations in sphericalness in 1999-2002

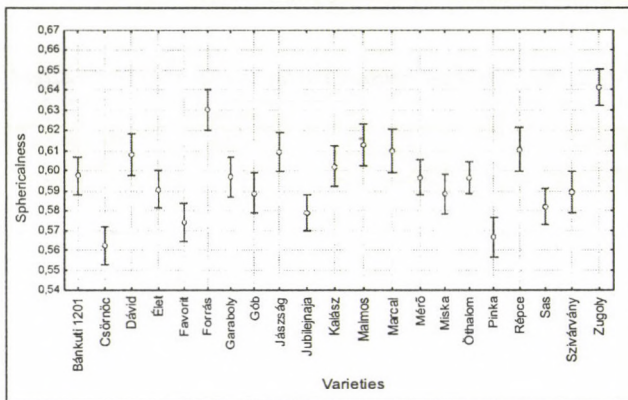

Fig. 2 Variations in the sphericalness of tested wheat varieties

Figure 2 suggests that sphericalness is also a variety-specific factor.

Hardness index (HI:%), that is the variations kernel hardness values show, is similar to sphericalness in that the inner firmness of kernels increases in dry years. (figure 3).

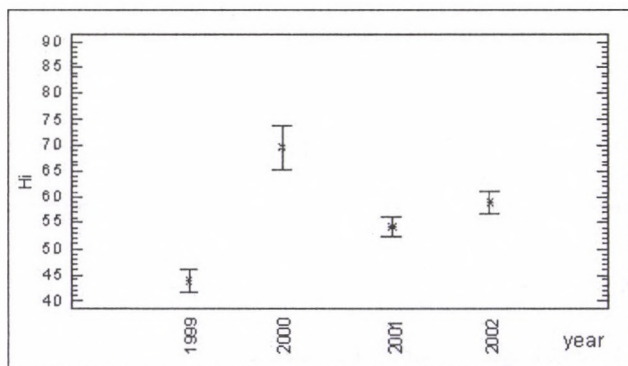

Fig. 3 Variations of mean hardness index values (HI:%) in different years

### Conclusions

Of all the kernel sizes, width value can be regarded as stable because – although there are deviations in different varieties –

weather conditions (and mainly the amount of fall) did not affect it essentially. Contrary to this, length value decreased in dry years (2000 and 2002) causing the simultaneous increase of thickness value. The conjugate effects of these latter factors resulted in a significant rise of sphericalness values in years lacking enough precipitation.

Our test results suggest that the theory of dry year = shrunken kernel seems to prove faulty.

Instead, kernels, in self-defence, tend to take up a spherical shape so that their specific surface be as small as possible.

The author and the research work was financed by János Bolyai Research Fellowship of HAS

### References

- [1] Beke, J. (1997): A szemes termények szárítása (in ed.Beke:Terményszárítás, Agroinform Budapest, pp9-419
- [2] Bockus, W. – Shroyer, J. (1996): Effect of seed size on seedling vigor and forage production of winter wheat. Canadian Journal of Plant Science, Vol. 76, No (1), p.101-105
- [3] Campbell, G. – Bunn, P. – Webb, C. – Hook, S. (2001): On predicting roller milling performance Part II. The breakage function. Powder Technology, Vol. 115, No (3), p.243-255
- [4] Campbell, G. – Webb, C. (2001): On predicting roller milling performance Part I: The breakage equation. Powder Technology, Vol. 115, No (3), p.234-242
- [5] Csizmazia Z. – Lajos, T. – Marschall, J. – Nagyné P.I.(2000): Új rendszerű légszatórna fejlesztése. Mezőgazdasági Technika, Vol. 41. No. 9., p. 2-5.
- [6] Csizmazia Z. – Nagyné. P. I. – Kasza F.(1994): The Determination of Physical Characteristics of Seeds for the Construction of Seeding Machines. Hungarian Agricultural Engineering, Vol. , No. 7.p. 63-66
- [7] Gan, Y. – Stobbe, E.(1996): Seedling vigor and grain yield of 'Roblin' wheat affected by seed size. Agronomy Journal Vol. 88, No (3), p.456-460
- [8] Lelley, J. (1967): A fajtakérdés és a magyar búzafajták. Mezőgazdasági Kiadó, Budapest p. 2-127
- [9] Morgan, B. – Dexter, C. – Preston, K. (2000): Relationship of kernel size to flour water absorption for Canada Western Red Spring wheat. Cereal Chemistry, Vol. 77. No. 3 p. 286-292
- [10] Piccinni, G. – Shriver, J. – Rush, C. (2001): Relationship among seed size, planting date, and common root rot in hard red winter wheat. Plant Disease, Vol. 85, No (9), p 973-976
- [11] Polyák, N.I (2001): Búzaszemek aerodinamikai jellemzői MTA-AMB 25. Kutatási és Fejlesztési Tanácskozás Gödöllő, Nr.25, Vol.1. pp 168-175.
- [12] Raheman, H. – Jindal, V. (2001): Solid velocity estimation in vertical pneumatic conveying of agricultural grains. Applied Engineering in Agriculture, Vol. 17. No. (2), p. 209-214
- [13] Sitkei, Gy. (1981): Mezőgazdasági anyagok mechanikája, Akadémiai Kiadó, Budapest p. 11-461

## EFFECT OF SAMPLE SHAPE AND SIZE ON MEASURED IMPEDANCE SPECTRUM

E. Vozáry – P. Mészáros

Budapest Corvinus University, Faculty of Food Science,  
Department of Physics and Control

### Introduction

Electrical impedance spectroscopy of the lower frequency ranges (10 Hz- 1 MHz) has been applied extensively in quality assessment of fruits and vegetables in our laboratory. The impedance spectroscopy is suitable to detect the irradiation of potato, too [1]. The resistance of intercellular part decreases in mechanical broken apple tissue in comparison to healthy tissue [2]. During drying of apple slices the increase of certain resistances can be described by special mathematical functions [3]. Up to the present the impedance spectra were measured between two gold plated copper electrodes punctured the investigated object, and the effect of shape and size of sample on the impedance spectrum was not considered. However, the relation of impedance spectrum to geometrical parameters of sample is necessary for determination of electrical conductivity and permittivity of biological tissue. The objective of this work was to determine the relation of measured impedance parameters with length of edges in parallelepiped samples cut out from apple and potato tissues.

### Materials and methods

Jonathan apples with 10-12 cm diameter and potato of 12-14 length and of 6-7 cm diameter were purchased at local market. The slices were cut out from the whole apple that the plane of *a* and *b* edges was parallel, and the *c* edge was perpendicular to the symmetrical axis of apple, respectively. The potato slices were cut out from the centre of potato tuber (Fig. 1.A). The length of *a*, *b* and *c* edges one by one could be 25, 20, 15, 10 and 5 mm for apple slices, and 60, 50, 40, 30, 20, and 10 mm for potato slices, respectively. Our slice technique allowed about 0.5-1 mm accuracy in edge lengths.

Impedance spectra were measured with the two-pin electrode arrangement shown in Figure 1.A. The diameter and the length of the gold-plated copper pins were 0.6 mm and 5 mm, respectively. The electrodes were connected to BNC jacks by copper wires and the BNC jacks were joined to the LCR meter by an electrically shielded 1 m length cable. Three different electrode distances, *d*, (2 mm, 5 mm and 10 mm) were used.

The magnitude,  $|Z|$ , and the phase angle,  $\varphi$ , of impedance were measured with an HP 4284A precision RLC meter in frequency range from 30 Hz till 1 MHz logarithmically divided into 45 frequency points. The voltage level of the sinusoidal signal was 1 V. The LCR meter was connected to a computer via a GPIB interface. Data collection was performed by a QBasic program.

An open- and short-circuit correction was applied to each measured spectrum to eliminate the impedance of sample holder and cables. The impedance of biological tissue and of electrode polarization was evaluated from corrected spectra measured with three electrode spaces in each single slice [4]. In this model calculation we assumed, that the electrode polarization is the same for each electrode and for each sticking in, and the biological tissue is homogeneous. Equipotential curves between two electrodes in sample with rectangle cross-section (Fig. 1.B) were calculated with MathLab program.

The electrical impedance, *Z*, can be represented by a complex number

$$Z = R + iX = |Z| \cos \varphi + i|Z| \sin \varphi, \quad (1)$$

where  $R = |Z| \cos \varphi$  and  $X = |Z| \sin \varphi$  are the real and the imaginary part of impedance,  $\varphi$  is the phase angle and *i* is the imaginary operator.

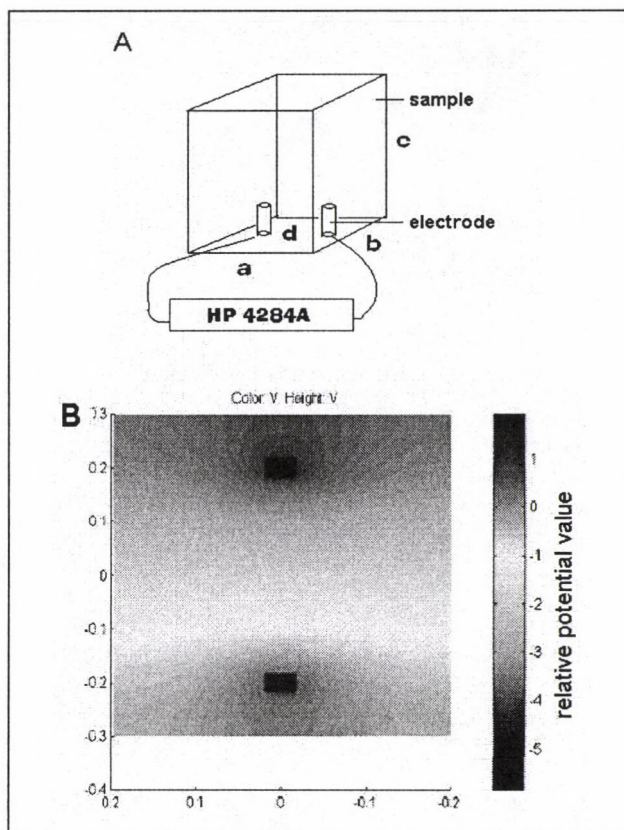

Fig. 1 A Electrode arrangement in apple and potato slices with *a*, *b* and *c* edges. *d* is the distances between the two electrodes.

B Figure Equipotential curves calculated with MathLab program between two electrodes in sample with rectangle cross-section.

### Results and discussion

A typical measured impedance magnitude and phase angle spectrum can be seen in Figure 2. The complex impedances can be calculated with equation (1) from the measured impedance magnitude and phase angle values and can be plotted on the complex plane. On this way constructed electrical impedance spectrum - called a Wessel or Argand diagram - is the distribution of impedance values in the frequency range of an applied alternating current [5]. On Figure 3. there are the measured with three electrode distances impedance spectra of one apple slices together with the calculated [4] tissue and electrode polarization impedance spectra. The electrode polarization is responsible for the low frequency part of impedance spectrum. The tissue impedance spectrum practically contained only one circular arc caused by the interface between extra and intra cellular part of apple flesh [6].

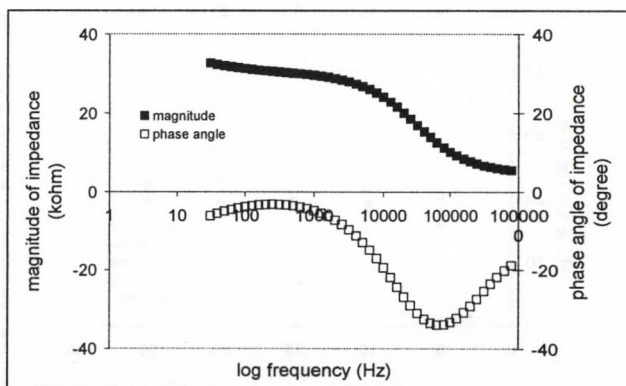

Fig 2 Typical measured impedance magnitude and phase angle spectrum

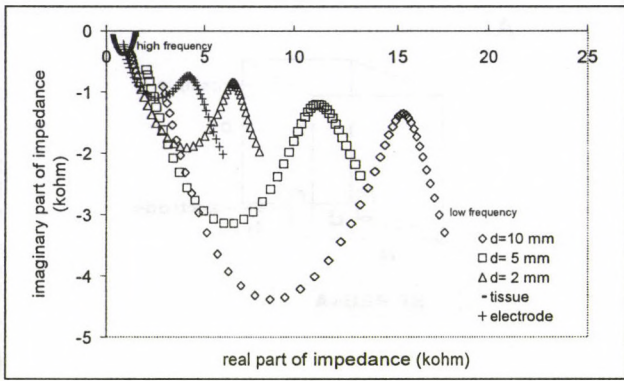

Fig. 3 Impedance spectra measured with three electrode distances in single apple slice and calculated impedance spectra of apple tissue and electrode polarization

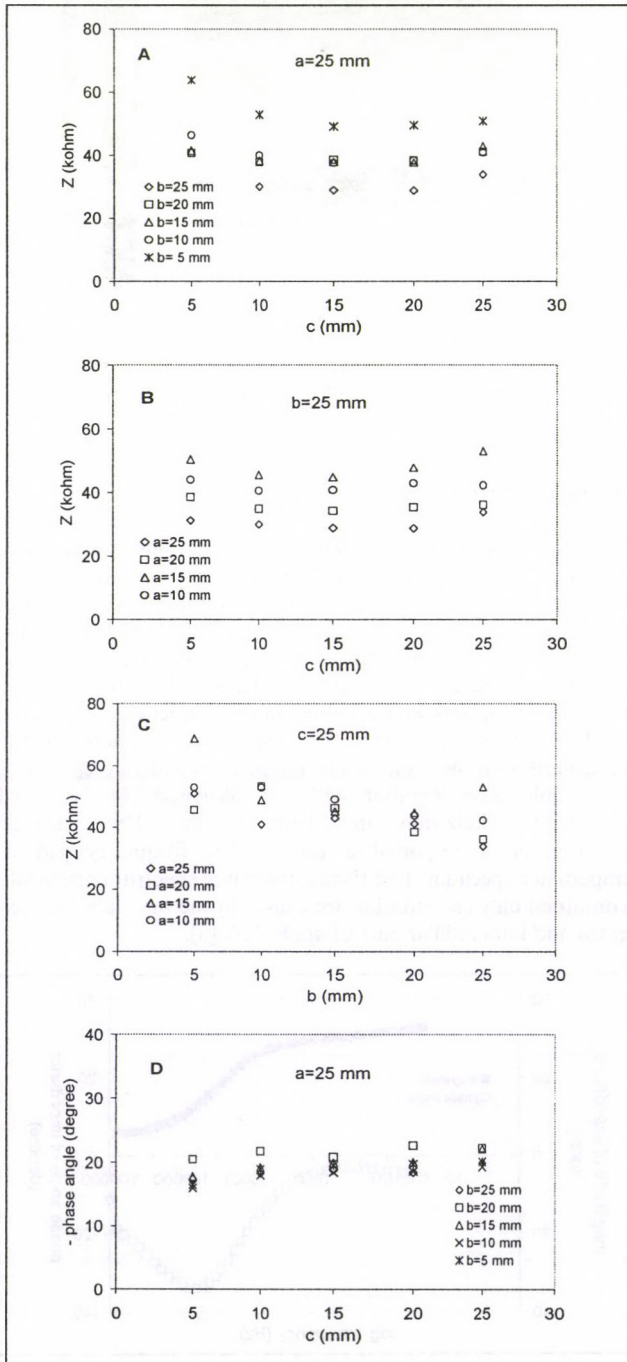

Fig. 4 Magnitude of impedance (A, B, C) and phase angle (D) at frequency of 1000 Hz in apple slices of various sizes

The phase angle of a given frequency remained almost constant in both apple and potato slices (Fig. 4.D and Fig. 5.B), if the size of slice changed. The unchanged phase angle refers to the homogeneity of tissue. Generally the magnitude of tissue impedance at 1000 Hz frequency increased (Fig. 4 A, B and C, and Fig. 5A) if the length of any edge decreased both for apple and potato slices. The tendency of this impedance increase was a little various depending on whether  $a$ ,  $b$  or  $c$  edge changed. Similar changes (not shown) of impedance magnitude could be observed at different frequencies in the whole investigated frequency range from 30 Hz till 1 MHz.

Difference in change of impedance magnitude at low (100 and 1000 Hz) frequency in comparison to change at higher frequencies (above 1000 Hz) for potato slices (Fig. 5A) can be explained by that, the impedance spectrum of potato tissue contains two circular arcs [3], and the capacitive character of these two arcs differ from each.

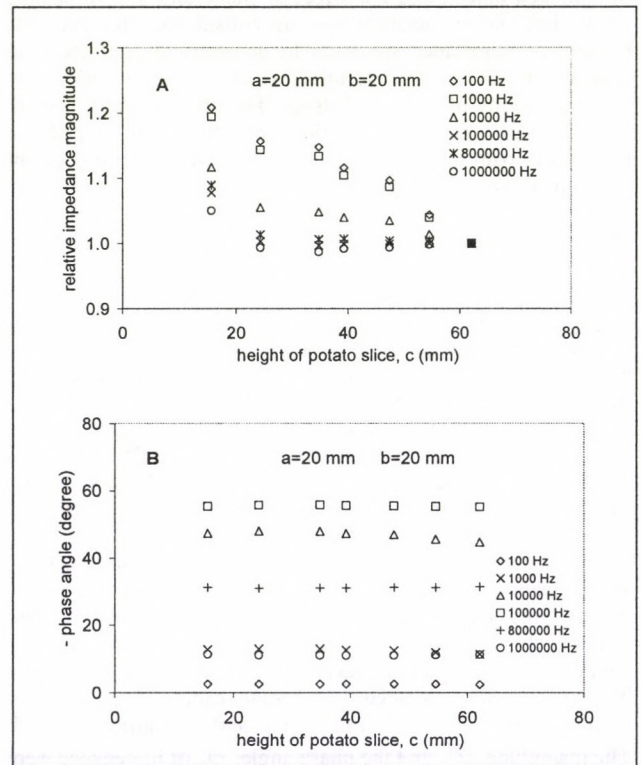

Fig 5 Magnitude (A) and phase angle (B) of impedance at various frequencies from 100 Hz till 1 MHz in potato slices of decreasing height

The magnitude of impedance decreases if the length of current paths in the sample decreases or the cross-section between the two electrodes increases. In Figure 1.A and 1.B it can be seen if the length of any edge from  $a$ ,  $b$  and  $c$  is reduced, that pathways of current are modified and altogether the current paths becomes slightly shorter. Reducing the length of both  $b$  and  $c$  edges results the decrease of cross-section. The shorter current paths decrease the impedance magnitude and the diminished cross-section increases the impedance magnitude. These two contradicting effects can explain that the decreasing tendency of impedance at low  $b$  and  $c$  values is followed by a slight increasing tendency (Fig.4 A, B, C and Fig. 5 A) in the range of higher  $b$  and  $c$  values.

### Conclusion

The magnitude of impedance depends and the phase angle does not depend on the size of sample under measurement. The length of current paths and the cross-section of sample

determine the impedance magnitude. Repeating the impedance measurement on samples with more accuracy edge lengths and with more  $a$ ,  $b$  and  $c$  values it can be possible to determine the mathematical function between the geometrical factors (length of edges) of sample and the impedance magnitude. There is purposed in the future to give a theoretical evidence of our experimental results by evaluation of impedance between two pins with finite element method by ANSYS program.

#### Acknowledgment

This work was supported by the Hungarian Research Fund (OTKA, grants T 042911).

#### References

[1] Felföldi, J., László, P., Barabássy, S. and Farkas, J. (1993) "Dielectric method for detection of irradiation treatment of potatoes", *Radiation Physics and Chemistry*, Vol. **41**, 471-480.

[2] Vozáry, E., László, P. and Zsivánovits, G. (1999) "Impedance Parameter Characterizing Apple Bruise", *Annale of New York Academy of Science* Vol. **873**, 421-429.

[3] Mészáros P., Vozáry E., Funk D., (2004) "Electrical Impedance of Apple Slices during Drying", *Proceeding of the 12th International Conference on Electrical Bioimpedance and 5th Electrical Impedance Tomography*, pp.61-64., Gdansk, Poland

[4] Vozáry E., László P., Sass P. (1997) "Almaszövetek impedancia paraméterei" *Gyümölcs-Zöldség Postharvest és Logisztikai Konferencia Kiadványa*, Budapest. KÉE közl. vol. 54. pp- 91-96.

[5] Grimnes, S. and Martinsen, O.G. (2000) *Bioimpedance and Bioelectricity*, Basics, Academic Press, New York

[6] Martinsen, O.G., Grimnes, S. and Schwan, H.P. (2002) "Interface Phenomena and Dielectric Properties of Biological Tissue", *Encyclopedia of Surface and Colloid Science*, Marcel Dekker, Inc. pp. 2643-2652.

## DRYING CHARACTERISTICS OF DIFFERENT VEGETABLES

K. Kacz K. – A.J. Kovács – Zs. Stépán Zs. – M. Neményi  
University of West Hungary, Faculty of Agricultural and Food Sciences, Institute for Biosystems Engineering, Mosonmagyaróvár

### Introduction

Examinations of different drying characteristics of vegetables have been carried out for the last four years at the Biosystems's Engineering Institute. The thin layer drying experiments have been financed by the Hungarian NKFP project (No. 4/030/2001). The aim of the research was to model the work of belt dryers used in practice.

By evaluating the thin layer drying experiments several heat physical parameters can be determined. Thus, the drying curves can be calculated and the integral moisture content can be determined at any time of the drying (Kacz et al., 2004). It is necessary to know the moisture gradients as driving forces in order to model the heat and mass transfer processes. For this the equilibrium moisture contents have to be known. At the same time our goal was to use water potential gradients instead of moisture gradients during the modeling of mass transport processes. Therefore, sorption experiments of carrots were carried out.

### Materials and Methods

The measurements were carried out at the Food Technological laboratory of the Institute on the following vegetables: root cubes, slices and stripes of carrot and parsley, onion and tomato (slices), green pepper (stripe), parsley and dill.

The thin layer drying experiments were carried out using a computer controlled convective drying tunnel. The measurements probes and data logger device were ALMEMO type equipment. The measured parameters were recorded with a frequency of 15 seconds. A Precisa 505 M-2020 C analytical balance was used to follow the weight changes, the surface temperature of the drying material was measured by an AMIR FI 628-5 type infrared temperature meter.

The integral moisture content values of the one- and two-stage drying experiments; the drying- and moisture rate curves were compiled. Thus the drying equations could have been determined.

The integral moisture contents, the drying and moisture ratio curves were calculated from the one and two stage experiments. Thus the drying equations could have been determined.

There were contradicts in the literature concerning sorption isotherms (H.A. Iglesias – J. Chirife, 1982) of carrots in different temperatures. However they reported lower moisture content and max. 80% relative humidity. Therefore, detailed sorption isotherm measurements were carried out using a given carrot. For these a ROTRONIC HygroLab 3 type water activity meter was used for 24 and 60 °C temperatures with two repetitions. For comparison drying chamber measurements were conducted for 24 and 32.8 °C.

The water potential ( $\Psi$ ) can be determined from the sorption isotherms as follows:

$$[\Psi]_x = -\frac{R_U \tau}{m_v} \cdot \ln \phi \quad (1)$$

Where:  $\phi$  is the relative humidity of the air (decimal);  $R_U$  is the universal gas constant;  $\tau$  is the temperature;  $m_v$  is the molecular weight of vapor. Knowing the sorption isotherms the  $\Psi = \Psi(\tau, X)$  function can be determined for all the examined materials.

Naturally, the moisture gradient based transport equations have to be modified so that the driving force will be the water potential (M. Neményi – A. Kovács, 2003) The moisture gradient based mass transfer equation:

$$\frac{\partial X}{\partial t} = D \left( \frac{\partial^2 X}{\partial x^2} + \frac{\partial^2 X}{\partial y^2} \right) \quad (2)$$

The water potential based mass transfer equation:

$$\frac{\partial X}{\partial \Psi} \frac{\partial \Psi}{\partial \tau} = \frac{\partial}{\partial x} \left[ D \frac{\partial X}{\partial \Psi} \cdot \frac{\partial \Psi}{\partial x} \right] + \frac{\partial}{\partial y} \left[ D \frac{\partial X}{\partial \Psi} \cdot \frac{\partial \Psi}{\partial y} \right] + \frac{\partial}{\partial z} \left[ D \frac{\partial X}{\partial \Psi} \cdot \frac{\partial \Psi}{\partial z} \right] \quad (3)$$

Using this solution the coupled heat and mass transfer in inhomogeneous materials can be more accurately and physically more correctly described (Neményi, 2001).

Based on Prof. Sitkei's suggestions the pF values of carrot have been determined. (The water holding capacity of soils can be expressed with the negative capillary pressure that is:  $\Delta p = h \cdot g$ . The pF is the 10<sup>th</sup> logarithms of this pressure expressed in cm). The pF values can be directly calculated from the water potentials.

### Results

By the thin layer experiments we were focusing on carrots. Fresh and differently stored samples were tested with one- and two-stage drying experiments and combined treatments (convective + microwave). Fig. 1. shows an example of two-stage carrot drying experiment with two repetitions. The least drying time corresponds to cubes and the highest applies to the slices. The highest drying rate was detected on the fresh samples. The moisture loss rate significantly decreased after a short (1-2 weeks) period of storage. One-stage experiments were carried out with two drying parameter sets (100 °C, 0.5 m/s; 80 °C, 0.3 m/s). The moisture ratios (MR) can be seen on Fig. 2.

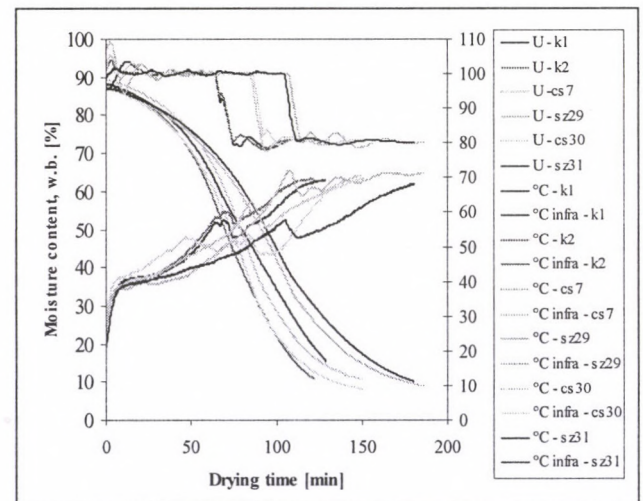

Fig. 1 Two-stage drying experiments of carrot

The equations of drying curves were determined from the fitting of MR curves. The most accurate solution of both the one- and two-stage experiments was the following:

$$\ln MR = a + b \cdot T^c$$

Where:

$MR = \frac{(X - X_e)}{(X_0 - X_e)}$ ;  $T$  is the drying time;  $a$ ,  $b$  and  $c$  are constants.

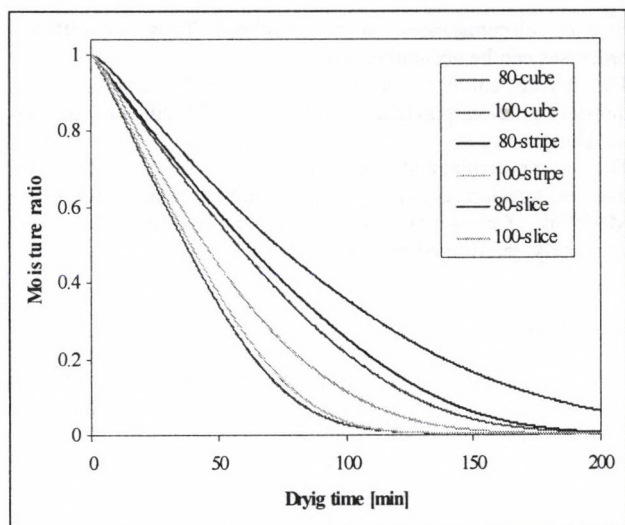

Fig 2 Moisture ratio (MR) curves of one stage drying experiments of carrot

In general the most accurate results can be found when the exponent is 1.5 of the first part of the two-stage experiments and one-stage experiments and 1 of the second part of the two-stage experiments and parsley. Fig. 3. shows the equation fitting of the two-stage technology of carrot slices.

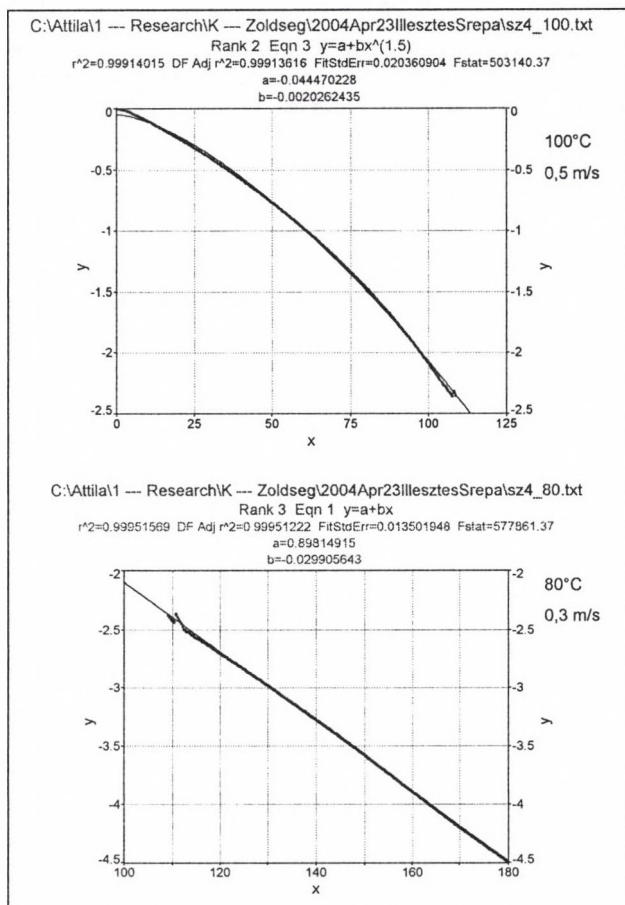

Fig. 3 Determination of MR functions of two-stage experiments of carrot. (X is the drying time in min.; Y corresponds to the lnMR.)

Fig. 4 shows (also as an example) the measured and calculated MR values of the differently prepared carrots. There were minimal differences between the measured and calculated values for all the three cases. The moisture loss rate was the same at the carrot cubes and slices.

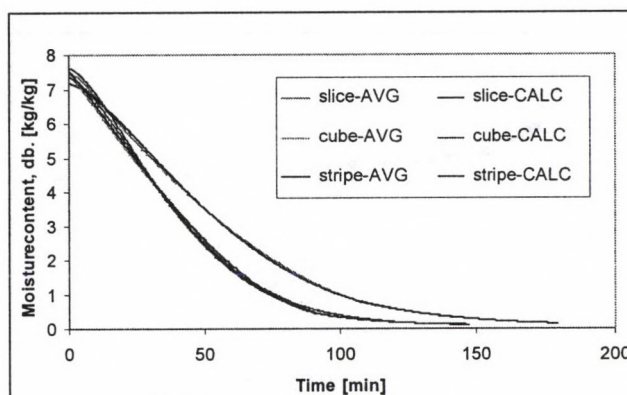

Fig. 4 The measured and calculated moisture content values of the two-stage drying of carrots

Fig. 5 shows the results of the water activity meters and water potential experiments. The desorption isotherms based on equilibrium moisture content at 20 °C was (Fig. 6.). Based on this the Y(T,X) and pF(T,X) functions were determined. Figure 7. shows the calculated and measured water potential and pF values respectively.

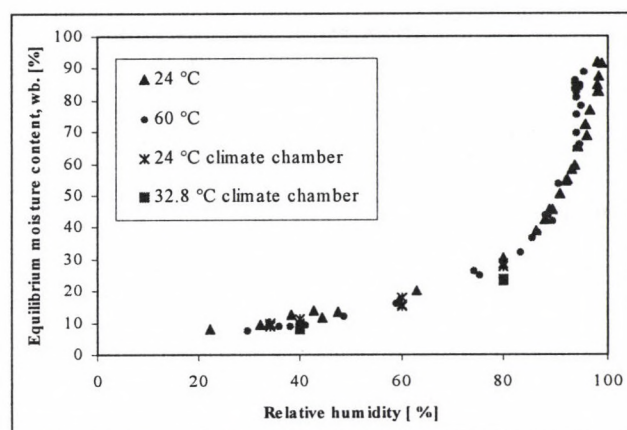

Fig. 5 Equilibrium moisture content curves of carrots measured with different temperatures and methods (water activity meter and climate chamber method)

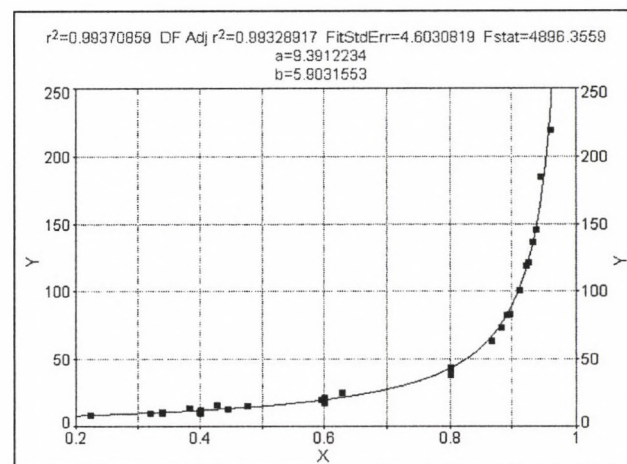

Fig. 6 Determination of desorption equation of carrot (24 °C)

$$X = a \left[ \frac{\varphi}{1 - \varphi} \right] + b;$$

$$\varphi = \frac{X - b}{X + a - b}$$

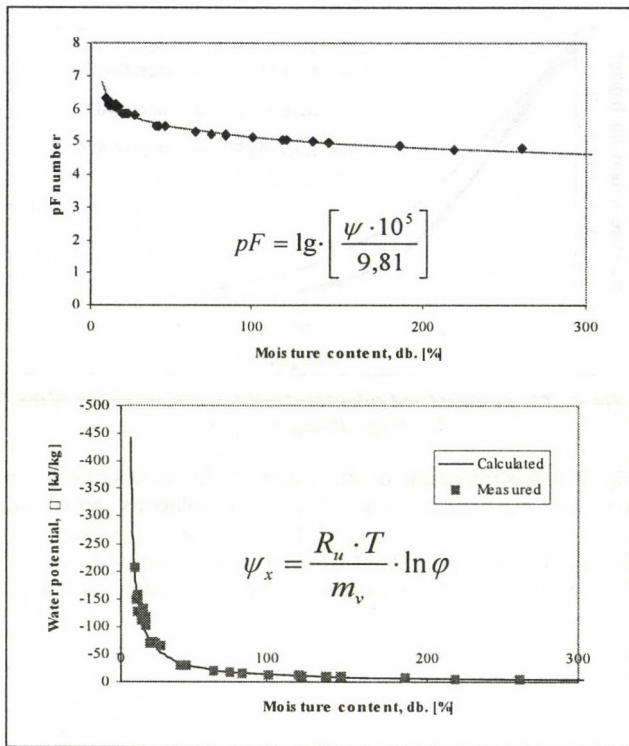

Fig. 7 Calculated and measured water potential and pF values as a function of moisture content at 24 °C

**Conclusions**

The results of the thin layer drying experiments can be well adapted to the operation and planning of belt driers. The

practical circumstances can be simulated. Thus, the different processes can be accurately tested.

The drying curve equations can be use for description of moisture gradient potential as driving force based heat and mass transfer processes.

The water potential and so called pF values could be determined over the sorption region and higher than 80% relative humidity. Modeling of mass transport processes can be easier and more accurately determined by using the water potential equations.

**Literatures**

[1] H. A. Iglesias – J. Chirife (1982): Handbook of food isotherms: water sorption parameters for food and food components. Academic Press, New York.  
 [2] Kacz K. – Kovács A. J. – Stépán Zs. – Neményi M. (2004): Sárgarépa szárítástechnikai tulajdonságainak vizsgálata kismin-ta-kísérletekkel. (Drying experiments of carrots) VI. Nemzet-közi Élelmiszertudományi Konferencia. (6<sup>th</sup> International Con-ference of Food Sciences), Szeged, Hungary, 20-21. May. ISBN 963 482 6776.  
 [3] Neményi M. (2001): A biológiai (anizotrop) anyagokban lejátszódó hő- és anyagtranszportok modellezése Gibbs-tól napjainkig - Javaslat egy új modellezési eljárásra. (Modeling of heat and mass transfer processes in biological materials...) 4. Magyar Szárítási Szimpózium, (4<sup>th</sup> Hungarian Drying Symposium) Mosonmagyaróvár, Hungary, 18-19. Oct. CD-ROM. ISBN 963 9364 35 5.  
 [4] Neményi M.; Kovács A. J. (2003): Vízkötési potenciálra alapozott hő- és anyagtranszport modellek biológiai anyagok-ban. (Water potential based heat and mass transfer processes in biological materials) 5. Magyar Szárítási Szimpózium, (5<sup>th</sup> Hun-garian Drying Symposium), Szeged, Hungary, 21-22. Oct. CD-ROM, ISBN 963 482 647 4.

## DYNAMIC AND STATIC METHODS OF KERNEL HARDNESS MEASUREMENT

A. Véha – E. Gyimes – B. Szabó P.  
Faculty of Food Industry, University of Szeged

### Introduction

One of the most important specific characteristics of wheat verticum, indicative of both quality and end-use is kernel hardness.

In our country wheat producers can choose from up to 200 varieties. These are classified as hard or vitreous and soft or floury.

A comparison of different methods for determining kernel hardness provides help to all participants of the product cycle – from wheat breeders to flour processors - with choosing the right varieties.

### Literature review

Kernel hardness is one of the most important characteristics, which has long been in the focus of researchers' attention. By kernel hardness we mean both physical hardness and the energy consumption in grinding. This energy demand is a crucial physical indicator of wheat quality. Wheat hardness affects the milling process and it also determines the properties, quality parameters and the usability of the milling product. Furthermore, it determines conditioning parameters, flour yield, starch damage and water absorbing capacity. Kernel hardness itself is an inherited feature of wheat varieties and depends on the relation between starch granules and protein matrix. The degree of adhesion is regulated by a protein called friabilin present in high concentrations in soft genotypes and low concentrations in hard ones, and is a marker for softness, that is (Békés, 2001). Thus adhesion is weaker in soft and stronger in hard wheat varieties. It should be noted, however, that hardness and vitreousness are not entirely the same. (Hardness is a genetic while vitreousness is an agronomic feature.) Hardness, to a lesser extent, can be also affected by other factors like weather, site, moisture content, temperature, protein content, grain shape, grain size (Ács et al., 2003). Until recently kernel hardness was inferred from vitreousness in Hungary.

The indicators of hard wheat varieties surpass those of soft ones in several ways. Such indicators are flour yield and flour particle size since the adhesion between the starch granules and proteins of hard varieties is so strong in the milling process that starch granules fragment rather than get released from the protein matrix (as they do in soft varieties). The starch gets damaged, which then affects the water absorbing capacity of the flour (thus improving both its water absorbing and gas-retaining capacities).

It is not only kernel hardness that affects the qualities of the flour gained from a particular wheat variety but also other factors like using herbicides for weed control in wheat (Tanács et al, 2004). Due to these essential parameters the breeding of hard wheat varieties has gained real importance, the flour from hard varieties being the most suitable for use in the baking industry, in the making of bread and other bakery products. Sitkei (1981) applied a static method to investigate wheat grains in detail while Bölöni (1996) and Véha-Gyimes (1999) conducted measurements using a dynamic method.

### Objectives

Our objectives are to determine and assess the reactions of wheat kernel texture to mechanical force on the one hand, and to find out and draw conclusions about the inner texture of agricultural materials on the other hand. To reach these goals we described and compared two dynamic methods (SKCS 4100

measuring device and Perten 3303 disk-type mill) and a static method (LLOYD 1000 R testing machine) to measure kernel hardness.

### Measurement Method and Materials

We tested GK-Mérő, a soft endosperm wheat variety and Jubilejnaja-50, a hard one. We investigated samples harvested in the years 2000 and 2003.

The Perten SKCS 4100 measuring device can test 300 kernels in 3 minutes on the average and report the following data: kernel hardness, kernel size (diameter), moisture content and thousand kernel weight. Grinding resistance was measured by means of the Perten 3303 disk-type mill and the following formula applied (Bölöni, 1996):

$$e_r = \frac{e_{dt}}{\Delta a_d} \left[ \frac{\text{mWh}}{\text{cm}^2} \right]$$

$e_{dt}$  = specific grinding energy demand ( kWh/t)

$\Delta a_d$  = specific grits surface increase (  $\text{cm}^2/\text{g}$ )

$\Delta a_d = a_d - a_{d0}$

$a_d$  = specific surface of milling product

$a_{d0}$  = specific surface of grain crop before grinding

After smoothing the surface on the side of the beard and the germ we press the kernels with the compressor head of a LLOYD 1000R testing machine of 5000 N capacity, and by reading the force-deflection curve we measure the crushing force. Assessment was carried out from data saved on computer.

### Results and Assessment

Figure 1 shows the compression curves of two wheat varieties as recorded by the LLOYD 1000 R testing machine.

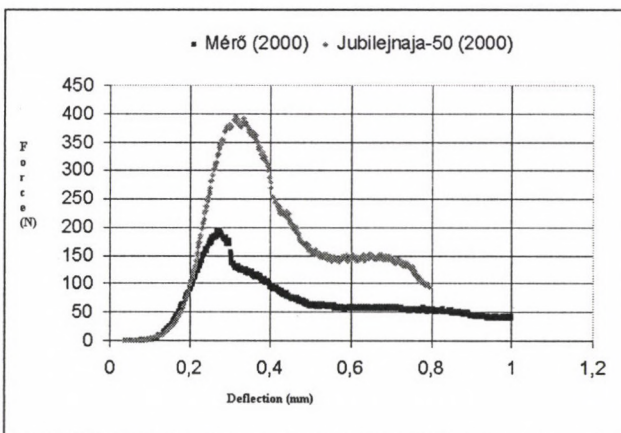

Fig. 1 Force-deflection curve in testing wheat kernel compression

Table 1 is a summary of results.

Table 1 Summary of dynamic and static measurement results

Variety (year)	SKCS 4100 (HI, %)	Grinding resistance ( $e_r$ mWh/cm <sup>2</sup> )	LLOYD 1000 R		Hardness grade
			Crushing force (N)	Steepness (N/mm)	
GK-Mérő (2000)	30,04	25,48	203,32	1688	Soft
Jubilejnaja-50 (2000)	68,89	43,776	409,69	3855	Hard
GK-Mérő (2003)	20,88	26,49	127,02	873,83	Soft
Jubilejnaja-50 (2003)	80,44	51,21	325,1	2160	Hard

**Limits:**

- Perten SKCS 4100: soft wheat kernel <50<hard wheat kernel
- Grinding resistance: soft wheat kernel<35<hard wheat kernel
- LLOYD 1000 R:  
 crushing force: soft wheat kernel<250<hard wheat kernel  
 steepness: soft wheat kernel<2000<hard wheat kernel

Dynamic methods provide quick data collection. Dynamic methods model processing operations (the importance of specific grinding energy use in practice).

The results of the static measurement of kernel hardness provide new information in learning about the qualities of visco-elastic materials of agricultural origin.

Compared to the dynamic method testing grinding energy, the static method is more sensitive in revealing the effect of the year equally hard wheat varieties were harvested in.

Wheat kernel testing methods need improving, refining and specifying. They are an important field of research into wheat-verticum.

The number of test materials (wheat varieties) should be increased.

The introduction of another comparison made with methods suitable for establishing the agro-physical and bio-chemical

qualities of wheat would offer a new opportunity to assess the quality of wheat varieties in a complex way.

**References**

[1] Ács P. – Matuz J. – Gyuris K. (2003): Aestivum búzafajták szemkeménységének változása az évjárat és a termőhely hatására, IX. Növénytermesztési Tudományos Napok, Magyar Tudományos Akadémia, Budapest p. 70

[2] Békés, F. (2001): A búza endospermium szerkezetének szerepe néhány minőségi búzát termelő országban. (in szerk Bedő, Z. : A jó minőségű, keményszemű búza nemesítése és termesztése, p. 25-34)

[3] Bölöni, I. (1996) : A takarmányaprítás új, két-változós energetikai összefüggése. Járűvek, Építőipari- és Mezőgazdasági Gépek, Vol. 43., No 3, p. 108-110

[4] Sitkei, Gy. (1981): Mezőgazdasági anyagok mechanikája, Akadémiai Kiadó, Budapest p. 11-461

[5] Tanács L. – Gerő L. – Soós J. – Petrőczy M. (2004): Gyomirtószeres állománykezelések és az évjárat hatása búzafajták szemterméséből készített lisztek sűtőipari és reológiai tulajdonságaira, Növénytermesztés, 53. No. 1. p 43-60

[6] Véha, A – Gyimes, E. (2000): Determining Kernel Hardness Through the Granulometric Parameters of Grinding. Hungarian Agricultural Engeneering, Gödöllő Vol. 13, p. 29-31.



Year	Grinding Energy (kJ/kg)	Kernel Hardness (Perten SKCS 4100)
2001	10	45
2002	15	50
2003	20	55
2004	25	60
2005	30	65

# OPTIMAL FREQUENCIES OF INERTIA TYPE FRUIT TREE SHAKERS

(Sponsored by the Hungarian Scientific Research Fund)  
Láng Z.  
Technical Department, Corvinus University, Budapest

Optimal shaking frequency can be defined in many ways. In this paper optimal shaking frequency means shaking the tree at one of its natural frequencies, whereby the efficiency of the power input is the highest.

## Theoretical background

### Natural frequency of a damped swinging system of one degree of freedom

If the damping is proportional to the speed of motion, the differential equation of the oscillation is

$$m\ddot{y} + k\dot{y} + \frac{y}{c} = 0, \text{ or } \ddot{y} + \frac{k\dot{y}}{m} + \alpha^2 y = 0 \quad (1)$$

$$\text{Where } \alpha = \frac{1}{\sqrt{mc}} \quad (2)$$

Pre-stressing the spring by  $y_1$ , the instantaneous displacement of the mass  $m$  will be (Fig. 1):

$$y = y_1 e^{-\frac{k}{2m}t} \cos \gamma \cdot t \quad (3)$$

where:

$$\gamma = \sqrt{\alpha^2 - \left(\frac{k}{2m}\right)^2} \text{ is the angular velocity of the system.} \quad (4)$$

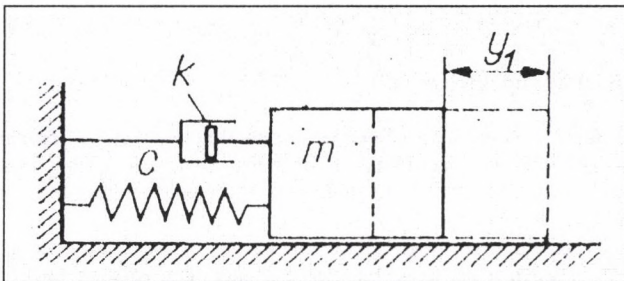

Fig. 1 Model of a damped oscillating system of one-degree-of-freedom

If the damping reaches its crucial value there is no swinging. In this case  $\gamma=0$  and

$$k_{cruc} = 2m\alpha$$

$$\text{or: } k_{krit} = 2\sqrt{\frac{m}{c}} \quad (5)$$

The relation of the actual and the crucial damping is called the *Lehr* damping, which is:

$$D = \frac{k}{k_{krit}} \quad (6)$$

The  $k$  coefficient of viscous damping can be defined of the amplitude-time curve of the free swinging (Figure 2):

$$k = \frac{2m\Lambda}{T} \quad (7)$$

where  $\Lambda$  is the logarithmic decrement:

$$\Lambda = \ln \frac{y_n}{y_{n+2}} \quad (8)$$

and  $T = 2\pi / \gamma$  is the time of a period.

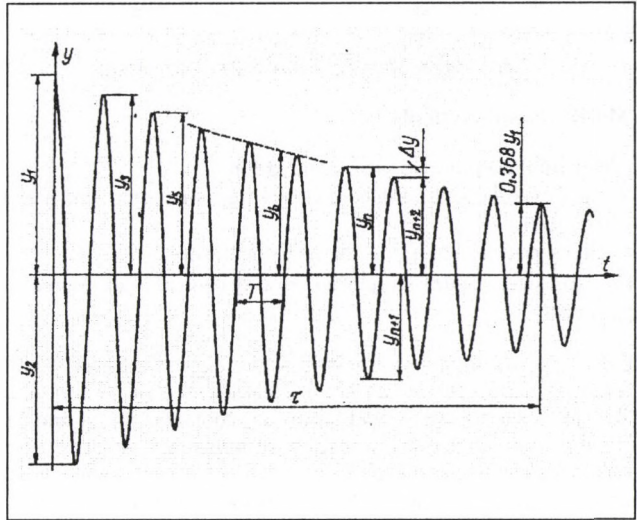

Fig. 2 The amplitude-time curve of the damped swinging

At forced vibration with rotating unbalanced masses the differential equation of the oscillation is:

$$m\ddot{y} + k\dot{y} + \frac{y}{c} = m_{unb} r \omega^2 \sin \omega t \quad (9)$$

And the amplitude of it is

$$Y = \frac{m_{unb} r \omega^2}{\sqrt{\left(\frac{1}{c} - (m + m_{unb})\omega^2\right)^2 + (k\omega)^2}} \quad (10)$$

According *Rayleigh* the oscillating mass  $m$  of a one freedom system can be calculated if the natural frequency of the system is defined without and with an extra mass  $m_e$  attached to  $m$ :

$$m = \frac{m_e}{\left(\frac{f_1}{f_2}\right)^2 - 1} \quad (11)$$

### Transversal oscillation of uniform beams

For clamped beams of uniform cross section the natural frequencies belonging to the most important mode shapes (Fig. 3) can be calculated as follows (Broch, J.T. 1980):

$$\alpha = \frac{A}{2 \cdot \pi \cdot l^2} \sqrt{\frac{I \cdot E}{\rho \cdot S}} \quad (12)$$

where

$A$  = coefficient from Figure 3

$l$  = length of beam

$I$  = area moment of inertia of beam of uniform cross section

$E$  = Young's modulus

$\rho$  = mass density of beam material

$S$  = area of cross-section

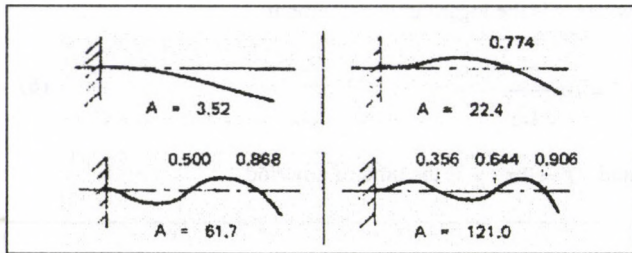

Fig. 3 Mode-shapes for clamped uniform beam

### Materials and methods

The natural frequencies were defined for

- The finite element models of cherry trees of central leader and vase form
- Cherry trees of central leader and vase form
- A fruit-tree model simplified to a system of one degree of freedom

Finite element model of a central leader and a vase type cherry tree was built of trunk, straight primary and secondary limbs, as well as straight primary and secondary roots. (Figure 4 and 5). To be able to compare the two structures most of the characteristics were chosen to be equal. Both were symmetrical around their central axis. Both structures consisted of app. 10 cm long cylindrical elements. The diameter of the cylinders changed so that at any height the diameter of the elements in the two models was the same. The total height was 2.21 m, their total mass 102.5 kg at a density of 1000kg/m<sup>3</sup>. Young's modulus was uniform for the two model but it decreased with the height. The Poisson's constant was set to 3.57 for each element (Fig. 6) (Láng and Csorba, 2004).

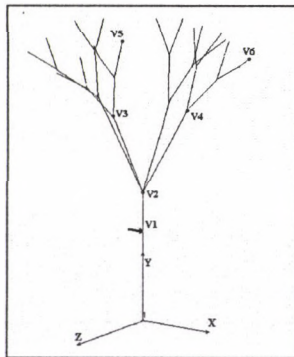

Fig. 4 Vase type tree model

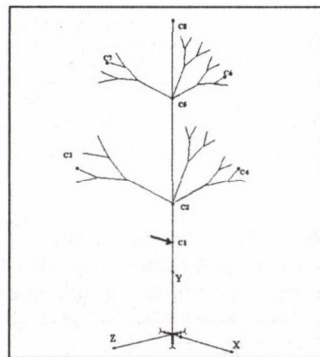

Fig. 5 Central leader type tree model

The two finite element models were virtually exposed to the effect of steady-state horizontal forced vibration of the following form:

$$F_g = m \cdot r \cdot (2 \cdot \pi \cdot f)^2 \cdot \cos(2 \cdot \pi \cdot f \cdot t) \quad (13)$$

Were

$m$  and  $r$  are the mass and eccentricity of a virtual inertia type shaker,

$0 < f < 20$  Hz was the chosen frequency range.

To get comparable results to real values, field experiments were carried out on central leader and vase type cherry trees after harvest (no fruit on the trees). The geometrical sizes of the samples were similar to those of the models. Accelerometers were fixed on different parts of the trees. The stems were quickly pre-stressed by a force of approximately 3000 N and released. The acceleration versus time curves were processed using FFT method to determine the natural frequencies of the examined parts.

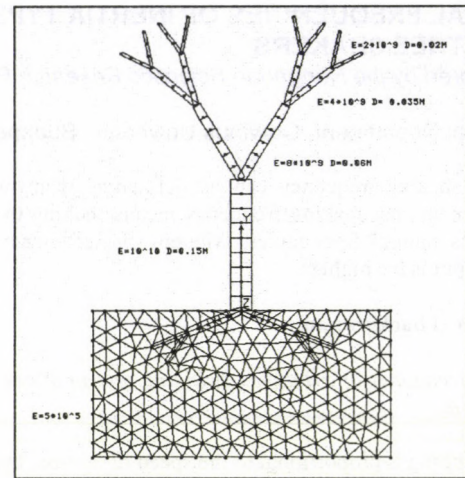

Fig. 6 The construction of the finite element models

The acceleration of trunk, primary and secondary limb at different shaking frequencies was recorded in field experiments using an inertia type shaker. The evaluated data gave the acceleration/frequency curves of measured parts of the tree.

The fruit-tree model simplified to a one degree of freedom system was composed of mass, spring and damping element, as in Figure 1.

The model parameters were measured as follows:

- the apparent spring constant was established by pre-stressing the trunk and by recording the force and displacement
- the reduced limb mass was calculated using Rayleigh's method (Eqn 11). The extra mass, fixed to the trunk at 80 cm height was 13.5 kg. Using FFT, from the acceleration versus time curves the frequency spectra was set up.
- the viscous damping coefficient was calculated from the acceleration versus time curves of the free oscillating trunk, using Eqn 7 and 8.

### Results and discussions

Figure 7 shows the acceleration versus frequency curves drawn of the field measurement data. Note that the acceleration values do not increase when the frequency of shaking reaches the 10-12 Hz value.

The acceleration versus frequency curves of the finite element tree model, using a virtual inertia shaker with rotating masses (Eqn 14) are shown in Figure 8.

Although the curves for the real cherry tree and the tree model (Figure 7 and 8) are not totally the same, their tendency is similar. The dissimilarity may be explained by the differences in geometrical size, shape, structure, total mass and mass-distribution.

Natural frequencies of a vase type cherry tree model, calculated using FFT are shown in Table 1. The frequency values from F1 to F8 are quite similar.

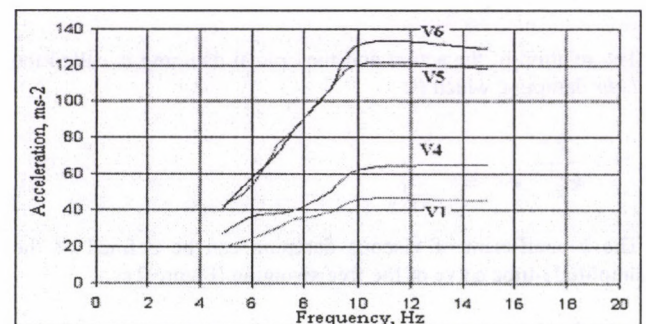

Fig. 7 Acceleration versus frequency curves for a vase form cherry tree

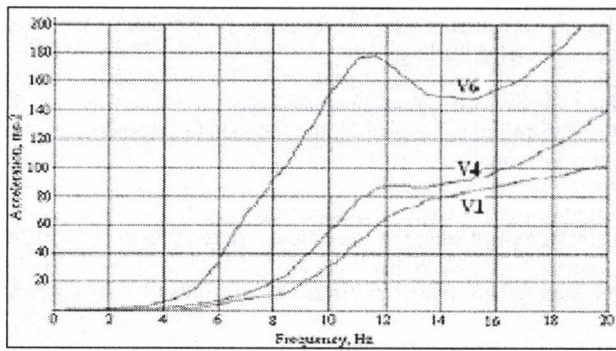

Fig. 8 Acceleration versus frequency curves for the vase type model, shaken virtually

Table 1 Natural frequencies of different nodes on the vase type tree model, Hz

Node on the model	F1	F2	F3	F4	F5	F6	F7	F8
V1	1,56	3,91	9,37		12,5	15,62		
V2	1,56	3,91	8,59	10,15	13,3		17,68	
V3	1,56	3,91	8,59	10,94		15,62		18,75
V4	1,56	3,91	8,59	10,94		15,62	17,18	18,75
V5	1,56	3,91	8,59	10,94	13,2	15,62		

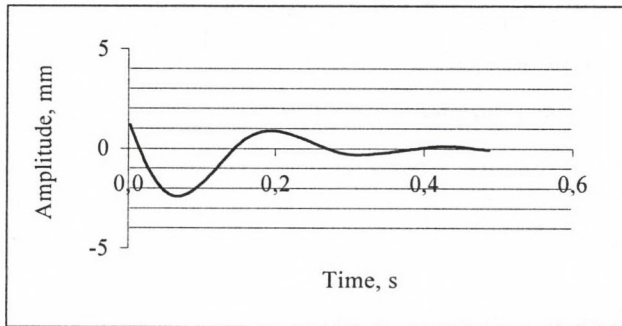

Fig. 9 Amplitude versus time curve of a free oscillating trunk

From the pre-stressing of the cherry-tree trunk an apparent spring constant of 0.007 mm/N was calculated. Evaluating the curve on Figure 9, Eqn 7 and 8 resulted  $k = 12600$  Ns/m. The reduced tree mass, calculated according *Rayleigh's* method (Eqn 11) gave  $m = 130$  kg.

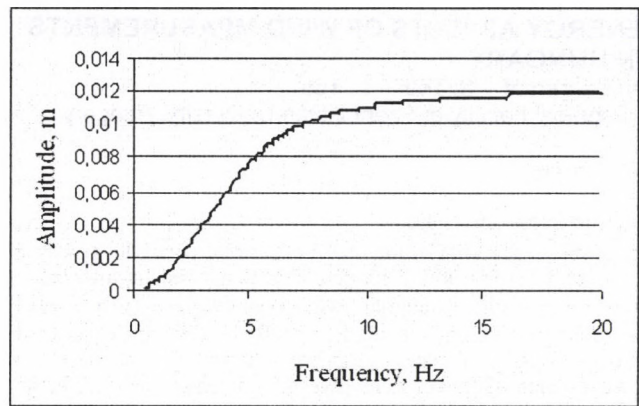

Fig. 10 Amplitude versus frequency curve of the 3 element model

The amplitude versus frequency curve of the simple 3 element model is shown on Figure 10.

### Conclusions

- Although the fruit trees have infinite number of degrees-of-freedom optimal frequencies can be find for shaking them efficiently.
- The frequencies belonging to peak accelerations refer to the natural vibration modes of limb elements.
- The tree methods described above resulted similar frequencies for optimal shaking: those are in the range 10-12 Hz.
- The finite element model results coincide well with those of the real trees, which prove the right setup of the model.
- Even the simple 3 element model is appropriate for shaker harvest studies.

### References

- [1] Ludvig G (1973). Gépek dinamikája. [Dynamics of machines] Műszaki Kiadó, Budapest, 556.
- [2] Láng Z., Csorba L. (2004): Comparing limb shapes of cherry trees using finite element method (FEM). AgEng2004 Conference Full papers, posters and abstracts, ISBN963 9058 15 7, 1-9 p. (CD ROM-on)
- [3] Broch, J.T. (1980): Mechanical Vibration and Shock Measurements. Brück & Kjaer, 370.

# ENERGY ASPECTS OF WIND MEASUREMENTS IN HUNGARY

N. Schrempf – G. Tóth – L. Tóth  
 Technical Faculty of Szent István University, Hungary

## Objectives

The main objectives are:

- to analyse the data of long-term measuring at several places, to show our experiences, and find out the trends and the criterions
- to analyse the Hungarian wind characteristic (wind speed, wind direction, the Hellmann's coefficient, the expectable energy production etc.), after the interpretation to show the Hungarian specialities, to give recommendation to selection the installation place, the mode of the measuring, and the recommended tasks during the analysis
- to define the correct parameters for the investors and the manufacturers, which help them to choose the best solution and best efficient wind generator
- by means of the analysing the Hellmann's coefficient to give an input data's to the Hungarian wind atlas, and a control data's locally or all around the country

## Material and method

During our analysis we researched mainly the wind profiles which affect the height of the windmills, and further wind characteristics which have influence on the energy production. To confirm our theses, we created a wide database by measuring which we made in several places for several months or years. We got these data base from the following measurements:

- several single, own measuring,
- from the data base of National Meteorological Service (Országos Meteorológiai Szolgálat, OMSZ),
- data of other, long-run measuring, and
- from the data of the existing wind generators in Kulcs and Mosonszolnok.

During the measuring the special wind metering equipments measure the wind speed and wind direction values per second and the data logger register the 10 minutes average values and their scattering.

The analysis begins after the read-out of the data's. We have been calculated the huge data set by own written software (macro) and with some special programs. The results and diagrams could help to work up the new relations.

We used during the measuring the following equipments:

- cup anemometer,
- wind-direction indicator,
- digital with PC connection data logger, with solar cell,
- SODAR wind metering equipment – from OMSZ.

We used for installing the measuring instruments the following instruments:

- portable tubular scaffolding,
- portable telescopic mast,
- portable lattice tower,
- other existing constructive works e.g. GSM tower, chimney, water-tower,

Heading of the data base

hónap, nap, év	óra, perc	v (átlag) dm/s	v (max) dm/s	v (min) dm/s	$\sigma_v$	v (átlag) dm/s	v (max) dm/s	v (min) dm/s	$\sigma_v$	szélirány °-ban	$\sigma_\alpha$
Időpont		Anemométer 50 m				Anemométer 25 m				Szélirány	
A	B	C	D	E	F	G	H	I	J	K	L
12/13/01	00/10	26	29	24	0	24	27	20	1	257	0
12/13/01	00/20	29	32	25	1	26	29	21	1	260	0
12/13/01	00/30	29	32	26	1	26	28	22	1	269	5
12/13/01	00/40	27	29	24	1	22	25	17	1	262	0
12/13/01	00/50	27	31	25	1	23	26	20	1	265	9
12/13/01	01/00	27	29	24	1	22	26	18	1	267	0
12/13/01	01/10	27	30	23	1	22	26	19	1	268	6
12/13/01	01/20	25	27	23	1	21	24	17	1	271	6
12/13/01	01/30	24	27	21	0	19	22	17	0	277	9

$\sigma_v$  = Variation coefficient of data (%)

## The main principles

Weibull distribution function (%)

$$f(v) = \frac{k}{c} \left(\frac{v}{c}\right)^{k-1} e^{-\left(\frac{v}{c}\right)^k} \quad (1)$$

Rayleigh distribution function (%)

$$f(v) = \frac{\pi \cdot v}{2 \cdot v_d^2} \cdot e^{-\frac{\pi}{4} \left(\frac{v}{v_d}\right)^2} \quad (2)$$

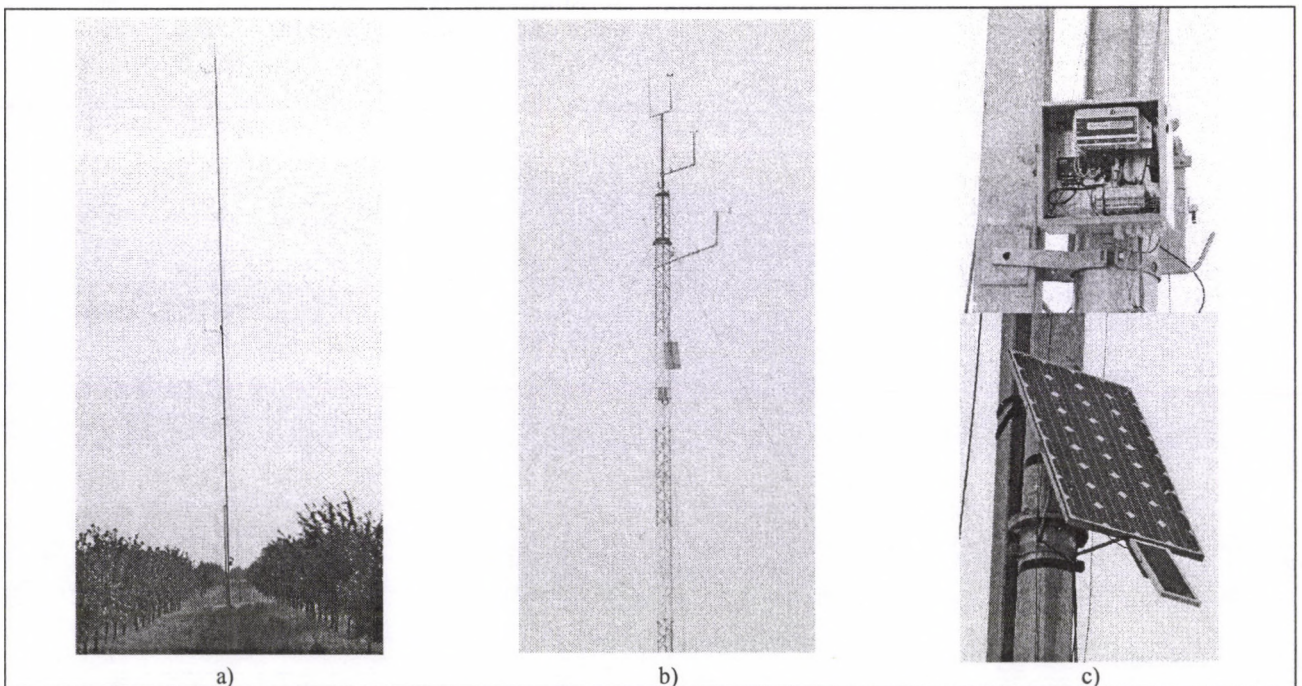

Fig. 1 Setting of the measuring instruments  
 a) telescopic mast, b) lattice tower, c) data logger, solar cell

Hellmann coefficient (m/s)

$$v_2 = v_1 \left( \frac{h_2}{h_1} \right)^\alpha \quad (3)$$

Rated power of generator (kW)

$$P_n = \eta_e \frac{\rho}{2} A_2 v_n^3 \quad (4)$$

Annual expected energy production (kWh/year)

$$E = P_{nd} t_{év} = K_F P_n 8760 \quad (5)$$

The measurements are going on up to this day all over the country. We have to continue the analysis that we could look clearer our potential and we could create the correct wind atlas of Hungary.

**The main issues of the measurements**

We have done manifold analysis. We show some examples about the trends and identification of the correspondences here which do not represent the whole database composed of 10-minute, daily, weekly, monthly and yearly data.

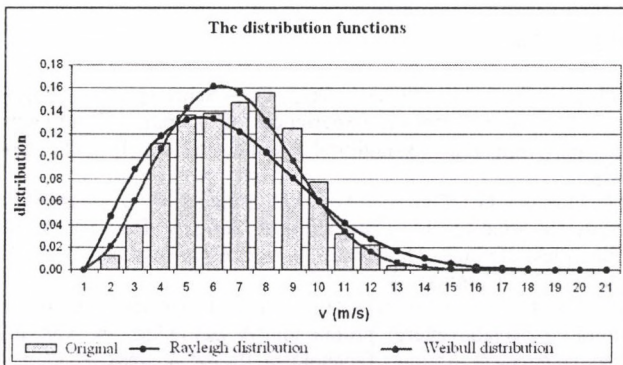

Fig. 2 Histograms by Rayleigh and Weibull distributions

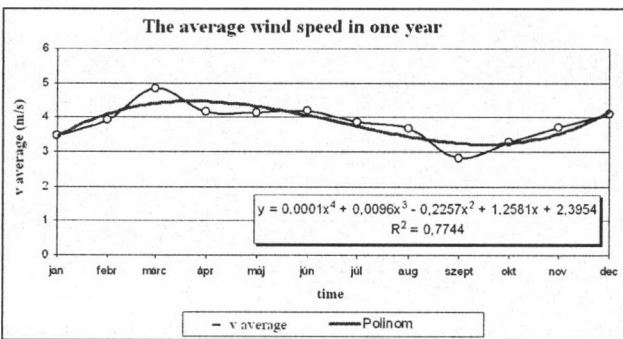

Fig. 3 The trends of the average wind speed as the year progresses

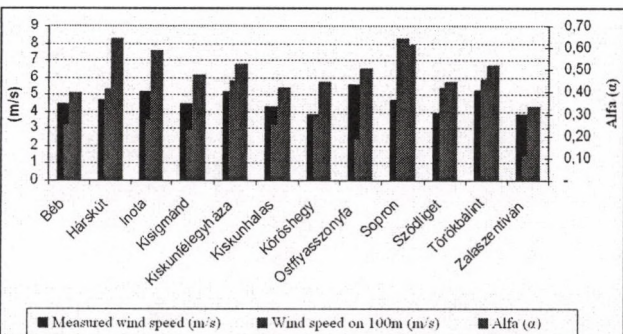

Fig. 4 The measured and the calculated data at several locations

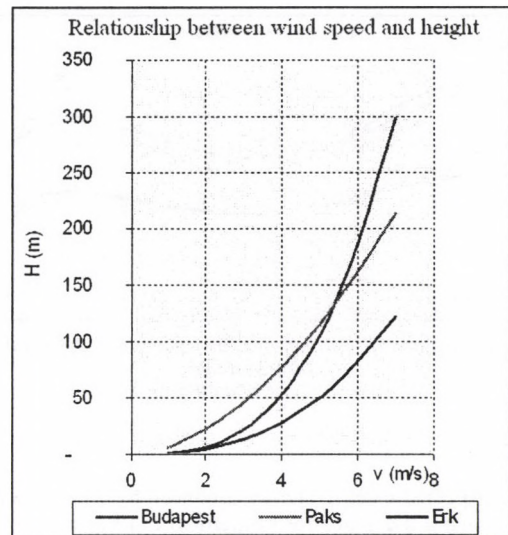

Fig. 5 The wind profiles in 3 different orographic places (according to long-term measurements)

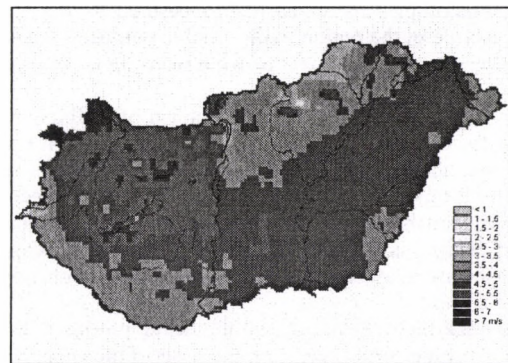

Fig. 6 The Hungarian wind map in 50m

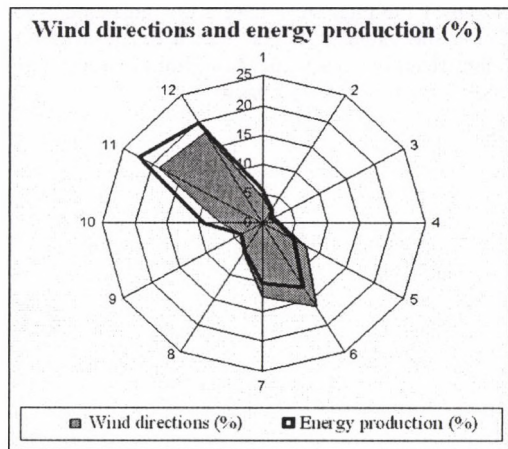

Fig. 7 The main wind directions and the probable energy productions

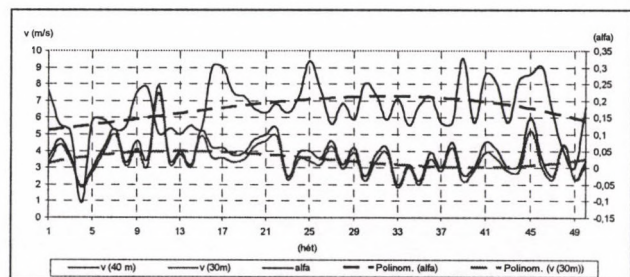

Fig. 8 Course of the alpha coefficient and the average wind speeds during 1 year on a good orographic place

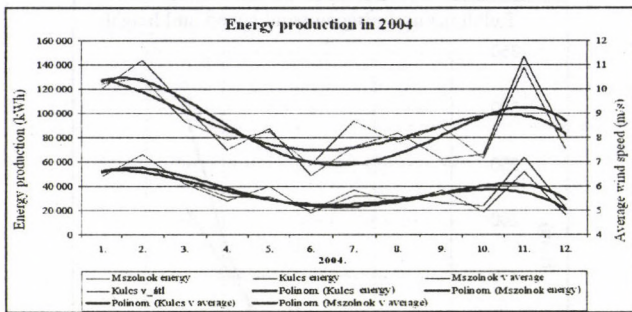

Fig. 10 Energy production with existing windmills in 2004 Kulcs and Mosonszolnok Enercon E-40, 600 kW (rated)

## Conclusions

1. The expected electric energy produced by wind-power stations (knowing the generator properties) can be predicted with correct accuracy (3 to 7 %) in Hungary as well through local wind measurements of energetic purpose on the site (determined with geographic coordinates) and the processing of the conventional climatologic, many-year data measured by the meteorological service in the region, with suitable purpose – depending on the average energy content of wind referring to the examined period.
2. It is required to determine the factor  $\alpha$  of Hellmann's relationship for calculations of the average wind speed for a given site and greater heights (100 to 150m) or the wind profile but  $\alpha$  can be used only if the flow conditions are not disturbed in the very environment of the measurement point. In Hungary, the value of factor  $\alpha$  is between 0.2 and 0.5 in the height range from 25 to 60m as measured in the regions showing advantageous wind potential.
3. The maximum deviation of the wind profile determined with the average wind speeds, on the basis of the energetic wind measurements is given according to the changing of the times of day – the value of factor  $\alpha$  is the minimum in the midday hours ( $\alpha \approx 0.0$  to 0.1) and then the stream is the most equalized. In the night hours, the value of factor  $\alpha$  as a function of height increases significantly (to a value 2 to 3 times larger than the basic) and the stream is less equalized.

4. According to the measurements carried out in several places (in co-operation with the party of consortium of SZIE), advantageous results can be expected from the wind power stations only at generator heights above 100m in conditions of Hungary (ground surface, wind climate). The country has got more areas where the wind potential makes possible economical energy production i.e.  $v_a > 6.0$  m/s at an engine-nacelle height of  $H > 100$ m

5. In orographic areas showing greater diversity, wind measurement data bases for modelling later wind parks can be produced only by anemometers installed at greater heights and more points (minimum 3 devices in the height range between 50m and 90m). For the calculation of the expected yearly energy production, the change of factor  $\alpha$  by height has to be computed projected on all measured wind directions averagely but it has to be determined at every wind direction (sector) one by one because there is a statistically definite relationship between the wind direction and the energy production.

6. Between the wind directions and factor  $\alpha$  or the magnitude of the wind speed and the wind direction alone, there are not relationships ensured statistically. The deviation of the average wind speeds increases with the growing of the average. The value of factor  $\alpha$  changes continuously during the year as well – it reaches the maximum value at the periods of the summer having lower wind speeds accordingly then it can be talked about more equalized wind courses.

## Publications

- [1] Tóth, L. – Horváth, G. – Tóth, G. – Schrempf, N. – Fogarasi, L. (2003): Domestic Experiences of Operating Wind Generators, Hungarian Agricultural Engineering Nr. 16/2003, 63-65p.
- [2] Horváth G., Tóth L., Tóth G., Stelczer B.: A feasibility study for wind turbine installation in Hungary. Deutsche Windenergiekonferenz, Deutsches Windenergie-Institut, Wilmshaven, 2000. június 7-8.
- [3] Tóth L. – Schrempf N. – Tóth G. (2004): Characterization of wind - expectable energy production (A szél jellemzése, várható energiatermelés), Áram és Technológia, III. évf. 4. szám, 34-37. p.
- [4] Patay István (2003): A szélenergia hasznosítása (Utilization of wind energy), Szaktudás Kiadó Ház, Budapest

## IMPROVED THEORY OF HYDRAULICAL ATOMIZATION

István Sztachó-Pekáry

College of Kecskemét, Kecskemét

In this study our pervious two – against surface tension and against viscous shear force based – theories were improved. In the new, complex equation we consider force balance for a droplet separating radially from a liquid sheet. We consider that a small mass  $\Delta m$  with a radial velocity is separating into a droplet. The analysis of the equations revealed that the calculated effect of drag force for  $\Delta r=0d-25d$  on drop velocities was negligible for a water spray in still air; furthermore the assumptions that a droplet separates only laterally did not prove to be right; and erroneous estimation of dynamical pressure  $p$ ; and inappropriate incorporation of spray angle  $\alpha$  were also revealed.

### Introduction

As it has been observed that during the atomization process first a liquid sheet arise, followed by a disruption of ligamentation, and finally the separation of droplets comes. Separation of droplets is essentially caused by their internal motion relative to the spray body [AMBERG – BUTLER 1969], [LÁSZLÓ, 1979]. The theoretical process of atomization of liquid sheet assumes that the droplet inertia has to exceed surface tension in order to separate. It is further assumed that droplets and sheet body move with the same longitudinal velocity, thus atomization is caused by the lateral component of the inertia only, as has been seen in Fig. 1. by GERENCSÉR [1981].

### Previous theories

The next two theories show that the liquid atomizes by forming a sheet, which disrupts into liquid ligaments and further into droplets [SZTACHÓ-PEKÁRY, 2004].

- The *surface tension hypothesis* was obtained by equating  $x$  component of the inertia force (dynamical pressure times drop sectioning area)

$$d = \text{const.} \cdot \frac{\sigma}{p \cdot \text{tg}^2 \alpha} \quad (1)$$

where

$d$  - the droplet diameter [m]

$\sigma$  - the surface tension [ $\text{N m}^{-1}$ ]

$p$  - the pressure of the liquid before the drop separation [Pa]

$\alpha$  - half spray angle [rad]

- The *shear hypothesis equation* was obtained by equating the  $x$  component of the inertia force and the resisting shear force (viscosity times sectioning area times the gradient of the lateral velocity with respect to the droplet dimension)

$$d = \text{const.} \cdot \frac{\nu}{\sqrt{\rho_{\text{liq}} \cdot p \cdot \text{tg} \alpha}} \quad (2)$$

where

$\nu$  - the kinematical viscosity of the liquid [ $\text{m}^2 \text{s}^{-1}$ ]

$\rho_{\text{liq}}$  - the density of the liquid [ $\text{kg m}^{-3}$ ]

### Equation grounded on surface tension and viscosity, considering the gravity and the effective-drag

In this section we consider force balance for a droplet separating radially from a liquid sheet. Consider that a small mass  $\Delta m$  with a radial velocity  $v_{\Delta m}$  is separating from the liquid sheet into a droplet diameter  $d$  (Fig. 1). Let  $v_{\Delta m} = v_1$  when the mass is within the liquid sheet, and  $v_{\Delta m} = v_2$  when the mass is formed into a droplet. Assume that the droplet is

separating under the combined effect of radial components if inertia and gravity forces  $F_r$ , with the resist force  $R_r$ . In this case  $F_r = F_a + F_g$  and  $R_r = F_\sigma + F_\mu + F_{C_w}$  (Fig. 2).

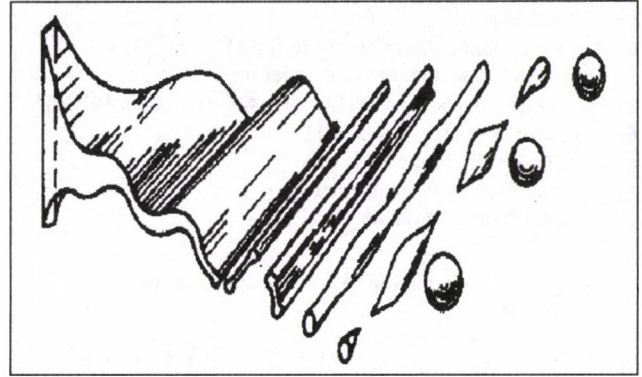

Fig. 1 The phases following one another in the atomization process [GERENCSÉR, 1981]

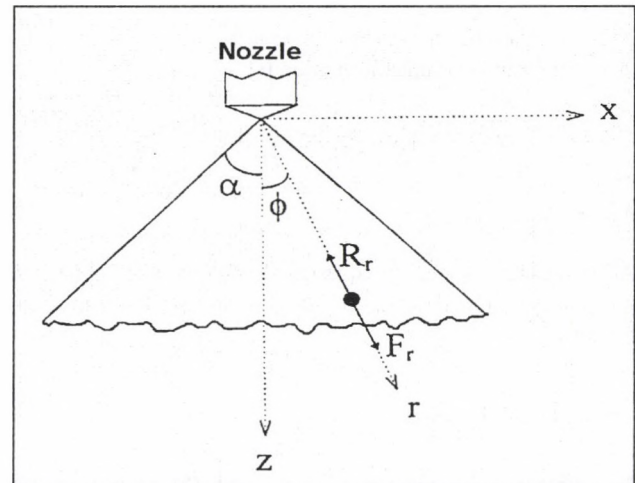

Fig. 2 The radial forces acting on the small mass  $\Delta m$

The acting forces are shown in Fig. 2. The balance equation is:

$$F_g + F_a = F_\sigma + F_\mu + F_{C_w} \quad (3)$$

where

$F_g$  - the gravity force acting on small mass  $\Delta m$  [N]

$F_a$  - the inertia force acting on small mass  $\Delta m$  [N]

$F_\sigma$  - the surface tension force acting on small mass  $\Delta m$  [N]

$F_\mu$  - the viscosity force acting on small mass  $\Delta m$  [N]

$F_{C_w}$  - the effective-drag force acting on small mass  $\Delta m$  [N]

Substituted the single forces into equation (3)

$$\Delta m \cdot g \cdot \cos \phi + \Delta m \frac{dv_{\Delta m}}{dt} = d \cdot \pi \cdot \sigma + \frac{1}{4} \pi \cdot d \cdot \mu \cdot v_{\Delta m} + \frac{1}{2} A \cdot C_w \rho_{\text{air}} \cdot (v_{\text{drop}} - v_{\text{air}})^2 \quad (4)$$

where

$\Delta m$  - to droplet formatting liquid mass:

$$\Delta m = \pi \cdot d^3 \cdot \rho_{\text{liq}} / 6 \quad [\text{kg}]$$

$g$  - the gravity acceleration [ $\text{m s}^{-2}$ ]

$\phi$  - the angle that defines the radial direction along which a droplet is moving:  $0 \leq \phi \leq \alpha$  [rad]

- $v_{\Delta m}$  - the velocity-difference of small fluid-mass  $\Delta m$  before ( $v_1$ ) and after ( $v_2$ ) the formation of droplet:  
 $v_{\Delta m} = v_1 - v_2$  [m s<sup>-1</sup>]  
 $t$  - the time [s]  
 $\mu$  - the dynamic viscosity of the fluid [N s m<sup>-2</sup>]  
 $A$  - the cross-section of the droplet [m<sup>2</sup>]  
 $C_w$  - the effective-drag coefficient  $\approx Re^k$  [TRITTON, 1988] []  
 $Re$  - the REYNOLD'S- number []  
 $\rho_{air}$  - the density of the air [kg m<sup>-3</sup>]  
 $v_{drop}$  - the velocity of the droplet [m s<sup>-1</sup>]  
 $v_{air}$  - the velocity of the air [m s<sup>-1</sup>]

The term  $\frac{dv_{\Delta m}}{dt}$  in equation (4) can be approximated by:

$$\frac{dv_{\Delta m}}{dt} = \frac{dv_{\Delta m}}{dr} \cdot \frac{dr}{dt} = \frac{\Delta v_{\Delta m}}{\Delta r} \cdot \frac{\Delta r}{\Delta t} \quad (5)$$

where

- $\Delta r$  - the distance traveled by the droplet in time  $\Delta t$  [m]  
 $\Delta t$  - the time of droplet formation [s]

The term  $v_{\Delta m}$  in equation (5) can be estimated by:

$$v_{\Delta m} = v_1 - v_2 \quad (6)$$

Also, the term  $\Delta r/\Delta t$  in equation (5) can be approximated as the average velocity of the droplet during separation from the liquid sheet:

$$\frac{\Delta r}{\Delta t} = \frac{1}{2}(v_1 + v_2) \quad (7)$$

By substituting equations (7), (6) and (5) in (3), further observing that  $C_w = k\left(\frac{v_2}{v_1}\right)^{2n}$  (where  $n \geq 0$ ,  $k > 0$ ) [SIDAHMED, 1997] and  $v_{drop} - v_{air} = \frac{v_1 + v_2}{2}$  [SIDAHMED, 1997]; we obtain:

$$\frac{d^2}{\Delta r} = \frac{12\sigma + 3\mu(v_1 - v_2) + 0,375\rho_{air} \cdot k\left(\frac{v_2}{v_1}\right)^{2n} \cdot (v_1 + v_2)^2 \cdot \Delta r}{\rho_{drop} \cdot (v_1^2 + 2g \cdot \Delta r \cdot \cos\phi - v_2^2)} \quad (8)$$

We deduce that  $\Delta r = d$ . So equation (8) can be written as:

$$d = \frac{12\sigma + 3\mu(v_1 - v_2) + 0,375\rho_{air} \cdot k\left(\frac{v_2}{v_1}\right)^{2n} \cdot (v_1 + v_2)^2 \Delta r}{\rho_{drop} (v_1^2 + 2g\Delta h - v_2^2)} \quad (9)$$

where

- $\Delta h$  - the vertical component of  $\Delta r$ :  $\Delta h = \Delta r \cdot \cos\phi$  [m]

Equation (9) can be written in its component forms. The equation for x components (of  $F_r$  and  $R_r$  in Fig. 2) can be obtained by substituting  $v_1 = v_{1x}/\sin\phi$ ;  $v_2 = v_{2x}/\sin\phi$ ,  $\Delta r = \Delta x/\sin\phi$ :

$$d = \frac{12\sigma \cdot \sin^2\phi + 3\mu(v_{1x} - v_{2x}) \cdot \sin\phi + 0,375\rho_{air} \cdot k\left(\frac{v_{2x}}{v_{1x}}\right)^{2n} \cdot (v_{1x} + v_{2x})^2 \frac{\Delta x}{\sin\phi}}{\rho_{liq}(v_{1x}^2 + 2g\Delta x \cdot \sin\phi \cdot \cos\phi - v_{2x}^2)} \quad (10)$$

Similarly, the equation for the z components is obtained by substituting  $v_1 = v_{1z}/\cos\phi$ ;  $v_2 = v_{2z}/\cos\phi$ ,  $\Delta r = \Delta z/\cos\phi$ :

$$d = \frac{12\sigma \cdot \cos^2\phi + 3\mu(v_{1z} - v_{2z}) \cdot \cos\phi + 0,375\rho_{air} \cdot k\left(\frac{v_{2z}}{v_{1z}}\right)^{2n} \cdot (v_{1z} + v_{2z})^2 \frac{\Delta z}{\cos\phi}}{\rho_{liq}(v_{1z}^2 + 2g\Delta z \cdot \cos^2\phi - v_{2z}^2)} \quad (11)$$

### Numerical analysis of the improved theory

It can be seen that equation (9) is the summation of equations (10) and (11), since  $v_1^2 = v_{1x}^2 + v_{1z}^2$ ,  $v_2^2 = v_{2x}^2 + v_{2z}^2$ ,  $\Delta r^2 = \Delta x^2 + \Delta z^2$  and  $\sin^2\phi + \cos^2\phi = 1$ . In any case, equation (11) is useful for comparison with experimental data when only vertical velocities of droplets and the liquid sheet are known.

Table 1 Data used at the numerical analysis

Sym.	Data and Units	Sym.	Data and Units
$\phi$	0	$\rho_{drop}$	$1.0 \cdot 10^3$ kg/m <sup>3</sup>
$\Delta h$	$\Delta r$	$\rho_{air}$	1.26 kg/m <sup>3</sup>
$\sigma$	$7.3 \cdot 10^{-2}$ N/m [WEAST, 1981]	$k$	0.67 [SIDAHMED, 1997]
$\mu$	$1.01 \cdot 10^{-1}$ Pa s [WEAST, 1981]	$n$	3.5 [SIDAHMED, 1997]
$v_{drop}$	17.93 m/s (assumed)		

Calculations were carried up to 500  $\mu$ m drops. As seen in Fig. 3, drop velocities were not significantly affected by effective-drag when  $\Delta r$  varied from 0 to 25d (25d = 12.5 mm for  $d = 500 \mu$ m). However, the difference between the velocity of the liquid sheet (at breakup) and the velocity of the largest droplet (500  $\mu$ m in Fig. 3) increased slightly with  $\Delta r$ . Thus, the effect of effective-drag during disintegration of liquid mass  $\Delta m$  and its subsequent formation into a drop can be neglected for water sprays in still air.

It is worth mentioning that drop velocities that are extremely close to the liquid sheet velocity can yield unrealistically large drop size {equation (9)}. This means that such remarkably close velocities – which mainly represent drop formation by gravity – are very unlikely to occur in real sprays.

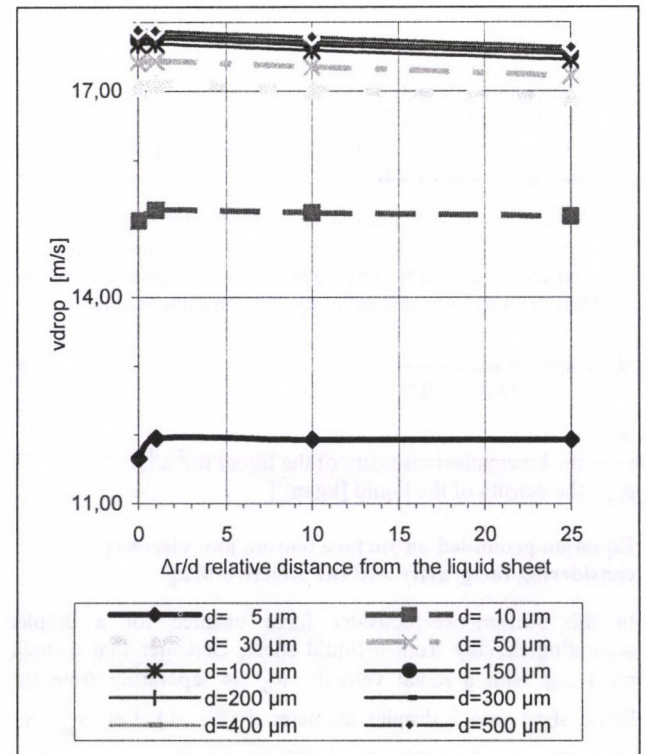

Fig. 3 Calculated effect of effective-drag on velocities of droplets (the liquid sheet velocity at breakup was assumed 17.93 m/s)

## Summary and conclusions

New drop-size/velocity correlation equations were developed based on the improved force balance equation, assuming that a droplet disintegrates from the liquid sheet radially under the combined effect of its inertia  $a$ , gravity  $g$ , surface tension  $\sigma$ , viscosity  $\mu$ , and effective-drag  $C_w$ . The effective-drag was assumed to account for the effects of viscous drag, air entrainment, and mutual interference of droplets in a spray. Analysis of the equation giving the droplet diameter revealed that:

1. The calculated effect of effective-drag – for  $\Delta r = 0 - 25d$  – on drop velocities was negligible for a water spray in still air.
2. The assumption at the former hypothesis – based only on or, respectively – the lateral separation of droplets is false. The former hypotheses that droplet separates only laterally and the disintegration is due either to viscosity  $\mu$  or to surface tension  $\sigma$  is proved to be erroneous.
3. In plant protection using the method of hydraulic atomization the droplets are separating under the common effect of surface tension and viscosity.

## References

- [1] AMBERG, A. A. – BUTLER, B. J. (1969): High speed photography as a tool for spray droplet analysis. ASAE Paper No. 69-140. St. Joseph, Mich.: ASAE
- [2] GERENCSEK A. (1981): A növényvédelemben használatos lapossugarú szórófejek néhány kérdése. *Járművek és Mezőgazdasági Gépek*, 28. k. 7. sz. 241-248 p.
- [3] LÁSZLÓ A. (1979): A hidraulikus cseppképzés néhány áramlástanai problémájának vizsgálata, különös tekintettel a cirkulációs szórófejekre. *ATEK, Keszthelyi Mg. Kar Közleményei*, Keszthely, XXI. k. 4. sz. 28 p.
- [4] SIDAHMED, M. M. (1997): Transport model for near nozzle fan sprays. *Transaction of the ASAE*. 40.k. 3. sz. 547-554 p.
- [5] SZTACHÓ-PEKÁRY I. (2004): Force Based Atomization Theories for Spray Nozzles. *Hungarian Agricultural Engineering (Gödöllő)*, 17.k. 26-28 p.
- [6] TRITTON, D. J. 1988: *Physical Fluid Dynamics*, 2nd ed., Oxford University Press
- [7] WEAST, R. C., 1981: *Handbook of Chemistry and Physics, 61st ed.* Boca Raton, FL: CRC Press, 45.p.

# NEW METHODS FOR THE EVALUATION OF HYDRO MOTORS

S. Török – Z. Bártfai  
Szent István University, Gödöllő

## Introduction

Evaluation of the technical condition is mainly based on testing and comparing the above mentioned parameters with the values given by the manufacturer. If the difference is higher than the permitted, the hydro motor must be restored or changed. The question is how much can be the permitted difference?

In the practice the evaluation of the technical condition happens considering the RPM. The r.p.m. is recorded at the rated loading level. Comparing it with the value given by the manufacturer, the difference should not exceed 20%. As it can be seen the determination of the technical condition is limited to only one work point. This is a disadvantage of this method.

At the Institution of Systems Engineering of the Szent István University (SZIU) we have worked out a new measuring method with the following aims:

- It has to be universally applicable for the evaluation of the technical condition of the hydro motors on the whole range of the input flow curve.
- It must be irrespective of the type, and size of the hydro motor and the unit of the measured parameters as well.

With the help of the developed method the evaluation process is divided to the following stages: as the first step the input flow curve has to be recorded (input flow versus pressure drop). In the next step the equation of the graph must be determined. Having known the rise of the curve the technical condition can be evaluated.

## Discussion

The developed method for evaluating the technical condition is introduced in the following example showing the test procedure of a gear pump.

### Technical data of the gear pump:

Manufacturer:	Monori Mezőgép
Relative input flow	$q=12,5 \text{ cm}^3/\text{ford.}$
Max. pressure drop	$\Delta p=160 \text{ bar}$
Rated r.p.m	$n_n=1500 \text{ min}^{-1}$
r.p.m. range	$n=500-3000 \text{ min}^{-1}$
Max. torque	$M_{\max}=30 \text{ Nm}$
Type of hydraulic oil	Hydro 30

All the examinations were carried out at the laboratory of the Institution of Systems Engineering. The test procedure ran on a hydrostatic measuring bench designed by our team.

Figure 1. shows the main elements of the measuring bench:

- I. Hydraulic supply unit
- II. Hydro-motor circle
- III. Pump circle

### Elements of the hydrostatic test bench:

1.	Hydraulic supply unit	500 TE 40-160
2.	2/2 directional valve and therm.	AVTB 3N 3252
3.	3 ways flow-stabiliser	3 FRM 10-20/SQL
4.	Measuring-turbine	HF 15/2-250
5.	Hydro-motor	12.5 TGL 10860
6.	Torque-meter	MOM (0-50 Nm)
7.	Pressure-gauge	213. 100. 25 (VIKA)
8.	Pressure-gauge	213. 100. 250 (VIKA)
9.	Choke-valve	MG 10G
10.	Oil-water heat exchanger	OHV-315
11.	Magnet filter	MS 63

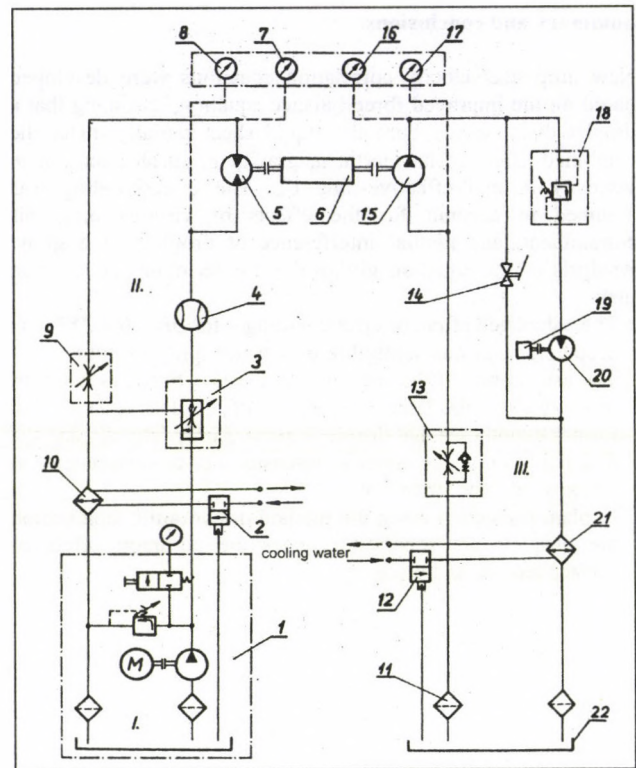

Fig. 1 The hydrostatic test bench

## Results

The examined hydro-motor was placed on the test bench (no. 5) as it is shown in the Figure 1. The needed hydraulic energy was supplied by the hydraulic supply unit (no.1.). The role of the hydro-motor circle (III) was braking.

The examined gear hydro-motor curves -input flow vs. pressure- can be studied in Figure 2. During the test the r.p.m. was constant while the pressure drop ( $\Delta p$ ) and the volume flow ( $Q$ ) were registered.

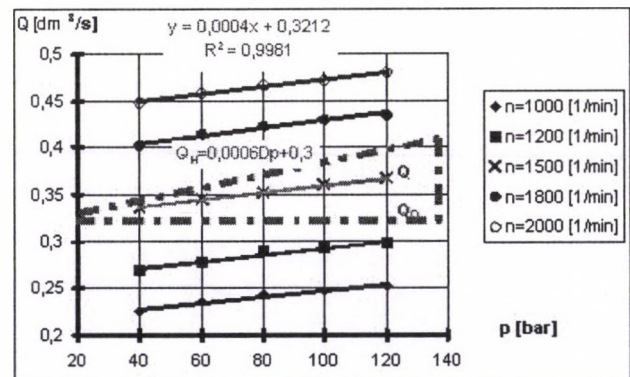

Fig. 2 Input flow curves of the examined hydro-motor

12.	2/2 directional valve and therm.	AVTB 3N 3252
13.	Choke valve	MK 20 G
14.	Manual stopper	A20 TGL 21575
15.	Hydraulic pump	12,5 TGL 10859
16.	Pressure-gauge	213.100.250 (VIKA)
17.	Vacuum-gauge	213.100 -I/+1.5 (VIKA)
18.	Pre controlled pressure limiter	DB 10-30/315LJ
19.	r.p.m transmitter	5ES-1/4.600.03.
20.	Piston measuring motor	A2F 10R 4P1
21.	Oil-water heat exchanger	OHV-315
22.	Oil tank	250 dm <sup>3</sup>

Determination of the technical condition based on the input flow curves analysis. In the diagram the dotted lines sign the area where the curve regarding the adequate technical condition must be settled. The recorded input flow curve (Q) was not compared with the original one issued by the manufacturer, but it was evaluated comparing with the geometrical input flow (Q<sub>0</sub>). The value of the volume flow, where the input flow of the hydro-motor is 30 % higher than the geometrical value can be considered as the practicability limit (Q<sub>H</sub>). This 30 % limit is built up of two components: the very new hydro-motors can be featured by approx. 10 % of growth comparing with the Q<sub>0</sub>. On the other hand some further 20 % growth is permitted as the result of the operational wear.

The value of the geometrical input flow (Q<sub>0</sub>) must be given for determining the technical condition. Measuring the input flow of the hydro-motor in unloaded condition (Δp=0) an acceptable practical result can be produced.

The mathematical equations of the practicability limit (Q<sub>H</sub>) differ depending on the size of the hydro-motor. A generally applicable mathematical formula can be devised using a coordinate system having no dimensions on the vertical axis. By this way the equation can be independent from the dimension (see Figure 3.).

Dimension-less form of the equation of the input flow curve is the following:

$$\frac{Q}{Q_0} = m \frac{\Delta p}{\Delta p_n} + 1 \quad (1)$$

$$m = \frac{\Delta p_n}{\Delta p} \left( \frac{Q}{Q_0} - 1 \right) \quad (2)$$

- Q = Real volume flow [dm<sup>3</sup>/s]
- Q<sub>0</sub> = Geometrical volume flow [dm<sup>3</sup>/s]
- Δp = Real pressure drop [bar]
- Δp<sub>n</sub> = Nominal pressure drop [bar]
- m = Abruptness of the curve [1]

Generally, the technical condition of the hydro-motor can be acceptable, when the value of the abruptness of the curve is:

$$0 < m < 0,3$$

During the test the hydro-motor is not to be loaded to the maximum pressure drop. This is one of the main advances of the method. This can be an important point of view, when hydraulic tester is used for measuring. As it can be seen in figure 3, the abruptness of the input flow curve can be determined by the help of a vertical abscissa. Let's see an example: Let the hydro-motor be loaded 50% of the rated pressure drop (Δp<sub>n</sub>). Measure the volume flow (Q) and the

pressure drop (Δp). The geometrical volume flow (Q<sub>0</sub>) was measured previously with no load (Δp=0). The abruptness (m) of the input flow curve can be determined with the help of the above mentioned equation. Having known this information the technical condition of the hydro-motor can be determined as well. Certainly the reliability of the method can be increased by replying the test procedures in the loading range.

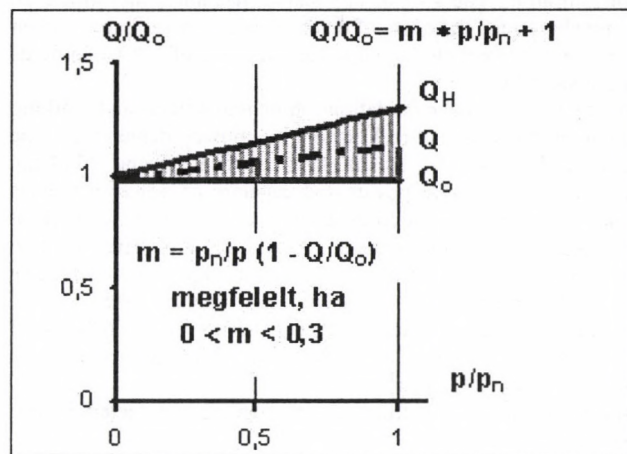

Fig. 3 Determination of the technical condition of hydro-motors

### Summary

The most important elements of the method worked out for facilitating the determination of the technical condition of hydro motors:

- Recording the curve of input flow (versus pressure),
- Determination of the geometrical flow,
- Determination of the rise of the flow curve. Having known this information, the usability of the hydro motor can be decided.
- In the case of the special hydro motors it is practical to change the referenced utility interval (30 %).

The applicability of the presented method is irrespective of the type, and size of the hydro motor and the unit of the measured parameters. Further advantage of the method is the geometrical input flow as the base of reference can be defined well even if the essential technical data is not given by the manufacturer.

### References

- [1] TÖRÖK, S.: Test methods for determining the operational parameters of the hydraulic systems. XXXVI. National Conference on Agricultural Mechanization, Gyöngyös, 2000.
- [2] TÖRÖK, S.: Hydraulic tests. GATE, Gödöllő, 1988.

## RELATIONSHIP BETWEEN FARM SIZE AND MECHANIZATION

J. Hajdú – L. Gockler

Hungarian Institute of Agricultural Engineering, Gödöllő

The Hungarian farm and property structure has been changing continually recently. The rapid devolution is followed by a slow concentration. The size of applicable machines, the utilization of machines and the costs of machine work basically depend on the size of property to be tended and the size of cultivated fields at the same time.

Practical and model calculations show that power- and working machine demand as well as engine power demand can be reduced by 50-66 % specifically between 10 and 1000 ha. Increasing the engine power and capacity of power machines results in a sharp reduction of the cost of machine work at performance categories between 40 and 100 KW. The reduction is moderated afterwards but is still significant. Machine demand, performance provision, the volume and cost of machine work can substantially be reduced – by 75-66 % – on 1 to 10 ha fields, on a field size exceeding 20 hectares the decrease is not so significant.

Major statements resulting out of surveys conducted in this issue:

- The *disintegration of property units*, the changes in land ownership, the dissolution of the former conformity among the major branches of production have unfavourably effected the mechanization of agriculture. Partly due to this fact, among others, the agricultural output has notably declined as a result of the changes. The newly established *private- and family* (small) farming units suffer from the lack of capital and equipment from time to time, while the slow procession of modernisation causes difficulties to the *economic organizations* and harms their competitiveness.
- The production volume of the major plants was changing hectically in the '90-es and has been sharply decreasing since the end of the decade, the stability of production has been declining and also the quality of products has caused trouble several times.
- The rapid decrease of livestock, the change of ownership of establishments and settlements has led to the rapid decay of means together with the decline of technological standards and an increasing burden on the environment caused by the settlements. Owing to the fact that production costs have also increased the competitiveness of the animal breeding branches has also notably declined.
- The "re-privatisation" of arable land and the changes in the property structure have caused a breakage in the agricultural *investment* processes as well and in the early nineties *machinery investments* reached the nadir. The defaults and cancelled developments arising from this could not have been compensated till today.
- The machinery sized for large-scale farming and well utilized earlier have mostly cascaded the operation of same has become uncontrollable. A paradox situation has been created in the utilization of machines due to the fact that besides unprovided areas there has been surplus capacity in some other areas. The establishment of plant machinery corresponding to the size of farming unit and to the activity of same is progressing slowly. The modernization of the technical basis of quality production and the development of homogeneous complex machine systems can be expected on the long term only.
- The concentration of properties has – though slowly – recently started. This is also favourable for technical modernization. The number of plants has decreased and the expressly commercial farms have gained strength. According to the last review of KSH (GSZÖ 2003) the number of private

farms decreased by 20 % and that of economic organizations by 7 % between 2000 and 2003. The number of expressly commercial farms increased to 90 thousand from 77 thousand.

- Considering the plant structure known today the future plant structure which can build the basis of the competitive Hungarian agriculture can be developed on the basis of the about 75.000 private farms using 36,1 % i.e. 1.427 thousand hectares of the cultivated area of this plant type and on the about 1.360 farming units representing 17,4 % of the economic organizations managing on a territory over 300 hectares utilizing 85 % i.e. 2.941 thousand hectares of the area cultivated by this sector. This corresponds with the opinion of the experts of Nemzeti Agrár Kerekasztal (National Agrarian Round-table, NAK) who predict a future Hungarian agricultural property-structure with 80-100 thousand viable private commercial farms and 6-7 thousand economic organizations. In the national plant structure presented hereby the average size of arable land would be over 100 hectares per farming unit, which can still be considered small in view of rational machine utilization, but can be accepted as a reality and would be 5,6 times bigger than the present standard property size.
- The mechanization of a typical (dealing in crop growing as well as animal breeding) agricultural factory tested on the basis of model-calculations graded as viable according to EU methodology and test factory data can be acceptably economical on an area over 200 hectares, and the machine investments resp. costs of machine use are favourable over 500 hectares (Magó 2002). Taking the above into consideration the further property concentration would by all means be advantageous in view of the mechanization of agriculture. [3]
- National statistical data (ÁMÖ 2000) also prove that the specific machine demand subject to property size decreases sharply between 10 and 500 hectares, afterwards the decrease is moderated but still significant. The same tendency of cost reduction can be experienced in case of the expansion of machine capacity and field size (Magó 2001) [2]. All these facts show that investments on machinery can be modulated favourably by the extension of property size, field size and machine performance and the specific cost of machine work can be reduced and the competitiveness of production increased hereby. (diagram 1-5.)
- Parallel to property concentration the *specialization of plants* also offers further advantages in view of mechanization and the costs of machine work. The machine investment and machine work of farming units specialising in one individual profile can be realized at lower costs, furthermore, they are more competitive in view of productivity and quality.
- The proportions between the two major branches of agriculture are expected to shift towards *crop growing*. Considering the future EU regulations among others the productive output of crop growing is increasing whereas that of animal breeding is decreasing, the proportion of agricultural services is growing and the environmental protectionist (land cultivation and maintenance) function is strengthening at the same time. All these notably affect the inner structure of mechanization and investment priorities.
- The proportion of wheat production within *crop growing* is expected to remain decreasing later on stagnant. The share of industrial crops, vegetable crops and alternative (other) crops of the sown area is growing at the same time. There are no significant changes in the territorial rates of vineyards and fruit plantations but due to the renewals the technology is shifting towards more complex mechanization. Closer attention is to be paid, therefore, to mechanization by new plantations and reconstructions. The quality commodity production calls for the development of all branches of the system as a total.

- The changes expected in the *structure* of crop growing demand quality orientated, means sparing and efficient, complex solutions for the mechanization of wheat, industrial crops and forage production, while in the mechanization of vegetable, vine and fruit production bigger emphasis is laid on creating the technical basis for a quality production up to the EUREGAP requirements.
- By crop growing the intensifying differentiation of the different *levels* (intensive, semi-intensive, extensive) of farming resp. *production methods* (organic, endemic, etc.) is to be taken into consideration and mechanization is to be in compliance with it. Mechanization is also to contribute to the preservation of the ecological potential of agriculture by ensuring the sustainable development for the agriculture to become a multifunctional organic overall system within the framework of multifunctional rural management.
- In the field of post-harvest the expansion of up-to-date conserving warehousing capacities promoting market accession is to be considered a prior task, first of all the development of grain drying and storing plant technologies and the modernization of public warehouses in view of the market requirements together with the intervention requirements and regional makings.
- In *animal breeding* the development of the mechanization of concentrated settlements with a higher head of stock mostly operated by economic organizations comes to the front. Mechanization is to promote the retention of profitable production levels and the speeding up of the compliance with animal welfare rules and with the regulations of environmental protection. The creation of the balance between forage production and stock breeding is an important requirement.
- The organizations for common machine utilization (machine circles, machine cooperatives and job workers) and professional machine work suppliers play an increasing part in the rationalization of machine investments and machine utilization (Nagy-Magó 2004). [4] The organizations of producers (TÉSZ-s, BÉSZ-s) working effectively along the product lane resp. the GbR-s (Machine Work Supplying PJT-s) supplanting machine circles spreading rapidly in Germany (and serving as a model in Hungary as well) can take part in this. These carry out the ordered work with modern well utilized machines, in the possession of high level technological knowledge at lower cost and mobilize capital invested in assets by the farming units at the same time.
- The *number* of competitive economic organizations undertaking bigger investments by machine investments increased already in the last year and the *share* of more up-to-date power machines and working machines in the investments is growing continually. This fact proves that the demand for competitive modern technics and technology is increasing. A respective modification of the promotional policy can favourably affect this process.
- *Technical expertise* is bound to *expand* with modern mechanization which can contribute a lot to the better utilization of the potentials of new machine constructions. In the different levels of technical training and technical expertise more emphasis should be laid on practical knowledge directly usable in production.
- It would significantly contribute to the development of mechanization and to getting closer to those leading the field internationally if – in accordance with the strategy composed by the Nemzeti Agrár Kerekasztal (National Agrarian Roundtable) – the property concentration would be speeded up, more attention would be paid to professional farming, promotional policy would shift towards efficient quality production, regulations would become more perspicuous and the decisions in connection with same and the promotions would become more rapid and calculable.

#### References

- [1] Hajdú J.: (2001) „A magyar mezőgazdaság technikai felszereltségének mutatói az EU csatlakozás előtt - The indexes of the technical equipment of the Hungarian agriculture before joining the EU”, XLIII. Georgikon Napok, 20-21 September, 2001, No. 2, p. 1100-1105.
- [2] Magó L.: (2001) „Minimális használati költségű traktortpark műszaki-ökonómiai jellemzői az üzemi méret tükrében - The technical-economic characteristics of a tractor pool of minimal utilization cost in view of factory size”, VI. FMTÜ, Cluj, Romania, 23-24 March, 2001 p. 5-8.
- [3] Magó L.: (2002) „A minimális használati költségű szántóföldi erőgéprendszer kialakításának elvi és módszertani összefüggései - The principle and methodological relations of the establishment of a field power machine system of minimal utilization cost”, PhD thesis, SzIE, Gödöllő, p. 129.
- [4] Nagy, I. – Magó, L.: (2004) „Machinery Development Alternatives in Agriculture Based on Farmers Cooperation” 2004 CIGR Int. Conf. Beijing, China. 11-14 Oct. 2004. Vol. 2. p. V-15.

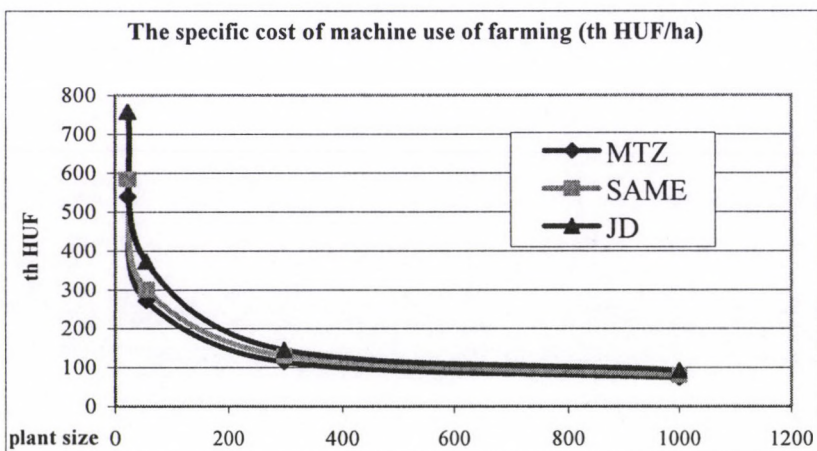
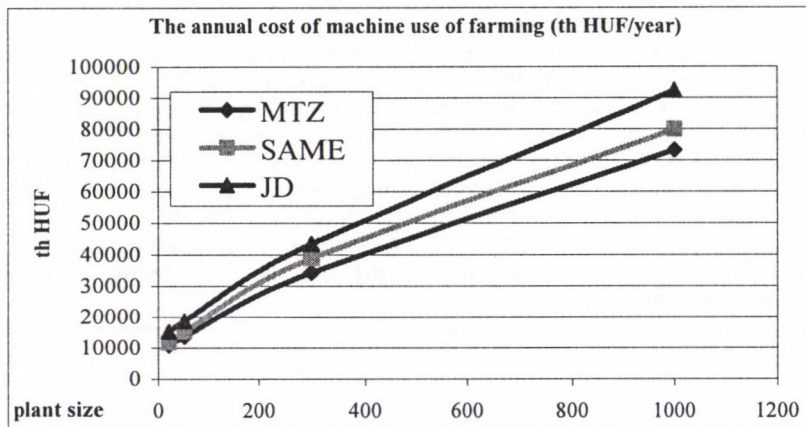
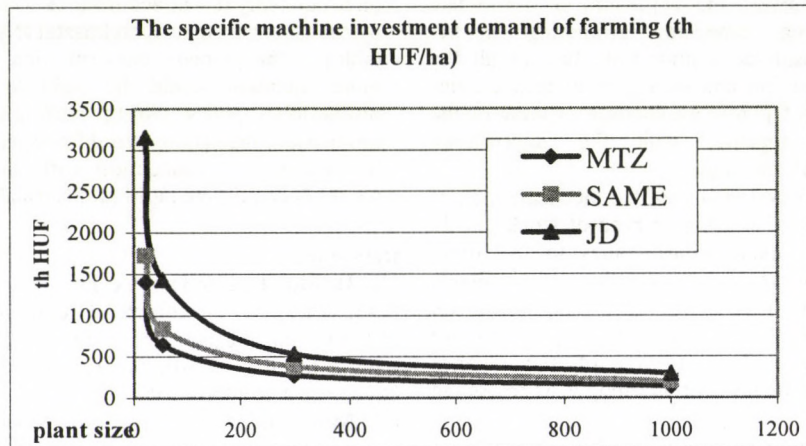
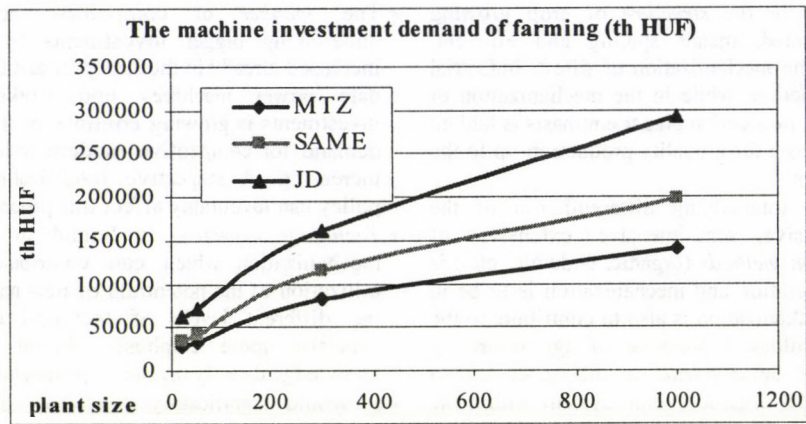

Fig. 1

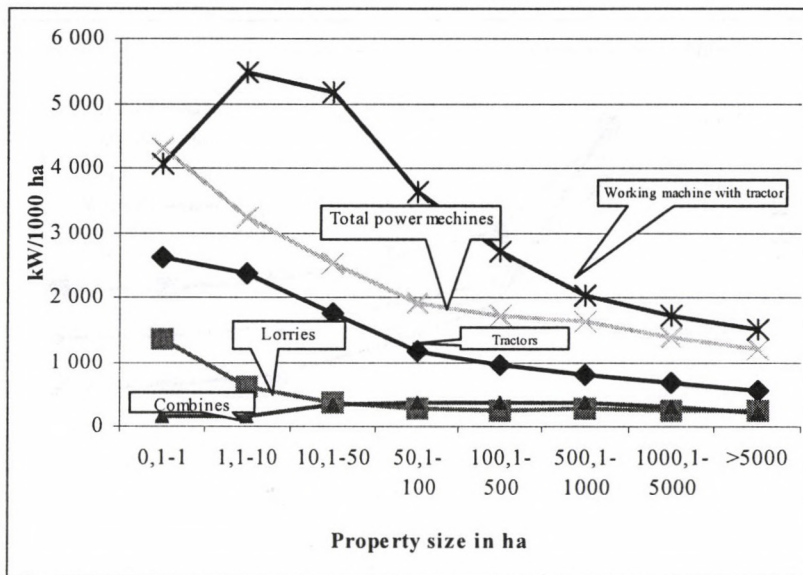

Fig. 2 The changes of machine endowment indexes depending from property size (KSH - ÁMÖ)

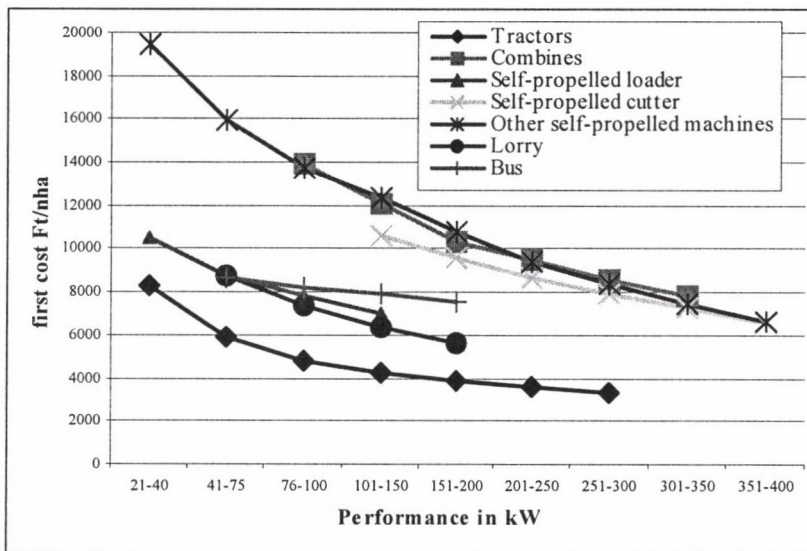

Fig. 3 The first cost of machine utilization related to machine capacity

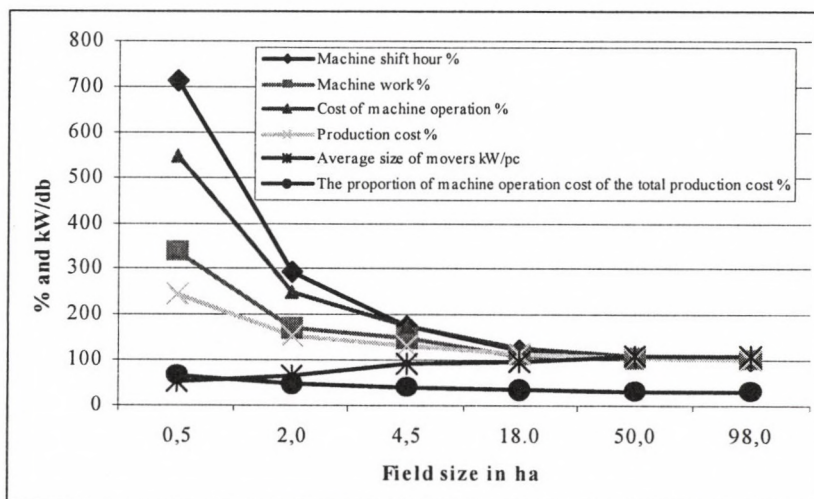

Fig. 4 Changes in attributes of machine operation related to field size

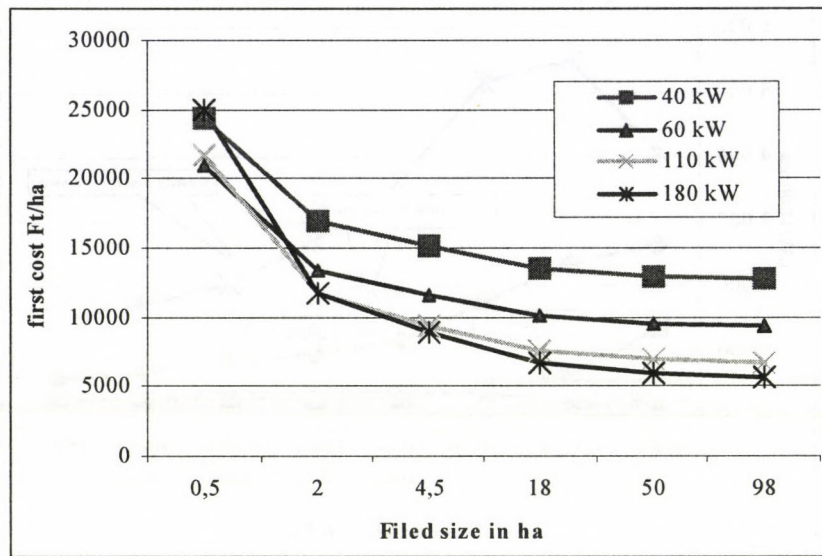

Fig. 5 The first cost of semi-deep tillage related to field size and size of prime mover

## ECONOMIC ANALYSIS OF MECHANIZATION TECHNOLOGY OF FIELD VEGETABLE PRODUCTION

L. Magó – F. Jakovác  
Hungarian Institute of Agricultural Engineering, Gödöllő

### Introduction

In this paper the economic investigation of field vegetable production is introduced by using the production technology of the most important vegetables, onion and tomato as examples.

*Onion* is a very important vegetable that plays a very significant role in human nutrition. Practically onion is produced in every part of Hungary on large, as well as on medium and small farms, on 5-8 thousand hectares altogether. Onion production is very significant in Csongrád, Békés, Bács-Kiskun and Győr-Moson-Sopron counties.

Seed-grown vegetable onion is gradually gaining ground on the traditional onion set production method. In our present days there are good seed-grown species available for farmers. These species can provide good quality products and can be stored well. In addition to that lands can be irrigated well and there are good herbicides available, therefore this production method can be applied safely.

Tomato is one of the most popular vegetables in the world, produced on very large lands. Canning tomato is a very significant vegetable in Hungary as well, traditionally produced on a very large land – 3700-4000 hectares – by transplanting or direct seeding methods.

This paper focuses on introducing the mechanized production technology of seed-grown onion and direct-seeded canning tomato. The technology was worked out by Róna MgSz (agricultural cooperative) in Szabadszállás.

The paper also aims to promote the popularization of the modern technology of field vegetable production by reviewing production technology and providing useful pieces of information on the operational and economic figures of the machines necessary for production (Fenyvesi 2004). [2]

### The introduction of the production technology

The introduction of the machinery for field onion production is shown in **Table 1**. The table includes the name of operations, the applied machine for each operation and the type of the tractor they are mounted on. The table also shows the operational performance of the machine unit (a tractor and a working machine) and the operational performance of the given working machine for the given farming year. It also includes economic data on the investment costs of working machines and tractors, their costs per one operating hour and the costs of operation of the machine unit. (Gockler-Hajdú 2004) [3]

Stubble stripping with a disc harrow is very essential to work the stem remains of the forecrop into the soil and to prevent the field from weeding. Stubble stripping is followed by a semi-deep loosening of the soil and then by ploughing. The nutrient supply of soil includes the transport of suspension and spraying. Then the suspension after spraying has to be worked into the soil by a seed-bed former then the surface of the soil has to be levelled a couple of times. Then the appropriate seed-bed has to be formed. The seeds are sowed by twin-row sowing method. Mechanical weed control by using a cultivator is necessary to kill weeds between the rows at least three times during the vegetation period, while nutrient supply is also indispensable. Chemical weed control (spraying) is also necessary at least seven times during the vegetation period. Irrigation in the vegetation period is also very important in order to increase yields and to improve quality. Linear irrigation systems are applied to irrigate onion fields.

In this technology traditional soil cultivation machines are used for preparing the surface of soil. The ACCORD MINIAIR SUPER pneumatic direct seeder is used for sowing, the LINEAR irrigation system is used for irrigation and a row fertiliser broadcaster is used for fertilising crops.

The ASA-LIFT onion harvester, which tops, lifts and picks up onion in three separate operations, is used for *harvesting onion*. The production technology of onion has already been proved to be effective for years which means that machines can be operated optimally and the end products have excellent quality for export markets.

*The production technology of canning tomato* is also different from that of onion in the type of the applied harvester.

The GUARESI G-89/93 self-propelled tomato harvester – which is equipped with a unit that sorts tomatoes by their colour – is used for harvesting tomato. It lifts, cleans sorts and grades tomatoes in one operation.

### The introduction of the machines of the technology:

The **ACCORD MINIAIR SUPER pneumatic direct seeder** (Figure 1) is used for sowing vegetables that have small seeds (up to 4 mm). Its parts are: a blow-down-exhaust fan mounted on an axis, adjustable press wheels, a drive and sowing units (with seed discs). The shortest distance between the seeding carts can be 120 mm, but tandem carts can also be applied if necessary, then the distance between the twin-rows will be 80 mm. Coulters, which are appropriate for sowing with 65 mm row distance, can also be mounted on the sowing units. Onion is usually sowed with 12 pieces of twin-sowing units. Different seed discs are used for different seeds which means that distance between seeds varies between 20 and 250 mm. Clod sweeps and wheels to compact the soil can be mounted on sowing units in order to achieve better quality sowing.



Fig. 1 ACCORD MINIAIR SUPER pneumatic direct seeder

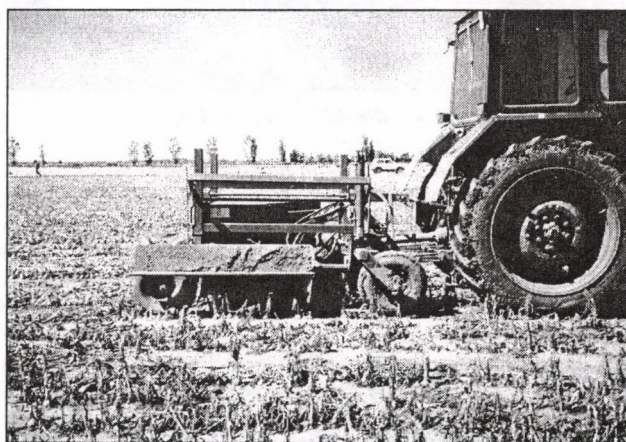

Fig. 2 ASA-LIFT haulm cutter

The *ASA-LIFT haulm cutter* (Figure 2) is a machine with a vertical axis and circular knives. The task of the machine is to chop the green stem of onions and weeds. The three cutting knives are mounted on the axis in a way that they lap each other. The machine takes the cut stems and weeds to the side. The angle between the knives is 45 degrees so they have a suction effect in addition to chopping. Any type of tractor with power higher than 25 kW is appropriate for operating the machine.

The task of the *ASA-LIFT onion lifter* (Figure 3) is to lift onions out of the soil and windrow them after cleaning so that they could dry to the required level. The machine is produced in a suspended form with cardan drive. Its lifting machine is a rectangular axis which lifts the onion in the soil by its circular move under the root of the onion. Then the loosened onion is picked up by a chain grate mounted with rods. Two chain grates clean the onions and destroy clods. They are floated by an alternating star in order to achieve better cleaning. A wing with rods that is behind the second chain windrows the onions. In order to prevent onions from rolling down from the top of the beds a V-shaped slide blade is mounted on the machine which creates a hollow for the onions. The working depth of the machine can be adjusted by the screw lift suspension system of the press wheel.



Fig. 3 ASA-LIFT onion lifter



Fig. 4 ASA-LIFT onion pick-up

The task of the *ASA-LIFT onion pick-up* (Figure 4) is to pick up, clean and put the onions which dried on the surface of the soil for a couple of days in the transport vehicle. In this case a similar rectangular axis is used for lifting the onions. If soil circumstances are favourable the axis can be disassembled from the machine and the chain will work as a lifter itself. A sponge roller that works in front of the chain makes lifting easier by deflecting the onions to the chain. Chain grates clean the onion in this case as well. They are equipped with alternating chain pairs in order to improve cleaning. An elevator with adjustable angle and height takes the onions to the transport vehicle. Hydraulic engines drive the structural parts of the machine

therefore the velocity of chains can be brought in line with each other. A tractor with power of 60 kW is sufficient to operate the machine.

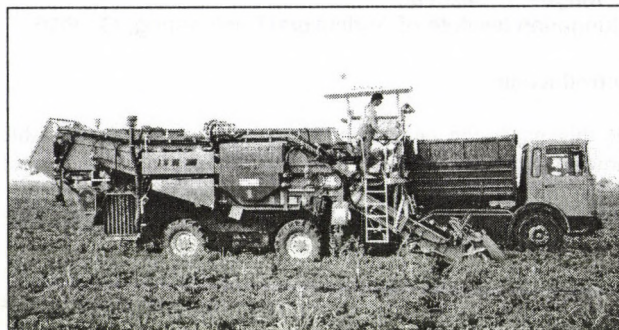

Fig. 5 The GUARESI G-89/93 self-propelled tomato harvester

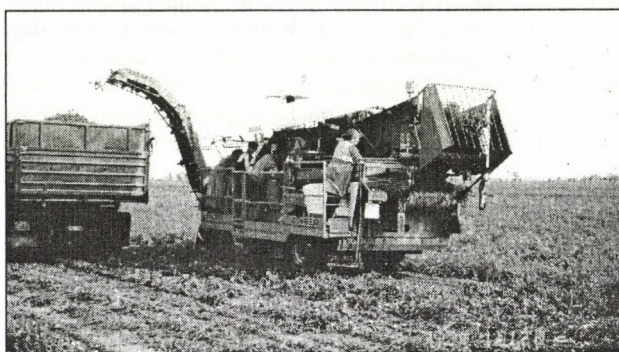

Fig. 6 Filling the transport vehicle with tomatoes

The GUARESI G-89/93 self-propelled harvester (Figure 5 and 6) is the most important machine in the *canning tomato production technology*. It lifts tomatoes, separates them from their stem and sorts them by their colour. It is also appropriate for separating stem remains, clods, and damaged tomatoes, and to take the crop to the transport vehicle which is synchronised with the harvester. The performance of the harvester is 20-25 tons an hour if 90 percent of the tomatoes are red. The unit that sorts the tomatoes by their colour can separate 95 percent of green tomatoes from ripe ones.

The tomato bushes are lifted from the ground by moving rods and then a knives cuts the roots of the crop just under the surface of the soil. There are rollers under the lifter in order to provide better tracking of the ground and more effective lifting. The lifted bush is taken to a shaker with rods which shakes the tomatoes off their stems by its floating and circular move. Then it takes the stems to the stem wing tripper and the tomatoes to the tomato wing tripper. The stems leave the machine and are dropped on the ground. The tomatoes are taken to the lateral belt and then to the unit which sorts them by their colour. After that they are taken to another sorter and then to the synchronised transport vehicle.

The machine does not cause much damage to the tomatoes. Much more damage is caused during transport, so it is very important to take the crop to the processing company in the shortest possible time.

#### The results of the investigations

Table 2 shows the results of the economic investigations of *onion production* on 100 hectares. The time of the machine operation necessary for the cultivation of 100 hectares was determined for machine units. Then the direct operation costs of machine units were determined which can be calculated as direct machine operation costs per operating hour (Table 1) multiplied by the number of operating hours. Other costs of the

machine units were also determined which are affected by the return on fixed and current assets and the fixed costs of farming. The result of the calculations is the costs related to each operation for 100 hectares of land. Adding them the results give the total costs and the specific costs (per hectare) of onion production for 100 hectares.

The results show that the operation costs of working machines for *onion production* are less than half (25.764 EUR) of that of tractors (47.903 EUR), while the total machine operation cost is 73.667 EUR. Its value per hectare is 736 EUR.

It is important to state that the transport of onion during the harvest required a low capacity, only 600 operating hours. It is because of the fact that in this case the crop was transported to the storage of the farm and not to the plant of the processing company which can be even 100 km away from the place of harvest. In that case road transport would be required which is much more costly.

However the machine operation costs of crop transport add up to 30 percent of the total machine operation costs of onion production. It is followed by picking-up (13 percent) and the proportion of other operations to total costs is less than 10 percent, and does not exceed 1 percent in some cases.

The tractors that were taken into account in this research were reliable and expensive ones which means that their investment and operation costs were high. Of course the tasks could be done with machines of appropriate performance but of a lower technical level. In that case the costs of machine operation may be lower than calculated in this paper.

The investment costs of machines used in this *onion production technology* are 601.949 EUR, of which 382.686 EUR is the cost of working machines (64 percent of the total) and 219.263 EUR is the costs of tractors (36 percent of the total). Soil cultivation tasks require a tractor with a power of 140 kW while nutrient supply, plant protection, sowing and harvest require two tractors with a power of 65-70 kW. That results in relatively low investment costs and high tractor efficiency. The total time of machine operation of onion production on 100 hectares is 2.064, of which the tractor with the higher power has a significant part during soil cultivation and harvest, but the operation time of the two smaller tractors is also significant during plant protection and harvest.

The distribution of the costs of operations is very similar to that of machine operation. Harvest has the highest part of the costs (57 percent of the total), followed by soil cultivation tasks (19 percent), then plant protection tasks (10 percent) and then nutrient supply, sowing, and irrigation (3-4 percent).

The *technology of canning tomato production* is different from the technology introduced in **Table 1** in the use of the self-propelled harvester. Another difference is that the crop after the harvest is directly transported to the processing company on road which means extra work and additional costs (see the extension of Table 1).

The operation costs of working machines used in this tomato production technology is 19.876 EUR (15 percent of total machine operation costs) and the operation costs of tractors are 125.772 EUR (85 percent). The total machine operation cost is 145.648 EUR, while its value per hectare is 1456 EUR.

The capacity need of transport during tomato harvest is very high, 2500 operating hours, since in this case crop was directly transported with vehicles of 15 tons of capacity to the processing company which was 80 km away from the place of harvest. Our calculations show that the crop of one hectare requires four turns from transport vehicles. The time of one turn is about 6 hours which means that 4 turns require about 25 hours.

Not surprisingly, 43 percent of the total costs are related to crop transport. It is followed by harvest (25 percent) and the proportion of other operations of the technology is under 4 percent, even under 1 percent in some cases.

The total investment cost of machines in this *canning tomato production technology* is 694.024 EUR of which the cost of working machines is 297.996 EUR (43 percent) and the cost of tractors is 396.027 EUR (57 percent). In this case the investment cost of the self-propelled harvester significantly increases the costs of machines. Despite the fact that machines with low investment and operation costs were applied in this technology for transport tasks, transport costs still remained high. *Canning tomato production* on 100 hectares require 4.698 hours of machine operation of which the transport vehicle works for 2500 hours. The tractor of higher power does not have too many tasks except soil cultivation which means that its operation time is not very high. However tractors of lower power are operated for a much longer period during plant protection and harvest tasks. The operation of the self-propelled harvester is also very significant (500 operating hours). Moreover extra tractor capacity is also required during harvest because it has to draw a trailer synchronised with the harvester to collect the crop because naturally the road transport vehicle is not appropriate for moving slowly beside the harvester. Harvest is the most costs-demanding of all the operations (75 percent of the total operation cost), followed by soil cultivation (10 percent), plant protection (7 percent), and nutrient supply sowing and irrigation (1-2 percent).

### Conclusions and recommendations

The investigations prove that the machine operation costs of field vegetable production are high. In addition to that the annual utilization level of special harvesters is very low and there are few opportunities to increase it. It is because of the fact that vegetables are produced on smaller territory of land and there is low demand for machine work rent.

It is favourable for *onion production* that harvest is implemented with tractor-drawn machines without using expensive self-propelled harvesters. The investment costs of machines mounted to tractors are lower while their utilization and specific operation costs are favourable as well.

87 percent of the total machine operation costs of *onion production* are related to harvest, soil cultivation and plant protection.

The investigations show that the self-propelled tomato harvester completely utilizes its annual operating hour by harvesting 100 hectares of land, which means that its utilization and specific cost is favourable but very cost-demanding because of the large amount of crops.

92.5 percent of the total machine operation costs of *tomato production* are related to harvest, soil cultivation and plant protection.

The costs of crop transport depend on the distance between the place of harvest and the processing company. Transport costs can be as high as production costs.

### Acknowledgements

This paper was supported by the *János Bolyai Research Scholarship* of the *Hungarian Academy of Sciences*

### References

- [1] Dimény I., Fenyvesi L., Hajdú J.: „Piactudatos zöldségtermelés”, MGI Könyvek, No. 3., 2004. 234. p.
- [2] Fenyvesi L.: „A szántóföldi zöldségtermesztés gépesítési technológiájának piactudatos fejlesztése”, Óvári Tudományos Napok, Mosonmagyaróvár, 2004. okt. 7., p.143.
- [3] Gockler L., Hajdú J.: Mezőgazdasági gépek ára és üzemeltetési költsége 2004-ben (The Purchase Price and Running Costs of Agricultural Machines in 2004)”, Mezőgazdasági Gépüzemeltetés 2004. No.1., FVM Mezőgazdasági Gépesítési Intézet. Gödöllő, 2004.

[4] Hajdú J., Horváth S., Jakovác F., Salamon S.: „Hagytermelés, ASA-LIFT hagymabetakarító gépsorral” Értéstitő termeléstehnológiák műszaki és gazdaságossági vizsgálatáról. FVM Mezőgazdasági Gépesítési Intézet, Gödöllő. 2002. 25 p.

[5] Hajdú J., Horváth S., et al.: Konzervparadicsom termelés (GUARESI G-89/93 típusú önjáró paradicsom betakarítógéppel)” Értéstitő termeléstehnológiák műszaki és gazdaságossági vizsgálatáról. FVM Mezőgazdasági Gépesítési Intézet, Gödöllő. 2003. 29 p.

[6] Husti I.: „Gondolatok és teendők a magyar mezőgazdaság gépésítésében” Gazdálkodás. Vol. XLVI. 2002. No. 5. p.: 26-32.

[7] Magó L., Hajdú J.: „Utilization Cost Structure of Optimal Power Machinery Fleets According to the Farm Sizes”, Proceedings of the 31<sup>th</sup> International Symposium “Actual Tasks on Agricultural Engineering”, Opatija, Croatia, 24-28. February 2003. Proc. p. 143-150.

[8] Takácsné György K.: A TЭСZ-ek szerepe a kertészeti termékek előállításával foglalkozó vállalkozások finanszírozásában. In VISION 2000 - Az intézményrendszer helyzete és fejlesztése az agrárgazdaságban, az EU csatlakozás tükrében. Konferencia kiadvány I. kötet. 1999. Gödöllő. 212-221 p.

Table 1 The economic figures of the operations of onion production

Name of operation	Machines in the technology		Operational performance (ha/h)	Operating hours (h/year)	Costs of machines		Direct machine operation costs		
	working machines	tractors			work. mach.	trac.	work. mach.	trac.	total
Stubble stripping	KÜHNE KNT-770-7,2	NH G 190 DT	3,5	500	18788	106910	9,7	26,6	36
Semi-deep loosening	KÜHNE KML-700-3 with 3 knives	NH G 190 DT	0,8	240	5349	106910	4,2	26,6	31
Ploughing	KUHN VARIMASTER 151 5T	NH G 190 DT	1	600	19341	106910	6,8	26,6	33
Levelling of the surface	S-2 H/M	NH G 190 DT	4,8	200	7306	106910	7,1	26,6	34
Suspension transport	DETK-115	NH TS 90 DT	6	600	6667	54902	4,3	14,5	19
Suspension spraying	HUNIPER HDE 3000MT/18RQ	NH TS 100 DT	6	300	32714	57451	34,9	15,9	51
Working in the suspension	UNIMAT 6,6	NH G 190 DT	4,1	400	8384	106910	9,5	26,6	36
Levelling of the surface	NSH-3 430/550	NH TS 90 DT	3	900	1545	54902	1,4	14,5	16
Forming the seed-bed	RAU Terramax	NH G 190 DT	4,1	400	26114	106910	13,7	26,6	40
Sowing in twin rows	ACCORD MINIAIR 12 twin-row	NH TS 100 DT	2,8	200	47059	57451	37,6	15,9	54
Cultivating (3 times)	ZSMK 12-row	NH TS 90 DT	2,4	300	3902	54902	5,0	14,5	20
Solid suspension transport	MBP 6,5R	NH TS 100 DT	4	900	5898	57451	2,0	15,9	18
Solid suspension spraying	RCW 5	NH TS 90 DT	4	400	8000	54902	5,9	14,5	20
Spray transport (7 times)	DETK-115	NH TS 100 DT	4,8	600	6667	57451	4,3	15,9	20
Spraying (7 times)	GAMBETTI GB EXP 1500/16	NH TS 90 DT	4,8	300	15918	54902	8,9	14,5	23
Irrigation	VALMANT linear irrigation system		1	1.100	96078	0	16,5	0,0	16
Haulm cutting	OT 1500 ASA LIFT	NH TS 90 DT	0,8	300	14118	54902	14,5	14,5	29
Lifting, windrowing	L 150 ASA LIFT	NH TS 90 DT	0,6	200	12549	54902	13,7	14,5	28
Picking-up, put in the vehicle	SL 135E ASA LIFT	NH TS 100 DT	0,6	200	47059	57451	26,7	15,9	43
Crop transport	MBP 6,5R 2 db	NH G 190 DT		900	11796	106910	4,1	26,6	31
The economic figures of the operations of the harvest of canning tomato									
Harvest		GUAR. G-89/93	0,2	500		143706		55,0	55
Crop transport	HL 92.02 (road)	IFA L 60 1218 DSK		2.000	7388	33059	2,5	19,5	22

Table 2 The economic figures of the operations of onion production on 100 hectares

Name of operation	Machine operation (h)	Direct operation costs of the machine unit (EUR)	Other costs of the operation of the machine unit (EUR)	Total machine operation costs		Operation costs (EUR)
				working machines	tractors	
				(EUR)		
Stubble stripping	28	1016	205	341	880	1221
Semi-deep loosening	125	3844	778	690	3932	4622
Ploughing	100	3336	688	879	3145	4024
Levelling of the surface	20	673	141	186	628	814
Suspension transport	16	301	62	82	281	363
Suspension spraying	16	812	172	679	305	984
Working in the suspension	24	865	156	266	755	1021
Levelling of the surface	66	1047	216	101	1162	1263
Forming the seed-bed	24	967	214	426	755	1181
Sowing in twin rows	35	1872	598	1803	667	2470
Cultivating (3 times)	123	2398	500	732	2166	2898
Solid suspension transport	25	447	91	61	477	538
Solid suspension spraying	25	510	111	182	439	621
Spray transport (7 times)	140	2826	565	718	2673	3391
Spraying (7 times)	140	3283	877	1694	2466	4160
Irrigation	100	1647	532	2179		2179
Haulm cutting	125	3626	793	2218	2201	4419
Lifting, windrowing	166	4686	1170	2933	2923	5856
Picking-up, put in the vehicle	166	7062	2716	6609	3169	9778
Crop transport	600	18394	3470	2985	18879	21864
<b>Total</b>	<b>2064</b>	<b>59.612</b>	<b>14.055</b>	<b>25.764</b>	<b>47.903</b>	<b>73.667</b>
<i>Per one hectare (EUR/ha)</i>						
The economic figures of the operations of the harvest of canning tomato produced on 100 hectares						
Harvest	500	27515	9148		36663	36663
Crop transport	2.500	54989	1608	7035	55741	62776
<b>Total</b>	<b>4.698</b>	<b>120.277</b>	<b>25.371</b>	<b>19.876</b>	<b>125.772</b>	<b>145.648</b>
<i>Per one hectare (EUR/ha)</i>						

## EFFECT OF NUTRIENT SUPPLY ON THE VALUE OF FIELDS IN HUNGARY

Z. Peszeki – Zs. Szentpétery – I. Kovács  
Szent István University, Gödöllő

### Introduction

Analyzing Hungary's capabilities we can agree, that our arable stock, which is available in limited amount and cannot be enlarged much more, plays more and more important role of our resources.

From the whole area of the country (9 303 400 hectare) the agricultural land was 5 million 865 thousand hectare in the 31st May 2003. The size of the arable lands -which contains the area of the forests, reeds, fish ponds too apart from the agricultural lands- is 7 million 734 thousand hectare. The size of the plough-land, which determines the agricultural production, is almost 4516 thousand hectare, but the forests' (1775 thousand hectare) and green's (1062 thousand hectare) ratio is considerable too.

There are two things which change basically in the hungarian land market by reason of the EU membership. The first well-known change is the entering of land based support. The second indirect change will be the interest of the capital of EU, because the capital of EU wants to achieve the domestic market contribution in the connected country's market too, and looks for the promising opportunities.

The EU's land cultivating enterprises and private persons (not the owners) owing agricultural land based support is an income complement support, which encourages the economic activities. The amount of it is 70.000 HUF/ha/year now in the EU. From this we get 25% (17.500 HUF) in 2004, and it increases annually. The Government may expand this part additionally with 30% (21.000 HUF). In 2004 the initial amount of the support was 38.500 HUF/ha/year. To compare with 2003: in that year the land based support was 7.000 HUF/ha/year in Hungary, and nowadays 30-40 thousand HUF means a good profit in a year per hectare. So the income can double.

The expectable extra income takes the interest to the producers in enlarging the actual land. Prospectively this will double the actual 10-15.000 HUF/ha/year rental fees, which despite of the increasing means just 70-90 €, while in the EU the average rental fees are between 150-350 €. The doubling rental fee, which is tax-free in case of real agreement longer than 5 year period, can cause quickly the doubling of the actual prices of the land.

But who is allowed to buy land in Hungary? For the future the buying is allowed only for hungarian private persons to 300 hectare (ab. 120-140 million HUF). Neither foreigners are not allowed to buy land until 2011 and nor native enterprises yet.

It can be established, that the difference between the land prices in EU and in Hungary is five-tenfold average and the EU's land prices per hectare is in the zone of 2-5 million HUF.

### Hungary's land worth in 2004

Cultivate branch	Total area [thousand ha]	Minimum price [thousand HUF/ ha]	Maximum price [thousand HUF/ ha]	Average price [thousand HUF/ ha]	Total estimated worth [billion HUF]
Plough-land	4515,5	160	1800	450	2 032
Kitchen-garden	96,0	350	1700	800	77
Orchard	98,3	450	7000	1600	157
Grapery	93,3	400	8000	1500	140
Green	1061,6	70	600	180	191
Agricultural area	5864,7	70	8000	443	2597
Forest	1775,1	120	1900	400	710
Reed, fish pond	93,9	80	2100	450	42
Arable	7733,6	70	8000	433	3349
Withdraw from cultivation (midland too)	1569,8	60	900 000	8400	13186
Total	9303.4	60	900 000	1777	16535

### Land market prices in EU states in 1999

Country	Value (thousand HUF/ha)
Luxemburg	12.898
The Netherlands	7.621
Spain	3.524
Italy	3.352
Belgium	2.908
Denmark	2.539
Germany	2.163
England	2.463
France	838
Finland	829
Sweden	423
Hungary	150

Source: *The agricultural situation in the European Union 2000 Report.*

### Methods

To evaluate the arable the following methods can be used principally (based on the NFA's recommendation):

1. evaluation based on market data comparison,
2. evaluation based on yield,
3. evaluation based on yield, counted with consideration of direct land base support a (only in case of arable),
4. evaluation of the forests, according to the simplified method in the annex of the Hungarian Government decision nr. 2. (a 254/2002. (XII. 13.) or the detailed method of West Hungarian University.

From the aboves two methods are accepted to evaluate the arable in Hungary nowadays: the market data comparison and the yield method based on average crop which depends on the land's gold corona value:

**Ad 1.** The evaluation based on market data comparison is made by extend and compare the realized, concrete and well-known cases' prices on the analyzed case. Through the evaluation we analyze the properties which have been recently sold or offered on market and compare it with the object of the evaluation. Meanwhile we consider the elements which determinate the market.

**Ad 2.** The evaluation based on yield deduces the object's value from the difference of the object's future benefits and costs which appear while we capture them. The evaluation based on yield regard to the arable was made according to the 54/1997. (VIII.1.) Ministry of Agricultural and Rural Development (FVM) decision. The plantation's value was determined with cost-based calculation (consequence of lack of yield data).

## Results

We show the new examination results of 2004 based on own and the Hungarian National Landfoundation's (MNF) some expert's results in the following chart. Actually we have used basically two examination method to the evaluation of arable: the average yield method based on average crop which depends on the land's gold corona value and the market data comparison method.

We have estimated the land prices and the whole land worth for the cultivate branches based on considerable numerous arable evaluation with both methods.

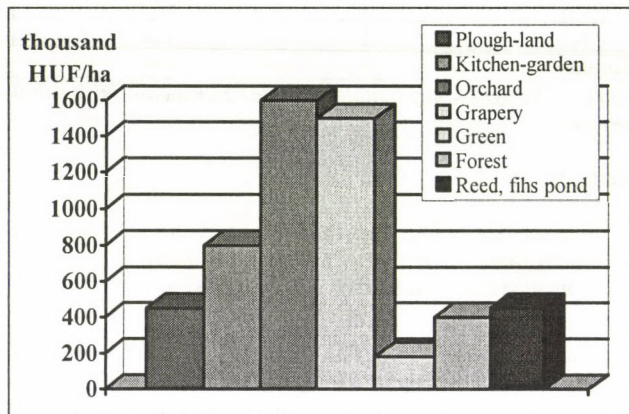

Fig. 1 Arable average-prices for the cultivate branches

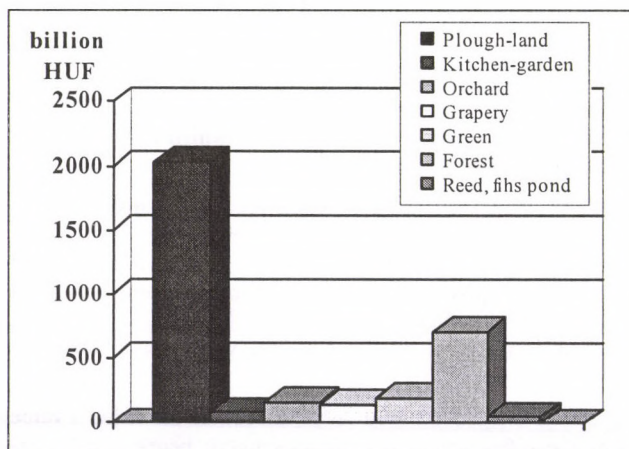

Fig. 2 Estimated worth of Hungary's land worth for the cultivate branches

## Conclusions

1. Nor the NFA neither the FVM hasn't got data about the arable's worth. That's because our conclusions for the worth value based on our and worth evaluator experts' hundreds of evaluations, which were made in the lasts years mostly with two kind of evaluation method: the average yield method based on average crop which depends on the land's gold corona value and the market data method.
2. Based on the examinations we can conclude that the worth evaluator experts consider very much (18-20) different factors during the evaluation, but they value the real quality of the land just through the gold corona classification. This means that the nutrient supply and the organic material supply of the arable isn't be considered despite of they are affect on the arable's value too.
3. In Hungary the value of 1 ha arable of average quality can be estimated as 450 000 HUF, but the values are spreading extraordinarily, tenfold or in extraordinary conditions either more thousand fold differences can occur.
4. Based on the completed examinations and evaluations we can conclude that Hungary's recently arable worth is 3349 billion HUF.
5. In Hungary the price of the arable is extra dynamically rise and in the next 3 years they can double.
6. The hungarian land prices don't reach even the 20% of the prices of EU.
7. Result from all these that in the next years the arable investments will bring the highest yield.

## References

- [1] **Peszkei Z.** - Kovács I.: A mezőgazdasági eszközállomány ökonómiai vizsgálata.
- [2] MTA -AMB Tanácskozás, Gödöllő, 2001. I. 23 - 24.
- [3] **Peszkei Z.** - Kovács I.: A mezőgazdasági gép- és épületállomány vagyonértékelésének módszerei.
- [4] MTA - AMB Tanácskozás, Gödöllő, 2001. I. 23 - 24.
- [5] **Peszkei Z.:** A mezőgazdasági eszközállomány ökonómiai vizsgálata.
- [6] Mezőgazdasági Technika. 2000. 12. szám.
- [7] **Peszkei Z.:** A magyar mezőgazdaság technikai erőforrása-inak vizsgálata a 90-es években.
- [8] Doktori (Ph.D) értekezés SZIE Gödöllő, 2001.
- [9] **Peszkei Z.** - Kovács I.: A termőföld értéke és értékelése Magyarországon 2004-ben.
- [10] MTA -AMB Tanácskozás, Gödöllő, 2005. I. 18-19.

## THE ROLE OF EXTENSION IN THE TECHNICAL IMPROVEMENT OF AGRICULTURAL ENTERPRISES

K. Tóth – J. Bárczi – Cs. Fogarassy  
Szent István University, Gödöllő

### Methodology

The research was conducted in three economic levels of different regions: in the Central Hungarian Region, in the Northern Hungarian Region and in the North Plains. In line with the purposes of the research, we drew a parallel between the services offered by the advisers and the services demanded by the farmers, moreover, we appraised the regional relations of the farm advisory system. In the course of the research, two methods of getting information for the opinion of target groups were appraised:

- stimulating and combining ideas with Osborne's brainstorming method;
- structural, systematic methods (interview, questionnaire).

According to the criterion set for the target group of farmers, they had to be in contact with a one organisation of professional advisers, they took on the active contribution to brainstorming, and filled in a questionnaire of 37 points. The research also covered two extension groups to be present in the Hungarian structure of advisory system: registered advisers in the Hungarian Register run by the Ministry of Agriculture and Rural Development (MARD), and advisers connected to enterprises.

### Conclusions and proposals

At the moment, 8 sections prevail in Hungary, completely separated from each other (Figure 1). First section created in 1994 and reorganised in 1998 was the **village manager network**. Although, village managers cannot be regarded as classical advisers, they provide valuable information to the efficient production for farmers.

Second sector of the advisory system is the Register of Advisors recorded in MARD. Passing into the Register, farmers have to apply for admission. Main data of those advisers are included who possess the appropriate qualification in university education, experience, and have the certification of moral, moreover, they are not agents and not involved in activities of commerce connected to the agro economics. The distribution of the sectors engaged by advisers is shown in Table 1.

Third sector mentioned in the advisory system is the Network of Hungarian Agricultural Chamber. In an agreement made with the MARD, the Hungarian Agricultural Chamber took on providing extension to the farmers free of charge. Although, the scope of activities in the case of village managers and advisers in chambers is not the same, but both groups provide official administration to the ministry in charge. Division of the tasks between the two organisations in practice is not clear enough. In the course of the research it turned out that advisers in chambers cannot be regarded as members of the classical extension neither in their names, nor in their tasks.

Fourth sector of the system is connected to the extension done in **Regional Advisory Centres**. The main task of these centres is to contribute to improve and spread knowledge in connection with the agriculture. By including experts from the agricultural universities, these centres take on improving tasks of farmers' knowledge in a given region. These centres play a huge role in coordinating extension programmes grouped free of charge.

Fifth sector of the system is connected to **Professional Centres of Advisers**. The appointed centres do their specific activities throughout the whole country. They fulfil their tasks by intellectualise the work done by research institutes.

Sixth sector of the system can be connected to **model farms**. To develop the network of model farms can provide a great help to improve the professional knowledge of farmers.

Seventh sector of the system is protecting interests, which is done by **civil organisations of extension**.

Eighth sector of the system is the advisory activity connected to **enterprises**. This kind of extension is not connected directly to the extension structure supported by the MARD. Advisers belonging to the given enterprise motivate their customers to apply their own products and services. Applying efficient marketing methodology, they reach farmer target group directly. Having resort to this kind of extension, farmers are not allowed to get support from the state. Contrary to this, more and more enterprises like these run in Hungary. These enterprises engage advisers according to their specific areas, sizes and income. In case of commerce, they engage regional agents. These advisers are well educated in their specific area and in methodology as well, who are aware of the farmers' demands.

**Extension supported by the state can be asked according to the income of agricultural enterprises.** Farmers having less than 1 million forint income can take part in grouped extension free of charge. Coordinating the network of village managers from the regional Agricultural Offices are the coordinators of these programmes, such as Hungarian Agricultural Chamber and Regional Extension Centres of Agricultural Universities or Colleges (Bárczi – Kozári – Tóth, 2000). Those Registered entrepreneurs which have an income of more than 3 million forint but do not exceed 50 million forint and they produce according to the demands on MARD regulations of "Good Agricultural and Environmental Stage" and "Good Agricultural Practice", can sign an advisory contract with Registered Advisers recorded by MARD.

The number of Registered advisers is moving between 520 and 630 according to the state of measures. The number of Registered advisers is declining from year to year. One reason for this is that the support system does not provide the opportunity of extension done in full time yet.

Technological extension has a main role in planning and organising work processes of small scale farms, improving the efficiency of labour and reducing the costs of production (Tóth 1995). According to Table 1, it can be stated that the rate of advisers who can interpret technical innovations, do not reach 5%. This rate is low, which causes problems in financial sources for those farmers primarily, who cannot allow themselves to ask for advisory services in enterprises.

We examined, which issues of extension services are demanded by farmers participated in the course of the research; moreover, we also took a research on the link between the number of professional areas and the educational level of farmers. Areas of extension recognised by the examined target groups in regional breakdown is shown in Table 2.

The distributions of professional areas in different regions show significant digression. More than 50% of the farmers examined in the Central Region of Hungary showed the demand of professional extension for technical innovation. In the other two regions examined, the rate of farmers can also be regarded significant, who recognised the importance of technical innovation and expertise.

In the course of regional examinations it turned out that the rate of supported advisers in technical expertise is the lowest (0,8%), which is 2,73% in the Northern Region of Hungary and 6, 06% in the North Plains.

We found that Registered advisers cannot meet the demands of farmers in the area of machinery. For this reason, there is a need for integrating additional sectors of the extension. In providing extensional service, the role of agricultural colleges and universities, model farms and professional extension centres is over valuating, as the tasks of advisors in enterprises can be required by large scale farms with higher profit. Task distribution between the stages of extension system is not efficient, which significantly reduces the level of professional knowledge of the agricultural enterprises.

Table 1 Distribution of the sectors engaged by advisers in 2004

Specialisation	Distribution of coherent specialisation	
	(capita)	(%)
Plant growth	261	21.46
Agraeconomy, farming	199	16.37
Plant protection	160	13.16
Animal breed	144	11.84
Horticulture	133	10.98
Environmental economy	79	6.50
<b>Engineering technology</b>	<b>51</b>	<b>4.19</b>
Melioration, water management	28	2.30
Silviculture	20	1.64
Processing of animal products	20	1.64
Agro tourism	19	1.56
Game management	18	1.48
Veterinary science	15	1.23
Processing of Greenerxy and Fruits	13	1.07
Processing of plant productivity	12	0.99
Nutrition management, soil protection	10	0.82
Drink production	7	0.58
Ecological farming	7	0.58
Rural development	6	0.49
Ficheries	4	0.33
Land management	4	0.33
Logfistics	3	0.25
Processing of Tobacco	2	0.16
Landscape protecting and horticultural architecture	1	0.08
<b>Summarizing:</b>		<b>100.00</b>

Source: Institute of Course and Extension, Budapest, 2004. (processed by K. Tóth in 2005)

Table 2 Areas of extension recognised by the examined target groups in regional breakdown

Extensional fields demanded	Regions		
	Central Hungary (%)	Northern Hungary (%)	North Plains (%)
Plant growth	84.3	55.9	84.4
Horticulture	33.3	20.6	65.6
Viticulture	17.6	23.5	6.3
Animal feed	7.8	17.6	6.3
Plant protection	7.8	2.9	6.3
Animal breeding	11.8	26.5	12.5
Plant protection	74.5	47.1	68.8
Silviculture	9.8	2.9	28.1
<b>Machinery, engineering technology</b>	<b>59.2</b>	<b>35.3</b>	<b>18.8</b>
Organic production	11.8	14.7	12.5
Irrigation	25.5	14.7	18.8
Village hospitality	-	11.8	-
Organisation of new type of co-operatives	29.4	14.7	12.5
Economic enterprises	19.6	17.6	12.5
Finance, taxation	37.3	29.4	21.9
Application activity	27.5	44.1	18.8
Product processing	13.7	11.8	9.4
Other	5.9	2.9	-

Source: K. Tóth, 2005-04-05

In the course of the research, we examined if the education of the agricultural enterprises influences the pass-through relationship with advisers. The results are shown in Table 3. Farmers with elementary education primarily demanded extension services closely related to their activities. From the 20

areas obtained, they could only require six areas of extensional help. This background is due to the low level of education, which can only be compensated if there is an active interpretation medium, and extra information reaches agricultural entrepreneurs.

Table 3 Connections between education and the relationship developed with the adviser

Specialisations of extension	Education		
	Elementary (%)	High school (%)	University (%)
Plant growth	75.0	80.0	71.9
Horticulture	87.5	32.0	38.6
Viticulture	25.0	18.0	14.0
Animal feeding	not dem.	12.0	8.8
Grass management	not dem.	10.0	3.5
Animal growth	not dem.	18.0	15.8
Plant protection	50.0	74.0	59.6
Silviculture	37.5	8.0	14.0
<b>Machinery, engineering technology</b>	<b>not dem.</b>	<b>42.0</b>	<b>42.0</b>
Organic farming	12.5	8.0	17.5
Irrigation	not dem.	20.0	24.6
Game management	not dem.	4.0	3.5
Village hospitality	not dem.	4.0	3.5
Organisation of new type of co-operatives	not dem.	16.0	28.1
Economic enterprises	not dem.	16.0	21.1
Finance, taxation	not dem.	24.0	40.4
Application activity	not dem.	24.0	40.4
Product processing	not dem.	14.0	10.5
Other (image engineering)	not dem.	not dem.	7.0
Ficheries	not dem.	not dem.	not dem.

Source: K. Tóth, 2005

Entrepreneurs with higher and university education have received extensional service in almost every areas offered by the Ministry of Agriculture and Rural Development. This fact shows that in the case of the target group examined in the research, the higher the entrepreneurs' level of education is, the more likely that they recognise the opportunities occurred in innovation, and the more likely they demand the relationship with the adviser.

### Summary

Accession to the European Union started complex economic and social processes. In the altered situation of eco-politics, knowledge that influences the economic competition of the countries tends to be evaluated gradually. In this atmosphere, significant sacrifices have to be made in the area of research and development and extension (Husti I. 1998). We have to take over those experts who are able to interpret the technical innovations needed for the farmers, to spread and cost efficient production among the Hungarian farmers. Within the reform and improvement of extension system, teaching method is necessary not only for developing the competitiveness of Hungarian agricultural entrepreneurs, but also for meeting the requirements of the Common Agricultural Policy. The European Union defined the obligatory running of extension systems defined in the decrees of 1782/2003/EG and 1783/2003/EG as the service of "Farm Advisory System". Farmers can run enterprises effectively if they improve their present level of knowledge, but Hungarian State also has to contribute to the support of extension services. Hungarian farmers are in the change of technology transfer. In the course of mechanic improvements, more and more support

from the state and from the EU is required. For the adequate use of natural resources, more Registered advisers in the machinery innovation have to be employed. These experts have the adequate knowledge to help realising the profit and other factors of enterprises.

*Quality and accessibility of services offered by the advisers have to be improved by all means. The role of extension in the universities and colleges has to be emphasized. Universities and colleges have the adequate intellectual and infrastructural source of information that can be used in the professional and methodological areas of extension courses. Using these opportunities in extension is urgent, as because within the regulation of EU from 2007 on, any Registered adviser of the European Union is entitled to offer his or her services. As an effect of this regulation, advisers from abroad are expected to appear in the Hungarian market, with which Hungarian advisers in their present preparation are not able to compete.*

#### Preferences

- [1] Dimény I. – Hajós L. – Szűcs I. (2003): *A Magyar Tudományos Akadémia Agrártudományok Osztálya Agrár- közgazdasági Bizottságának rendkívüli kibővített üléséről Gödöllő: Emlékeztető Kéziratok*, 34 p.
- [2] Horn P. (2002): *Agár-felsőoktatás és kutatás stratégiai kérdései nemzetközi trendek összefüggésében. Gazdálkodás XLVI. Évfolyam 2002. 1. szám 1-7 p.*
- [3] Husti I. (1998): *Gondolatok a hazai agrár innovációról. Gazdálkodás XLII. Évfolyam 1998. 1. szám 23-33 p.*
- [4] Kozári J (2003): *A mezőgazdasági szaktanácsadás finanszírozása a nyugat-európai országokban. Gazdálkodás XLVII. Évfolyam 2003. 5. számú különnkiadása 65-70 p.*
- [5] Gépi bérvállalkozók könyve: (Szerk.: Tóth L. 1995) Gödöllő: MGBSZ - Mezőgazda Kiadó ISBN: 963 8439 66 1. 339 p.
- [6] Tóth K. (2005): *Az agrár-szaktanácsadás szerepe a mezőgazdasági ismereti rendszerben, fejlesztésének lehetőségei Magyarországon c. Doktori értekezés.*

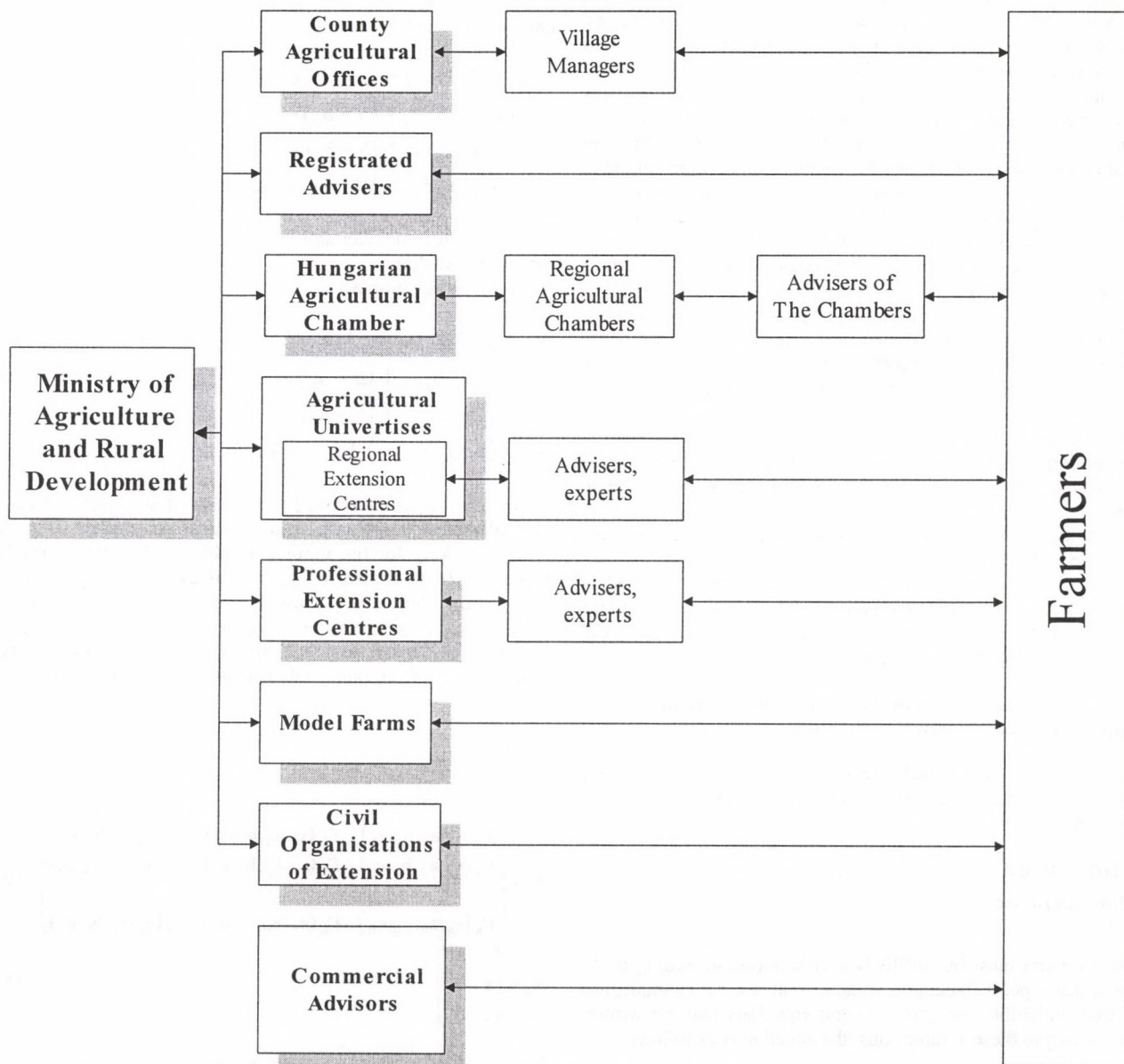

Fig. 1 The structure of agricultural extension in Hungary (Source: K. Tóth, 2005)

## EXPERIMENTAL DEFINITION OF THE PRIMARY FORCE OF STUMP

E. Horváth-Szováti – I. Czupy  
University of West Hungary, Sopron

### Results of measurement

Extraction of the stumps remaining in soil is one of the forest operations, which requires tremendous energy. Under the cut surface there is a huge mass, and extensive root system, and there is a varying compactness of the soil, which means that the power required can be as much as 100.000 – 600.000 N according to Szepesi (1966).

Voronyin (1967) analysed the factors, which determined the power, which will be required, but he did not make a mathematical correlation.

Experiments have been carried out to reduce primary input. In the Great Hungarian Lowland, where there are really enormous areas where forest machinery is required to implement that kind of particular operation, stump extraction is done by special, hydraulic driven caterpillars equipped with sophisticated grabbing devices. During operation of the equipment, different measurements are carried out so as to verify the suitable power supply. The experiments are designed to carry out the measurements with different soils and different tree species. Meanwhile the time requirement is also taken into serious consideration. In the course of the evaluation procedure of our findings, a widely applicable method of parameter estimation - supported by regression-estimation - is shown. According to our findings, the extracting power required in the vertical direction mainly depends on the type of the soil. The soil types in the in the Kiskunsag Region are only a little different from each other. That is why it has not been displayed as a variable function when correlations were articulated.

To make these measurements, the species, which are the most common on the Great Hungarian Lowland such as Scotch pine, acacia, and willow. There is the biggest demand to remove stumps of these species. A measuring device was connected to the hydraulic system of the stump-removing machine; pressure values were measured and recorded during the extraction. The vertical extracting power was defined using geometrical dimensions of the machine and its mechanical characteristics. According to our experimental results, the largest stump, which can be extracted with grabbing technology, has a diameter of 40 cm.

If a stump has a larger diameter, more grabbing is required and the side roots must be cut.

Based on the data and the results we collected, we tried to define the correlation between the diameter of the stump and the extracting power, on sandy soil and on soils with 20% soil moisture (forest site water capacity)

### Function of the extracting-power and stump-diameter to be applied as a mathematical procedure

According to the logical aspects of writing the regressive function of the extracting power and stump diameter, for example,

$$f(0) = 0 \text{ and } \lim_{x \rightarrow +\infty} f(x) = +\infty$$

these criteria must be fulfilled). Furthermore, according to the statistical aspects (lacking a suitable analysis, for example, and F trial, reliability analysis), several equations may be written. According to these assumptions, the equation is as follows:

$$f(x) = a \cdot (x^b + e^{c \cdot x} - 1), \quad (1)$$

Where:

- x stump diameter in cm;
- f(x) required extracting power in N;
- a, b, c unknown parameters which must be defined.

The function matches the results of the measurements in the most efficient way if the measured values and the values calculated according to the regressive functions to define the required extracting power (principle of the smallest squares), there is the least possible difference. The first function contains two unknown parameters and cannot be linearized. That is why this equation cannot be solved by normal simultaneous equations, and approximation cannot be applied either. Such an approximation procedure is, for example, the iteration method based on the Taylor line drawing. It means that function (1) is approximated in a linear way when the Taylor line drawing is applied. (A function can only be written with the application of linear approximation if it is in the Taylor line  $\epsilon$  a remainder is reduced to zero. This criterion is fulfilled only if the second range, mixed partial derivatives are equal. Function (1) met this requirement.)

*The first step of iteration:* Estimation of the unknown values:  $a_0$ ,  $b_0$  and  $c_0$ . It is followed by a Taylor line drawing.  $f(x_i, a, b, c)$  a three variable function ( $x_i, a_0, b_0, c_0$ ). The linear parts are around this place:

$$f(x_i, a, b, c) = f(x_i, a_0, b_0, c_0) + f'_a(x_i, a_0, b_0, c_0) \cdot (a - a_0) + f'_b(x_i, a_0, b_0, c_0) \cdot (b - b_0) + f'_c(x_i, a_0, b_0, c_0) \cdot (c - c_0) + \epsilon, \quad (2)$$

where  $\epsilon$  is the remainder and  $i=1,2,\dots,n$  (the serial number of the measuring results).

Re-write the equation as:

$$\hat{y}_i = f(x_i, a, b, c) - f(x_i, a_0, b_0, c_0) = f'_a(x_i, a_0, b_0, c_0) \cdot (a - a_0) + f'_b(x_i, a_0, b_0, c_0) \cdot (b - b_0) + f'_c(x_i, a_0, b_0, c_0) \cdot (c - c_0) + \epsilon. \quad (3)$$

This expression is substituted in the total of the squares, which was calculated by applying the principle of the smallest squares. We are looking for the minimum value of the three variable functions. To minimize the square values the a, b and c first rank partial derivatives must be reduced to zero (normal equations). Let us introduce (4)-(6) matrix algebraic signs, where the 0 index marks the starting vectors belonging to the estimated parameter values referring to matrix values as well.

$$\bar{y}_0 = \begin{pmatrix} \hat{y}_{1_0} \\ \hat{y}_{2_0} \\ \vdots \\ \hat{y}_{n_0} \end{pmatrix}, \quad (4)$$

$$Z_0 = \begin{pmatrix} f'_a(x_{1_0}, a_0, b_0, c_0) & f'_b(x_{1_0}, a_0, b_0, c_0) & f'_c(x_{1_0}, a_0, b_0, c_0) \\ f'_a(x_{2_0}, a_0, b_0, c_0) & f'_b(x_{2_0}, a_0, b_0, c_0) & f'_c(x_{2_0}, a_0, b_0, c_0) \\ \vdots & \vdots & \vdots \\ f'_a(x_{n_0}, a_0, b_0, c_0) & f'_b(x_{n_0}, a_0, b_0, c_0) & f'_c(x_{n_0}, a_0, b_0, c_0) \end{pmatrix}, \quad (5)$$

$$\bar{x}_0 = \begin{pmatrix} a - a_0 \\ b - b_0 \\ c - c_0 \end{pmatrix}. \quad (6)$$

These normal equations can also be written by applying matrix equations (7), in which  $Z^T$  is transposed to a Z matrix.

$$Z_0^T \cdot \bar{y}_0 = Z_0^T \cdot Z_0 \cdot \bar{x}_0. \quad (7)$$

From this  $Z_0^T \cdot Z_0$  matrix inverse should be multiplied from the left. The difference between the real value and the starting value can be estimated in the following way:

$$\bar{x}_0 = (Z_0^T \cdot Z_0)^{-1} \cdot Z_0^T \cdot \bar{y}_0, \quad (8)$$

where the T matrix is transposed, a (-1) exponent marks the matrix inverse. The coordinates of the resulting  $\bar{x}_0$  vector can be modified with the starting parameter values, and it will result in a more accurate  $a_1$ ,  $b_1$  and  $c_1$  new values.

In the second step of iteration, the procedure is repeated according to the new starting values. (All the vectors and matrixes are shown with subscript 1.)

$$\bar{x}_1 = (Z_1^T \cdot Z_1)^{-1} \cdot Z_1^T \cdot \bar{y}_1. \quad (9)$$

The starting values of the suitable parameters of  $\bar{x}_1$  vector are to be modified again. It will result in more accurate and new values for  $a_2$ ,  $b_2$  and  $c_2$ . The iteration must be continued until the parameter values show a definite convergence. The method of the convergence is proved (Hartley, 1961). Since the calculation is so intricate, a MAPLE computer algebra system or other computer-aided program is required.

#### Matching the extracting-power and stump-diameter function

Stump diameters had been measured (to an accuracy: 1 cm), and then the extracting power was calculated (accuracy: 100 N). In the case of the Scotch pine, we carried out 150 measurements. The extracting power belonging to the identical diameters were averaged, and then a moving average of the 3-3 adjoining data was calculated. These results are displayed in figure 1. On the basis of these data, the (1) function was matched applying the method of estimation. The procedure of iteration was started on the basis of the parameter values displayed in (1) function. To carry out the required matrix procedure, a Maple-programme was written. The procedure of iteration was continued until the accuracy of the required parameter values did not meet the demands, and the suitable place value did not change any more (convergent serial). Parameter values calculated by iteration are displayed in Table 1.

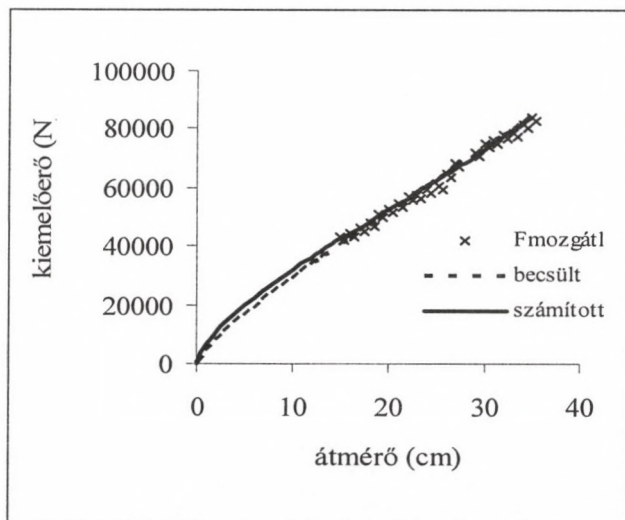

Fig. 1 The estimated and the calculated regressive curve

1. Table: The initial iteration values, the parameter values of the individual steps

	a	b	c
0.	4200,0000	0,8079	0,035000
1.	5964,4973	0,6433	0,050449
2.	6601,4450	0,6293	0,042248
3.	6543,7354	0,6368	0,041236
4.	6541,5993	0,6369	0,041189
5.	6541,6217	0,6369	0,041189
6.	6541,6226	0,6369	0,041189
7.	6541,6226	0,6369	0,041189

So the extracting-power – stump-diameter function result in the case of Scotch pine is as follows: ( $r^2=0,9987$ ):

$$f(x) = 6541,6226 \cdot (x^{0,6369} + e^{0,041189 \cdot x} - 1). \quad (10)$$

This particular mathematical procedure is suitable for the description of any regressive functions when a linear approximation is applied.

#### Experiments to reduce stump extracting power

Several experiments have been carried out to reduce primary input of stump extraction technology. Szepesi (1966) mentioned that application of vibration reduces the primary input by 30-50%. This method allows stumps to be removed entirely cleanly without any soil layer, but on the other hand, very detailed research should be carried out so as to clarify the parameters of vibration (optimal frequency amplitude, vibrated mass).

While our research was being carried out these particular optimal parameters were designed. In the course of our experiments, different tree species and different types of soil have been involved. Our successful FKFP tender provided the financial support for the experiment. Meanwhile, professional support for the experiment was provided by Fluidprogress Ltd. and the Bagodi Mezőgép Company. A sophisticated instrument has been designed and applied to carry out the experiments. The instrument was installed on a tractor. It was a hydraulic driven device with alternating current, and it was designed to stimulate horizontal vibration in order to loosen stumps. The frequency and amplitude of our device was switched into a no-stage operation. Our finding was as follows: although primary input was suitable, (reaching a certain frequency level vibration had a reaction on the tractor, putting it in motion) the amplitude of a vibrating motion is not strong enough to produce a considerable loosening impact on a stump.

To define the reasons the mechanical model of vibration motion was drawn up (2. Figure). In order to define the differential equation of the vibration motion the D'Alambert methods was applied. The unknown coefficients were defined in an experimental way and answers to questions of absorption and motion conditions were given.

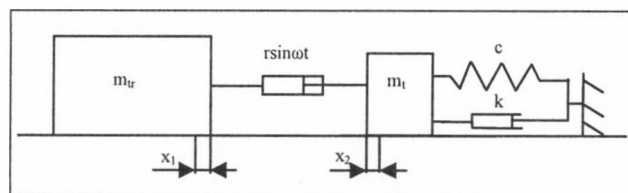

Fig. 2 Mechanical model of the vibration-system

where:

- c spring rigidity factor;
- mt mass of the stump;
- x1 tractor displacement;
- r vibration amplitude;
- k absorption factor;
- mtr mass of the tractor;
- x2 stump displacement;
- ω projected angular velocity.

According to the marking of the Figure 2, the differential equations are as follows:

$$m_{tr}\ddot{x}_1 = m_t\ddot{x}_2 + k\dot{x}_2 + cx_2, \quad (11)$$

$$r \sin \omega t = x_2 - x_1. \quad (12)$$

$$\ddot{x}_1 = \ddot{x}_2 + r\omega^2 \sin \omega t. \quad (13)$$

Having substituted the expression (13) with the expression (11) into the differential equation and suitably rearranged:

$$(m_{tr} - m_t)\ddot{x}_2 + m_{tr}r\omega^2 \sin \omega t - k\dot{x}_2 - cx_2 = 0. \quad (14)$$

Rearranging the equation, the result is as follows:

$$(m_{tr} - m_t)\ddot{x}_2 - k\dot{x}_2 - cx_2 = -m_{tr}r\omega^2 \sin \omega t. \quad (15)$$

Parts of the coefficients are known to be constant, the others can be defined by experiment being concluded by applying mathematical equations, where stump-root-soil system conditions, forces and counter-forces will show how to reduce a suitable force to remove stumps while vibration technology is applied.

#### References

- [1] Szepesi L. (1966): Characteristics and application of forest machinery. Mezőgazdasági Kiadó, Budapest.
- [2] Voronyin K. J. (1967) Masinü i mechanizmü leszozagatovok, leszonzplava i lesznovo.
- [3] Kemény S.-Papp L.-Deák A. (1998): Statistic quality (suitability) regulation. Műszaki Könyvkiadó, Budapest.
- [4] Lukács O. (1987): Mathematical statistics (Bolyai-books). Műszaki Könyvkiadó, Budapest.
- [5] Mundruczó Gy. (1981): Applied regression calculation. Akadémiai Kiadó, Budapest.
- [6] Hartley, H. O. (1961): The modified Gauss-Newton method for fitting of non-linear regression functions. Technometrics, No. 2. 269-280.



# MEASUREMENT OF FOREST ROAD BY GPS

J. Péterfalvi – G Markó  
University of West-Hungary, Sopron

## Introduction

One of the research subfields of the Regional Knowledge Centre for Forest- and Wood Utilization at the University of West Hungary is the elaboration of the geoinformation based registering system for forest opening up networks.

The system to be established demands analogue maps and the information stored on them, not only be retained on the digital map, but also contain actual information with the shortest possible run-through, following the development of the network. In case of roads digital map depicting demands the most realistic visualization of the road axes. Our goal was to examine if the digital map reconstruction of road axes can be adjusted via GPS technics.

## Location of the experiment

As the location of the experiment we have chosen the Csács 2<sup>nd</sup> class forest opening-up road, constructed upon the plans elaborated by our Department for Zala Forestry CIS. The road containing besides the main line two further sublines is located among different topographic and stand conditions. Topography and location of the road is presented in figure 1.

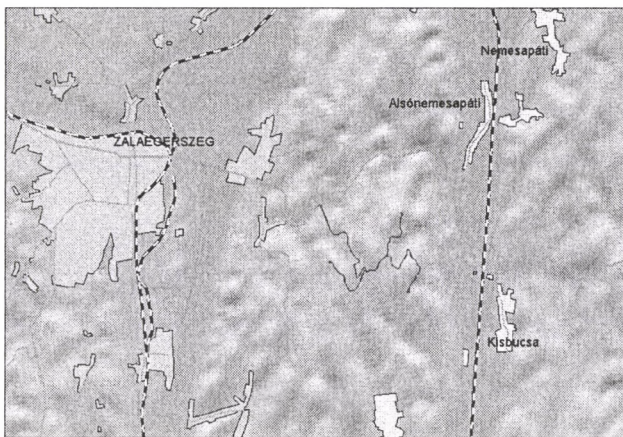

Fig. 1.: Location of the measurement

The chosen location indicated after constructing of the road the accomplishment map was manufactured by the Geodetic and Long-Apprehensive Department of our Institute.

## Measuring with GPS technics

Also serving recording of a tracing of approximate (10-20 metres) accuracy are both a handheld GPS receiver and a iPAQ pocket PC for recording measured positions onto which the digital forest base map can be downloaded. With the help of these both the length of road done by the measuring car and affected parts of the forest were to be traced well. Measuring results verified this handheld tool to use successfully for local navigation

To compare horizontal and actual tracing of the road we used Trimble SST4000 type GPS receiver pair of geodesic accuracy. One of two receivers was positioned in the measuring car, the plate form aerial to be connected to it via cable was positioned on the top of the measuring car with a strong steel foot containing a powerful magnet ( figure 2). The other receiver and its aerial were positioned above a basic point – defined by the data of Zalaegerszeg's permanent station – on a stand. This

receiver was while measuring, continuously receiving and periodically recording satellite signals.

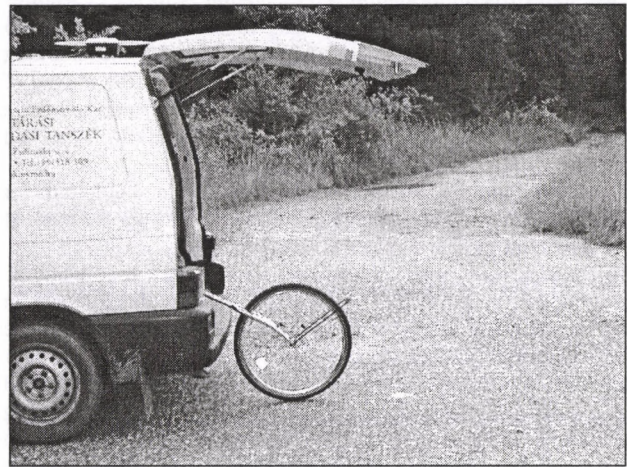

Fig. 2 The measuring car

The accomplishment plan and industrial maps are available in EOJ projection in digital format. Transformation of GPS measuring results received in the WGS84 coordinate system can be performed quickly by using a sufficient number of coordinate points know in both projection systems. Thanks to the Unified Coordinate System with the help of the data of the detailed geodesic survey reliability of measuring results was to be verified.

While measuring differential kinematic GPS measuring was performed via follow-up elaboration. Satellite signs were recorded every second. „Raw” measuring results were evaluated by the help of the software GPSurvey (v. 2.35), WGS-EOJ transformation was performed via DigiTerra Map, and FÖMI EEHHTT programmes. Figure 3. presents a part of the experimental area enlarged, also the reliability of the action among optimal circumstances. Tracing chain connecting GPS measurings is located between the pavement lines, defined earlier, with high accuracy.

A series of measuring has shown, if planning-constructing-surveying activities are performed according to the Hungarian Unified Coordinate System, horizontal and vertical tracing of the constructed road is easily to be controlled afterwards.

Our conclusions drawn from the experiences while measuring was proceeding:

- Technology is to be adapted for a submetre(±10 centimetres) measuring of axes of forest roads demanded by the geoinformation system.
- Main restrictive factuals of the measuring action are forest stand and topography (narrow walleys).
- Method can be combined with traditional methods (total station) on road parts not to be measured by GPS.

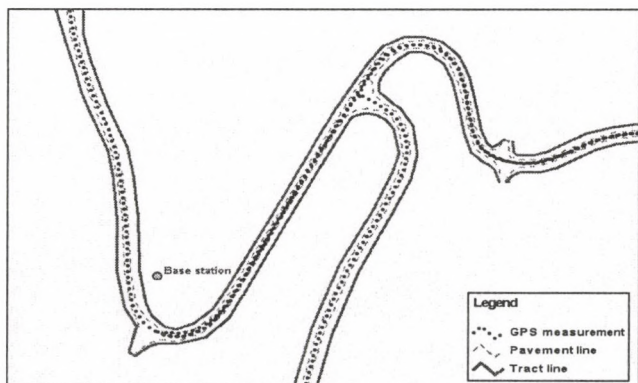

Fig. 3 Results of the measurement

## Digital representation of road axis in the map

First step of geoinformation representation is to select features from the available digital map data file that are necessary to draw the road axis. These objects are mainly polylines marking the bank of the road, being insufficient to present the tracing of the road by themselves. For this the axes of the roads are to be drawn based on the available digital boundary lines and measured data.

The axes of the road are made up of lines, arcs and chlotoids for which reconstruction on the map, polylines marking the bank of the road, and measuring GPS are available.

To reconstruct road axes we apply the road-planning programme "maCADam" elaborated at our department, in which graphical files selected in the geoinformation programme and exported in DXF format can be shown. Graphical user interface renders it for possible lines and arcs of the general plan axis be drawn corresponding best to the facts using boundary lines, and the GPS recording line showing an approximate tracing. Interchangibility between certain programmes is secured by drawing interchange format and the Hungarian Unified Coordinate System.

Axis lines drawn with the help of the programme "maCADam" can be exported again in "dxf" format, which can be visualized by the GIS programme.

In the geoinformation system the network of established road axes provides a proper map background to found the database system of the road network

## Apprehensions for development

Our further research apprehensions to develop the method:

- Measurements performed during the winter, examining of differences between the affects of branched/bald forest stand.
- Examining of more up-to-date GPS receiver pairs and aerals.
- Extending the method to controll height tracing.

## References

- [1] Czimber Kornél: Geoinformatika. Egyetemi jegyzet. Soproni Egyetem, Sopron, 1997.
- [2] Kosztka M.- Markó G.-Péterfalvi J.: Az erdészeti feltáróhálózat mint az erdőgazdálkodás logisztikai alapja. MTA AMB Kutatási és Fejlesztési Tanácskozás. Gödöllő 2002.
- [3] Markó G.-Péterfalvi J.: Digitális felületmodell alkalmazása erdészeti feltáróhálózatok és feltáróutak tervezésénél. MTA AMB Kutatási és Fejlesztési Tanácskozás. Gödöllő 2004.

# EFFECT OF MOISTURE CONTENT CHANGE ON COLOUR CHARACTERISTICS OF PAPRIKA POWDER

Zs. H. Horváth – A. Véha

Faculty of Food Engineering, University of Szeged

## Introduction

The use of natural food colours is preferred to that of artificial dyestuffs for by modern alimentary purposes. Paprika is a spice plant grown and consumed in considerable quantities worldwide, and also used as a natural food colour. Hungarian paprika powder is still regarded as a "Hungaricum" today. Paprika is cultivated in areas of the world such as Spain, South Africa and South America, where the weather is favourable for the growth of this plant and for the development of its red colouring agents. The large number of hours of sunshine allows the paprika to ripen on its stock, so that the basic material reaching the processing mills has a high dyestuff content. Hungarian paprika has a unique aroma and a specific smell, but the production of powder with a good red colour is a considerable problem.

Various investigations have been made of the connection between the colouring agent content of the powder and the colour characteristics measured by different techniques (NAVARRO et al., 1993, NIETO-SANDOVAL et al., 1999). Such investigations have yielded partial results, but there is no formula that describes the correlation between the colouring agent content and the colour characteristics. The colour of the powder is influenced by many factors besides the colouring agent content. Since the 1970s a number of papers have been published on measurements of the colour of paprika powders (HORVÁTH et al., 1973, DRDAK et al., 1980, HUSZKA et al., 1984, DRDAK et al., 1989).

Measurements have been performed relating to the changes in the colour stimulus components X, Y and Z of powders during mixing (HUSZKA et al., 1984) and to the correlation between visual sensing and the instrumentally measured colour characteristics (HUSZKA et al., 1985).

The effects of ionizing irradiation on the colour of paprika powder were investigated by FEKETE-HALÁSZ et al. (1996).

MINGUEZ et al. (1997) analysed how the colour of the powder is changed by the ratio of the yellow and red pigments within the total colouring agent content.

CHEN et al. (1999) investigated the effects of particle size in Korean cultivars and established that the lightness coordinate of the powder was influenced by the particle size. Applying a home milling technique, HORVÁTH & HALÁSZ-FEKETE (2005) demonstrated that the particle size exerts a significant influence on all three colouring characteristics of powders made from Hungarian, South African and South American paprika.

KISPÉTER et al. (2003) investigated the influence exerted on the colour by saturated steam used for germ reduction.

The colour of the powder was observed to become turns into darker and deeper red with increasing moisture content. In the case of Korean cultivars, no significant change in colour characteristics was detected when the moisture content was varied between 10% and 15% (CHEN et al., 1999).

## Objective

The aim of the present work was to study how the colour characteristics of Hungarian paprika powders change following increase of the moisture content.

## Materials and methods

### Determination of moisture content

Moisture content was determined according to Hungarian Standard MSZ 9681-3 relating to paprika powders.

5 g of powder in a scale pan was weighed with an accuracy of 0.002 g. The open pan was then placed into a drying oven and the sample was dried for 4.5 hours at 95±2 °C. Thereafter the covered scale pan was cooled in a desiccator for 30 minutes, and the total mass of the pan and the sample was measured. The moisture content was calculated from the measured mass loss.

### Colour measurement

Colour measurements were performed with a Minolta CR-300 tristimulus colour measuring instrument. The CIE 1976 L\*, a\*, b\* colour system was used for colour characterization.

In this colour space colour points are characterized by the colour coordinates defined by the following equations and given as rectangular coordinates:

$$\begin{aligned} L^* &= 116(Y/Y_0)^{1/3} - 16 \\ a^* &= 500[(X/X_0)^{1/3} - (Y/Y_0)^{1/3}] \\ b^* &= 200[(Y/Y_0)^{1/3} - (Z/Z_0)^{1/3}] \end{aligned} \quad (1)$$

where X, Y and Z are the trichromatic values of the coloured object, while

X<sub>0</sub>, Y<sub>0</sub> and Z<sub>0</sub> are the trichromatic numbers of white achromatic (LUKÁCS, 1982).

Colour difference (ΔE\*<sub>ab</sub>) is given in terms of the spatial distance between two colour points interpreted in the colour space:

$$\Delta E^* = \left[ (\Delta L^*)^2 + (\Delta a^*)^2 + (\Delta b^*)^2 \right]^{1/2} \quad (2)$$

Table 1 shows the relationship between the value of the colour difference ΔE\*<sub>ab</sub> and the visual observation on the paprika powder.

Table 1 Relationship between ΔE\*<sub>ab</sub> and visual observation

ΔE* <sub>ab</sub>	Visual sensing
ΔE* <sub>ab</sub> ≤ 1.5 or (1.5 < ΔE* <sub>ab</sub> ≤ 2.0 and  ΔL* ,  Δa* ,  Δb*  < 1.5)	No difference
1.5 < ΔE* <sub>ab</sub> ≤ 2.5	A hardly perceptible difference
2.5 < ΔE* <sub>ab</sub>	A definitely perceptible difference

The equations used to describe the hue difference (ΔH\*<sub>ab</sub>) and chroma difference (ΔC\*<sub>ab</sub>) between two colour points are as follows:

$$\Delta H_{ab}^* = \text{sign}(a_1^* \cdot b_2^* - a_2^* \cdot b_1^*) \cdot \left[ (\Delta E_{ab}^*)^2 - (\Delta L^*)^2 - (\Delta C_{ab}^*)^2 \right]^{1/2} \quad (3)$$

$$\Delta C_{ab}^* = \left[ (a_1^*)^2 + (b_1^*)^2 \right]^{1/2} - \left[ (a_2^*)^2 + (b_2^*)^2 \right]^{1/2} \quad (4)$$

### Sample preparation and colour measurement

Ten different powder samples were prepared from different Hungarian paprika varieties. Samples were taken immediately after milling before adjustment of the moisture content. The average particle size of the powders was between 260 μm and 320 μm. In the first step, the moisture contents of the powders were determined as detailed in section 2.1. The values obtained are shown in Table 2.

Table 2 reveals that the moisture contents of the initial paprika powders lay between 6.85% and 7.56%. The maximum moisture content allowed for paprika powder is 11% (CODEX ALIMENTARIUS HUNGARICUS, 1997). The moisture content of each of the samples was next increased by 1%, 2%, 3%, 4% and 5% relative to the initial sample. The moisture contents of the measured powders therefore ranged up to 12.56%. Accordingly, the moisture contents of some of the samples were higher than the permitted limit.

**Table 2** Moisture contents of samples

Sample	Moisture content, %
P1	6.85
P2	6.99
P3	7.02
P4	7.09
P5	7.18
P6	7.21
P7	7.28
P8	7.32
P9	7.42
P10	7.56

The moisture contents of the samples were increased in the following way: via the moisture contents of the initial powders ( $n_0$ ), equation (5) was applied to calculate how many grams of water must be taken up ( $x$ ) to increase the moisture content by  $p\%$  for a given mass( $m$ ).

$$x = \frac{m \cdot p}{100 - n_0 - p} \quad (5)$$

Thereafter, samples of 5 g of powder were weighed with four-digit accuracy on an analytical balance, and then placed into a desiccator, the lower part of which was filled with water at 70–80 °C. The samples were kept in the desiccator until their masses had increased by 1%, 2%, 3%, 4% or 5% because of moisture uptake. The colour characteristics of these samples were determined in 3 parallel measurements.

The data obtained were evaluated by using variance analysis of one factor.

**Results and discussion**

Tables 3a, 3b and 3c present the variance analysis results.

**Table 3a** Variance table for lightness coordinate  $L^*$

Source of variation	SQ	DF	MQ	F-ratio	p
Between groups	32.28	5	6.46	2.23	0.0534
Within groups	503.73	174	2.89		
Total	536.00	179			

**Table 3b** Variance table for redness coordinate  $a^*$

Source of variation	SQ	DF	MQ	F-ratio	p
Between groups	24.73	5	4.94	0.69	0.6283
Within groups	1239.45	174	7.12		
Total	1264.18	179			

**Table 3c** Variance table for yellowness coordinate  $b^*$

Source of variation	SQ	DF	MQ	F-ratio	p
Between groups	136.76	5	27.35	3.88	0.0023
Within groups	1224.47	174	7.07		
Total	1361.47	179			

The data in Tables 3 demonstrate the lightness and yellowness coordinates were significantly influenced by increasing moisture content, whereas there was no influence on the redness coordinate.

As concerns the detailed analysis, the average values of the colour coordinates are presented in Figs 1-3, differences being taken as significant at a level  $p = 0.05$ .

It can be seen that the lightness coordinate  $L^*$  progressively decreased with increasing moisture content. An added 3% moisture content caused a significant and well-perceptible change. Further added water did not induce any additional perceptible decrease.

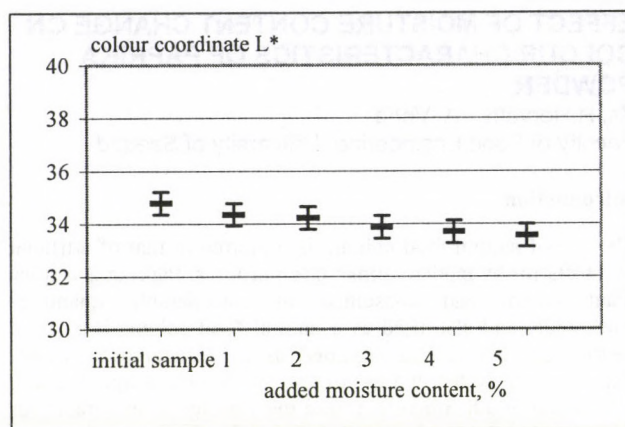

**Fig. 1** Result of variance analysis of lightness coordinate (average  $\pm$   $SD_{0.05}$ )

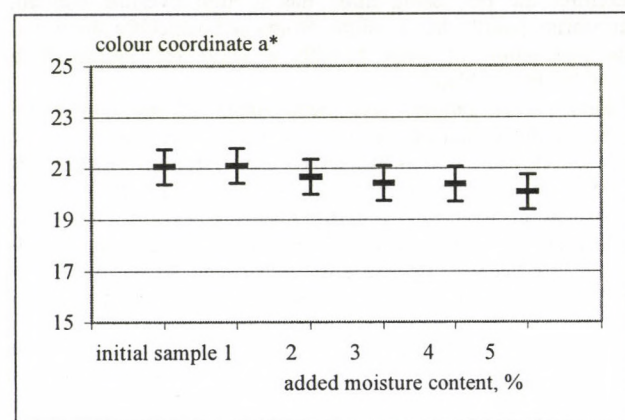

**Fig. 2** Result of variance analysis of redness coordinate (average  $\pm$   $SD_{0.05}$ )

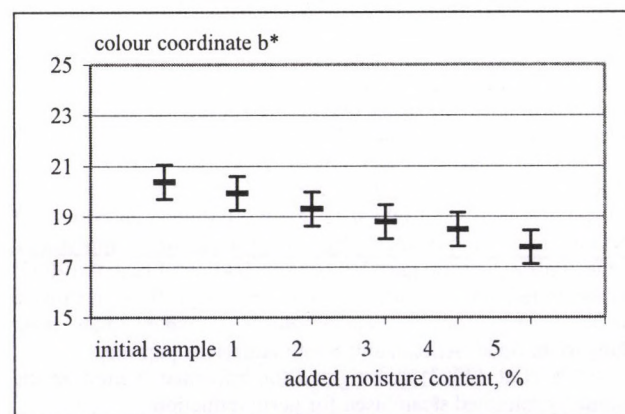

**Fig. 3** Result of variance analysis of yellowness coordinate (average  $\pm$   $SD_{0.05}$ )

The average value of redness coordinate  $a^*$  similarly decreased with increasing moisture content, but the change was not significant.

As compared with the initial sample, the difference was only 0.8 unit at an added moisture content of 5%.

The yellowness coordinate  $b^*$  changed more strongly. With increasing moisture content, the average values of  $b^*$  decreased significantly: by 1.7 and 2.2 units at added moisture contents of 3% and 5%, respectively.

The colours of the samples with the different moisture contents were estimated visually. It was observed that, in parallel with increasing added water content, the colour of the samples became darker red. The colour ( $\Delta E^*_{ab}$ ), chroma ( $\Delta C^*_{ab}$ ) and hue ( $\Delta H^*_{ab}$ ) differences of the initial samples and the samples with

various added moisture contents were calculated to determine the changes in colour. The values are shown in Figs 4, 5 and 6.

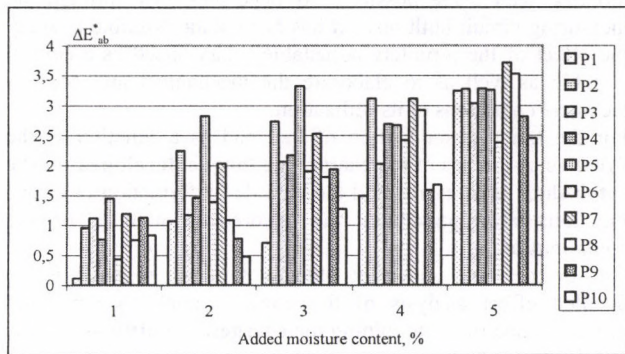

Fig. 4 Colour differences of initial samples and samples with added moisture content

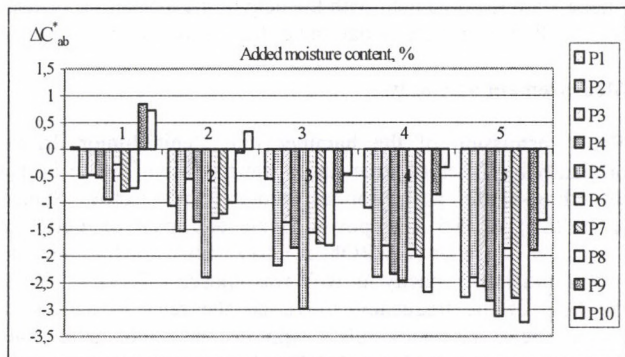

Fig. 5 Chroma differences of initial samples and samples with added moisture content

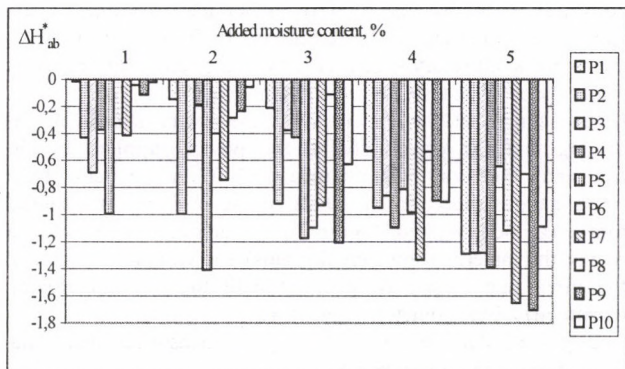

Fig. 6 Hue differences of initial samples and samples with added moisture content

The colour difference exceeded the visible value to extents depending on the powder, the difference between them and increasing progressively with the increase of the added moisture content. The chroma difference was generally negative and became more negative with increase of the added moisture content. This means that the paprika powder became less coloured and less saturated.

The hue difference was also negative and became more negative with increase of the added moisture content. This indicates that the paprika powder became redder.

#### Conclusions

- ✓ The lightness coordinate  $L^*$  gradually decreases with increasing added moisture content. A significant and perceptible change relative to the initial samples is observed at an added moisture content of 3%. Large additions of moisture do not effect a perceptible additional decrease.

- ✓ The redness coordinate  $a^*$  does not change perceptible with increase of the added moisture content between 1% and 5% for samples with initial moisture contents of 6.85-7.56%.
- ✓ The yellowness coordinate  $b^*$  decreases with increasing added moisture content. The difference is significant: 1.7 and 2.2 units for moisture content additions of 3% and 5%, respectively.
- ✓ The colour difference exceeds the visible value to extents depending on the powder at the various added moisture contents.
- ✓ The changes in the colour characteristics as the added moisture content is increased can be observed visually: the powders became darker and redder, but less coloured.

#### References

- [1] CHEN Q., HAK-KYUN-KOH, JAE-BOK-PARK (1999): Color evaluation of red pepper powder, *Transaction-of-the-ASAE*. 42(3), 749-752.
- [2] CODEX ALIMENTARIUS HUNGARICUS(1997): 2-8720, Paprika powder
- [3] DRDAK M., SORMAN L., ZEMKOVA M., SCHALLER A.(1980): Ergebnisse von Studien über den Zusammenhang zwischen Zusammensetzung und Farbe von gemahlenem Gewürz-paprika, *Confructa*, 25(3/4), 141-146.
- [4] DRDAK M., GREIF G., KUSY P.(1989): Comparasion between the sensory and spectrophotometric method for determination of colour of paprika powder, *Nahrung* 33(8), 737-742.
- [5] FEKETE-HALÁSZ M., KISPÉTER J. (1996): Effect of irradiation on colour of ground red paprika. *Acta Alimentaria* 25(2), 189-193.
- [6] H.HORVÁTH ZS., HALÁSZ-FEKETE M. (2005): Instrumental colour measurement of paprika powder. *8<sup>th</sup> International Symposium on Interdisciplinary Regional Research, Szeged, 2005.*, CD of Conference
- [7] HORVÁTH L., KAFFKA K. (1973): Instrumental Colorimetry of Red-pepper Grist, *Mérés és Automatika* 21(9) 341-348. (In Hungarian)
- [8] HUNGARIAN STANDARD (2002): Investigation of paprika powder, detemination of moisture content: MSZ 9681-3
- [9] HUSZKA T., HALÁSZNÉ, HORVÁTH M. ZS., LUKÁCS GY. (1984): Számítógépes színrecept számítási eljárás fűszerpaprika őrlmények optimalizált előállítására. *Mérés és Automatika*, 32(5) 170-177.(In Hungarian)
- [10] HUSZKA T., HALÁSZ-FEKETE M., LUKÁCS GY. (1985): Colour Tolerance of Red-Pepper Powders, *Hungarian Scientific Instruments* 60, 43-47.
- [11] HUSZKA T., HORVATH, ZS., HALÁSZ-FEKETE, M., VÉHA, A., GYIMES, E. (1990): Computer aided quality planning and production control of red-pepper powders, *4<sup>th</sup> European Seminar of the EOQ Food Section, Berlin, Proceedings*, 176-178.
- [12] KISPÉTER J., BAJÚSZ-KABÓK K., FEKETE M., SZABÓ G., FODOR G., PÁLI T.,(2003): Changes induced in spice paprika powder by treatment with ionizing radiation and saturated stream. *Radiation Physics and Chemistry* 68, 893-900. LUKÁCS GY. (1982): Colour Measurement. *Műszaki Kiadó*, Budapest (In Hungarian)
- [13] MINGUEZ-MOSQUERA MI, PEREZ-GALVEZ A. (1997): Color quality in paprika oleoresins, *Journal of Agricultural and Food Chemistry* 46 (12), 5124-5127.
- [14] NAVARRO F, COSTA J (1993): Evaluation of Paprika Pepper Color by Trisestimulus Colorimerty, *Revista Espanola de Ciencia y Tecnologia de Alimentos* 33(4):427-434.
- [15] NIETO-SANDOVAL JM, FERNANDEZ-LOPEZ JA, ALMELA L, MUNOZ JA (1999): Dependence between apparent color and extractable color in paprika, *Color Research and Application* 24, 93-97.

## MEASUREMENT ASSEMBLY FOR ENERGETIC ANALYSIS OF COMMINUTERS

P. Korzenszky – E. Judak  
Szent István University, Gödöllő

### Introduction

Taking the results gained up to now, in the course of the mechanical investigations on comminuting machines (first of all impact mills) as a basis, a new measurement system was constructed. The system is suitable for investigating the states in continuous regime ranges as well between the earlier set discrete parameters as against that in the former stepped measurements. Besides the infinitely variable rotary-speed adjustment, the measurement assembly is usable and indispensable to the work on understanding better the comminution process and grounding its comminution-kinetic description. On the basis of the analysis of the experiments carried out and the conclusions drawn, a mechanically and energetically well-founded control and regulation circuit, utilizable in the practice as well, can be elaborated. The system with its present form, through using the independent parameters revealed during the investigation, is already capable of operating as a feedback regulation circuit (it may be considered a pilot-scale control device as well).

### Directly measured and influenced variables

The performance of the mill is given as the **mass flow rates** of the feed (input) and/or the outflow (output) material (kg/s or t/h), which are alike in the case of the stationary running, at an actual grits fineness. The particle fineness is a datum that can be defined and given from indirect measurements (sieve analysis) effected on samples, with the knowledge of the particle-size distribution curve. Its direct measurement in the process has not been solved yet; at present it can be carried only by manual input in control program for the reference-signal creation. One of the objectives of the research is to create such a fineness-dependent physical-mechanical property which can be measured directly and to which a suitable electrical measuring transducer (transmitter) might be developed. This is allowed by the improved measurement system. The built system completed with the computer data processing is alike capable of taking the characteristics necessary for transformation of the non-stationary regime (when the input and the output material-mass flow rates are not equal and they vary as a function of time).

The comminution process, besides the design of the crushing elements, the grinding chamber and the liner, is determined by the mass and the motion state of the **charge** (the material being instantly in the grinding chamber). The mass of charge can be determined exactly through comparing the diagrams of the input and the output masses (kg) against time. To this, the measuring system continuously detects the weight of the material to be fed namely its decreasing and the weight of the output (its accumulation) and the computer records the gained mass-time functions in a form for processing.

The state of motion of the charge is a complex of the motions and collisions of the single particles that are determined by the superposed elementary interactions. For its examination, the most important dynamic parameter, besides the charge mass and the particle-size distribution by mass, is the **peripheral velocity of the rotor** which at once is an input property as well. The discrete records of the earlier research (carried out at some velocity i.e. rotary-speed stages several times respectively) have proved that the dynamic functions of the impact mills (mass-flow rate, grits fineness and loading torque as functions of rotary speed) have extreme values at well-defined places of which comminution-kinetic analysis is of cardinal importance and interest for us. By that measurement system in a greatly widened and increased rotary-speed range, taking continuous

dynamic functions, the comminution-kinetic analysis of the significant values or value-pairs including the model creation too has been made possible. At once and only through the measuring circuit built now, it has been made possible to study the effect of the infinitely adjustable rotary speed as a control variable as well as to elaborate the mechanical and control-technical conditions of its utilization.

For the kinetic examination of the load as a function of the dynamic properties of the charge, the **torque developed on the rotor shaft** is measured and the recorded information or torque functions are applied in the theoretical analysis of the comminution.

One of the most important objectives of the research is the detailed effect analysis of the constructional, dynamic and process properties determining the **energetic conditions** and the **efficiency** (which is extremely bad at the mills) of the comminution. For that, records of large number with several constructional version, settings, material states and product fineness are required that, with the help of the measuring system built, with effective many-parameter tests, is possible.

### Measurement assembly

The transmission of the hammer mill Zenit Junior driven originally by V-belt of three stages was modified (Figure 1). To the three-phase asynchronous motor type Leroy Somer (LS132ST) of 5.5 kW power, with one pair of poles, a frequency converter (OMRON 3G3MV) fitted to the motor in power and load capacity as well was chosen (Figure 2). With the help of the frequency converter, the rated synchronous rotary speed of motor 3000 rpm is infinitely adjustable theoretically between 0 and 400 Hz. Arising from the design of the motor and some other reasonable parameters, it was temporarily expedient to limit the output of the frequency converter to 60 Hz that slightly higher than the rated rotary speed. Now the range to be tested will be 0 to 3600 rpm as to the motor-shaft rotary speed. However, the range for the motor rotary speed to be tested will be much wider.

In the course of the experiments, the rotary speeds of the driving and the driven shafts, the power supplied by the frequency converter will be measured. With the help of the strain gauges glued on the shaft of the mill, the mechanical torque can be measured (Figure 3). To determine the mass-flow rate of the material (now cereal grains), the variation in mass of the input and output is recorded with the help of electro-tensometric dynamometers (Figure 4).

The gained data are recorded by a measuring and data-acquisition device (SPIDER 8).

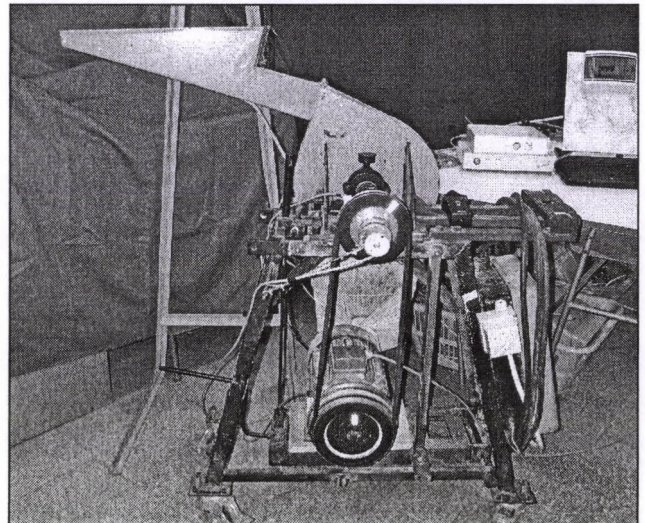

Fig. 1 Zenit Junior hammer mill

The frequency converter is used in the application according to the instruction manual provided by OMRON. The power value is selected on the programmable transmitter (0 to 10 V = 0 to 5.5 kW) (Figure 2).

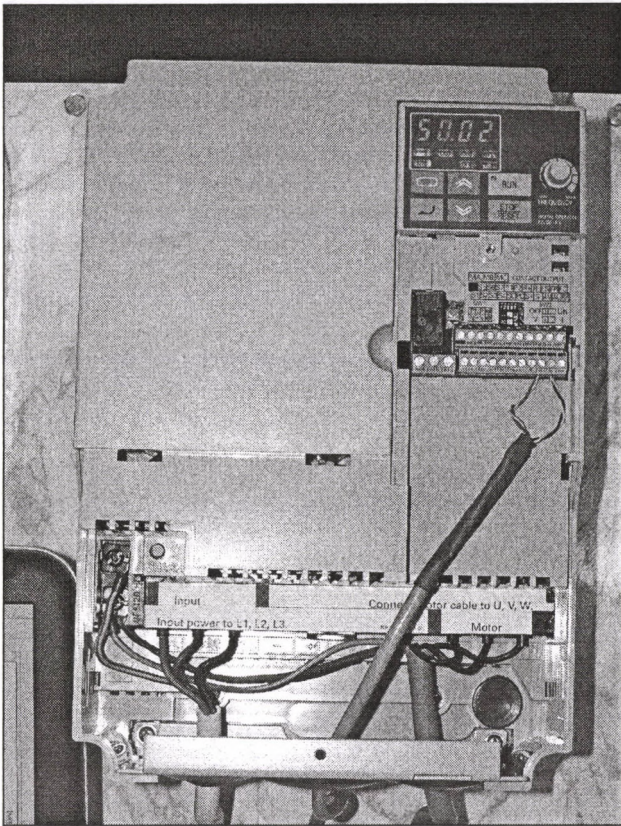

Fig. 2 Terminal connection diagram of the frequency converter type OMRON 3G3MV

To determine the mechanical torque, strain gauges were glued on the shaft of the mill. The calibration of the torque measuring circuit was carried out in static state in such a way that weights of known mass were placed at a 0.5 m distance from the shaft axis and the voltage between the bridge arms was measured. The terminals of the strain gauges were led in a groove milled in the shaft to the shaft end (Figure 3).

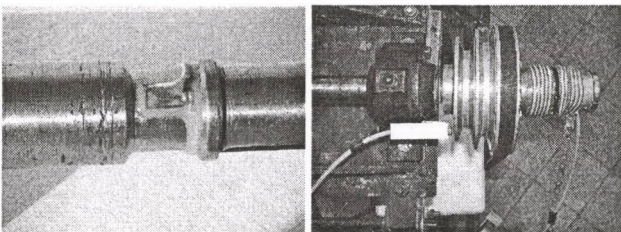

Fig 3 Torque meter assembled with slip-ring pickup

The measurement of rotary speed was provided with the help of transmitters working on reflection principle (Figure 3.b).

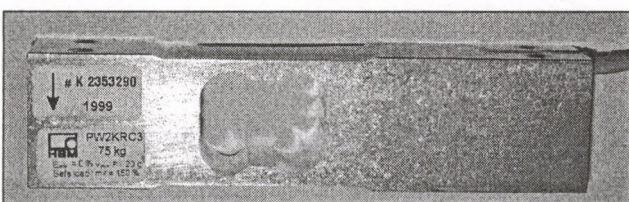

Fig. 4 Electro-tensometric dynamometer Hottinger PW2KRC3

The measurement and data-acquisition device SPIDER 8 is capable of simultaneously collecting samples 8 independent parameters (variables). The first two channels (0 and 1) are capable of receiving impulse-like quantities, the channels 6 and 7 – outputs of universal transmitters (0 to 10 V; 4 to 20 mA) and full, half- and quarter bridges can be connected to the other channels (Figure 5).

The schematic diagram of the measurement assembly is shown in Figure 6.

Before the elaboration of the experimental project, an idle-running measurement series was also carried out. The data from the evaluation of a test are shown in Figure 7.

The rotary speed of the motor shaft has been adjusted to the 3000 rpm rated value, the rotary speed of the rotor, according to the V-belt transmission, is 3600 rpm. The higher power required by the starting can also be followed well in the preset 8 s running-up period. In the stationary range, the value of the power is 2.2 kW while, in the dynamic period (speed-up), the power has reached the 3.4 kW instantaneous value. The increasing tendency can be observed in the torque values as well but it is not of a significant degree in the case of idle running.

The evaluation of the idle-running measurement raises several ideas for making more exact the later experimental presetting. Through an accurate selection of the starting boundary conditions, the process will be enabled to start in operating states different from the rated load. The incidental power peaks may be eliminated on the basis of the data gained from the test series.

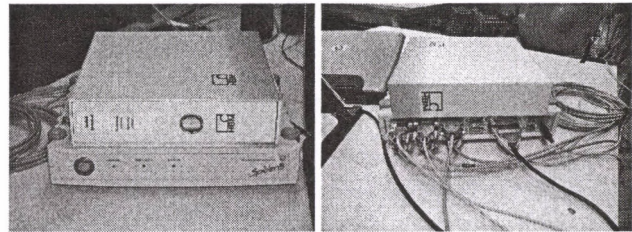

Fig. 5 Channel assignment of data-acquisition device SPIDER 8

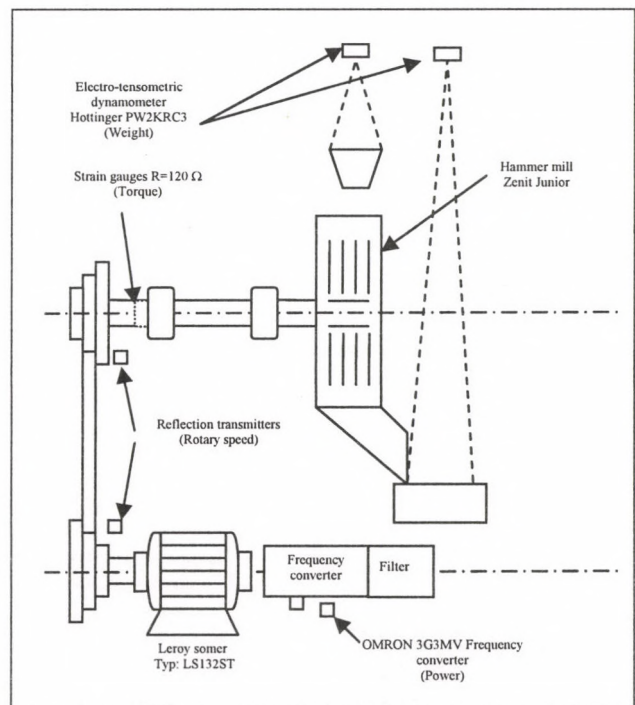

Fig. 6 Schematic diagram of the measurement assembly

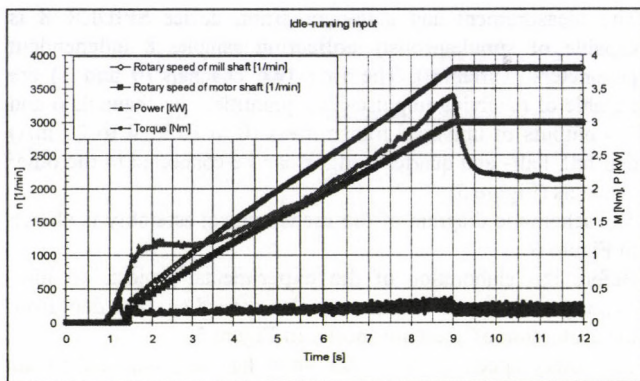

Fig. 7 Evaluation of idle-running input

## References

- [1] Fogarasi L. – Douba M. – Sembery P. (1996): Grinding Cereal Grains by Hammer Mill. (Gabonafélék aprítása kalapácos darálóval) Hungarian Agricultural Engineering 1996. No. 3 (31 – 35. p. HU ISSN 0864 – 7410) (10)
- [2] Fogarasi L. – Douba M. – Sembery P. (1996): Relations between Surface Geometry of Hammer Mills and Energetic Parameters. (Összefüggés a kalapácos darálók felületi kialakítása és az energetikai paraméterek között) Hungarian Agricultural Engineering 1996. No. 9 (54-57. p. HU ISSN 0864 – 7410) (10)
- [3] Judák E. – Fogarasi L. – Korzenszky P.: Forgó villamos gépek hatásfok-analíziséhez mérőrendszer kifejlesztése és tesztelése terménydarálón. XXVI. K+F Tanácskozás 2002. január 15–16. SZIE, Gödöllő (1)

# APPLICATION OF ULTRASOUND TECHNIQUES IN WASHING PLASTIC BOXES AND CRATES

Gy. Mészáros<sup>1</sup> - Z. Csizmazia<sup>2</sup>

<sup>1</sup>College of Food Engineering of the University of Szeged.

<sup>2</sup>Centre of Agricultural Science University of Debrecen

## Introduction

The food industry uses a large amount of plastic cases, boxes and containers for transportation within and outside of the company. These contain strong bounded dried, bloody and fatty contaminations. Their removing is difficult especially in case of complicated surfaces. The traditional washing machines equipped with high pressure nozzles are not able to remove the contaminations from places situated in shaded areas (ribs, holes, and corners). It can not be accepted in case of tools having direct contact with foods. Therefore we investigated the introduction of ultrasonic procedure for cleaning of objects having complicated surfaces.

## Literature review

### *Fundamentals of industrial cleaning*

In the food industry can be found biological, non wetting and surface adhering contaminants first of all. Different cleaning technologies, using a combination of mechanical chemical and solving effects, are applied for removing them. The solving of the contamination is an important task in the course of cleaning. The formerly properly quelled and peptised contamination can be removed more easily. It is made by mechanical scrubbing or washing solution high pressure streaming out from nozzles traditionally. Another task is the disinfection for destroying the harmful microbes. These operations are influenced by different physical and chemical characteristics.

- Treating time
- Temperature of the detergent,
- Chemical composition of the detergent,
- Concentration of the detergent,
- Form and impulse power of the protruding fluid flow.

The efficiency of the operations can be significantly improved by proper choosing the values of the above mentioned factors (1).

### *Mechanical cleaning of cases boxes and containers*

The sophisticated and efficient mechanical cleaning has to be consisted of the following operation steps in case of strong adhered biological contamination:

- pre-soaking, pre-washing,
- intensive washing,
- rinsing and disinfection,
- rinsing,
- drying.

These phases are separated within the applied machines and have an individual fluid treating and transportation systems. A transporting device conveys the objects through the phases of cleaning in case of continuous cleaning in large scale factory. Their configurations are passed to the object to be cleaned, their length and moving speed depends on the measure of the contamination and the washing capacity (2,3,4,5).

The literature survey and the practical experience showed that there are several deficiencies of the procedures and equipments used till today and in case of most modern solutions as well. The pre-washing and pre-soaking phase is missing or too short generally. Most of the contaminations are not slacked in this way. Shaded areas are always remaining for the cleaning.

Further practical deficiency is that the applied solving reagent is not suitable for the art of the contamination, making the technology inefficient (6,7,8).

## The aim of the investigation

We have tried to demonstrate with comparative tests that the efficiency of the cleaning of the strongly adhered and dried biological contamination can be improved if the pre-soaking washing and ultrasonic treatment are combined.

To determine the most important operation parameters (time and temperature) by which the combined cleaning procedure gives satisfactory success on the base of the experimental results.

## Materials and methods

### *The effect of the ultrasound in the fluid*

The ultrasound is a mechanical oscillation for which the laws of acoustics are valid. Its more important physical parameters:

- high frequency range (20 kHz-1000 MHz),
- low wavelength,
- The transmitted waves stepping out from the resonator (electromagnetic transformers) can be directed,
- It can be created with high intensity.

The acoustic oscillation transmitted with high intensity causes detectable changes in the fluids. The characteristic and most important effect in the point of view of cleaning is the cavitations. The sound waves spreading in the fluid create a propagating high and low pressure periods in sequence. The fluid is disrupting in the attenuating region and numerous small bubbles are created. In the next moments, in the pressurised phase, these holes are eliminated accompanying a local shock wave having  $10^5$  N/m<sup>2</sup> pressure. This is the explanation of the destructing and eroding effect of the cavitations. The most advantageous frequency region of the cavitations is 18-44 kHz and the best temperature region is 55-65°C for cleaning. The erosion due to the cavitations can be intensify if the fluid is a properly chosen cleaning solution (9,10).

### *Model experiments for the determination of the efficiency of the ultrasound cleaning*

In the course of the model experiments we have determined how the cleaning efficiency can be increased by changing the temperature and time within the definite region. We have compared the cleaning by soaking and ultrasound and their combinations.

### *Measuring the cleaning efficiency*

In the course of the experiments the contamination must be reproducible. Therefore the investigated surfaces had the same type and amount of contamination, the temperature and concentration of the applied solvent had constant values. In this way the initial conditions of the solving and cleaning process remained constant. We carried out two kinds of experiments: cleaning with ultra sound and without it in the same solution. In this way the graphical and numerical comparisons could be carried out directly.

The efficiency of cleaning is the following (1):

$$\eta = \frac{m_0 - m}{m} \leq 1 \quad (1)$$

where

$m_0$

amount of original contamination [g]

$m$

amount of contamination remaining after treatment [g]

These were measured in dry state with a balance having 0,01 g accuracy. The test contamination was a dried milk. It was dried onto the surface of each sample piece of containers under the same conditions.

*Cleaning effect vs. time*

**Investigated material:** plastic container  
Dried milk on its elements  
**Solvent:** 1 % NaOH, 65°C alkaline solution  
**Ultrasound equipment:** TESLA UG 160/320 TA, 20 kHz  
**Volume:** 10 dm<sup>3</sup>  
**Treatment:** 50-60 sec long treatment with ultrasound and without it.  
**Method:** 5 measurements in each treatment time. The average efficiency of 5 measurements can be found in Table 1 ( $\eta_{US}, \eta_S$ )

**Table 1** Cleaning time and cleaning efficiency of ultrasound and soaking cleaning

Time t (s)	Average efficiency of ultrasound treatment ( $\eta_{US}$ )	Average efficiency of soaking treatment ( $\eta_S$ )
5	0,41	-
10	0,77	0,22
25	0,86	0,53
30	0,91	0,61
35	0,90	0,63
40	0,93	0,61
50	0,92	0,63
60	0,96	0,67

The values of the table are depicted on Figure 1. The power function of  $y = 1 - e^{-ax}$  is fitted on the efficiency values of soaking and ultrasound treatment [(2) and (3) equation]. The obtained correlation coefficients were 0.9170 and 0.8810 for soaking and ultrasound treatment respectively.

$$\eta_S = 1 - e^{-0,0248t} \quad (2)$$

$$\eta_{US} = 1 - e^{-0,11104t} \quad (3)$$

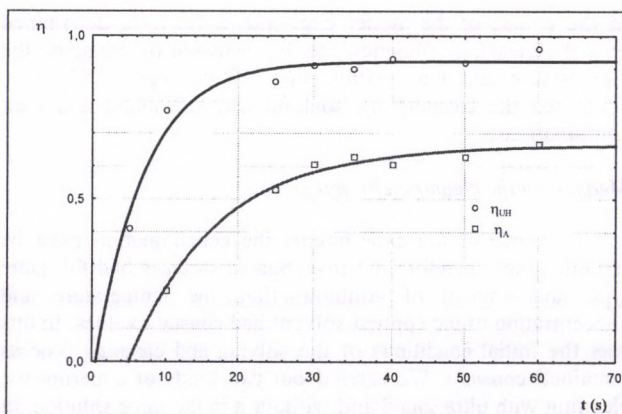

**Fig. 1** Efficiency of soaking and ultrasound cleaning vs. time

*Cleaning effects in dependence of temperature*

The material, solvent and investigation equipment were the same as in previous chapter.

**Treatment:** Constant  $t = 60$  sec treatment time and the temperature was changed between 20-65°C. The measuring figures are shown in Table 2:

**Table 2** Cleaning temperature and cleaning efficiency

Temperature (°C) $\theta$	Average efficiency of ultrasound treatment ( $\eta_{UH}$ )	Average efficiency of soaking treatment ( $\eta_S$ )
20	0,73	0,4
30	0,78	0,4
35	0,77	0,54
40	0,79	0,53
50	0,92	0,6
60	0,88	0,66
65	0,99	0,67

The values of the table are depicted on Figure 2. A linear line ( $y=a+bx$ ) was fitted on the figures ((4) and (5) equation). The obtained correlation coefficients were 0.9266 and 0.9563 for ultrasound and soaking cleaning respectively.

$$\eta_{US} = 0,607 + 0,005\theta \quad (4)$$

$$\eta_S = 0,263 + 0,007\theta \quad (5)$$

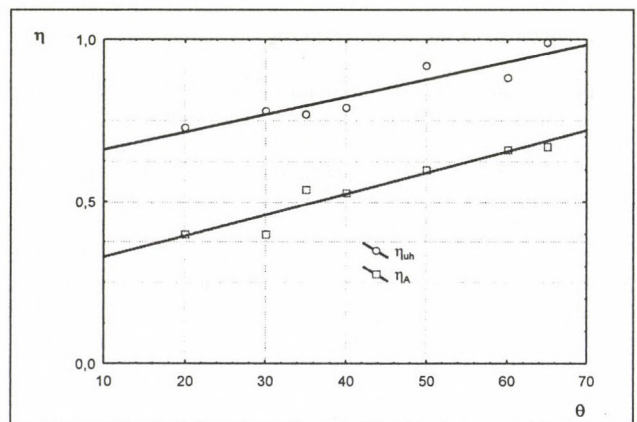

**Fig. 2** Efficiency of soaking and ultrasound cleaning vs. temperature

*Cleaning operation in two stage*

In this experiment we investigated how develop the cleaning efficiency in dependence on time if we soaking cleaning was combined with ultrasound after a definite time. Similar to the earlier experiments the soaking was carried out in solvents of 1% NaOH at 60°C and for 30 s, and then the solvents was treated with 20 kHz ultrasound for 30 s. The efficiencies shown in Table 3 were calculated from 5 measurements:

**Table 3** Efficiency of soaking and combined cleaning

	$t_S$ (s)				$t_{comb}$ (s)				$\eta_{UScomb}$
	10	20	30	35	40	50	60		
$\eta_S$	0,32	0,57	0,59	0,72	0,85	0,87	0,93		

The values of the table are depicted on Figure 3 showing the change of the efficiency in the course of time. On the Figure 4 we show the data of Figure 1 and the data of combined treatment shown Figure 3.

**Discussions**

In the cleaning operation, involving physical and chemical processes and diffusion phenomenon as well, the time and temperature play a significant role (11., 12., 13., 14.).

The first experiment series showed that the cleaning efficiency changes in time as an exponential function approximating 1. The efficiency of cleaning changes only slightly after a definite time (Figure 1). Therefore the treatment time must be limited to a high efficiency accompanying reasonable running costs.

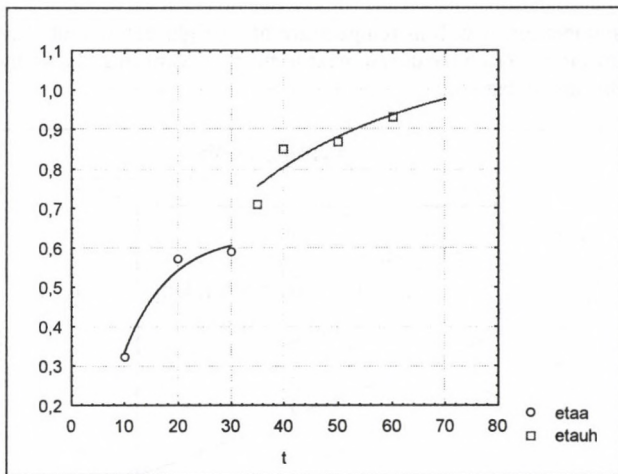

Fig. 3 Efficiency of soaking and ultrasound cleaning (30s soaking and 30s ultrasound)

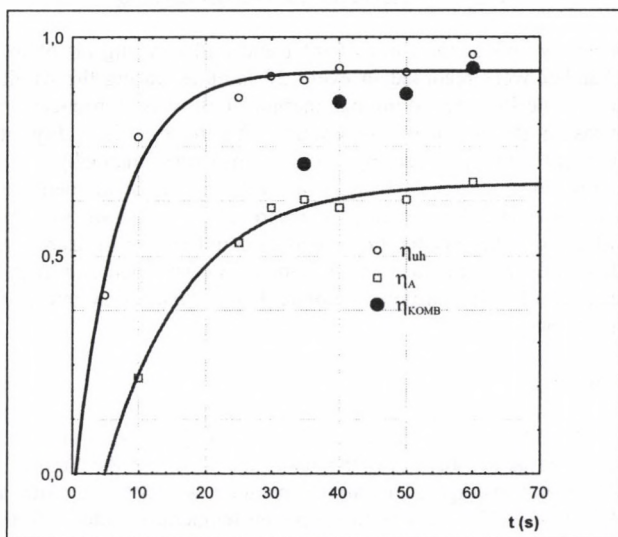

Fig. 4 Comparison of figure 1 and figure 3

The second experiment series showed that the efficiency of the soaking and ultrasound cleaning increased linearly with increasing temperature of solvent. The advantageous temperature region of the ultrasound and the soaking cleaning and solving effect of the solvent falls into the same region (55-65°C) (Figure 2).

It can be seen from the third experiment series that similar high cleaning efficiency can be reached when the soaking cleaning is combined with the ultrasound after the half of the operation time (30s).

## Conclusions

### Summarising the results of the experiments it can be stated:

- The efficiency of the cleaning showed an exponential curve approximating a maximum value if we consider the solvent property and concentration as constant and holding the time and temperature within a definite limits.
- The strongly adhering contamination, e.g. dried milk, can be removed from the plastic material in a measure of 90% applying low concentration of solvent (1% NaOH) and ultrasound for 50-60 s.
- The results of cleaning in two stages gave useful information for transferring the results into the industrial application. The time of the intensive cleaning operation demanding high energy usage can be reduced by the properly chosen soaking cycle significantly.

## References

- [1] Edelmeyer, H.: Theorie der Reinigung und Defektion. Fleischwirtschaft, 1980., p. 352-361.
- [2] Fernandez, J. B., Schmidt, u: Theorie der Hochdruckreinigung. Fleischwirtschaft 1983. p. 1038-1041.
- [3] Diggelmann, W.: Reinigung mit Hochdruck wasserstrahl. Ernährungsindustrie, 1981., 3. sz. p. 60-61.
- [4] Ottó Tuchenhagen GMBH und Co KG. Waschmaschinen für Fleischindustrie Bulletin Hamburg 1983.
- [5] Unikon A. I. WAG.: Allzweck – waschmaschinen. Bulletin Harde/Holland, 1979.
- [6] Stic-Hafroy Co.: Plastic vat and container washing machine. Emballages 1976. 338. sz. p. 251-252.
- [7] Ernst, Göbel KG Maschinenfabrik: Élelmiszeripari tároló és szállítóeszközök tisztítása és berendezései. Előadás. Szimpozium Budapest. 1983.
- [8] Mezőgépi Cserkút: AK 3a Ládamosógép Műszaki Ismeretető 1982. (In Hungarian)
- [9] Neppiras, E. A.: Acoustic cavitation. Physics Report. 1980. 61 k, p. 159-251.
- [10] Tarnóczy T.: Ultrahangok (Ultrasound). Műszaki Könyvkiadó, Budapest, 1972. (in Hungarian)
- [11] Techno Pack Ltd.: New ultrasonic crate washing system. Dairy Industries International, 1977. Nov., p. 14-15.
- [12] Ordini, S. V.: Kontinuierliche ultraschall-reinigung Chemie Anlagen und Verfahren. 1979. p. 108.
- [13] Wolf, G.: Ultraschall zur Packmittelreinigung. Packung und Transport in der Chem. Ind. 1976. 3., 460-462.
- [14] Forgács, E., Korányi, M., Szabó, G. (1994): Tisztítási technológia eljárás-paramétereinek optimalizálási lehetőségei. Élelmiszeripari Főiskola, Tudományos Közlemények, 17. pp. 85-93.

# STUDY ON TEMPERATURE AND MOISTURE DISTRIBUTION INSIDE THE BATCH OF CONVECTIVE CORNCOB DRYER

J. Beke – G. Bihercz – Z. Kurják  
Szent István University, Gödöllő

## Introduction

Convective drying is one of the most favored drying methods of drying industry because of its simple build-up and relative low investment cost. However, the high improvement of the convective drying technology (enrichment of quality and quantity of drying product) may causes difficulties of drying process, especially in the seed production. We aimed to measure the temperature and moisture distribution inside a batch type modern convective corncob dryer. A unique measurement system has been prepared for this purpose and a huge level data acquisition has got a special chance to draw down some meaningful conclusions.

## Measurement Method

The corncob dryer itself is a huge automated building with several doses of drying chambers in two lines along the building. The chambers are vertically aerated with drying air of about 40°C temperature and approximately 100,000 m<sup>3</sup>/h/chamber. Each chamber contains about 50 tons of drying ear of corn (Celest 1464939).

The drying air is blown through a channel (Figure 1.), where its temperature and velocity were measured. Eight measurement sections were chosen divided into 3 lines and 6 columns and line/column sections were designated as measurement points. Measurements have been carried out by ALMEMO type measurement equipment for measuring of temperature, velocity as well as relative humidity of drying air. Air pressure has been measured by U-type manometer where reference pressure has been approached from an appropriate far point of drying range. In order to take samples from the drying product a special sampling tunnel was prepared and installed in the centre of the batches (Figure 2.). Each sampling tunnel was mounted with 6 manual sampling windows through which the samples were taken at predefined time intervals. The moisture content of samples was determined by means of standard a convective oven.

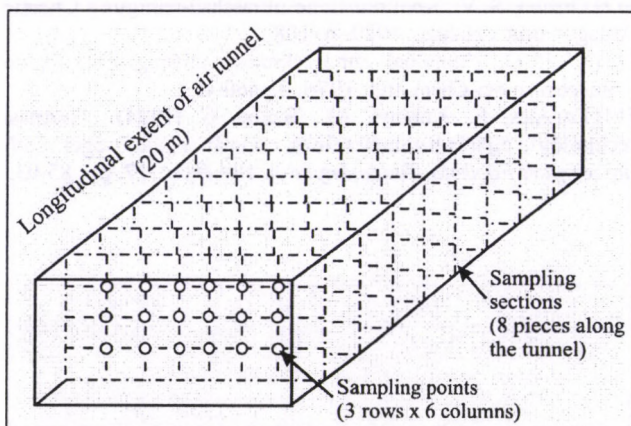

Fig. 1 Measurement points within the tunnel of drying air

Each sampling window contained 2 pieces of Fe-Ko thermocouples sunken in the batch and in the cob, in this way batch and material temperature at the level of each sampling window were measured. Temperature values have been recorded with JUMO type data acquisition system (sampling time was set 15 minutes). Moreover temperature values of

ambient air as well as temperature of air right before and after the air heater unit and right next to the fan has been gathered by this instrument, too.

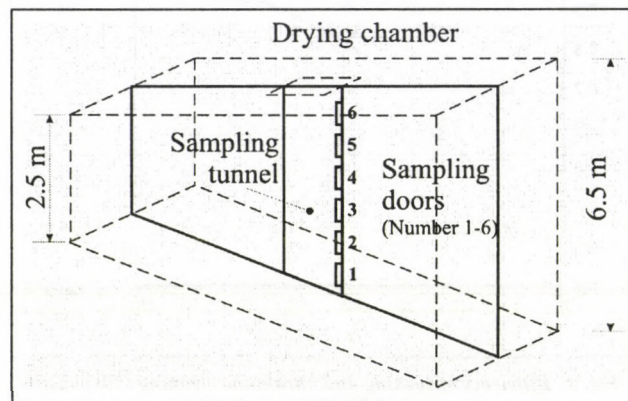

Fig. 2 Special tunnel for material sampling

Velocity and temperature of inlet and outlet drying air of the chamber were recorded in every 30 minutes during the whole drying period. An additional thermocouple was introduced to measure the ambient temperature. The relative humidity of ambient and outlet drying air was measured manually. The temperature values of batches as well as that of ambient air were recorded by a central measurement acquisition system. Inlet and outlet drying air properties could not be measured in this static way because of permanent by-pass open and close; therefore for this purpose a mobile data acquisition system was developed.

## Results

First of all the temperature of inlet and output drying air were recorded as a function of the residence time. As the Figure 3 shows the average input air temperature was 39.3 °C with a deviation of ±2 °C while the output air temperature altered from 20 to 35 °C.

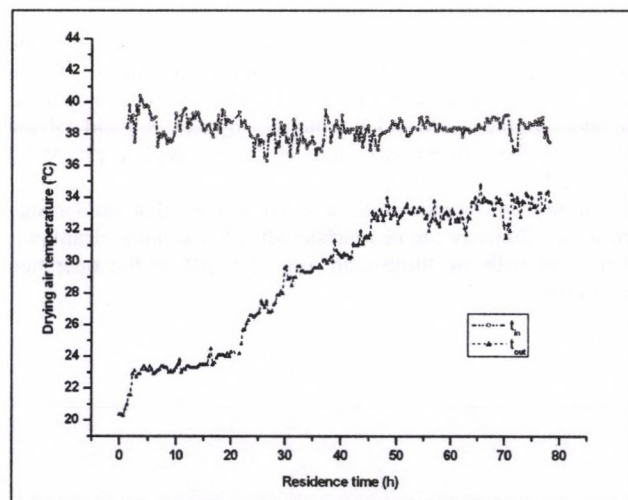

Fig. 3 Integrated temperature of the input and the output drying air as a function of the residence time

On the basis of the recorded data the temperature distribution of drying air was calculated corresponding to the input and output cross sections of the drying chamber. The input heat map was quite homogeneous (Figure 4) but the output temperature distribution showed significant deviations as functions of places (Figure 5) because of the inhomogeneous batch porosity and output air flow distribution.

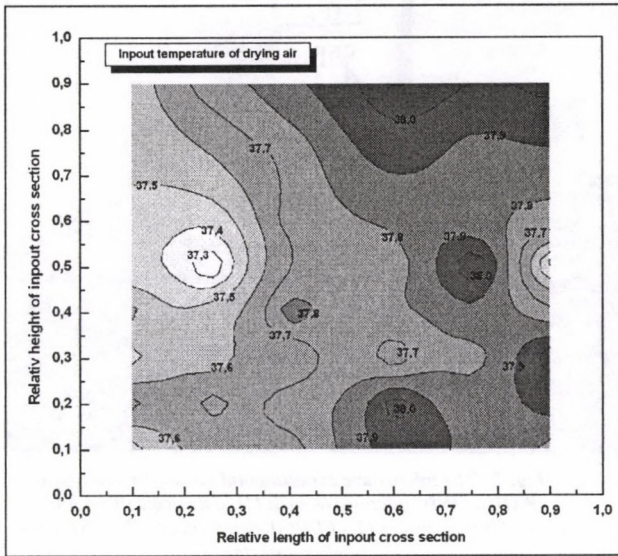

Fig. 4 The typical heat map of the input drying air

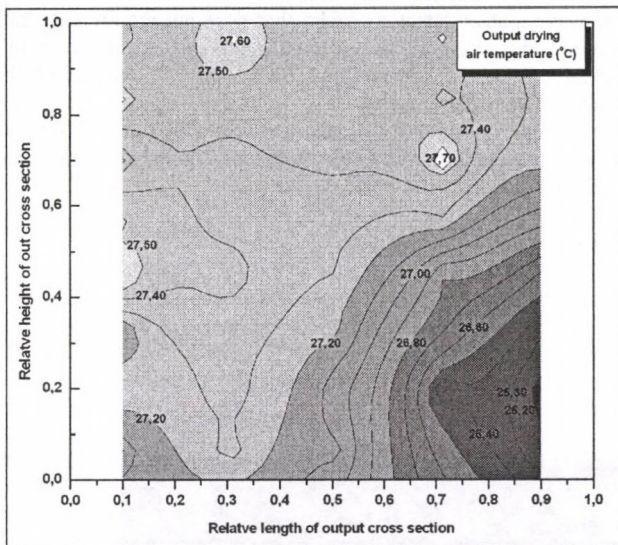

Fig. 5 The characteristic temperature distribution of the output drying air

The moisture distribution (Figure 6) moreover the temperature distribution (Figure 7) of drying material proved that the drying technology needs a major improvement in these aspects. The material rewetting that takes place at the beginning of the drying process increases the needed residence time. The non-homogeneous heat map allows us to think that the material – especially in the under 1/3 of the layer depth and at the end of the drying process will be overdried. This presumption is underlined by the 2D kinetic curves (Figure 8). As it can be seen after 75 hours the total layer depth dries under a moisture content of 12% in wet basis, more over the half of the drying material reach this water content after 60 hours.

### Conclusions

The inhomogeneous airflow rate distribution in the drying chambers causes an undesired temperature and moisture map inside the batch. Thus, there are significant differences in the moisture content of the out-loaded material.

The oversaturated drying air may cause local rewetted periods in the drying material as a consequence of the applied drying technology. By increasing a 10% in air flow rate would cease this undesired phenomenon.

By defining the topical relationship between the air temperature and the moisture content of the drying material during drying an economical drying technology of corn ears can be developed.

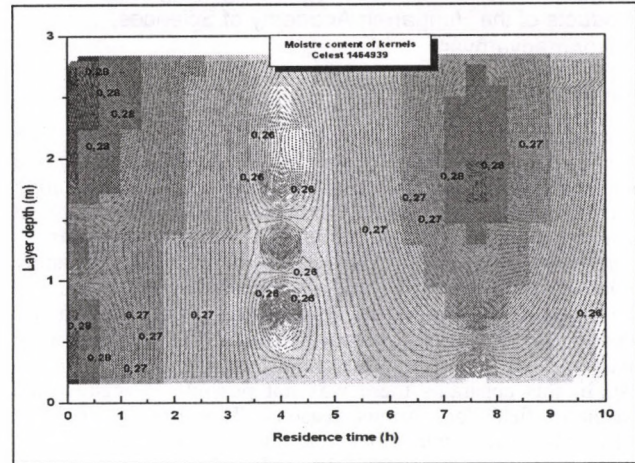

Fig. 6 Moisture distribution of drying material as functions of drying time and layer depth

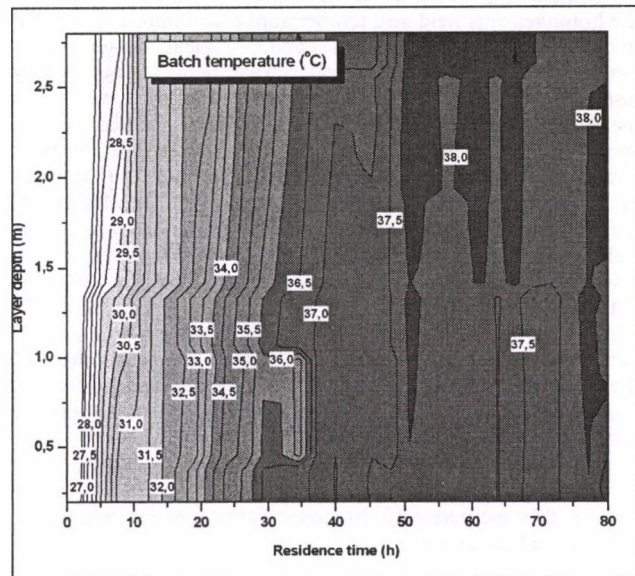

Fig. 7 Material temperature distribution as functions of layer depth and drying time

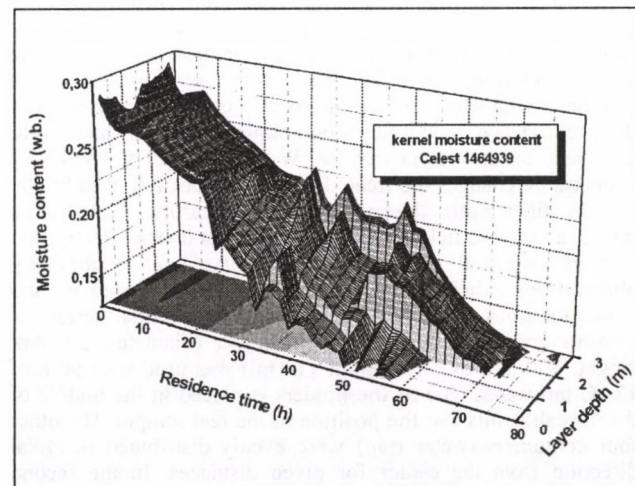

Fig. 8 Kinetic curve of corn ears corresponding to the required end moisture content of 12% at wet basis

## HOMOGENIOUS MICROWAVE FIELD CREATION

E. Lakatos<sup>1</sup> – A.J.Kovács<sup>1</sup> – M. Neményi<sup>2</sup>

<sup>1</sup>University of West Hungary, Mosonmagyaróvár

<sup>2</sup>Research Group Process Engineering of Agricultural Products of the Hungarian Academy of Sciences, Mosonmagyaróvár

### Introduction

Microwave treatments are very common in various food processes such as drying, pasteurization, cooking and enzyme activation [1]. Almost all the time a problem occurs during microwave treatments, namely that the energy (and consequent temperature) distribution inside the radiated materials is significantly uneven [2]. The results of treatments are hardly reliable by this non-homogeneous temperature distribution. At the Institute of Biosystems Engineering preliminary studies were carried out using an own-built experimental microwave oven in connection to temperature distribution of treated liquids [3]. In this apparatus there was not possible to regulate the magnetic field for various reasons. Therefore, a domestic microwave oven with fiber optic thermometer system was installed for microwave researches of liquid foodstuffs.

In this research our objective was to create homogeneous microwave field inside and around the sample holder. In microwave experiments this ought to be the first activity all the time since the homogeneous field and temperature distributions are crucial in detection of physical, chemical and biological changes.

Temperature measurements in microwave fields are not an easy task. Thermometers containing metal parts cannot be used to measure temperature inside microwave fields because of the specific characteristics of microwave. Attempts to measure temperature were made by thermometers [4] and shielded thermocouples [5] with more or less success. The most accepted method for temperature measurements inside the microwave field is the fiberoptic thermometry [6]. Infrared thermography is also an extensively used common method to study heating patterns in microwave product and process development [7]. During our measurements a ThermoCAM system was used to detect temperature distribution and create temperature maps of the microwave treated liquids. The "determination" of homogeneous microwave field was primarily based on the results of thermo graphic images.

The dielectric constant of water is very high, therefore water can store the electric field energy [8]. Water was used as energy trap in this measurement to create homogeneous microwave field around the samples.

### Materials and methods

A PANASONIC NNF 653 WF type domestic microwave oven with a FISO MWS-4 fiber optic thermometer was used for microwave treatments (Fig.1). The power was continuously emitted by the inverter type oven (in contrast to most of the commercial ovens where the microwave power is pulsed). The treatment parameters were adjusted by a computer connected to the oven. Hence, individual programming could be carried out. The basic set-up was, power 100 W for 25 minutes. The inside temperature changes the treated materials were followed by the in-built fiber optic thermometer that measures temperature inside microwave field based on Fabry-Perot interferometry [6]. The experimental set-up was made based on preliminary observations, where single sample holder was heated up and inhomogeneous field was obvious. In the first series of measurements five Teflon sample holder (diameter: 38 mm, height: 100 mm of each, about 113 ml) was used with 90 g of 12 °C tap water. One of the holders is placed in the middle of the turntable, this was the position of the real sample. The other four containers (water trap) were evenly distributed in radial direction from the center for given distances. In the second series of experiments the real sample holder was replaced with the diameters of 85 mm and heights of 60 mm (about 340 ml) Teflon container, holding 200 g of 12 °C of distilled water or skimmed milk.

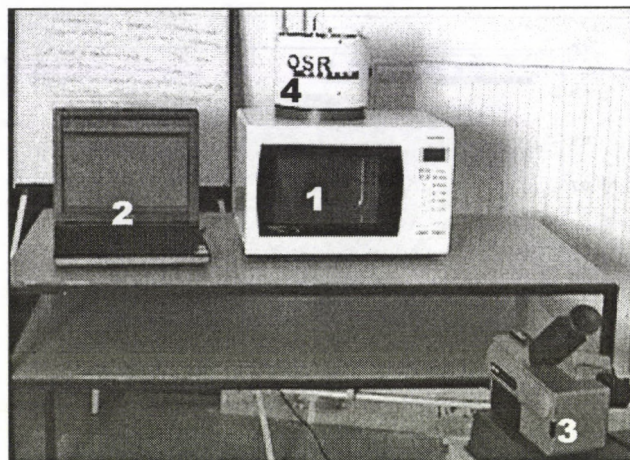

Fig. 1 The microwave experimental set-up. Inverter type PANASONIC microwave oven (1), data acquisition and controlling computer (2), FLIR thermo camera (3), OSR fiber optic thermometer (4)

The infrared images were made by a FLIR PM675 type longwave matrix detector camera that does not require external cooling. This camera allows of continuous image acquisition by instant capturing. ThermoCam 2000 software was used to evaluate the infrared images.

During the experiments we examined the shape (sizes) effect of sample holder the positions of water load containers in order to get homogeneous field inside the cavity.

### Results

Figure 2 shows the thermographic images of single sample holders placed alone in the oven. The temperature differences inside the sample in Fig. 2A is 18.9 °C while in Fig. 2B is 5.2 °C. These clearly indicate the inhomogeneity of the electromagnetic field.

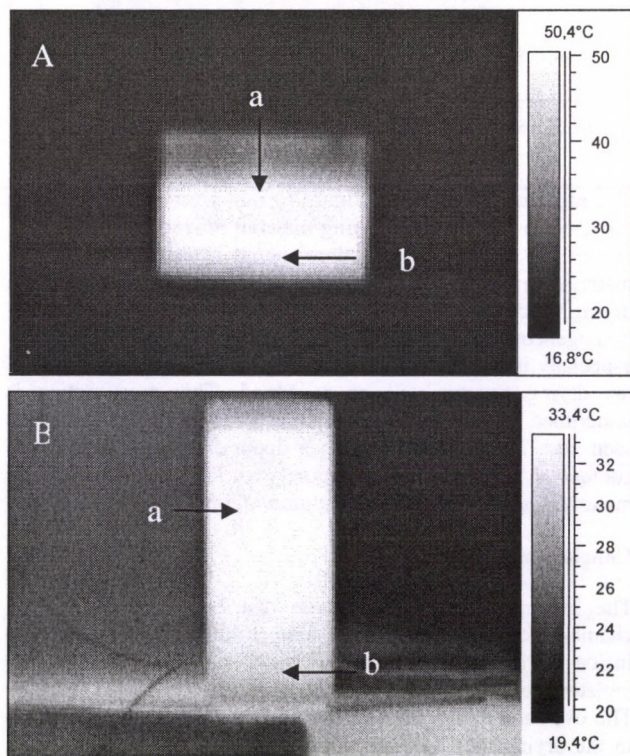

Fig. 2 Temperature maps of single sample holders placed alone in the microwave oven. 2A: 340 ml container, a = 51.9 °C, b = 33.1 °C. 2B: 113 ml container, a = 33.9 °C, b = 28.7 °C.

The water trap containers absorb most of the radiated energy, by means of heating up the water inside the four containers from 12 °C to 75-80 °C. In this case the liquid material inside the real sample holder in the center of turntable warms up only  $45 \pm 2$  °C. Homogeneous temperature distribution was not achieved at all in the case where the five containers had the same geometry (first series of measurements) regardless of the positions of water load containers. The top of the liquid in the real sample holder was all the time warmer than its bottom region (container on the right hand side of Fig. 3). The temperature difference was 9.2 °C in this case.

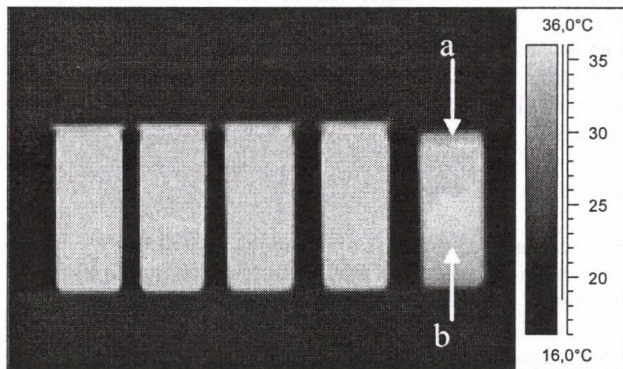

Fig. 3 Thermographic image of the water load (four containers on the left) and the sample holder  $a = 37$  °C,  $b = 27.7$  °C

In the second series of experiments the 340 ml real sample holder was used in the middle (Fig. 4). Figure 5 shows the first of this kind of experiments where water was used as sample material. The most even temperature distribution was gained if the water load containers were positioned 3 cm from the center of turntable.

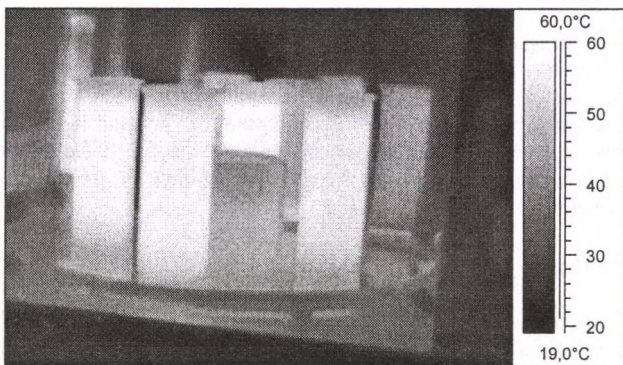

Fig. 4 The placement of the containers inside the microwave oven, thermographic image

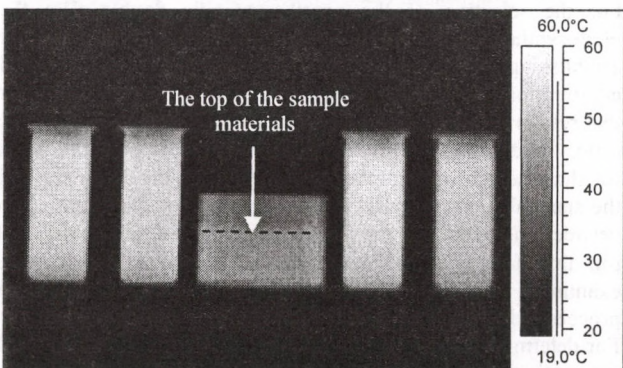

Fig. 5 Infrared image of the containers, water was used as the sample material

In the case where the sample container contained milk the water load containers had to be placed 5 cm from center (Fig. 6).

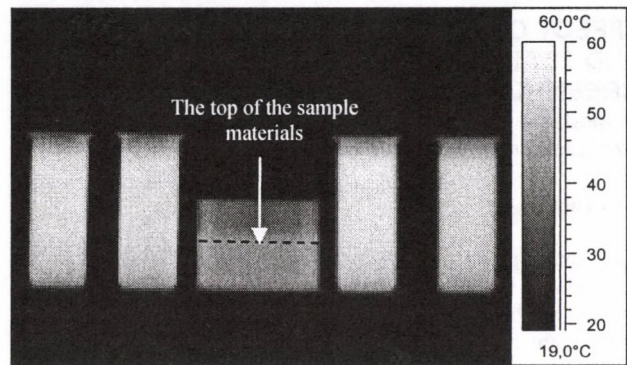

Fig. 6 Infrared image of the containers, skimmed milk was used as the sample material

The maximal temperature difference inside the real sample holder (the middle container on the images) was 2.6 °C in the second set of measurements. This was considered to show very accurate homogeneous microwave field strength distribution.

### Conclusion

Major temperature differences occur during microwave treatments inside the heated materials. One of the main reasons of this is that the field strength distribution inside the cavity is uneven. This is because of that cavities are tuned when they are empty. If any material is placed in the oven the evenly tuned field strength distribution alters and causes temperature differences inside the material. For exact microwave measurements (and also treatments) homogeneous strength distribution has to be created at least around the sample holder. Placing water load containers around the sample homogeneous field can be created that is detectable by equal material warm up. However, care must be taken to select the shape and position accurately of the water load containers that is also determined by the quantity and quality of the treated materials. In optimal case the maximum temperature difference inside the sample rises only 2.6 °C.

### Acknowledgement

This research was funded by the Hungarian Scientific Research Fund (OTKA): T17 49700 and T17 63218.

### References

- [1] Kiranoudis C.T., Tsami E., Maroulis Z.B. Microwave vacuum drying kinetics of some fruits. *Drying Technology*. 1997. 15(10). pp. 2421-2440.
- [2] Neményi M., Lakatos E., Kovács A.J. Mikrohullám kezelés használata nyers és fogyasztói tej zsírtartalmának meghatározására. MTA-AMB, 30. Kutatási-Fejlesztési Tanácskozás, Gödöllő (30th R&D Conference of the HAS-Agricultural Engineering Committee) 2006.
- [3] Neményi M., Lakatos E., Kovács A.J., Kacz K., Stépán, Zs. Különböző zsírtartalmú tejek mikrohullámú kezelése. VI. Nemzetközi Élelmiszertudományi Konferencia, (Conference of 4th International Food Science). 2004. Szeged. 20-21 April. pp. 104-105.
- [4] Villamiel M., delCastillo D., San Martín, C., Corzo N. Assessment of the thermal treatment of orange juice during continuous microwave and conventional heating. *J Sci Food Agric*. 1998. 78. pp. 196-200.
- [5] Ramaswamy H., van-de Voort F.R., Raghavan G.S.V., Lightfoot D., Tibbers G. Feed-back temperature control system for microwave ovens using a shielded thermocouple. *Journal of Food Science*. 1991. 56(2). pp. 550-552, 555.
- [6] Datta, A.K.; Anantheswaran, R.C. *Handbook of Microwave Technology for Food Applications*. Marcel Dekker, Inc., New York. 2001.
- [7] Bows J., Joshi K. Infrared imaging feels the heat in microwave ovens. *Physics World*. 1992. 5(8). pp. 21-22.
- [8] Géczy G. Összefüggések mezőgazdasági termények dielektromos jellemzőinek meghatározására. *Mezőgazdasági Technika*. 2002. April. pp. 2-4.

# EFFECT OF ADDITIVES ON TRANSMISSIVITY AND TEARING STRENGTH OF THE GREENHOUSE COVERING PLASTIC FILMS

V. Madár – M. Szabó – E. Judák  
Szent István University, Gödöllő

## Abstract

The double plastic film covered block greenhouses are the new products of the last 10 years and their speedy development is assured by the cheap plastic films. The main disadvantage is the lower light transparency than glass and because of the double using for the better insulation the light transparency is much more reduced. In most of the cases the type of the inner and outer layer is the same which is not the best solution for the spectral transmissivity from the plants point of view.

The basic material of agricultural covering plastic films for greenhouses is Polyethylene (PE). The basic additive is the UV-absorption additive for ensuring the UV stability and other additives for the stability which brake the degradation due to oxygen, improve a resistance of the plastic film against chemicals. It is important for the span of life of the plastic.

The aim of the research is to find out such an adequate coupling of film layer which provide an advantageous spectrum from energetic, physiological and forcing point of view and in such a way that the selected couple of film layer can fulfill the stress requirements coming from the different forming of greenhouse structure.

It is essential to take the advantage of that the inner film can content as low amount of UV additives as possible because the inner film is protected from UV radiation and the termofol effect is also not important if the outer film contains it already. After measurements and the two year long practice verify that during the selection of the inner PE film in greenhouse covering the UV additive can be disregarded and due to this the incoming radiation can be increased. At the selection of the inner film - in case if it is a Polyethylene - the thickness will be determined first by the load of the film and the spectrale transmissivity only secondly can be taken into consideration.

The research was supported by the National Science Fund of Hungary (OTKAF046478).

KEYWORDS: greenhouse covering plastic film, additives, spectral distribution, tearing strength

## Introduction

In the forcing vegetable production at a european dimension the role of Hungary should not be neglected due to the considerable amount of the paprika (capsicum), tomato, cucumber and the other sorts of vegetable produced to the internal and european market, arising from the good climate condition. So the economy of production is basicaly influenced by the favourable heating facilities due to the prosperous number of sunshine hours and adequate average temperature. The blockssystem greenhouses with double plastic covering can afford the ideal way in the hungarian circumstances and options nowadays when the standard of the investment and the acquisition costs are in harmony with the demand and profitableness of vegetable forcing.

The double plastic film covered block greenhouses are the new products of the last 10 years and their speedy development is assured by the cheap plastic films. This type of greenhouses can even reach the standard of the production in glasshouses. Their specifics are the easy automation, the quick siting, they have good resitation to the environmental effects and their insulation is much better because of the air layer between the double film sheets and because of using thermofolies. The main disadvantage is the lower light transparency than glass and

because of the double using for the better insulation the light transparency is much more reduced. In the early period of a plant the reduced light can result lower quality and amount of plant (in the case of paprika i.e. the Vitamine C amount is much lower, the standard deviation of the form and size wich is characteristic to the species is higher.) It is well known that 1 % of light increase increases the production by 1 %.

The basic material of agricultural covering plastic films for greenhouses is Polyethylene (PE). The basic additive is the UV-absorption additive for ensuring the UV stability and other additives for the stability which brake the degradation due to oxygen, improve a resistance of the plastic film against chemicals. It is important for the span of life of the plastic. The amount of the additives determines how long can be used the film with a 95 % safety. The other main part of the additives are the mineral ingredients (i.e. chalk) for different thermo effect purposes.

## Aim of the research

The resultant transmittance of the double film can be given with the product of the spectral transmittance of the two layer.

In most of the cases the type of the inner and outer layer is the same which is not the best solution for the spectral transmissivity from the plants point of view.

For the selection of the outer covering film of the greenhouse it has to be taken into consideration:

- It has to be the best transparency for PAR
- with UV additives
- good mechanical characteristics
- good thermic characteristics (greenhouse effect)

For the selection of the inner layer it can be considered that there is no outer last because of wind and snow, and the UV radiation is filtered by the outer layer, so the maximal transmittance has the biggest role.

The aim of the research is to find out such an adequate coupling of film layer which provide an advantageous spectrum from energetic, physiological and forcing point of view and in such a way that the selected couple of film layer can fulfill the stress requirements coming from the different forming of greenhouse structure.

## Method

The greenhouse for this research was built in 2003 and the third forcing period has been started already. The inner film is intact, there was no degradation on it and so a non UV-stable film can be used as inner film when the UV absorption of the outer film is suitable.

For the selection of the paprika specific double film the photosynthetic activity of the plant has to be known. For establishing the resultant spectral transmissivity the effect of additives on the spectral transmissivity has to be measured. For that reason three example in different thickness used in practice (100, 150 and 200  $\mu\text{m}$ ) of the clear PE film has been produced for the research of the relationship between the thickness and the spectral transmissivity. For the research of the relationship between the additives and the transmissivity 4 films with 170  $\mu\text{m}$  thickness with different type of known additives were examined. The applied measurements for the research were proceeded in two fields:

For determining the transmitted spectrum there have been used automatic spectrophotometers:

- for the visible spectrum (200-900 nm) Jasco UV, visible V550 two port equipment
- in the spectrum of 666-2000 nm Bruker IFS 66 V/5 NIR spectrophotometer

- 1428-25000 nm Jasco FTIR 300 E infrared spectroscopy with Fourier transformation.

For completing the tensile strength test after the MSZ-EN-ISO 527-1:1999 norm with Instron tensile-strength testing instrument. The width of examples was 50 mm, the initial load was 5 N, the feed 25 mm/min and the distance between the bites was 100 mm.

## Results

Fig. 1. shows the relationship between the thickness and spectrale transmissivity in the case of clear PE examples. In the field I. of the Photosynthese (440 nm) between the films with the thickness of 100 and 200  $\mu\text{m}$  the difference is 4-5 % and between the two of 150 and 200  $\mu\text{m}$  only 1-2 % which can be a result of the inaccuracy of measurements.

In the tensile-test diagram in the Figure 2. can be seen that the thickness of the film and the power regarding to the flowing strength shows a linear proportionality in the case of the thickness of 100 and 200  $\mu\text{m}$ . From the settings of the blown filmproducing the extension after the extruder influences the tear resistance. It explains that the 150  $\mu\text{m}$  film shows no linear relationship. Therefore repeated measurements are required with fixed expansion parameters.

In the case of the films with different additives the comparison level is the 150  $\mu\text{m}$  clear PE film. As shown in the Figure 3. as an effect of the UV additives the transmissivity in the I. field photosynthesis is reduced by 5-15 %. It is reduced in addition by the termofol additives extremely up to by 55 % as a result of the S2NH(yr) max 77580 additive. Therefore it is essential to take the advantage of that the inner film can content as low amount of UV additives as possible because the inner film is protected from UV radiation and the termofol effect is also not important if the outer film contains it already.

Fig. 4. shows the relationship between the additives and the tensile strength. The film with S2NH additive has no flow limit and the flexible stage is also significantly shorter.

## Conclusions

After measurements and the two year long practice verify that during the selection of the inner PE film in greenhouse covering the UV additive can be disregarded and due to this the incoming radiation can be increased.

At the selection of the inner film - in case if it is a Polyethylene - the thickness will be determined first by the load of the film and the spectrale transmissivity only secondly can be taken into consideration.

Due to that recognition that the resultant transmissivity can be given as the product of the transmittance of the double film layer the variety of the two layer with different additives makes possible producing a plant specific spectrum and optimizig the energetic characteristic of greenhouse covering.

## References

- [1] Szabó M. - Barótfi. I.: 1998. Effect of greenhouse covering materials on developing light circumstances. Bulletin of the University of Agricultural Sciences Gödöllő.
- [2] Szabó M.: 2001. Examination of parameters generating light reduction in greenhouses. In: Hungarian Agricultural Engineering, 2000/13. sz. p. 84.
- [3] Balázs Sándor: A zöldségajtatás kézikönyve, Mezőgazda Kiadó, 2000
- [4] MTA Központi Kémiai Kutató Intézet: Növényvédőszerk hatása a kertészeti fóliák élettartamára, Polimer Fizikai-Kémiai Osztály, Budapest, 1997

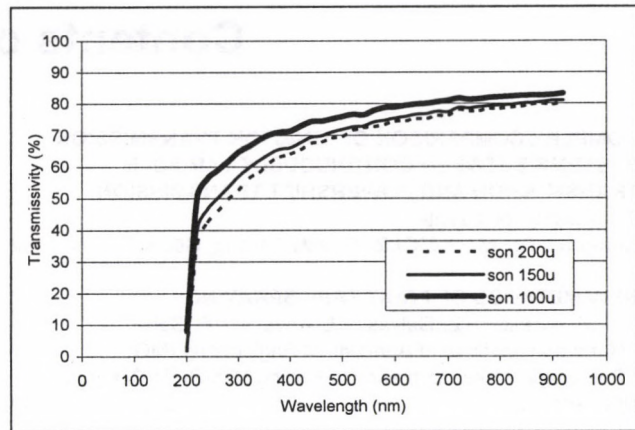

Fig. 1 The spectrale transmissivity in the dependence of thickness

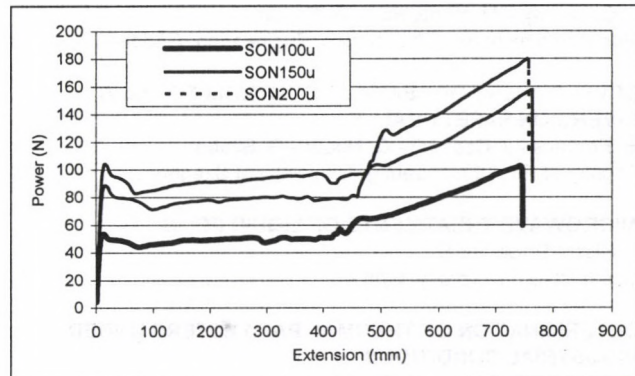

Fig. 2 Tensile-test diagram in the dependence of thickness

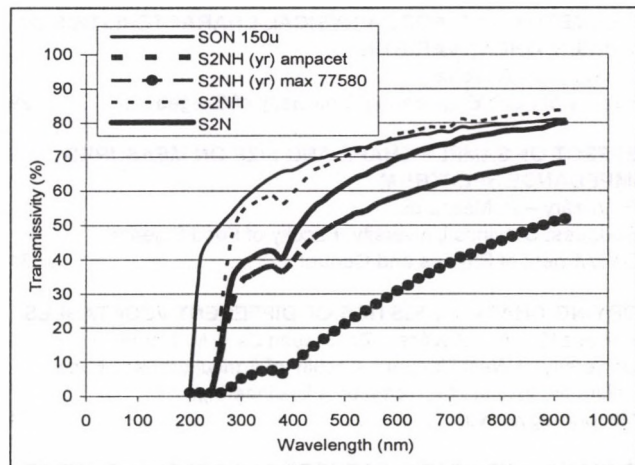

Fig. 3 The spectrale transmissivity in the dependence of the type of additives

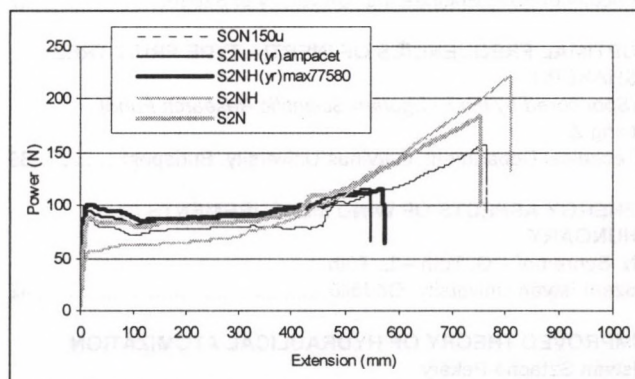

Fig. 4 Tensile-test diagram in the dependence of the type of additives

# Contents of N° 18/2005

<b>COMPLEX COMPARISON OF TRACTOR TRANSMISSION SYSTEMS BETWEEN CONTINUOUSLY VARIABLE TRANSMISSION AND POWERSHIFT TRANSMISSION</b> Zs. Kassai – M. Sente Non-profit Co. of the MGI for Quality Testing, Gödöllő.....	<b>NEW METHODS FOR THE EVALUATION OF HYDRO MOTORS</b> S. Török – Z. Bártfai Szent István University, Gödöllő.....
12	48
<b>NEW METHODS OF FRUIT TREE SPRAYING</b> Gy. Dimitrievits <sup>1</sup> – Z. Gulyás <sup>1</sup> – L. Kovács <sup>1</sup> – P. Sallai <sup>2</sup> <sup>1</sup> Hungarian Institute of Agricultural Engineering (MGI) <sup>2</sup> Pomological Research and Consulting Non-Profit Company, Újfehértó.....	<b>RELATIONSHIP BETWEEN FARM SIZE AND MECHANIZATION</b> J. Hajdú – L. Gockler Hungarian Institute of Agricultural Engineering, Gödöllő.....
15	50
<b>EFFECT OF THE DRYING PROCESS ON THE CHARACTERISTICS OF THE CORN BATCHES</b> J. Csemely – M. Herdovics – A. Csátár Hungarian Institute of Agricultural Engineering, Gödöllő.....	<b>ECONOMIC ANALYSIS OF MECHANIZATION TECHNOLOGY OF FIELD VEGETABLE PRODUCTION</b> L. Magó – F. Jakovác Hungarian Institute of Agricultural Engineering, Gödöllő.....
18	55
<b>DEVELOPMENT OF LEAKAGE CONTROLLED FLOW DIVERSION SAFETY VALVE</b> E. Forgács - J. Csanádi - C. Hodúr - G. Szabó Faculty of Food Engineering, University of Szeged.....	<b>EFFECT OF NUTRIENT SUPPLY ON THE VALUE OF FIELDS IN HUNGARY</b> Z. Peszeki – Zs. Szentpétery – I. Kovács Szent István University, Gödöllő.....
20	59
<b>MICROWAVE TREATMENTS OF LIQUID FOOD</b> J. Kiss – P. Sembery Szent István University, Gödöllő.....	<b>THE ROLE OF EXTENSION IN THE TECHNICAL IMPROVEMENT OF AGRICULTURAL ENTERPRISES</b> K. Tóth – J. Bárczi – Cs. Fogarassy Szent István University, Gödöllő.....
23	61
<b>DETERMINATION OF THERMAL PARAMETERS UNDER INDUSTRIAL CONDITIONS</b> F. Eszes – R. Rajkó – G. Szabó Faculty of Food Engineering, University of Szeged.....	<b>EXPERIMENTAL DEFINITION OF THE PRIMARY FORCE OF STUMP</b> E. Horváth-Szováti – I. Czupy University of West Hungary, Sopron.....
26	64
<b>GEOMETRIC AND AGRO-PHYSICAL CHARACTERISTICS OF WINTER WHEAT VARIETIES</b> E. Gyimes – A. Véha Faculty of Food Engineering, University of Szeged.....	<b>MEASUREMENT OF FOREST ROAD BY GPS</b> J. Péterfalvi – G. Markó University of West Hungary, Sopron.....
29	67
<b>EFFECT OF SAMPLE SHAPE AND SIZE ON MEASURED IMPEDANCE SPECTRUM</b> E. Vozáry – P. Mészáros Budapest Corvinus University, Faculty of Food Science, Department of Physics and Control.....	<b>EFFECT OF MOISTURE CONTENT CHANGE ON COLOUR CHARACTERISTICS OF PAPRIKA POWDER</b> Zs. H. Horváth – A. Véha Faculty of Food Engineering, University of Szeged.....
31	69
<b>DRYING CHARACTERISTICS OF DIFFERENT VEGETABLES</b> K. Kacz K. – A.J. Kovács – Zs. Stépán Zs. – M. Neményi University of West Hungary, Faculty of Agricultural and Food Sciences, Institute for Biosystems Engineering, Mosonmagyaróvár.....	<b>MEASUREMENT ASSEMBLY FOR ENERGETIC ANALYSIS OF COMMINTERS</b> P. Korzenszky – E. Judák Szent István University, Gödöllő.....
34	72
<b>DYNAMIC AND STATIC METHODS OF KERNEL HARDNESS MEASUREMENT</b> A. Véha – E. Gyimes – B. Szabó P. Faculty of Food Engineering, University of Szeged.....	<b>APPLICATION OF ULTRASOUND TECHNIQUES IN WASHING PLASTIC BOXES AND CRATES</b> Gy. Mészáros <sup>1</sup> – Z. Csizmazia <sup>2</sup> <sup>1</sup> College of Food Engineering of the University of Szeged. <sup>2</sup> Centre of Agricultural Science University of Debrecen.....
37	75
<b>OPTIMAL FREQUENCIES OF INERTIA TYPE FRUIT TREE SHAKERS</b> (Sponsored by the Hungarian Scientific Research Fund) Láng Z. Technical Department, Corvinus University, Budapest.....	<b>STUDY ON TEMPERATURE AND MOISTURE DISTRIBUTION INSIDE THE BATCH OF CONVECTIVE CORNCOB DRYER</b> J. Beke – G. Bihercz – Z. Kurják Szent István University, Gödöllő.....
39	78
<b>ENERGY ASPECTS OF WIND MEASUREMENTS IN HUNGARY</b> N. Schrempf – G. Tóth – L. Tóth Szent István University, Gödöllő.....	<b>HOMOGENIOUS MICROWAVE FIELD CREATION</b> E. Lakatos <sup>1</sup> – A. J. Kovács <sup>1</sup> – M. Neményi <sup>2</sup> <sup>1</sup> University of West Hungary, Mosonmagyaróvár <sup>2</sup> Research Group Process Engineering of Agricultural Products of the Hungarian Academy of Sciences, Mosonmagyaróvár.....
42	80
<b>IMPROVED THEORY OF HYDRAULICAL ATOMIZATION</b> István Sztachó-Pekáry College of Kecskemét, Kecskemét.....	<b>EFFECT OF ADDITIVES ON TRANSMISSIVITY AND TEARING STRENGTH OF THE GREENHOUSE COVERING PLASTIC FILMS</b> V. Madár – M. Szabó – E. Judák Szent István University, Gödöllő.....
45	82

Contents of the  
**“Mezőgazdasági Technika”**  
 periodical of the year 2005.

**MEZŐGAZDASÁGI**  
**TECHNIKA**

2100 GÖDÖLLŐ, TESSEDIK S.U.4.

**N° 1**

Development of a descent pipe with liquids for measurement of the aerodynamical characteristics of the kernels of fertilizers (Á. GindertKele).....	2
Europe Top 25 The “Imagebarometer” for agricultural manufacturers (J. Hajdú).....	4
The greatest motordeliverers of the agriculture (J. Hajdú).....	12
Solutions of power transmission on tractors II (Zs. Kassai – P. Bánszki).....	19
High performance silomaizeharvesting (Zs. Kelemen).....	35
Regulator systems for airpressure in tires for agriculture and forestry (A. Déry).....	38

**N° 2**

Development and Research Conference at the Faculty for Engineering of the University Szent István (L. Tóth).....	1
Experimental examination of highpressure air cylinders (Zs. Bartus – Sz. Árgyelán).....	4
Solutions of power transmission on tractors – Part III (P. Bánszki – Zs. Kassai).....	23
AGROMEK 2005 (Z. Bellus – A. Horváth).....	36
Current prices for the year 2005, recommended by the Association of Hungarian Contractors in Agricultural Machinery (P. Körmendi).....	40
Operating costs of agricultural machines in 2005 (I. Gockler).....	44

**N° 3**

Mechanical processes of recycling of plastics (Z. Bártfai – I. Szalkai).....	2
Development of drying and storage Technologies of corn (M. Herdovics).....	5
Sugarbeet seeders with single corn dosation (J. Fűzy).....	21
Vogel & Noot – with tradition in the future (Zs. Gazsi).....	34
Equipments and machines for pruning cut (J. Hajdú).....	36
I have renovated an E512 combine harvester (F. Tanczos).....	40

**N° 4**

Measurement of the specific energy demand of the clod crushing through forced breakage (S. Virág).....	2
New world records on agricultural machinery (J. Hajdú).....	6
Singleseeders for corn maize (J. Fűzy).....	25
Professional days of AXIÁL in Lajosmizse (A. Horváth – G. Pálincás).....	40
Novelties of SIMA 2005 in Paris (J. Hajdú).....	43
Novelties of the SAMEDEUTZFAHR group at the exhibition SIMA in Paris (Zs. Kassai).....	50

**N° 5**

Economy of the recycled heat energy at cooling of milk (K. Szabó – A. Lukács – H. Tóthné Heim – T. Takátsy).....	2
Development of drying and storage technologies of corn (Gy. Komka).....	5
Filterequipments for internal combustion motors (V. Varga).....	23
I. Farmer(Mezőgazda)Expo in Hódmezővásárhely (A. Horváth – G. Pálincás).....	38
The possible role of renewable energy resources in Hungary (L. Gockler).....	44

**N° 6**

The cracking of corn comes to the front again (Z. Bellus).....	2
The acceleration of the Hungarian innovation would be wellfounded (I. Husti).....	5
Constructions of combineharvesters (Zs. Kelemen).....	21
The world of combineharvesters 20032005. (J. Hajdú).....	34
Change in performance and costs of agricultural machines (L. Gockler).....	40

**N° 7**

Irrigation control at greenhouse plants with computeraided imageanalysis (L. Font – I. Farkas).....	2
Amazona plant production day in Leipzig (A. Horváth).....	5
Constructions of combineharvesters Part II. (V. Pető – Zs. Kelemen – I. Komlódi).....	21
Tractormarket 2004 in WestEurope (J. Hajdú).....	36
The innovationssystem of the Hungarian Government (I. Husti).....	40

**N° 8**

Halfempirical drying model with extended thickness of layer (G. Bihercz – J. Beke).....	2
Results of the leading manufacturers of agricultural machinery of the world in the year 2004 (J. Hajdú).....	6
Sunflowerharvesting adaptors (J. Fűzy).....	29
KRONEshow in Nemesszalók (J. Hajdú).....	58
The effect of the ageing of agricultural machines on the operation's costs (L. Gockler).....	60

**N° 9**

OMÉK 2005 (A. Horváth – G. Pálincás).....	1
Trailers with driven wheels for agricultural transport (T. Szakács).....	2
Challenger's on the field (J. Hajdú).....	5
Actual questions of corndrying (M. Herdovics).....	16
Conventional ploughs (I. Jóri J.).....	23
When is ploughing beneficial and when wrong for the soil? (M. Birkás).....	32

**N° 10**

A general valid method for the detection of the technical condition of hydraulic pumps (S. Török).....	2
Material saving, environmentally friendly spraying processes (Gy. Dimitrievits).....	21
OMÉK 2005: The Hungarian industry of agricultural machinery at the Exhibition (A. Horváth – G. Pálincás).....	32
When is ploughing benefit and when wrong for the soil? Part 2. (M. Birkás).....	35
Development of machines in the Ukraine (J. Hajdú).....	38
Engineer meeting in Mezőkövesd (A. Horváth).....	42

**N° 11**

The influence of stoking of renewable vegetable combustibles on the viscosity of the Diesel fuel and on the combustion process (M. Zöldy).....	2
Newest results of the Fendtdvelopment (A. Horváth).....	6
The development of the mechanization at animal keeping (L. Tóth).....	14
Technologies, machines and equipments of the pig husbandry (I. Pazsiczki).....	21
OMÉK 2005 – Part III: Novelties of the dealers of agricultural Machines (A. Horváth – G. Pálincás).....	30

**N° 12**

Theory and practice of aerating and mixing of structured agricultural waste waters (L. Bense – A. Szász – P. Szendrő – Gy. Vincze).....	2
Economy of the mechanized technology of the production of field crop crops for fresch marketing and for the canning industry (L. Magó – F. Jakovác).....	14
Dieselfuel injection systems (Zs. Kassai – P. Bánszki).....	21
The gate to Middle and Eastern Europe: Agritechnica 2005 (J. Hajdú – Gy. Tátrai).....	30
The cornharvesters John Deere 9888i STS presented themselves in Mezőkövesd (Gy. Hajmásy – I. Sörös).....	34

Do you want to know more from  
**Hungarian Agriculture Machinery!**

**SEND TMIS ORDER FROM TO:**

The Hungarian Agricultural Machinery Journal  
H-2001 Gödöllő, Tessedik Sámuel u. 4.

**ORDER FORM**

I want order the Hungarian Agriculture Machinery Journal  
from ..... day ..... month 200.....

The subscription fee: 3240 HUF

Name: .....

Adress: .....

Code, City: .....

Country: .....

Date: ..... day ..... month 200.....

.....

signature

