

**HUNGARIAN**

**AGRICULTURAL**

**ENGINEERING**

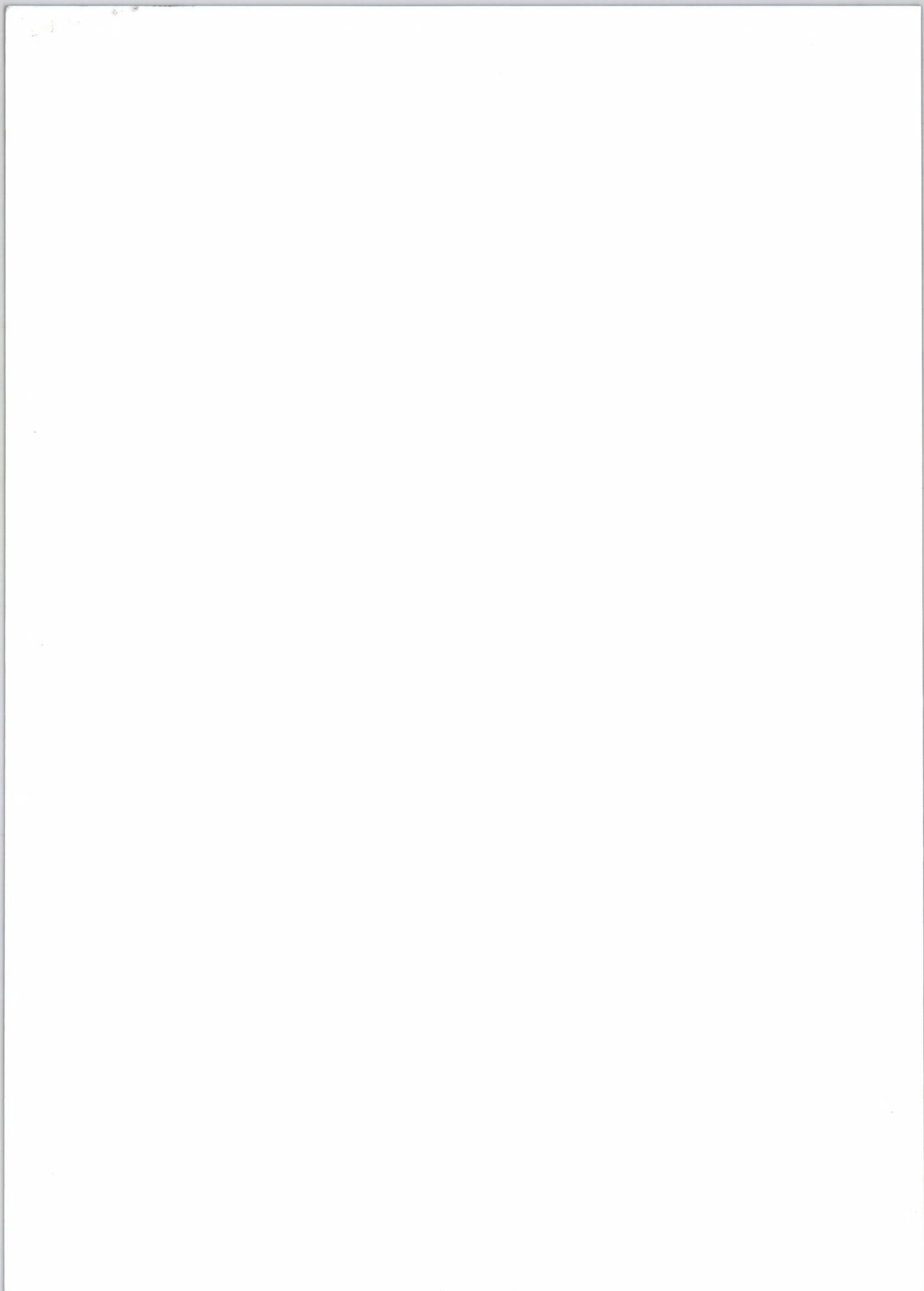





# Hungarian Agricultural Engineering

N° 21/2008

PERIODICAL OF THE COMMITTEE OF  
AGRICULTURAL ENGINEERING OF  
THE  
HUNGARIAN ACADEMY OF SCIENCES

*Editor:*

Prof. Dr. László TÓTH

*Editorial Board:*

Dr. Jenő CSERMELY

Dr. Imre DIMÉNY

Dr. István J. JÓRI

Dr. László FENYVESI

Dr. Péter SEMBERY

Dr. László TÓTH

Dr. János BEKE

Dr. Zdenek PASTOREK,  
*Czech. Republik*

Dr. Jürgen ZASKE,  
*Deutschland*

Dr. Vijaya G.S. RAGHAVAN,  
*Canada*

Dr. Bart SONCK,  
*Belgium*

Published by

**Hungarian Institute of Agricultural Engineering**

H-2100 Gödöllő, Tessedik S. u. 4.

Director: Dr. László FENYVESI



**St. István University, Gödöllő**  
**Faculty of Mechanical Engineering**

H-2103 Gödöllő, Páter K. u. 1.

Dean: Dr. István Szabó



Gödöllő, December, 2008



HU ISSN 0864-7410

Faint text at the bottom of the page, possibly a page number or footer.

## PREFACE

The Agricultural Engineering Board of the Hungarian Academy of Sciences which supervises the development of this branch organises annually a conference at Gödöllő, which is the central place of the Hungarian agricultural scientific activity.

During the sessions, research scientist, developing engineers, experts of institutions engaged in agricultural engineering development strong in numbers the organizer, the hungarian universities and other higher grades of education, the research institutions: Hungarian Institute of Agricultural Engineering at Gödöllő, Faculty of Mechanical Engineering of the St. István University at Gödöllő and foreign guests give account of their results obtained in the research work and development of agricultural machinery.

This yearly English-Language publication the "Hungarian Agricultural Engineering", started at 1988, contains selected papers presented at the conference of 2008. We do hope that this publication will be found interesting to a big part of agricultural engineers.

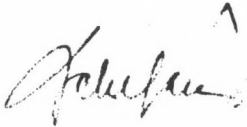

**Dr. István Szabó**  
Dean

Faculty of Mechanical Engineering  
St. István University

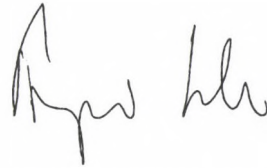

**Dr. László Fenyvesi**  
Director

Hungarian Institute of Agricultural Engineering  
Gödöllő

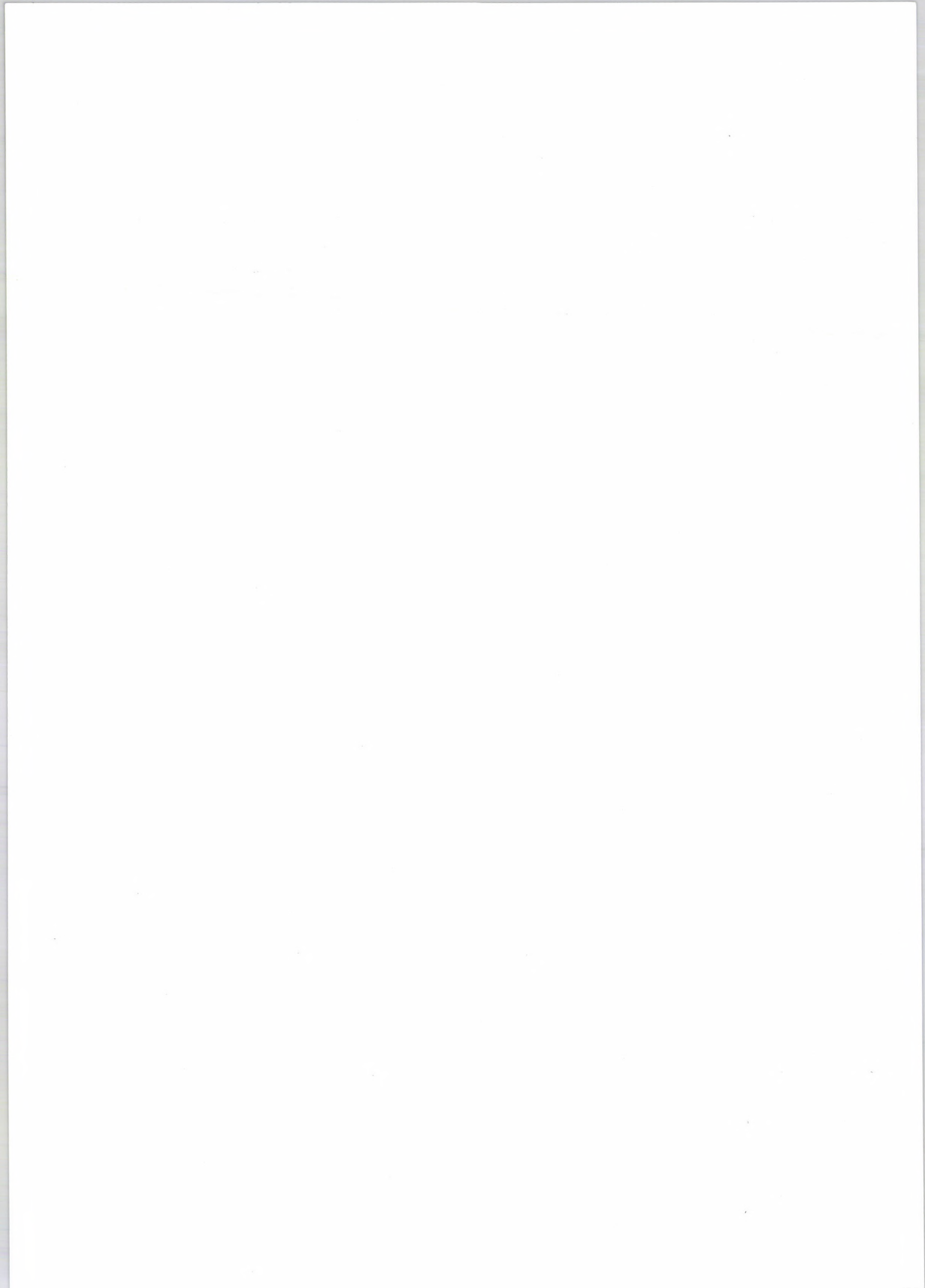

**PART I.**

**ABSTRACT OF SELECTED PAPERS**

## EVALUATION OF THE ACCURACY OF THE AISA DUAL HYPERSPECTRAL SYSTEM IN HUNGARY

József DEÁKVÁRI<sup>1</sup> - László KOVÁCS<sup>1</sup> - László FENYVESI<sup>1</sup> - Péter BURAI<sup>2</sup> - Csaba LÉNÁRT<sup>2</sup>

<sup>1</sup>Hungarian Institute of Agricultural Engineering, Gödöllő

<sup>2</sup>Department of Water- and Environmental Management in University of Debrecen, Centre of Agricultural and Technological Sciences

While there was only such kind of hyperspectral applications in the recent past, which used in projects, nowadays wider and wider practical use of hyperspectral air detection appears in botany, agricultural, environmental protection, military, disaster recovery and other areas, which need environmental data. Majority of technics that used for air hyperspectral detection consists of push-broom or whisk-broom sensors or GPS/INS systems that record navigation data and built in with sensors. Use of direct georeference effects quick data manipulating and easy tractability, at the same time it needs a high precision GPS/INS system, an occurrent failure can endanger the efficiency of the whole detection. As a result of the co-operation of the Hungarian Institute of Agricultural Engineering (HIAE) in Gödöllő and Department of Water- and Environmental Management in University of Debrecen, Centre of Agricultural and Technological Sciences, an AISA DUAL system hyperspectral sensor was procured and installed in 2006. Trial flights were performed in 2007 and the system was tested by different settings. Geometric and radiometric accuracy of the images and the adaptability of different preprocessing methods were analyzed.

In this study, the major technological elements of the system and the major technological specification of the elements of the used system will be demonstrated. Images taken in 2007 and 2008 were tested by C-Migits - III and OxTS RT3003 type GPS/INS systems. Examinations of geometric accuracy of the images, terrain DGPS points were used.

## RESEARCH FOR REDUCTION OF THE ENVIRONMENT DAMAGING EFFECTS OF SPRAYING

Zoltán GULYÁS - László KOCSIS

Hungarian Institute of Agricultural Engineering, Gödöllő

The success of chemical plant protection and its effect on the environment depend on the applied machines and technologies. For example, the type of sprayer system and its adjustment have an effect on pesticide drift. Chemical losses need to be reduced without decreasing the spraying quality. In order to analyse some factors influencing drift, we performed several simulated drift measurements in a wind channel. We investigated the drift of drops coming from TeeJet nozzles (different types), using different settings on our system such as working pressure and laminar air speed. We described the level of drift by calculating the relative coverage on water sensitive paper sheets, which were situated on the floor of our wind channel with a distance of one meter between each.

## STRAIN MEASUREMENT WITH FIBER SENSOR

Károly PETRÓCZKI

Szent István University, Faculty of Mechanical Engineering, Institute of Process Engineering, Gödöllő

The rapid development of electronic and information technology together with telecommunication has a great

influence onto the branches of technology e.g. to the improvement of experimental methods of stress analysis. The article gives an overview about the capabilities and application limits of conventional strain gage. After the discussion the optical "Fiber Bragg Grating" sensor as a strain or temperature sensor is presented. A comparison is given between the "conventional resistance" and the "optical" strain gage.

## CONTINUOUS TILLAGE FORCE MEASUREMENTS – NEW DEVELOPMENTS

Mátyás CSIBA - Miklós NEMÉNYI

University of West Hungary, Faculty of Agricultural and Food Sciences Institute of Biosystems Engineering, Mosonmagyaróvár

The system is based on the electro-hydraulic system (EHS) of a Steyer 9078/A tractor. Load cells are installed in the EHS, which provide electric signals with the ratio of the forces affecting the hydraulic system. The induced voltage from the load cells were fed to the DellAxim x50v PDA (Personal Digital Assistant) using an RS232-ADC module, which converts the analog voltage signals to a digital one. Software developed at the institute – with a simple programming environment Zeus - records and displays the actual force, affecting the hydraulic lever and writes the values to the main memory of the PDA together with the position (GPS) information in \*.txt format. This file format is available for GIS software for later processes. This new innovation makes the earlier development (Neményi et al. 2006) more accurate and provides the system to use in practical field-works. In addition all the accessories are simple and available at relatively low cost rate. Using today's technical development state makes the whole process user friendly. With an eye to the future, the on-line force measurements could provide base information for example continuous on-field bulk density or soil water content estimation.

## ANALYSIS OF CORRELATION BETWEEN THE LOOSENESS DEGREE OF SOIL AND THE TRAVEL SPEED OF THE TILLING COMBINATION

Péter RÁCZ – Zsolt SZÜLE

Szent István University, Institute of Mechanics and Machinery, Gödöllő

The present article deals with one of the partial measurements from the author's research; the purpose of the research is to find a relationship between the looseness  $L_{\chi}$  characterising the working quality of the medium-deep subsoilers and the travel speeds of the tractor-implement tillage combination. In order to determine the soil looseness, the electrical conductivity of soil was measured by a mobile field detector device type Veris 3100 with disc electrodes in field-land conditions. With the help of the method, a function-like relation was proved between the two parameters.

## DESIGN OF AXIAL FLOW FAN ROTOR WITH CONSTANT BLADE CHORD METHOD

Dániel FENYVESI - Ferenc SZLIVKA

Szent István University, Gödöllő

This paper is introduce to constant blade chord method which design method based on non-free vortex (NFV) flow theory. There are reviewed the common used circulation functions and their properties. In addition the paper showed the governing equations of the calculation method and the block diagram of

the iteration. If the blade chord become nearly constant then the easy manufacturing will be possible.

## **ANALYSIS OF THE DRYING TECHNOLOGY OF OIL SEEDS AND CORN KERNELS**

Jenő CSERMELY - Mihály HERDOVICS - József DEÁKVÁRI  
Hungarian Institute of Agricultural Engineering, Gödöllő

Researches were carried out by the financial assistance of OTKA theme (K-60319) in the years of 2006-2007. Examinations were carried out in the laboratory drying system of the MGI but mustard seeds were examined in agricultural plants too. Basis of the laboratory examinations were the harvesting and storage humidity contents of crops and the drying material temperature applied in practice. During the analysis the acreage and maximum drying velocities and in some cases the influence of the material temperature and pollution on the drying process, as well as the duration and the energy demand of the drying process were determined.

## **INCREASING THE SOLUBLE ORGANIC MATTER CONTENT AND BIOGAS PRODUCT OF SEWAGE SLUDGE BY MICROWAVE PRETREATMENT**

Sándor BESZÉDES - Zsuzsanna LÁSZLÓ - Szabolcs KERTÉSZ  
- Gábor SZABÓ - Cecília HODÚR  
Faculty of Engineering, Department of Technical and Process Engineering, Szeged

The food industry has a large waste water product also the development of waste water management technologies increases the mass of produced sewage sludge. Nowadays requires of biomass based energy sources have led to the utilization of organic content of sludge for biogas producing. The controlled biological degradation of organic matters is limited by the complex flock structure - formed by extracellular polymeric substance-, toxically matter and persistent chemical originated from waste water treatment technology. The thermal pretreatments are widely used in the sewage sludge handling to accelerating of dewatering processes or pathogen destruction. The application of microwave technique is very promising because during microwave treatment the cell wall of microorganisms are destroyed, some large molecules are digestion, the cells are opened and the ratio of soluble and biodegradable organic compounds is increased. In our work the effect of microwave pretreatment on the changing of solubility of organic matter, the aerobic biodegradability and biogas production of sewage sludge were investigated. Summarized our experiences, the microwave energy could be an effective technique to sludge handling, because the originally resistant sludge after a microwave pretreatment became more degradable, and the biogas production increased considerably.

**Keywords:** microwave pretreatment, sewage sludge, biodegradability, anaerobic digestion

## **TECHNICAL-ECONOMICAL CHARACTERISTICS OF MACHINE UTILIZATION IN THE DIFFERENT BRANCHES OF CROP FARMING CONSIDERING PLANT SIZE**

László MAGÓ  
Hungarian Institute of Agricultural Engineering, Gödöllő

The present study is a comprehensive survey covering the analysis of the development of the machine stock and the use of

the machines of field crop producing, field vegetable growing and plantation cultivating farms by the application of the means of computer-guided modelling. The characteristics of the machines demanded by the production of different plants are taken into account and special attention is paid to the application of machines with reasonable capacity and technical level in respect of cost by different farm sizes.

Our aim is to stipulate the range of farm size under which the development and operation of an own machine stock is not even with additional machine cost offering worth in the branches surveyed. By this the farm size limit under which the use of the logistically more defenceless lease work is reasonable in order to keep the cost of machine work at an acceptable rate will be defined. This limit varies from branch to branch. This way the fact that the mechanization of the individual branches is highly dependent from the farm size and the diversity of parameters effecting mechanization can be pointed out.

## **CHARACTERISTICS OF MACHINE UTILIZATION OF PLANT PRODUCTION FARMS IN HUNGARY**

Zsolt BARANYAI - István TAKÁCS  
Szent István University, Faculty of Economics and Social Sciences, Gödöllő

The research on primary database deals with the machine supply of private farms and the costs related to machine-use. Prioritized area of examinations is the analysis of co-operation willingness of farmers as regards the utilization of technical resources. The outcomes of the research show significant resource allocation problems, the impact of which can be tracked down in costs of machine use, too. According to our experiences, the co-operation between farmers – which could be an efficient and adequate economic response to the existing problems – is still to be seen. (The research was made with the support of K 63231 OTKA project.)

## **USAGE SIMPLEX METHOD TO DETERMINE REQUIRED NUMBER OF TRACTOR SYSTEMS FOR PLOUGHING**

Lazar SAVIN - Ratko NIKOLIĆ - Timofej FURMAN - Milan TOMIĆ - Mirko SIMIKIĆ  
Faculty of Agriculture, University of Novi Sad, Serbia

Presented in this paper is application of simplex method to determine required number of tractor systems for ploughing. Using simplex method to optimize parameters of ploughing tractor systems on a 2000 ha production unit, 800 m plot length and a 0.8 daN/cm<sup>2</sup> specific soil resistance, it was established that 2.79 units of the 40 kN category tractors was required.

**Key words:** machinery pool, tractors, ploughing, optimization

## **CLOSING FORCE MEASUREMENT ON CRIMPED CLOSURES**

Zsolt MAGYARY-KOSSA<sup>1</sup> - János BENKŐ<sup>2</sup> - Gyula VINCZE<sup>2</sup>  
<sup>1</sup>Sure TORQUE Európa Kft., Budapest  
<sup>2</sup>Szent István University, Gödöllő

The control of the crimped closures sealing is a serious problem for the quality control of the producers using such closures. The sealing of this closure is ensured by the pressure of a seal-ring between the container and the crimped closure. The sealing quality depends on the applied materials, crimped force on the crimping machines and other settings. However the closing force on the sealing can not be controlled directly, just in an indirect way by measuring the torque of the crimped closures.

During the research we have specified the connection between the crimp force, the remaining closing force after the relaxation and the measurable torque, and we have also developed the right instrumentation for the quality control of crimped closures.

## **HUNGARIAN SUSTAINABLE ENERGY FINANCING FACILITY - MARKET ASSESSMENT FOR SUSTAINABLE ENERGY PROJECTS**

Sándor MOLNÁR<sup>1</sup> - Márk MOLNÁR<sup>2</sup>

<sup>1</sup>Szent István University, Department of Informatics, Gödöllő

<sup>2</sup>Szent Istvan University, Faculty of Economics and Business Management, Gödöllő

This study, commissioned by JASPERS, a workgroup of EIB and EBRD, is a quick scan of the sustainable energy market in Hungary. Its aims are to assess whether there is a basis for developing a Sustainable Energy Financing Facility (SEFF) to provide a credit line to domestic Hungarian banks to support investment into sustainable energy projects. The report examines the following aspects of the sustainable energy market:

- Current activities and state of play in the renewable energy and energy efficiency sectors
- Existing sources of finance
- Attitude of financial organizations and current levels of investment
- Current barriers to investment in the sector
- Possible application and suitability of the SEFF to incentivise investment.

The report is based on a brief analysis of publicly available data, data obtained through contacting Hungarian authorities and on interviews with financial organizations and project developers. In total 5 interviews were conducted within the financial sector, 30 ESCO's were contacted and 4 project developers were interviewed. In addition, every attempt was made to engage the responsible Hungarian authorities in our quest for suitable data, much of which was not publicly available. Care has been taken to ensure that the analysis and conclusions are supported by the data collected.

## **THEORY OF WOOD FIRING, SMALL BOILERS**

István SZTACHÓ-PEKÁRY

College of Kecskemét

Efficient and complete combustion is a prerequisite of utilizing wood as an environmentally desirable fuel. In addition to a high rate of energy utilizations, the combustion process should therefore ensure the complete destruction of the wood and avoid the formation of environmentally undesirable compounds. The present of small boilers for solid fuel in Hungary are mostly fired with firewood, wood chips, or wood pellets. Approx. 90% of the new installations are manually fired boilers for fuel-wood with storage tank. The efficiency of many of the old boilers is insufficient and emissions too high. Thus it would be advantageous to replace them by new approved boilers.

## **DEVELOPMENT OF FOREST MACHINE IN RECENT PAST IN HUNGARY**

Béla HORVÁTH

Institute of Forest- and Environmental Techniques, University of West Hungary, Sopron

Forestry mechanization must satisfy the expectations of home forestry management. Most of our special forestry machines are

supported locally (as the product of agricultural machinery producers, but we also import machines). This analysis focuses on the development of home produced forestry machinery. Tasks for today and the near future:

- continuous development of machines that have been produced;
- the development of traditional forestry machines which are new to the current forest management, i.e. (site cleaners, grouting machines, chemical slashers, barkers);
- machine development which promotes the energetic usage of wood (planter and harvester machine line for short rotation energy tree plants, planter and harvester machine line for roundwood growing energy tree plant, harvester machine line for the underwood level of flood plain forests).

## **EXPERIMENTAL PAVEMENTS BUILT ON COHESIVE SOIL**

József PÉTERFALVI - Miklós KOSZTKA - Gergely MARKÓ - Péter PRIMUSZ

University of West-Hungary, Faculty of Forestry, Institute of Geomatics and Civil Engineering

When building forest roads it is important to use local soils for the material of the pavement for environmental and economic reasons. In Hungary the use of cohesive soils is a problem, especially in the areas with higher rainfall. Stabilization with lime is a possible solution. Modern soil-milling machines and binding material feeders make it possible to regularly use this technology. The aim of the experimental road-section is the investigation of the role of lime-stabilisation in the durability of the pavement against the load and volume of traffic. Within the frame of the Regional University Knowledge Centre of Forest and Wood Utilization, the experimental road-section was built in cooperation between the Institute of Geomatics and Civil Engineering and the Zalaerdő Forestry Closed Company. This provides opportunities to analyse and test lime stabilisation technologies in forestry work. This topic is one of the subtasks of the programs of the Forest- and Wood Utilization Regional University Knowledge Centre.

## **A COMPARATIVE STUDY ON THE PERFORMANCE OF THREE DIFFERENT BAND SAW BLADES**

Kinga GERENCSÉR - Erzsébet VARGA

University of West Hungary, Institute of Wood and Paper Industry

This paper discusses a comparative study regarding band saw blades performances. The primary focus of this work was to investigate the performance of newly developed band saw blade compared to traditional blade configurations (swage-set teeth and satellite tipped teeth) concerning quality measures such as size accuracy, and surface quality. Measured manufacturing parameters included: motor performance, blade stress, feeding speed, blade drift, wheel speed, out-of-plane blade deviation, cutting height and thickness. This article contains the detailed description of the research materials and methodologies. Results indicated that it is possible to produce more size accurate and better surface quality lumber by modifying traditional saw blades; moreover a better edge durability can be achieved as well.

**Key words:** Size accuracy, surface quality, edge durability, band saw blade, blade drift, out-of-plane blade deviation.

## UTILIZATION OF TERRESTRIAL HEAT FOR AIR-CONDITIONING OF RELAY STATIONS

László TÓTH - Norbert SCHREMPF - Lajos FOGARASI - Gábor BIHERCZ

Szent István University, Faculty of Mechanical Engineering, Gödöllő

The objective of the project was to develop a simple energy saving system and to adapt it to the relay stations.

Two versions have been preliminary elaborated:

(A) Application of **shallow-well (ground loop) type (reversible) heat pumps** – from the soil layer at 5-to-10-m depth, adjacent to the containers

(B) The other version – a design **without the compressor cycle**

It can be applied in actual practice if a shallow but sizable collector can be installed in the adjacent area to the construction of station of which surface area is suitably large to fulfil the 'heating' in winter or the 'cooling' functions, by the heat absorbed from the soil.

The version (B) is simpler since only a pump and a fan required for the circulation of fluid and air has to be installed in the system; they are controlled by the thermometers mounted in the control cabinet of the station.

## COMPUTER AIDED MODELLING OF WIND FARMS (ENERGY PRODUCTION)

László TÓTH - Norbert SCHREMPF - Annamária KONCZ

Szent István University, Faculty of Mechanical Engineering, Gödöllő

In the planning process of wind farms the volume of expected electrical energy production is the most important technological feature to determine. The stream modifying effects of terrain have an impact on the amount of produced energy in a mountainous area. The calculations are based on expedition wind speed and wind direction measurements recorded at two or three heights. Mainly this is the reason why the modelling process is needed for determining the optimal site and lay-out of an actual wind farm. Nowadays there are two types of model calculations spread. Whilst the WindPro application uses a simplified terrain model, the WAsP (Wind Atlas Analysis and Application Program) application uses a complex stream model. These two modelling processes were compared under special boundary conditions (configuration of terrain, surface friction, wind farm siting).

## TECHNICAL CONDITIONS OF ENERGY-CANE GROWING (Development Trends)

László BENSE - Zsolt SZÜLE - Lajos FOGARASI

Szent István University, Faculty of Mechanical Engineering, Institute of Mechanics and Machinery, Gödöllő

According to the Kyoto Protocol (the international Framework Convention on Climate Change), Europe attempts to decrease the carbon-dioxide emission, and, at the same time, make the member countries independent from the dwindling energy carriers imported mainly from beyond the borders. The EU intends to achieve this objective by increasing the utilization of the renewable energy sources. The members are bound to raise the ratio of the renewable energies by two documents as well; the one (the White Book) concerns the aggregate energy output and the other (directive No. 2001/77/EC) – the electric energy production.

Hungary is capable of increasing the ratio of renewable sources mainly in the fields of the solar, geothermal, wind and biomass-base energies. Since the other renewable capacities are limited in Hungary, the readiest renewable source is the biomass for energetic use.

The energetic utilization of the biomass can be sorted into three large fields: utilization of solid biomass directly for heat production, manufacturing of liquid energy agents (alcohol, vegetable oil as bio-diesel oil) and generation of gas (biogas).

Firing in boilers or other caloric devices (direct heat production) is the cheapest process of the utilization of biomass as energy. Amongst other appropriate materials of biological origin for production of heat (forest and woodworking products and wastes, fuels from woody energy plantations as acacia, poplar and willow, natural cane or reed, different herb-form energy-plantation products and field-land by-products, horticultural wastes etc., the grown energy cane (actually Miscanthus) domesticated by plant-breeding as an appropriate and acceptable energy plant is recommended.

## CAST POLYAMIDE 6 POLYMER COMPOSITES FOR AGRICULTURAL MACHINE APPLICATIONS

Mátyás ANDÓ<sup>1</sup> - Gábor KALÁCSKA<sup>1</sup> - Tibor CZIGÁNY<sup>2</sup>

<sup>1</sup>Szent István University, Institute for Mechanical Engineering Technology, Gödöllő

<sup>2</sup>Budapest University of Technology and Economics, Department of Polymer Engineering, Budapest

In the agricultural applications of structural materials show some typical environment for machine elements. Very often improved abrasion resistance is needed due to high dust content of the surroundings. In slideways and transport systems of crops and grains the antistatic surface is important to avoid static charge and explosion. Further step is when the antistatic behaviour is not enough and fire-retardant or fire-safe polymer is required. Finally we decided to develop some new composite versions of magnesium catalytic cast polyamide 6:

- improved tribology grade having abrasion resistance
- antistatic composite version
- improved fire-resistant version

The magnesium catalytic cast polyamide 6 has a traditional production process in Hungary, so we could launch the research project on the basis of the present chemical plant and laboratory. The new chemical processes for the targeted composites were developed by the industrial partner, Quattroplast Ltd.

## DETERMINING THE PARAMETERS OF MILD HEAT TREATMENT DESTROYING CLOSTRIDIUM PERFRINGENS

Zsófia Sipos-Kozma<sup>1</sup> - Jenő Szigeti<sup>1</sup> - László Varga<sup>1</sup> - Balázs Ásványi<sup>1</sup> - Noémi Ásványi-Molnár<sup>1</sup> - Zsolt Turcsán<sup>2</sup>

<sup>1</sup> University of West Hungary, Institute of Food Science, Faculty of Agricultural and Food Sciences, Mosonmagyaróvár

<sup>2</sup> 46 Fáy Street, 5800 Mezőkovácsháza

The heat tolerance of *Clostridium perfringens*, an endospore-forming anaerobic pathogen, was studied in our experiments. Earlier examinations determined that livers from waterfowl contained up to 5-10 CFU/g *C. perfringens* spores in large-scale industrial operations. By contrast, the counts of *C. perfringens* spores in livers from waterfowl in France were occasionally found to be as low as 1-2 CFU/g. This is most likely due to the differences in slaughtering technology because in Hungary the large-scale conveyor applies cold evisceration, whereas in France warm evisceration is used in small-scale commercial operations, therefore, the risk of contamination is thus reduced. The aim of this study was to determine the minimum heat dose, not exceeding 100°C, needed to produce semi-preserved waterfowl liver. For reasons of competitiveness, it is necessary to use reduced temperatures because French products made

from less contaminated raw materials are heat treated at temperatures ranging from 95°C to 98°C, whereas Hungarian semi-preserved livers are heat at 105-108°C.

### **MODELLING OF HARVESTING BASED ON FIELD TESTS**

Zoltán BÁRTFAI - Péter ILOSVAI  
Szent István University, Institute of Systems Engineering and Management, Gödöllő

Changes in the plant cultivating technologies in Hungary revise the cost-proportion toward the harvesting. Therefore planning the harvesting process from the point of view of performance, losses, quality becomes important very much. Because of the complexity of this problem, the computerized stochastic modelling seems to be applicable quite well. On the present occasion we would like to outline the results of a harvesting model based on an instrumental examination under real field conditions.

**PART II.**

**SELECTED SCIENTIFIC PAPERS**

## EVALUATION OF THE ACCURACY OF THE AISA DUAL HYPERSPECTRAL SYSTEM IN HUNGARY

József DEÁKVÁRI<sup>1</sup> - László KOVÁCS<sup>1</sup> - László FENYVESI<sup>1</sup> - Péter BURAI<sup>2</sup> - Csaba LÉNÁRT<sup>2</sup>

<sup>1</sup>Hungarian Institute of Agricultural Engineering, Gödöllő

<sup>2</sup>Department of Water- and Environmental Management in University of Debrecen, Centre of Agricultural and Technological Sciences

### Hyperspectral sensors

Major elements of hyperspectral sensors are spectrographs, which dissolve the electromagnetic waves that get in through the optical gap to different wavelength bands by prisms and optical grid. Hyperspectral sensor consists of optics, spectrograph and digital camera. The two hyperspectral sensors were built in the same house that is why they are called AISA DUAL system. The cameras detect the visible wavelengths, near infrared and short-wave infrared range.

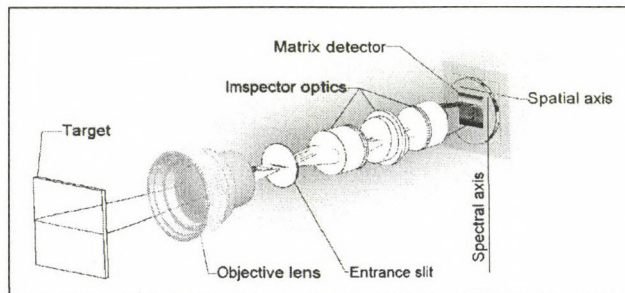

Figure 1 The spectrograph

AISA DUAL hyperspectral imaging system is operated by the University of Debrecen, Centre of Agricultural and Technological Sciences and Hungarian Institute of Agricultural Engineering in Gödöllő jointly, which was built in the Aztec type airplane of AEROMÉDIA Ltd. AEROMÉDIA Ltd. was performed the necessary machine transformations that need to the settings of the instrument and it made possible the first trial flight in October 2006, than test flights from 2007.

### Technical information for the AISA DUAL hyperspectral system:

- Push-broom hyperspectral imaging sensors
- Fiber optic radiation monitor (FODIS) (Figure 2)
- Miniature integrated GPS/INS sensor, which is for the determination of pitch, roll and yaw of the airplane
- Compact PC-based data-collector and mobile archiver unit
- CaliGeo preprocessing software integrated to ENVI, for the completion of spectral and geometric corrections

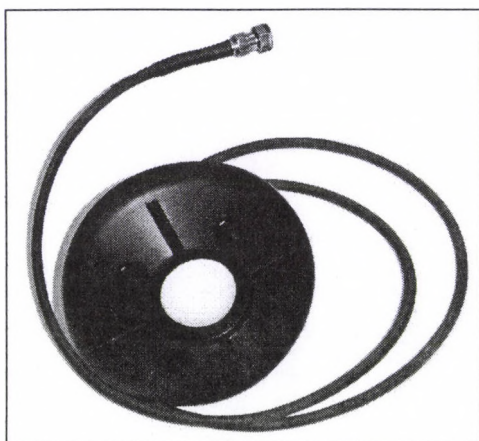

Figure 2 The FODIS sensor

### Hyperspectral image parameters:

Wavelength: 400-2450nm (EAGLE: 400-970nm and HAWK: 970-2450nm)

Spectral sampling: 1.2-10nm

Ground resolution: 0.4- 3m (with aircraft)

A big advantage of the instrument that it can be delivered easily and can be built in the airplane quickly (Figure 3).



Figure 3 PIPER AZTEC airplane and Hyperspectral sensor with OxTS RT3003 GPS/INS unit

Eagle camera is available for imaging in visible and near infrared range (VNIR), while Hawk in short-wave infrared (SWIR). By joint configuration of the two cameras, a DUAL system was put in operation. The whole band width is 400-2450 nm, which can be programmed to 1,25-10 nm channel-widths and maximum 498 channels. The two sensors can be operated separately, so, for-example, we can take advantage of wider bandwidth of higher resolution (1024 pixel) VNIR sensor data.

Table 1 Technical specification of DUAL sensor

	VNIR (EAGLE)				SWIR (HAWK)
<b>Sensors characteristics</b>					
Spectral range	400-970 nm				970-2450 nm
Spectral resolution	2,9 nm				8,5nm
Spectral binning options	none	2x	4x	8x	none
Spectral sampling	1,25 nm	2,5 nm	5 nm	10 nm	6 nm
<b>Fore optics</b>					
#spatial pixels	320		1024		320
FOV	24		24		24
IFOV	0,075 degrees		0,075 degrees		0,075 degrees
Swath with	0,65×altitude		0,65×altitude		0,39×altitude
<b>Electrical characteristics</b>					
Radiometric resolution	12 bits (CCD)				14 bits (MCT)
SNR	350:1 (peak)				800:1 (peak)
Image rate	Up to 100 images/s				

### Plan of measurements

In the phase of planning, contractor have to give the data of the measuring area, wanted spatial and spectral resolution and spectral channel number, from which flight high and minimum flight speed can be calculated. In the next step, flight track should be prepared for the pilot, ensuring the proper overlay between the similar bands (20-50%).

### 4. Test of gps/ins systems

Two type of GPS/INS system was tested for the sensors: the American C-mights-III and the English OxTS RT 3003 type. The RT 3003 is a new generation GPS/INS system, which has two aerials and L1/L2 RTK receiver unit, and its data transfer rate is 100 Hz that means significant accuracy increasing in

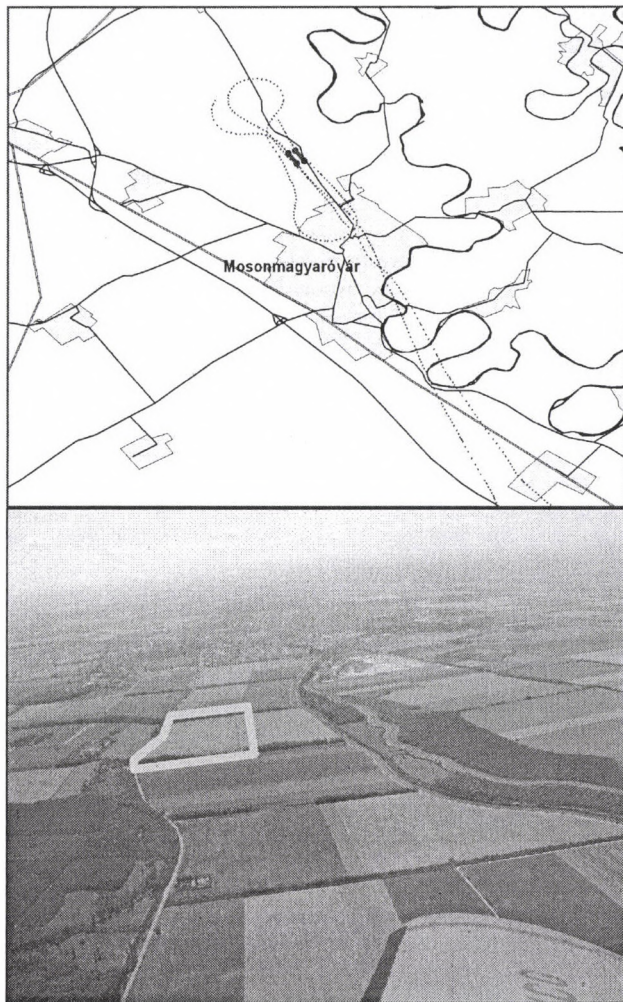

Figure 4 Map and photo of the measuring area

contrast with C-mights III. The RT3003 Inertial and GPS Navigation System is an advanced six-axis inertial navigation system that incorporates an L1/L2 RTK GPS receiver for position and a second GPS Receiver for accurate Heading measurements. The RT3003 delivers better than 0.02m positioning under dynamic conditions using differential corrections and 0.1° Heading using a 2m separation between the GPS antennas.

First steps of data processing (radiometric and geometric correction) were calculated by Caligeo program developed by Specim Ltd. By radiometric correction, the program calculates the data of raw images to physical radiometric values (radiance). Direct georeference was calculated by the data of GPS/INS system, digital terrain model and other external parameters (boresight values, external DGPS data). The major problem by the processing of the first images was the setting of the proper synchronization time, which was manageable automatically by the newer version of Caligeo program, developed by Specim Ltd. Next to the radiance value, FODIS rate can be calculated from the data of irradiance gauge located at the top of the airplane, which represents the rate of the extent of radiance measured by the sensor and irradiation above the airplane.

AISA DUAL hyperspectral air camera was tested in the year 2007-2008 hyperspectral campaign with different settings and sample areas, in Hungary. During the hyperspectral campaign in 2007, 127 hyperspectral images were taken in different areas. Several times, high resolution images (0,5-1,5 m) had to be taken from major coherent areas, where accurate geometry of bands was an important element because of the accurate mosaicing. Controlling of direct geometry, ground-based identifier points (GCP) were used, by which geometric accuracy of the images was estimated. There was a possibility for receiving post-correction data by the OxTS Rt3003 GPS/INS system, where Omnistar Airstar system was used. Default of direct georeference was estimated by ground-based checkpoints in some test images.

Table 2 Sheet of AISA parameters

AISA flight parameters for	HIAE / University of Debrecen	Local ground elevation	80 [feet]	from mean sea level
AISA Eagle Serial Number	SN100026	Local WGS-84 geoid height	46 [m]	
Hawk Serial Number	SN300015	Average ground elevation	70.38407354 [m]	from WGS-84 reference s
AISA Eagle focal length	18,04 mm			
AISA Eagle spatial pixels	46 start	1024 end	978 total	
Hawk spatial pixels	22 start	320 end	299 total	
DUAL spatial pixels	25 start	320 end	296 total	
Change gray areas to calculate FPS, swat width and altitude				
The spatial pixels exclude FODIS area				
The flight altitude is from mean sea level				
Max flight altitude for AISA is specified to 10000 feet				
Use the blue highlighted values in CaliGeo				
		Ground pixel size [m]		[feet]
		1,50		4,92
		Ground Speed [m/s]		[knots]
		60		116,63064
AISA Eagle	SN100026_210606_XB.cal			
Binning	Spectral sampling ~	Spatial pixels	MAX FPS	FPS
8x2	10 nm	489	129	40,00
4x2	5 nm	489	89	40,00
2x1	2.5 nm	978	54	40,00
2x2	2.5 nm	489	54	40,00
1x1	1.2 nm	978	30	40,00
1x2	1.2 nm	489	30	40,00
AISA Hawk	SN300015_200906_B.cal			
Binning	Spectral sampling ~	Spatial pixels	MAX FPS	FPS
1x1	6 nm	299	103	40,00
DUAL	DUAL_SN100026_300015.cal			
	DUAL_SN100026_300015.cal			
Binning	Spectral sampling ~	Spatial pixels	MAX FPS	FPS
Dual mode 4x2	Eagle 5 nm, Hawk 6nm	296	89	40,00
Dual mode 2x2	Eagle 2.5 nm, Hawk 6nm	296	54	40,00

**Table 3**

GPS/IMU system	Number of images	Number of GCP points	max. RMSE (m)	min. RMSE (m)	Average RMSE (m)
C-migits-III	3	28	14,01	4,81	6,10
OxTS RT3003	3	24	4,44	0,31	3,03
OxTS RT3003 with Omnistar	3	24	1,52	0,15	1,21

Major default by the usage of C-migits GPS/IMU system was that calculated accuracy changed continuously by the continuous changing of GPS signs, so error deviation was high in some cases within a band, which could be mended hard also by geometric correction. Hyperspectral dual sensor is fixed without gyroscope to the airplane, so deviation, origins from the movement of the airplane, is resettled by the geometric correction. Analyzing navigation data we can establish that in case of those images, which were taken under average circumstances, angle deviation of the airplane stays within 10 degrees, in more cases within the 0-6 degrees range. However, in particular weather situation, bigger differences was measured that exceeded seldom 15%.

**Table 4**

Angle deviation (degree)	Roll (%)		Pitch (%)		Heading (%)	
		sum		sum		sum
0-2	31,20	31,20	31,57	31,57	35,82	35,82
2-4	39,62	70,82	54,05	85,62	18,63	54,45
4-6	17,15	87,97	9,3	94,92	28,31	82,76
6-8	8,11	96,08	1,9	96,82	15,66	98,42
8-10	3,92	100	3,18	100	1,58	100

**Data processing after the measurement**

Preprocessing of recorded data by Caligeo program, which is a module of ENVI software and developed by SPECIM Ltd. Necessary for the processing:

- raw data,
- calibration data of sensors,
- navigation data of GPS/INS unit,
- parameters of the settings,
- digital terrain model, which can be used optional.

Caligeo calculates radiometric and geometric correction by the above data.

Before mosaicing the images, bands have to be refined by parametric correction, if necessary.

**Results and discussion**

By high resolution (0,4-1,5m) hyperspectral images taken with push-broom type sensor proper geometric accuracy can only be generated by precision GPS/IPS system, usage of parametric correction is not adaptable because of the lack of fit points and the changing of the spread direction of error. The OxTS RT 3003 system, operating by two aerials seemed to be reliable of the GPS/INS system we used, also without DGPS correction. Images taken by C-migits III type instrument without DGPS correction, usage of parametric postcorrection is necessary for the increasing of accuracy.

*The following establishments can be given by the aim of increasing radiometric and geometric accuracy of images taken by hyperspectral camera:*

- Direct geometric correction without GPS's data requires an accurate GPS/INS system like OxTS – RT 3000 family or continuous DGPS service during acquisition
- CaliGeo software is proper for making radiometric and direct geometric correction without external GPS's data
- Usage of accurate DEM is necessary for the increasing of geometric accuracy
- For the calculation of FODIS ratio, GPS/ INS navigation data are required in this case to drop out the unsuitable FODIS values

In the future, development of a product specific atmospheric correction model is necessary.

We plan the following agricultural and environmental protection applications in the future:

- landuse detection, control, following of changes,
- landcover detection,
- precision agricultural applications,
- biomass measurement,
- detection of invasive plant species (eg. Ambrose),
- determination of phytoplankton content of surface water, detection of water pollution,
- state evaluation of plant vegetations,
- soil surface soil state evaluation,
- monitoring of the moisture content and minerals of soils,
- detection of pollutions, follow up of the rate of spreading.

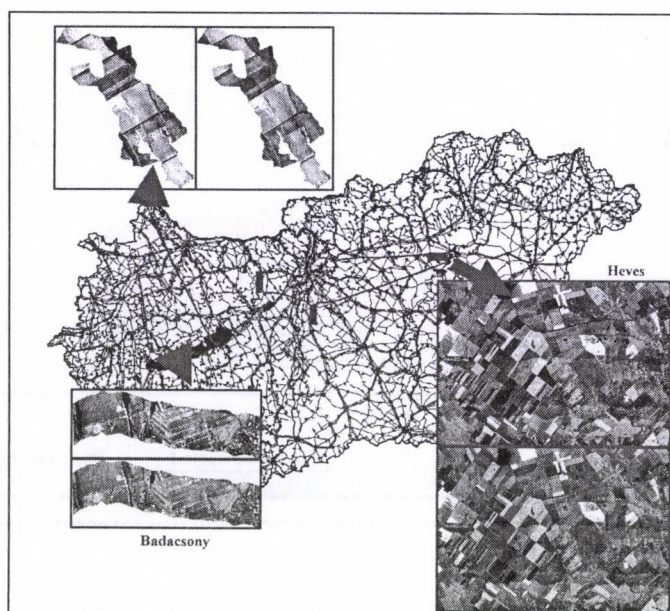

**Figure 5 Images after data processing**

# RESEARCH FOR REDUCTION OF THE ENVIRONMENT DAMAGING EFFECTS OF SPRAYING

Zoltán GULYÁS - László KOCSIS

Hungarian Institute of Agricultural Engineering, Gödöllő

## Introduction

Agricultural cultures can be efficiently protected against yield-decreasing and debasement caused by pests, diseases, and furrow weed only if the expertly chosen insecticides will be sprayed on-time, in appropriate quantity and evenly on the entire target field. If the expected result lags behind, the farmers often suspect the applied insecticide of being inefficient, indeed it is obvious, too, that the insecticide could not be sprayed adequately onto the target field. One essential condition and requirement for the sake of the successful and effective pest-control is the utilization of both the appropriate machine and technology. The effect of the chemical control on the environment depends significantly on the used machines and the technology, respectively. The machine system and its build-up as well as the technology applied during the pest-control activities influence drastically the waste-level of the chemicals, moreover its treat and pollution onto the environment.

## Materials and Methods

In the wind tunnel the modelled drift investigations were carried out with 4.0 and 6.0 m/s laminar wind speed and operational pressure were set to 3.0 and 4.0 bar. During the investigations from the different types of nozzles (TP, DG, AIXR, AI) the most used 110 04 types were investigated. In the wind tunnel ws papers were positioned 1 pcs directly under the spraying nozzle which had a 500mm fixing height and another 7 pcs ws papers were positioned 1 m from each other; the size of the paper was 52x76mm. After the test the papers were collected and scanned. The relative grade of covering was analyzed by the National Instruments LabVIEW Vision program.

## Results and evaluation of results

From the results of the analysed ws papers were depicted the following diagrams.

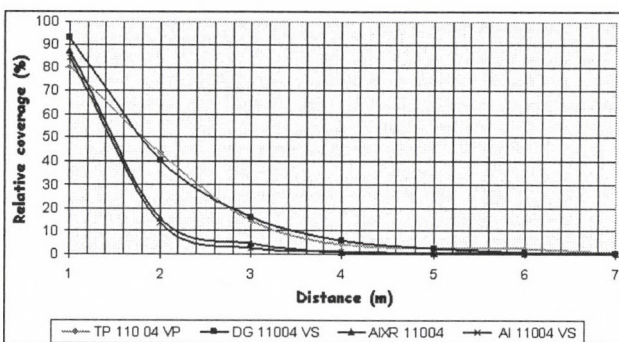

Figure 1 The drift of the TeeJet nozzles (p=3.0 bar, v=4.0 m/s)

In the fig. 1. the results of the test can be seen when the op. pressure was 3.0 bar and the wind speed was 4.0 m/s. The drift of the classical type of nozzle is significant on the hole range (1-6 m: 80,1-2,6 %) and the relative grade of covering also significant ( $\geq 1$  %) on the measuring border (7 m). The results of the drift guard type DG 11004 VS nozzles also high till 6 m (93,0-1,0 %) but on the 8<sup>th</sup> paper just 0,4 %. The passive injector types AIXR 11004, and AI 11004 VS nozzles up to 4 m more than 1% (87,2-1,0 %, and 84,3-1,2 %), but from 5<sup>th</sup> m the drift is neglectable.

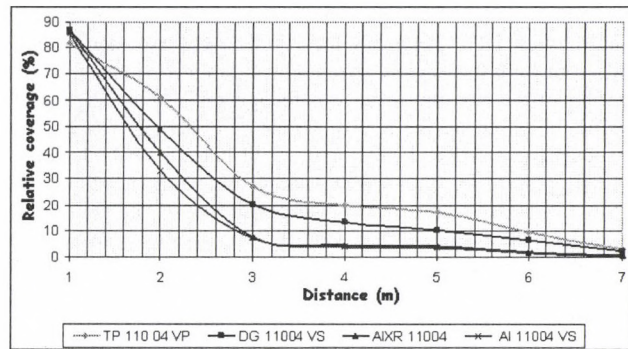

Figure 2 The drift of the TeeJet nozzles (p=3.0 bar, v=6.0 m/s)

In the fig. 2. the results of the test with op. pressure 3.0 bar and the wind speed was 6.0 m/s observable. The drift of the classical type of nozzle and the drift guard type DG 11004 VS nozzles also significant on the hole range (81,6-3,0 %, and 86,9-2,2 %). The passive injector types AIXR 11004, and AI 11004 VS nozzles up to 6 m more than 1% (86,6-2,1 %, illetve 85,3-1,3 %), but from 7<sup>th</sup> m the drift is still neglectable.

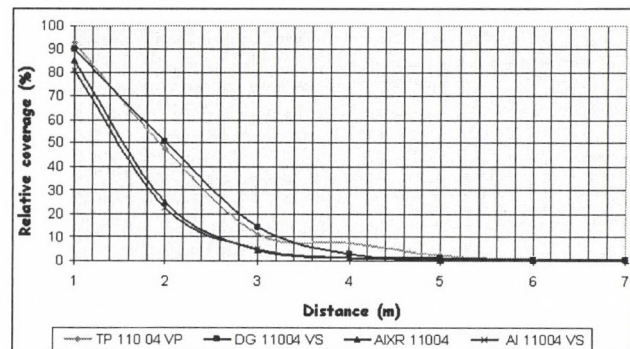

Figure 3 The drift of the TeeJet nozzles (p=4.0 bar, v=4.0 m/s)

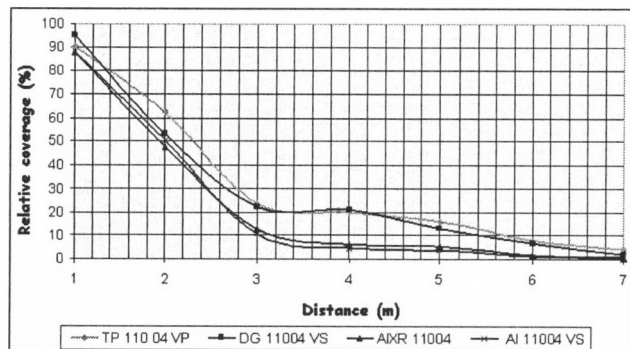

Figure 4 The drift of the TeeJet nozzles (p=4.0 bar, v=6.0 m/s)

In the fig. 3 and 4. the results of the test with op. pressure 4.0 bar and the wind speed were 4.0 and 6.0 m/s can be seen. The drift of the classical type of nozzle TP 110 04 VP and the drift guard type DG 11004 VS nozzles also significant up to the 5<sup>th</sup> m (92.2-2.7 %, and 90.0-1.3 %) from 6<sup>th</sup> m the drift were reduced (0.8-0.4 %, and 0.0-0.3 %) for 4.0 m/s wind speed but for 6.0 m/s wind speed the drift is very high (90,1-4,0 %, and 95,0-2,0 %). The passive injector types AIXR 11004, and AI 11004 VS nozzles up to 4 m more than 1% (85,4-1,1 %, and 81,1-1,2 %) for 4.0 m/s wind speed and for 6.0 m/s wind speed up to 6 m more than 1% (87,6-1,8 %, and 88,3-1,1 %), from 5<sup>th</sup> and 7<sup>th</sup> m the drift were neglectable.

## Discussion and Conclusions

Based on the results of the simulations verifiable that in the case of the classical TP 110 04 VP types under different conditions

the drift is significant in the whole range. In the case of the drift guard types DG 11004 VS the results were not significantly different for 6.0 m/s wind speed. For 4.0 m/s wind speed on the border of the measurements was recognizable some slight drift reduction based on the relative grade of covering. The passive injector types AIXR 11004, and AI 11004 VS on both operational pressure for both 4,0 m/s and 6 m/s wind speed the drift reductions were significant compare with the TP and DG types. Based on the results of the wind tunnel investigations statable that the classical edge type nozzles are not recommendable for bigger than 3 m/s wind speed because the driftage and the maximal drifted distance also widely increase. Hereby the possibility of the environmental damage also increases. The drift guard nozzles against the driftage are able to reduce the driftage also just till 4 m/s so these types are also not recommendable for over 4 m/s wind speed. The passive injector nozzles are able to reduce the driftage up to 6 m/s wind speed (under proper operation conditions: working speed, operational pressure, distribution).

#### References

[1] Gulyás Z. (2004): Hogyan csökkentjük a permetlé elsodródását? *Agrárágazat*, V. Évfolyam 1. szám) p. 32-37.

[2] G. Dimitrievits - Z. Gulyás - L. Kovács (2004): Results of environmentally friendly spray application techniques in Hungary. International Conference „Environmentally Friendly Spray Application Techniques”. Book of Abstracts, Warsaw, Poland, 2004. október 4-6. p. 149.

[3] Z. Gulyás - Gy. Dimitrievits (2004): Versuche mit angewandten verlustmindernden technischen Lösungen beim Spritzen. Conference: Agricultural Engineering - 62. VDI-MEG Tagung Landtechnik. Konferencia-Kiadvány (ISSN 0083-5560; ISBN 3-18-091855-1 – Precision Farming), Dresden, 2004. október 7-8. p. 455-462. (VDI-Berichte Nr. 1855, 2004).

[4] Dimitrievits Gy. - Gulyás Z. - Kovács L. (2007): Környezetkímélő, vegyszertakarékos permetezési eljárások. XXXI. MTA-AMB Kutatási és Fejlesztési Tanácskozás az agrárgazdaság gépesítéséről. Konferencia-Kiadvány 2. kötet (ISBN: 978-963-611-443-5; ISBN: 978-963-611-445-9), Szent István Egyetem Gépészmérnöki Kar, Gödöllő, 2007. január 23. p. 23-26.

[5] Dimitrievits Gy. - Gulyás Z. - Kovács L. (2007): Szántóföldi permetezés hatékonyan. *Magyar Mezőgazdaság*, 62. évfolyam (12. szám) p. 22-23.

# STRAIN MEASUREMENT WITH FIBER SENSOR

Károly PETRÓCZKI

Szent István University, Faculty of Mechanical Engineering,  
Institute of Process Engineering, Gödöllő

## Objective

The resistance type strain gage (SG) was patented by E.E. Simmons and A.C. Ruge (USA) independently of each other in 1938, and the first SG manufacturer Baldwin-Southwark Corp. (USA) was established in 1941 [1].

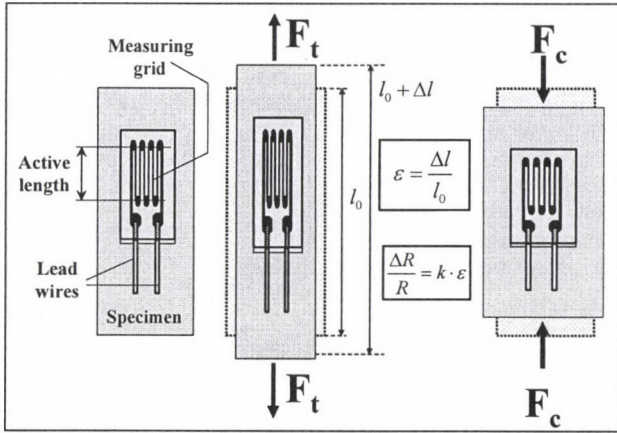

Figure 1 The principle of resistance type strain gage

The resistance type strain gage consists of so-called "meander form" (wave line) sensing conductor (grid) on the surface of a plastic foil (carrier) and lead wires or solder terminals to connect the sensor to the measuring electronics. This sensor is bonded on the surface of the specimen. The mechanical load deforms the specimen and together with it the strain gage, too. The resistance of the sensor changes according to the relative change of length called strain ( $\epsilon$ ) of the grid. The change of the sensor's resistance is proportional with the strain. The principle is presented on the Fig.1. The resistance type strain sensor (strain gage) is connected in a proper 1/4, 2/4 or 4/4 bridge configuration to the measuring amplifier. The present strain gage technology together with electronics, the accuracy, the reliability are at the high level. The prices are reasonable, the application range is wide and the application technology has worked up well.

What should be the problem with strain gage technology? What is the motivation to develop a new technology for strain measurement? The answer to the first question is simple: practically no problems with strain gages. We must observe a few technical achievements in our period to answer to the second question.

## The principle of the new strain sensor

Last few decades composites have appeared in agricultural tanks e.g. on field sprayer, next seed containers of seeding machines, in other fields: wind blade of wind-power plants and the wings of Airbus A340-600. Last 15 year fiber optics in telecommunication and in computer networks has emerged into our everyday-life. The principle of the transmission fibre is the following. The transmitter generated light enters into the transmission fibre. The inner part of the transmission fibre has a  $n_1$  refraction index, which is higher than the outer part  $n_2$ . So the light has a total reflection, can not leave the fibre only at the receiver, see Fig. 2. The wave modulus depends on the diameter of the core. The core diameter of advanced fibre is cca. 10  $\mu\text{m}$  now, so only a single or limited number of wave modes can be formed. This is the so called single mode fibre. Today with up-

to-date materials approx. 50 km distance can be transmitted without any amplification.

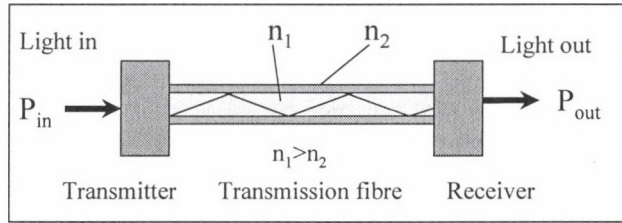

Figure 2 The principle of the transmission fibre

Let's assume, that  $n_1$  refraction index core has a short length inhomogeneous part with  $n_3$  refraction index! At the  $n_1$ - $n_3$  border (and at the  $n_3$ - $n_1$  border, too) a partial reflexion occurs, the a part ( $P_{refl}$ ) of the  $P_{in}$  input light power is reflected at the border and the reflected  $P_{refl}$  light power travels back. The remain  $P_{out} = P_{in} - P_{refl}$  travels further, see Fig.3.

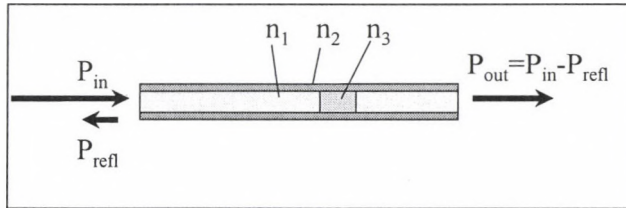

Figure 3 The partial reflexion at inhomogeneous refraction index of the core

Put  $n_3$  zones onto the core with  $\Lambda$  periodicity! The same effect occurs at the 1., 2., 3., ... border, at the input part of the transmission line wave interference generated from the reflected lights (Fig.4.). Let's analyse only the special case, if the reflected waves amplify each other, the power of the reflected components can be added.

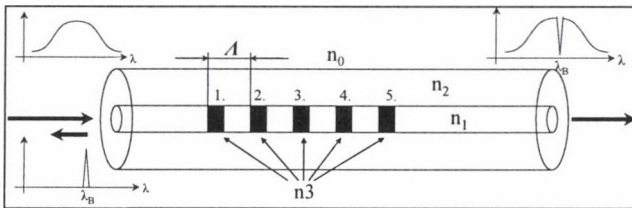

Figure 4 Partial reflexion at periodic 1., 2., 3., ... inhomogeneous refraction index border

The waves can amplify each other, if they interfere with the same phase, so the reflected waves have to travel the multiplication of wave length (Equ.1), called Bragg-wave length ( $\lambda_B$ ).

$$\frac{\lambda_B}{n} = 2 \cdot \Lambda \quad (\text{Equ.1})$$

Where:

$\lambda_B$ : Bragg-wave-length

$n$ : the average of  $n_2$  and  $n_3$  refraction index

$\Lambda$ : grid period

Typical values:

$n=1,46$

$\lambda_B=1550 \text{ nm}$

$\Lambda=530 \text{ nm}$

Let's suppose the length of the sensor  $l=6 \text{ mm}$

The number of grids:

$$N = \frac{l}{\Lambda} = \frac{6\text{mm}}{0,53 \cdot 10^{-3}\text{mm}} = 11300$$

Every grid can reflect the very small amplitude  $\lambda_B$  Bragg-wave, but in case of 11300 reflection the value of the summed reflected amplitude is considerable. With simplification of the effect, we can say, that the  $\lambda_B$  Bragg-wave length depends on the  $\Lambda$  periodicity of the grid:  $\lambda_B = \lambda_B(\Lambda)$ . Let's suppose, that the length of the fibre sensor changes, together with it the periodicity of the fibre grating varies and the  $\lambda_B$  Bragg-wave changes, too. This change of the lengths comes from the change of the temperature or the change of the mechanical load. So temperature ( $\Delta T$ ) or strain ( $\Delta \epsilon$ ) change can be measured with this fibre Bragg grating sensor.

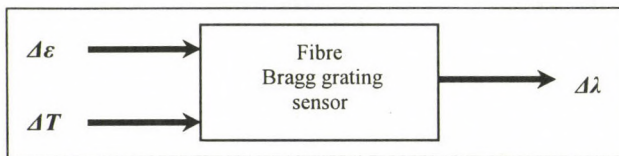

Figure 5 The Bragg-wave length is function of the strain and the temperature

Typical values are:

$$\begin{aligned} \Delta \epsilon = 1 \mu\text{m/m} &\rightarrow \Delta \lambda_B = 1 \text{ pm} \\ \Delta T = 1 \text{ K} &\rightarrow \Delta \lambda_B = 10 \text{ pm} \end{aligned}$$

This sensor is a so called "passive" sensor, an external laser light power and an electric output Bragg wave sensor is necessary. This instrument is the interrogator. Two techniques of determination of the Bragg wave is presented now. The basic parts are the broadband light source, a circulator (or directional coupler), the transmission fibre, the FGB sensor and the optical spectrum analyzer, see Fig. 6. The optical spectrum analyzer can be an "edge filter interrogator", similar as a frequency/wave length discriminator or a CCD based interrogator.

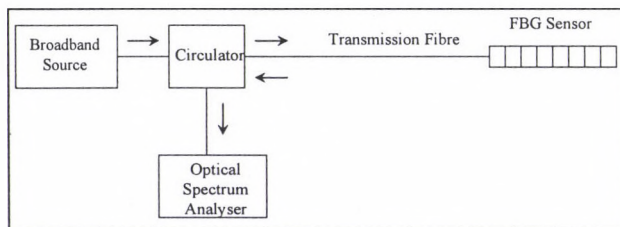

Figure 6 FBG measurement with broadband light source and optical spectrum analyzer

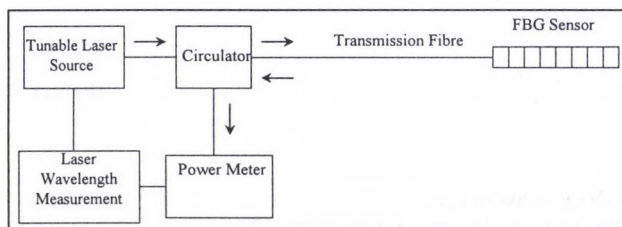

Figure 7 FGB measurement with tunable laser and reflected power detection

Fig. 7. shows the second measuring method. The tunable laser source sweeps over a spectral range including the FBG spectral peak. The laser wavelength measurement module records the Bragg peaks detected by the power meter. This second mode of the measuring technique has a great advantage: several measuring channel can be measured on the same transmission fibre [2, 3].

## Conclusions

Advantages of the fibre Bragg-grating sensors (FBGS):

- Small sized and lightweight
- No influence of electromagnetic fields
- No electrical power necessary can be put into high voltage or potentially explosive area
- Long distance between the sensor and the measurement system (up to 50 km)
- More then one grid within only a single fibre (up to 20 sensors)
- Long term stability is very high
- Good corrosion resistance
- Simple to integrate into composites.

Disadvantages of FBGS:

- Resolution cca. 5  $\mu\text{m/m}$ , worse than metal foil strain gage (SG)
- High temperature dependence:  $\Delta\lambda/\lambda_0$  caused by 1 °C is equivalent to  $\Delta\lambda/\lambda_0$  caused by 10  $\mu\text{m/m}$  mechanical strain, self temperature compensation is not possible
- Gage factor is only  $k \approx 0,78$  and can be different from fibre to fibre
- Small size of strain gage cannot be reached with FBGS
- Shows high sensitivity to lateral forces or pressure
- Stiffness is higher than that of a metal foil SG
- Min. bending radius of the fibre should be  $>10 \text{ mm}$
- Interrogator is still expensive (cca. 20.000 €)
- Distance between sensing fibre core from the specimen surface is valuable, so calibration error occurs on the curved surface.

After analysing the advantages and disadvantages of the FBGS the recommended areas of the applications are:

- High voltage surroundings
- Hazardous (potentially explosive area) locations
- Direct embedding into structures e.g. composites
- Long distance between sensors and measuring system

## References

- [1] K. Hoffmann: An Introduction to Measurements using Strain Gages. Hottinger Baldwin Messtechnik, Darmstadt, 1989.
- [2] Manfred Kreuzer: Strain Measurement with Fiber Bragg Grating Sensors. HBM offprint. [http://www.hbm.com/fileadmin/mediapool/techarticles/2007/FBGS\\_StrainMeasurement\\_en.pdf](http://www.hbm.com/fileadmin/mediapool/techarticles/2007/FBGS_StrainMeasurement_en.pdf)
- [3] W. Gornall, T. Amarel: Application and Techniques for Fiber Bragg Grating Sensor Measurements. Fiber Bragg Grating Sensors. White Paper #1. [www.exfo.com](http://www.exfo.com) p.1-5.

## CONTINUOUS TILLAGE FORCE MEASUREMENTS – NEW DEVELOPMENTS

Mátyás CSIBA - Miklós NEMÉNYI

University of West Hungary, Faculty of Agricultural and Food Sciences Institute of Biosystems Engineering, Mosonmagyaróvár

### Objective

The all-time goal of agricultural production is to fulfill the food request of population on the Earth. The rapidly decreasing land and the growing population make it more difficult (Milics, 2008). The aim of sustainable development is to preserve the land, water, plant and animal genetic variability, which is technically implementing, economically viable and socially acceptable. Precision agriculture is a capable way to execute it. Measuring the yield, grain moisture content on-line, or the site-specific nutrient and chemical assignment are widely used precision techniques (Milics, 2007). As the soil is one of the main renewable energy resources (Várallyay, 2007) the precision tillage starts to play a much bigger role than ever. Sustainability from soil tillage viewpoint can evolve towards great efficiency of resource use, and can develop and maintain a harmony between crop production technologies and soil environment (Birkás et al. 2007). Also the rapidly developing computer science produces better and better hardware and software for agricultural use. Critical functionality of modern agricultural equipment could not be achieved without electronic system. The future looks promising for mobile agricultural electronics (Stone et al. 2008).

One of the most known physical soil parameters is soil strength. Several authors (Desbiolles et al. 1999, Szöllösi, 2003, Gorucu et al. 2006) discuss the measuring methods to determine cone index using a penetrometer, because this process is the most common used technique to determinate soil strength or to predict the tillage force (Desbiolles et al. 1997, Godwin et al. 1977). According to Neményi et al. (2006) the biggest problem of a vertical penetrometer is, that the recorded values are available only from the measured point, and areas among these points are described with calculated data. Al-Jahil et al. (2001), Sirjacobs et al. (2002) Kheiralla et al. (2003) and Bentaher et al. (2008) are presenting results obtained by a three-point hitch dynamometer, which is capable to measure the horizontal and vertical forces affecting the tillage tool. Except of Sirjacobs et al. (2002) no position (GPS) recording is mentioned, therefore the recorded data can not be used to determine the spatial heterogeneity. Besides this an additional force sensor is needed, which make the system more complicated. Accurate tillage depth measurement is also an essential parameter for site-specific draught calculations. Mouazen et al. (2005) highlights on the importance of depth control system. It is a useful parameter for controlling the depth of the tillage tool during online measurement of soil compaction indicated a dry bulk density. However, Mouazen et al. (2006) concluded that there is no clear correlation between soil properties and measured draught, and therefore the field measurement is not the best procedure to correlate draught with the other influencing parameters (depth, water content, bulk density) and theoretical modeling is still an alternative option, Neményi et al. (2006) founded a significant impact between high tillage force and yield. Also Whalley et al. (2008) and Trušić et al. (2008) have found a clear correlation between the yield and the soil strength. After the listing of the scientific references it is still an outstanding question, how to solve the on-line soil draft measurement for practical use, because no acceptable solution exists, however soil draft is one of the key parameters for site specific soil tillage and it could provide base information for example continuous on-field bulk density or soil water content estimation. The aim of this study was to evaluate the soil strength continuously in a modern, cost effective way, what can be used easily in everyday practice.

### Methods and materials

The system is based on the electro-hydraulic system (EHS) of the Steyer 9078/A tractor. Load cells are installed in the EHS, which provide electric signals with the ratio of the force affecting the hydraulic system. The hydraulic system was loaded with certain forces. For reference force values we used a max. 10 kN chargeable load cell, connected to an universal measuring unit (Almemo). Figure 1. represents the correlation between the voltage change and the simulated force.

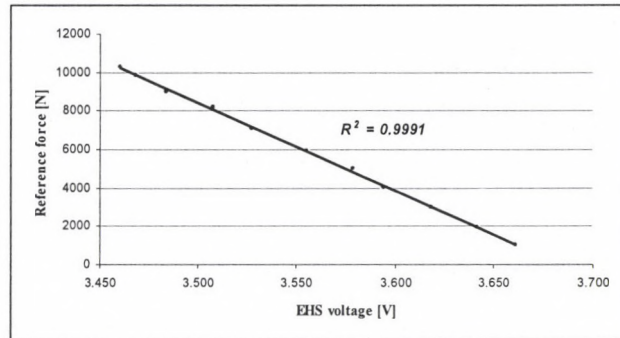

Figure 1 The correlation between the voltage change and the simulated force

The induced voltage from the load cells were fed to the DellAxim x50v PDA (Figure 2.e) (Personal Digital Assistant) using an RS232-ADC module (Figure 2.c), which converts the analog voltage signals to a digital one. Software developed at the institute – with a simple programming environment Zeus - records and displays the actual force, affecting the hydraulic lever and writes to the main memory of the PDA together with the position (GPS) information – recorded by CSI Wireless DGPS Max (Figure 2.d) - in \*.txt format. This file format is easy to use (don't need a special software) for post processing the raw data and it's compatible with GIS applications for later processes, so the results can be displayed spatially. The working speed and depth are the most influencing parameters of the tillage force measuring; therefore the working speed was obtained from a GPRMC - recommended minimum specific GPS/Transit data - line of the NMEA sentence.

```
$GPRMC,101337.00,A,4753.48819,N,01716.29480,E,0.17,335.72,131207,,A*56
```

The highlighted number is a speed in knots. The conversion is: 1 knot = 0.5144 m sec<sup>-1</sup>. To record the actual working depth we used an ultrasonic sensor (Figure 2.a), connected to the tillage tool. Its accuracy was tested even on stubby filed running on different speeds. The correlation between the reference depth (measured with a tape measure) stayed over R<sup>2</sup> = 0.9877. Also a 3 sec alleviation was applied (with a condenser built in to the controlling panel - Figure 2.b) in order to moderate or even eliminate the fluctuation which may be caused by the not perfectly constant working depth and the direction of load. For the post process of the measured data we used Microsoft Excel 2003 (Microsoft Corp.) and Arc View 9.1 to demonstrate the spatial distribution.

### Result and discussion

Figure 1. represents the correlation between the draft force and the EHS voltage change. The high R<sup>2</sup> values shows that there is a strong connection between the listed parameters, so we can declare that the draft force can be determinate continuously with the voltage change of electro-hydraulic system of a tractor. Using the PDA with an in-house software we can easily display the actual draft force with the coordinates and we are also able



# ANALYSIS OF CORRELATION BETWEEN THE LOOSENESS DEGREE OF SOIL AND THE TRAVEL SPEED OF THE TILLING COMBINATION

Péter RÁCZ – Zsolt SZÜLE

Szent István University, Institute of Mechanics and Machinery, Gödöllő

## Scope of the research

The function of the medium-deep subsoilers is to deepen the cultivated layer of the soil. With the help of these implements, the harmful soil compaction due to the regular use of heavy machines with high wheel contact pressure can be successfully prevented in the way that, up to the depth of 30 to 50 cm, only a medium-deep loosening is carried out. The mounted or drawn implements are usually made with  $\Delta$ -type frame with a height of 800 to 900 mm. The working quality of the medium-deep subsoilers applied in the soil tillage technologies without turning is greatly influenced by the design of the actual web-plate as well. The cultivating tools (points) are mounted onto this plate; there is V-, chisel- and wing-design used.

Besides the above mentioned designs of the loosening tool and the web-plate, the working depth of loosening and the travel speed of the tillage combination significantly influence the degree of the looseness of the soil. In this article, the author presents the way of determination of an accurate relationship of the looseness degree as a function of the travel speed.

## Test conditions

Date of the measurement: 12.08.2007

Weather: dry and sunny

Air temperature: 32 °C

Test field: plane cohesive cereal stubble

Moisture content of the soil: 13.2 %

The *Arany* cohesiveness number of the soil: 56

Average penetration resistance of the soil at the cultivated depth: 4.1 MPa

Physical soil type: clayey loam

## Methods and materials

The measurements were carried out in the field of a family farm in Marcali (Hungary). Five parcel patches were staked out on the chosen arable land. Before starting the experiment the setting of both the subsoiler and the detector device *Veris* were carried out in the so-called adjustment field [1].

On the experimental parcel patches, the soil loosening was performed by a five-blade subsoiler equipped with parabolic web-plates. On the middle and the two side consol plates, wing-tools and, on the other two ones, loosening tools of V-shape were mounted. The working width of the implement: 2.2 m, the set working depth: 30 cm, the pitch of the consol plates: 50 cm, the loosening wedge: 6-cm and the wing-tool: 15-cm wide and the penetration angle into the soil: 25°.

The subsoiler was drawn by a 143-kW tractor type New Holland TM 190 with an auxiliary front-wheel drive.

The loosening degree was determined with the help of the process already tested in a loamy soil and based on the measurement of the electrical conductivity of the soil. In the first part of the experiment, the applicability of the elaborated process for the actual soil was examined. Accordingly, the ratio by the formula (1) was calculated from the coherent electrical conductivity data collected before and after the loosening.

$$L_{\chi} = \frac{\chi_{1bef} - \chi_{1aft}}{\chi_{1aft}} \cdot 100 [\%] \quad (1)$$

where

–  $\chi_{1bef}$ : conductivity measured before loosening (mS/m)

–  $\chi_{1aft}$ : conductivity measured after loosening (mS/m)

The collected data base was ‘trimmed up’ during which data groups were formed within the limits of  $\pm 10\%$  deviations. The 10-% value was chosen because, according to the relatively high homogeneity of the soil, the determining of the looseness of the soil with this accuracy can be accepted also in the practice. Then the data of the group with the values in the largest number were averaged. This average of the data characterising the best the measuring parcel was compared with the conventional looseness values based on the analysis of soil cross-sections made by digging. During the evaluation it was proved that the looseness data determined by the conventional method and the novel process used in the author’s research give the same value to a close approximation.

For measuring the electrical conductivity of the soil, the conductivity measuring device type *Veris 3100* was used, and operated by a tractor type *MTZ-82* in the author’s research [4].



Figure 1 Measurement of soil electrical conductivity after medium-deep loosening [3]

The tests were carried out along a 150-m measuring section. For the relationship analysis, the selected travel speeds of the tilling combination were 2.5, 4.3, 6.2, 7, 8.7 km/h. Accordingly, five  $L_{\chi}$  values belong to the five travel speeds.

At first the electrical conductivities of soil were measured along the five measuring uncultivated sections. Then all the five measuring sections was loosened at a medium depth (about 30 cm) by the above shown subsoiler (Figure 2).



Figure 2 Tractor-subsoiler combination for the medium-deep loosening

Finally, in the loosened soil of the measuring sections, the conductivity measurement was repeated (Figure 1), taking care that the *Veris* measuring device should be drawn along the possibly same track as that determined for the conductivity measurement in the uncultivated soil. During the measurement, the tractor drew the *Veris* at the speed of 2 m/s over all the measuring section. The collected data can be easily loaded down from the storage unit of the measurement device placed

on the tractor in such a format which is compatible with spreadsheet programs.

## Results

For eliminating the units, ratios were formed from the measured properties (Figure 3). During fitting a function on these ratios the following relationship proved itself the best:

$$L_{\chi'} = L_{\chi'_{\max}} \left(1 - e^{-rv_{trav}^2}\right) \quad (2)$$

where  $R^2 = 0.9843$  and  $b = 3.64$ .

The relationship (2) is similar to Kacigin's function of comminution degree against travel speed determined on cultivators [3].

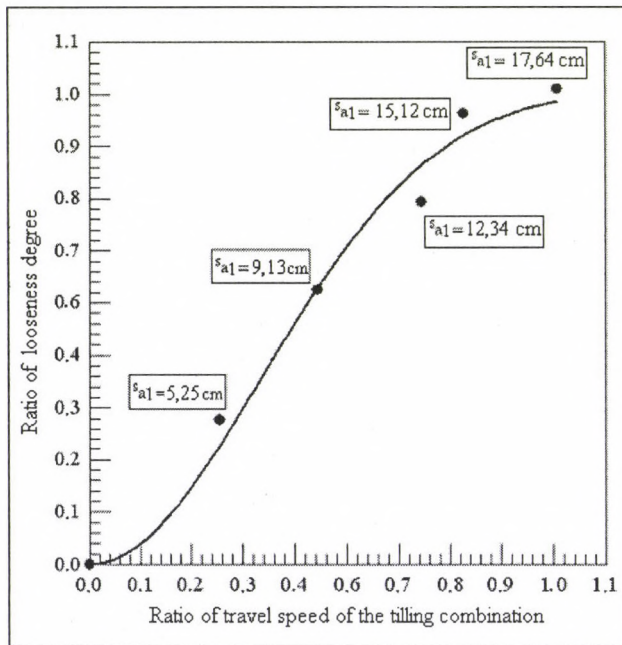

Figure 3 Tractor-subsoiler combination for the medium-deep loosening

The formula (2) gained by the curve fitting is the solution of the differential equation

$$\frac{dL_{\chi'}}{dv_{trav}} = 2rv_{trav} (L_{\chi'_{\max}} - L_{\chi'}) \quad (3)$$

with the initial condition  $L_{\chi'}(0) = 0$  which was indirectly obtained. This can be considered as the law revealing accurately the relation between the degree of loosness and the travel speed of the tractor-implement combination. The variables of the differential equation can be separated so its solution is as follows [2].

$$\int_0^{L_{\chi'}(v_{trav})} \frac{dL_{\chi'}}{L_{\chi'_{\max}} - L_{\chi'}} = 2r \int_0^{v_{trav}} v_{trav} dv_{trav} \quad (4)$$

$$\left[-\ln(L_{\chi'_{\max}} - L_{\chi'})\right]_0^{L_{\chi'}(v_{trav})} = 2r \frac{v_{trav}^2}{2} \quad (5)$$

$$\ln(L_{\chi'_{\max}} - L_{\chi'}(v_{trav})) - L_{\chi'_{\max}} = -rv_{trav}^2 \quad (6)$$

$$\ln \frac{L_{\chi'_{\max}} - L_{\chi'}(v_{trav})}{L_{\chi'_{\max}}} = -rv_{trav}^2 \quad (7)$$

$$\frac{L_{\chi'_{\max}} - L_{\chi'}(v_{trav})}{L_{\chi'_{\max}}} = e^{-rv_{trav}^2} \quad (8)$$

$$L_{\chi'_{\max}} - L_{\chi'}(v_{trav}) = L_{\chi'_{\max}} e^{-rv_{trav}^2} \quad (9)$$

$$L_{\chi'}(v_{trav}) = L_{\chi'_{\max}} - L_{\chi'_{\max}} e^{-rv_{trav}^2} \quad (10)$$

$$L_{\chi'}(v_{trav}) = L_{\chi'_{\max}} \left(1 - e^{-rv_{trav}^2}\right) \quad (11)$$

After the evaluation of the experiment, it can be affirmed that the exponential function (2) describes the phenomena in a realistic way. The physical explanation from the course of the curve is that there is an upper limit of the increase in the loosness performed by increasing the travel speed of the tillage combination as well, in any of conditions. The level of the upper limit is influenced by the properties of the soil as well as the combination. In the case of continuous operating at this 'maximum' travel speed, the value of the loosness can be considered constant to a close approximation.

However, the roughening of the surface of the loosened soil attends the intensive increase of the loosness degree which is indicated by the corollary increased deviations of the measured values ( $s_{a1}$ ) – due to the bigger and bigger clods appearing on the surface.

## Conclusions

On the base of the results and experiences of the measurement tests, results can be stated as follows:

- It has been proved that the measurement of loosness based on the detecting of electrical conductivity is a process providing correct data also for clayey loamy soils in the actual test conditions.
- The intensive effect of the travel speed of the tractor-implement combination upon the degree of loosness can be proved by the novelty-like loosness measurement.
- According to the results, the differential equation (3) gained indirectly can be considered as the fundamental law defining the relationship between the degree of loosness  $L_{\chi'}$  and the travel speed of the tilling combination.
- The solution of the differential equation (3) results in the exponential function (2) gained by curve-fitting.

## References

- [1] ARWED, S.: Die Messung der Leitfähigkeit als Maß für die Dichte des Bodens, Landtechnik, Kuratorium für Technik und Bauwesen in der Landwirtschaft, Darmstadt, 2005, p. 264-265
- [2] KÓSA A.: Közönséges differenciálegyenletek, Szent István University, Gödöllő, 2007, p. 1-257
- [3] SITKEI GY.: A mezőgazdasági gépek talajmechanikai problémái, Akadémiai Kiadó, Budapest, 1967, p. 75-76
- [4] B. BOYDELL, A. MC. BRATNEY, B. WHELAN & BUDI-MAN: Preliminary results with the VERIS soil electrical conductivity instrument. Australian Centre of Precision Agriculture, University of Sydney, 2007. [www.usyd.edu.au/veris](http://www.usyd.edu.au/veris)

# DESIGN OF AXIAL FLOW FAN ROTOR WITH CONSTANT BLADE CHORD METHOD

Dániel FENYVESI - Ferenc SZLIVKA  
Szent István University, Gödöllő

## Objective

In the course of design, that one angular momentum ( $r \cdot v_{3u}$ ) is looked for, which satisfactory to the selected ( $Q, \Delta P_t$ ) global design twin number. Accordingly to Euler turbine equation, the angular momentum at given radius proportional to the total ideal pressure difference on the same radius (eq. 1.):

$$\Delta P_t(r) = \rho u v_{3u} \quad [1]$$

Simplifying assumptions are considered, which are reasonable for fan rotors with no inlet guide vanes:

- Incompressible flow through the rotor.
- Swirl-free inlet flow,  $v_0(r) = \text{const.}$

## The step of axial rotor design

1. The calculation of velocity triangles.

In this case the NfV method is chosen.

2. The calculation of rotor grid.

In this case the 2D cascade measurement method is chosen.

The adopted design method relies on the classical assumption of cylindrical stream tubes through the rotor, therefore the radial rearrangement of interblade flow ("secondary flow") is implicitly neglected in design.

## Methods and materials

The absolute tangential velocity distribution at the downstream of the rotor is suitable to choose as a power function (eq. 2.) [2]:

$$v_{3u} = k \cdot r^n \quad [2]$$

Special values of angular momentum exponent (n) (Table 1.):

Table 1. [2]

	n = -1	n = 0	n = 1
$v_{3u}$	hyperbolic	const.	linear
$r \cdot v_{3u}$	const.	linear	parabolic

The (k, n) twin values needs to be suffice the following two auxiliary conditions.

Continuity-equation (eq. 3.) [2]:

$$Q = 2\pi \int_{r_i}^{r_a} v_{3m}(r) \cdot r dr \quad [3]$$

Performance-equation (eq. 4.) [2]:

$$\overline{\Delta P_t} = \frac{2\pi}{Q} \int_{r_i}^{r_a} v_{3m}(r) \Delta P_t(r) \cdot r dr \quad [4]$$

The differential equation of cascade flow is become when the Bernoulli-equation was derived at given radii (eq. 5.) [2]:

$$\frac{d(u \cdot v_{3u})}{dr} = \frac{1}{\rho} \frac{dp_3}{dr} - \frac{1}{\rho} \frac{dp_0}{dr} + \frac{1}{2} \frac{d(v_3^2)}{dr} - \frac{1}{2} \frac{d(v_0^2)}{dr} \quad [5]$$

The meridional velocity ( $v_{3m}$ , Fig. 1.) at the downstream of rotor is achieved when the eq. 5. was integrated between the blade hub and blade tip as function of radius (eq. 6) [2]:

$$v_{3m}^2(r) = \frac{n+1}{n} k^2 [r_a^{2n} - r^{2n}] - 2k\omega [r_a^{n+1} - r^{n+1}] + v_{3ma}^2 \quad [6]$$

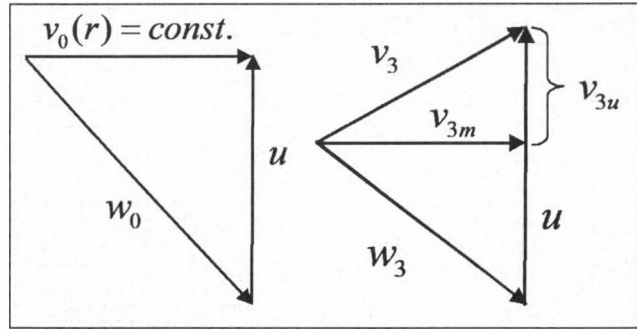

Figure 1 Inlet and outlet velocity triangles at given radii

The meridional velocity is unknown at the blade tip, it is determined with the help of continuity equation. During the calculation the (k, n) twin variables and ( $v_{3ma}$ ) necessary to iterate on account of constant chord length. So thus the solution require triple iteration during the calculation (Fig. 2.) [1].

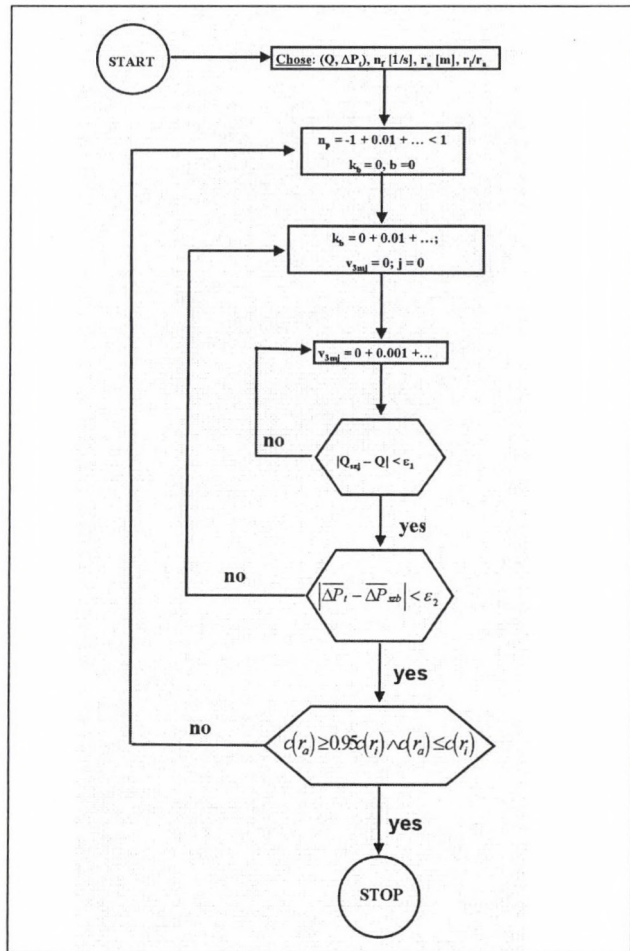

Figure 2 Block diagram of iteration

## Calculation of rotor cascade

The blade to blade flow is assumed for several stream surface segments, therefore classic 2D stationary cascade measurement

data was used during the design. The relative solidity ( $s/c$ ) reads, Howell [1] (eq. 7.):

$$\tan \alpha_0 - \tan \alpha_3 = \frac{1.55}{1 + 1.5(s/c)} \quad [7]$$

The optimum deviation angle as proposed McKenzie [4], on the basis of experimental data (eq. 8.):

$$\delta = (1.1 + 0.31\theta)(s/c)^{1/3} \approx \delta_{\text{Howell}} + 2^\circ \quad [8]$$

There is according to Cumpsty's experiences [3].

### Result and discussion

The input rotor design parameters are:

$$\begin{aligned} \Delta P_t &= 588 \text{ Pa} & r_a &= 315 \text{ [mm]} & N &= 16 \text{ [pc. of blade]} \\ Q &= 3.36 \text{ [m}^3\text{/s]} & r_i &= 213 \text{ [mm]} & n_f &= 1200 \text{ [1/min]} \end{aligned}$$

At the end of the iteration obtained:

$$k = 8.2 \quad n = -0.4 \quad v_{3m} = 19.8 \text{ [m/s]}$$

The selected blade type is C4. The C4 blade profile is very popular at low speed compressor rotor application. The calculated rotor is showed at Fig. 3. and the local theoretical  $\varphi$  and  $\psi$  distribution are represented in Fig. 4.

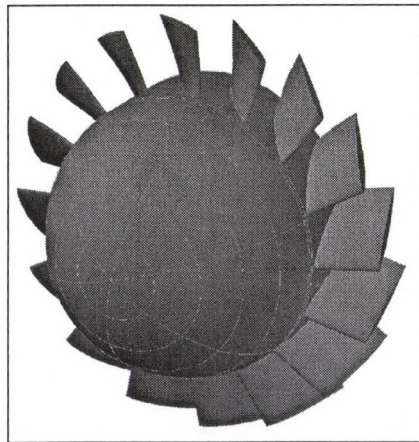

Figure 3 Calculated axial rotor

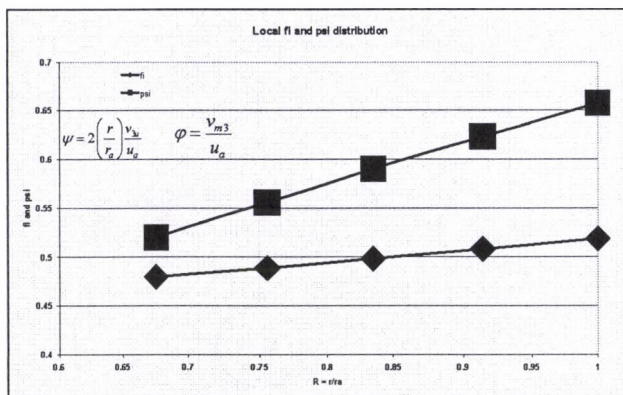

Figure 4 Local theoretical  $\varphi$  and  $\psi$  distribution

### Conclusion

The presented method make it possible the high grid density rotor design. The showed design method constitute the basis of blade distortions (dihedral, sweep, and lean blade geometry modification) and comprehensive CFD interblade flow analysis in the cause of better rotor hydraulic efficiency.

### References

- [1] Wallis, R. A.: *Axial flow fan*, George Newnes Limited, London, 1983;
- [2] Somlyódy L.: *Axiálventilátorok tervezése és jelleggörbeszámítása*, Műszaki doktori értekezés, BME, 1971;
- [3] Cumpsty, N. A.: *Compressor aerodynamics*, Longman Scientific & Technical, NY, 1998;
- [4] McKenzie A. B.: *The selection of fan blade geometry for optimum efficiency*, Proc. Instn. Mech. Engrs., IMechE., London, 1988.

### Nomenclature

$v$	[m/s]	: absolute velocity
$c$	[m]	: blade chord
$s$	[m]	: blade pitch
$k$	[-]	: angular momentum constant
$\alpha$	[deg]	: angle of relative velocity at axial direction.
$Q$	[m <sup>3</sup> /s]	: mass flow rate
$\Delta P_t$	[Pa]	: global total pressure difference
$\bar{\psi} = 2\Delta P_t / \rho u_a^2$	[-]	: global total pressure rise coefficient
$\psi_i = (2Rv_{3m}) / u_a$	[-]	: local total pressure rise coefficient
$u$	[m/s]	: peripheral speed
$n$	[-]	: angular momentum exponent
$w$	[m/s]	: relative velocity
$r$	[m]	: radius
$R = r/r_a$	[-]	: non-dimensionalized radius
$\bar{\varphi} = v_0 / u_a$	[-]	: global flow coefficient
$\varphi = v_{3m} / u_a$	[-]	: local flow coefficient
$n_f$	[1/s]	: rpm
$b, j$	[-]	: constants of iteration
$\epsilon_{1,2}$	[-]	: error limitation of iteration
$\delta$	[deg]	: angle of deviation
Index		
0		: inlet
3		: outlet
i		: blade hub
a		: blade tip
m		: meridional

## ANALYSIS OF THE DRYING TECHNOLOGY OF OIL SEEDS AND CORN KERNELS

Jenő CSERMELY - Mihály HERDOVICS - József DEÁKVÁRI  
Hungarian Institute of Agricultural Engineering, Gödöllő

### Aims, material and method

Drying technology analysis was carried out with some oil-seed such as canola, sunflower, mustard and grape kernels, furthermore that of some cereals and corn, respectively. These researches were arranged in the laboratory of the MGI, where harvesting moisture content and drying temperature ranges were analyzed.

### Results and discussions

Three drying medium temperature (70, 80, 90°C) were applied during **canola drying** with  $p = 120$  Pa fan pressure,  $V = 280$  m<sup>3</sup>/h air transport,  $G_1 = 30$  kg wet material mass and 20 cm layer depth of drying material. Average 1000 kernel mass of the analyzed corn was 5,72 g, and the drying chamber's diameter varied between 1,9-2,2mm. The drying velocity was 8,8 moisture %/h besides  $t = 90^\circ\text{C}$  drying air temperature, between 17,2-4,0% moisture range, it was  $V_{dr} = 8,0$  moisture %/h besides  $t = 80^\circ\text{C}$  drying air temperature, and the drying rate was  $V_{dr} = 7,1$  moisture %/h at  $t = 70^\circ\text{C}$  drying air temperature. In this case the water evaporation capacity varied in descending order of the above-mentioned temperature, which showed 2,38 - 2,26 and 1,92 kg water/h values (Figure 1). On this base it can be stated, that 10°C temperature difference causes 10% variation in the drying rate and the water vaporization capacity, too. The batch volume of the canola changed under drying like a quadratic polynom between the 3,6-18,8% moisture range. Its maximum is traceable near its equilibrium moisture content at 7-8%, which means 645 kg/m<sup>3</sup>. Canola endured 4,7% shrinkage during drying, which comes out to the one-third as that of the corn. Shrinkage practically terminates near to the moisture equilibrium content.

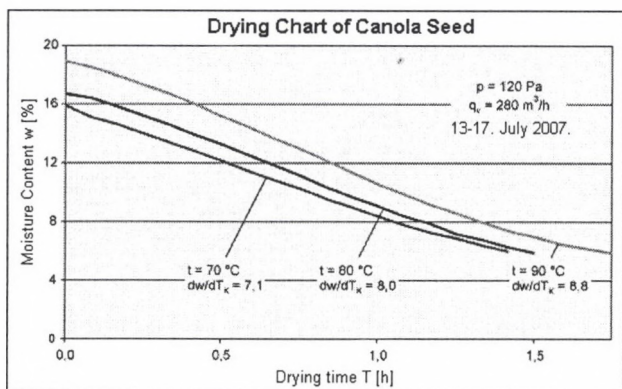

Figure 1

60°C and 100°C drying medium was applied during **sunflower drying** with  $p = 280$  Pa fan pressure, 430 m<sup>3</sup>/h air transport and  $v = 0,4$  m/s air velocity. The wet mass of the drying material was  $G_1 = 20$  kg, the layer depth was 20 cm, and the average 1000 kernel mass was 65 g.

Drying process of sunflower with  $w_1 = 21\%$  moisture content was divided into two phases. In the first one the temperature was 100°C, where the drying was stopped at  $w_2 = 12\%$ . In this case the drying rate was 6,77 moisture %/h. In the second one (Figure 2) the drying was continued from  $w_2 = 12\%$  - this is the usual harvesting moisture content - and it was dried with 60°C drying air till  $w_2 = 4,5\%$  moisture content, where the drying rate reached the 10,0 moisture %/h. This allows us to say a very

notable conclusion in the case of the applied drying technology of the sunflower; therefore the analyses will be continued. In the second measurement series the product with  $w_1 = 9,0\%$  moisture content was dried - according to the desiccation - by  $t = 60^\circ\text{C}$  drying medium down to 4,9% moisture content. This drying resulted in an average 7,1 moisture %/h drying rate. Volume mass of the sunflower was between 379-399 kg/m<sup>3</sup> within the analyzed moisture range.

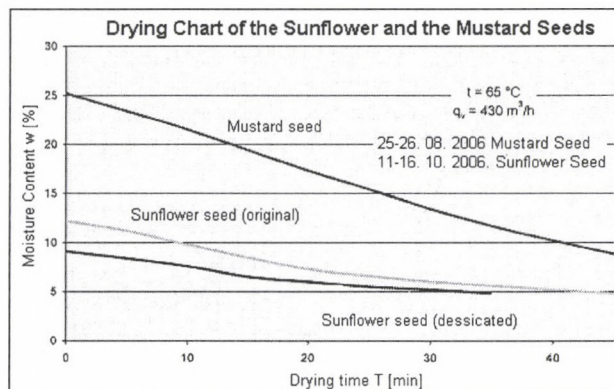

Figure 2

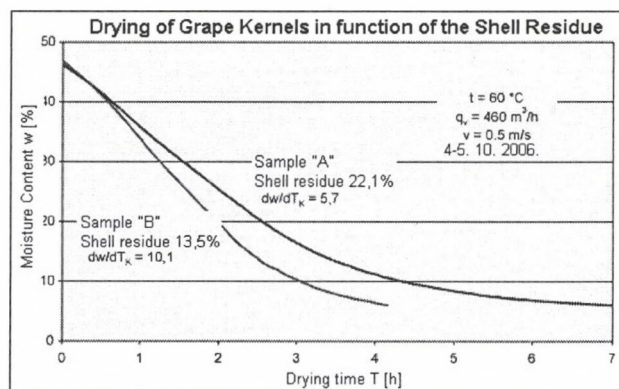

Figure 3

Drying of **grape kernels** was carried out with differently cleared „A” 22,1% and „B” 13,5% (shell residue) material. Sample mass was 30-30 kg, the layer depth 20-20 cm, drying air temperature 60°C and 65°C. The grape kernel contamination (ratio of shell residue) had significant influence on the drying time and energy demand of drying. The drying time increased with about 75% as well as the energy consumption by about 40% in the case of samples with 13,5% and 22,1% contamination. Drying time of „A” samples with 46,2% moisture content and 22,1% shell residue contamination was about 7 hours where 60°C drying air was used, if it was dried down to 6,5% moisture content (Figure 3). Evaporation of 12,9 kg water was carried out with 5,7 moisture %/h drying rate and 1,84 kg water/h specific water removal. Initial moisture content of sample „B” was 46,8% with 13,5% contamination. This drying down to 6,5% moisture content took about 4 hours with 65°C drying medium temperature. In first case the drying rate and the specific water removal increased significant because of much less shell residue. Its values rose up to 10,1 moisture %/h and 3,25 kg water/h. Mass ratio of the contamination was decreased from 22,1% to 18,1%, and from 13,5% to 12,2%, respectively, which comes from the higher initial moisture content of the shell residue. **Every additional 1% contamination growth results in further 18-20 minutes drying time** within the given 13-22% range of shell residues, which deteriorates the dryer performance and the energy consumption. The main aim should be to reach the maximum

10% contamination content during the pre-filtration stage, and in this case – and besides 65°C drying medium – the drying time could be decreased to 3 hours.

Drying of **mustard seed** was carried out by industrial circumstances, with CIMBRIA BEG-8R grain dryer equipment, which is a cross-flow chamber dryer with persistent operation, where the sucked cooling air can be remixed. Quantity of the drying air is 40,000 m<sup>3</sup>/h, and that of the remixed cooling air is 28,000 m<sup>3</sup>/h. The water evaporation capacity of this equipment was 380 kg water/h by mustard seed with 14% harvesting moisture content dried until 6%. Its dried material performance was 4.1 t/h. 60°C drying medium was used during mustard seed drying, where the value of the specific heat energy consumption was 3,8 MJ/kg water, which is a good feature of that.

Temperature of the mustard seed did not reach the 50°C; the smoothing of the drying – which followed that of the heat- and mass transfer – was 6,0 ± 0,2 %, which is a prosperous value. Laboratory-scale drying results can be seen in **Figure 2**.

55°C; 70°C and 75°C drying medium was used during **corn kernel** drying with  $v = 0,225$  m/s drying air velocity and an average 19,3% initial moisture content (**Figure 4**) There was a big difference between the drying rates. Average drying rate at 55°C temperature level was 2.28 moist. %/h, that at 75°C was 7.48 moist. %/h. Maximal drying rate values were in order of the temperature steps 5.0, 8.5 and 10.1 moist. %/h, respectively. **In the given range every 1°C raise of temperature resulted in 5 minutes shortage of the drying time and proportionately the energy consumption.**

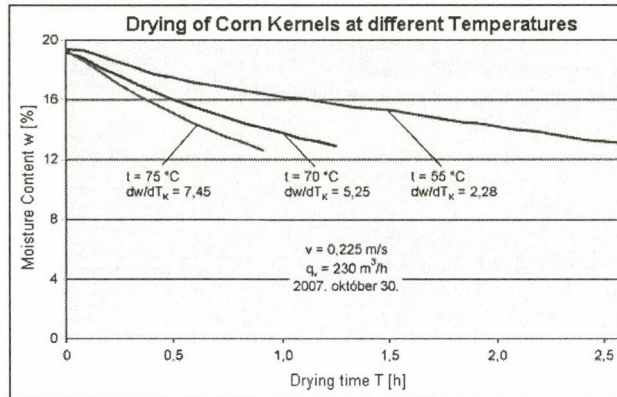

Figure 4

# INCREASING THE SOLUBLE ORGANIC MATTER CONTENT AND BIOGAS PRODUCT OF SEWAGE SLUDGE BY MICROWAVE PRETREATMENT

Sándor BESZÉDES - Zsuzsanna LÁSZLÓ - Szabolcs KERTÉSZ  
- Gábor SZABÓ - Cecilia HODÚR  
Faculty of Engineering, Department of Technical and Process Engineering, Szeged

## Objective

A large scale development was experienced in the last few decades in the water management technology and hereby the cleaning efficiency could be in a large measure improved, but simultaneously the quantity and the environmental risk of emitted sewage sludge increased. The sewage sludge is the residue of the primary, secondary or tertiary wastewater management technologies. However sludge represents the major solid waste from biological and physico-chemical waste water treatment processes.

The main structure of sludge consists of an extracellular polymeric substance (EPS), other organic and inorganic matter and microbial cells which agglomerated together and formed a special type of floc structure. In the case of biological originated sewage sludge the cohesive force are greater than mineral floc, in consequence of bridging by negatively charged EPS and multivalent cations such as  $\text{Ca}^{2+}$  and  $\text{Fe}^{3+}$ . The polymeric structure originate from the compounds of raw wastewater, cell autolysis and sludge bacterial cell and the cationic content of dosed chemical. This complex floc structure of sludge is resistance to a direct aerobic or anaerobic degradation since cell walls of microorganisms and the polymeric conformation present physical and chemical barriers for microbial and enzymatic degradation. EPS is present in varying quantities in different sewage sludge often occurring as a highly hydrated capsule surrounding the cell wall of microorganisms and loose in solution as slime polymers [1].

The commonly used methods for sludge treatment are digestion, agricultural using, composting or dumping. Before following utilization sludge has to be stabilized in order to decrease environmental risk. The thermal treatments are the most commonly used process to sludge stabilization. The heat pretreatments improve pathogen destruction and dewaterability of sludge, modify the structure of sludge and transform a part of suspended organic solids into soluble compounds [2]. Result of thermal hydrolysis of macromolecules amino acids, volatile acids and simple sugars are produced, so a considerable increasing of chemical oxygen demand (COD) can be experienced in the water soluble phase [3]. Anaerobic digestion is a common way to stabilize the organic matter of sludge and this biological process has not negligible benefit, production of biogas, which is a renewable energy source.

The microwave radiation is an alternative technique for sludge treatment. Due to high water content the sewage sludge can absorb microwave energy efficiency. Because of rapid internal heating and selective heating effects, the cell walls of both dead and living microorganisms in sludge are destroyed. In consequence of non-thermal effect of microwave radiation polarizing of macromolecules could be experienced, it results breakage of hydrogen bound [4]. Therefore the microwave irradiated microbial cell shows greater damage than convective heating cells to a similar temperature. The intensive microwave heat generation and the different dielectric properties of compounds of cell wall lead to a rapid disruption of extracellular polymer network and residue cells of sludge [5]. However the cell liquor and extracellular organic matter within polymeric network can release into the soluble phase [5]. Hereby increase the ratio of accessible and biodegradable component and the biogas yield [6] [7].

## Methods and Materials

The sewage sludge was originated from a industrial waste water treatment plant of a local dairy works (Sole-Mizo Ltd., Szeged, Hungary). In the case of dairy industrial sewage sludge a physico-chemical waste water technology was applied and after a pre-squeezing the final average water content of sludge was 58,2 w/w%.

The chemical oxygen demand (COD) was measured before and after the treatments, by the dichromate standard method, in COD tests with an ET 108 digester and a PC Checkit photometer (Lovibond, Germany). In order to determination of water soluble organic matter content before COD measurement the samples were centrifuged for 20 minutes at 6000 RCF, and the separation of water soluble phase a 0,45  $\mu\text{m}$  pore size disc filter (Millipore) was used. The original chemical oxygen demand of the sludge was 398,6  $\text{kg m}^{-3}$ .

The biochemical oxygen demand (BOD) measurements were carried out in a respirometric BOD meter (BOD Oxydirect, Lovibond, Germany), at 20 °C. To ensure the consistency of the results, standard "BOD Seed" aerobic microbe capsules (Cole Parmer, USA) were used in the measurements. The aerobic biodegradability during 5 days ( $\text{BD}_5\%$ ) was calculated the following equation

$$\text{BD}_5\% = (\text{BOD}_5 / \text{COD}) \times 100$$

where  $\text{BOD}_5$  is the biochemical oxygen demand (oxygen consumption) during 5 day

The microwave treatment was performed in a Labotron 500 professional microwave equipment (Buchner-Guyer AG, Switzerland) at 2,45 GHz frequency. The microwave irradiation time was 10 to 40 minutes. The applied specific microwave power level was 1, 2, 5 and 10 W/g, which was adjusted by the ratio of magnetron power and the quantity of treated sludge.

Biogas production tests were performed triplicated in batch mode under mesophilic conditions, at 30°C for 30 day, in an anaerobic laboratory digester with a pressure measuring head (Oxitop Control AN12 measurement system, WTW GmbH, Germany). The capacity of digesters was 1000 mL, the volume of diluted sample was 200 mL, the dry content of sludge was adjusted to 6 % with sterile water. The digester was inoculated with acclimated sludge from a biogas reactor of a municipal wastewater treatment plant (Hódmezővásárhely, Hungary) in order to eliminate the possible lag-phase of anaerobic biological degradation process. For methane determination, measurements were performed in parallel in two vessels: one of them contained a  $\text{CO}_2$  absorber, while the other measured the total biogas pressure. In addition the accurate composition of the biogas produces was measured by gas chromatographic and mass spectrometric method (Agilent 6890N-5976 GC-MS).

## Results and discussion

In the first series of our experiments the effect of microwave irradiation on solubility of organic matter content of dairy originated sludge was determined.

The microwave treatments could enhance more efficiently the quantity of water soluble organic matter than conventional heat treatment at 95°C. In the case of high specific power levels (5 and 10 W/g) increasing was approximately quintuple and after 30 minutes treatments saturation values were observed (Fig. 1). This effect can be explained by the degradation of extracellular polymeric network and disruption of cell wall of dead and alive microorganisms.

By the following measurements the effect of microwave irradiation on biodegradability was examined at different specific microwave power level. The biodegradability of untreated dairy originated sewage sludge was 7%. The structure

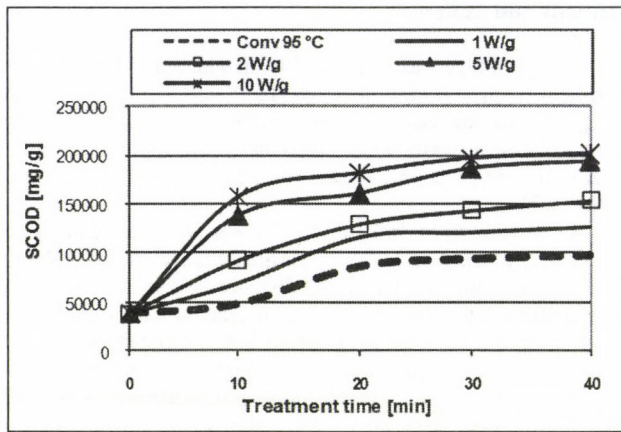

Figure 1 The changes of solubility of organic matter content after microwave and convective treatments

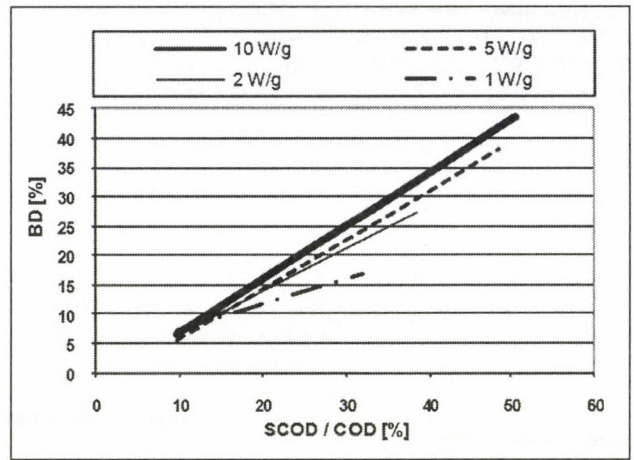

Figure 3 Connection between solubility and biodegradability

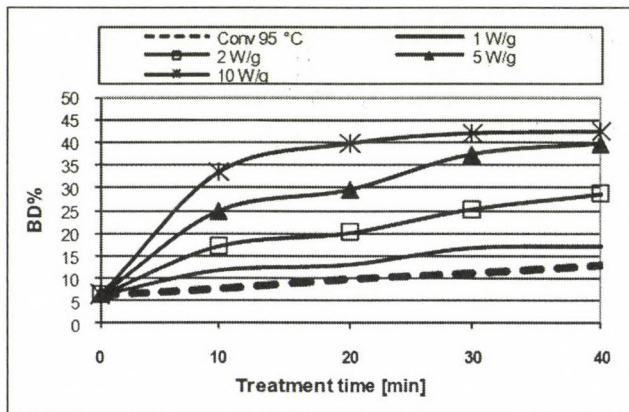

Figure 2 The effect of microwave pretreatments on biodegradability (BD%)

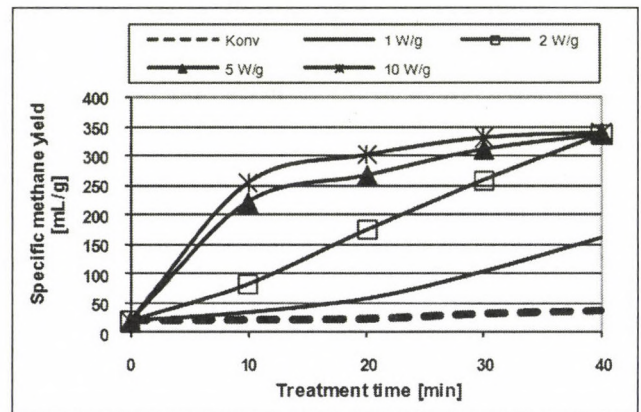

Figure 4 Specific methane yield after microwave pretreatments

of sludge, formed by interaction of extracellular polymeric substance and residual chemicals, caused less accessible property for biological decomposition.

Microwave treatments at low power level (1 W/g) had small effect on the ratio of biodegradable and total organic matter, but the higher microwave power level and enhanced irradiation time seemed to be more efficiently. Similarly to solubility of organic matter content the convective treatment at 95°C caused increasing in biodegradability, but this effect was less effective than pre-treatment at lowest microwave power level. (Fig. 2). At highest applied power level (10 W/g) a saturation value of biodegradability was observed.

Enhancing of biodegradability may be linked to solubilization of organic matter which was indicated by the increased sCOD/COD ratio. In order to examine the effect of solubility on biological decomposition the biodegradability was plotted against the ratio of soluble and total organic matter content (Fig. 3.). The water-solubilization of organic component was characterized by the ratio of soluble COD (SCOD) and total COD.

In the case of studied microwave pretreatment a linear connection was observed between the solubilization and the change of biodegradability. Because of thermal and athermal effect of microwave radiation the structure of sludge modified and the increased solubility of organic matter made sludge more accessible for microbial degradation.

Beside the change of solubility and biodegradability, the effect of microwave irradiation on anaerobic digestion was investigated. The digestionability was characterized by cumulative specific methane production during 30 days fermentation period.

Similar to aerobic biodegradation the microwave pretreatment could improve the performance of anaerobic digestion and the increased irradiation time enhanced the biogas- and methane

production of pre-treated sewage sludge related to control. The non-treated control sample had a small methane production (18 mL), but the microwave pretreatment improved the anaerobic decomposition efficiency and therefore after 40 minutes treatment at 10 W/g power level the specific methane yield could be enhanced to 340 mL/g. The higher specific microwave power caused a higher increasing in biogas production and however higher decreasing in period of lag-phase of digestion. But after 40 minutes pretreatment there was no significantly difference between the effect of 2, 5 and 10 W/g specific power levels (Fig. 4). By short time pretreatments the increasing of microwave power level from 2 to 5 W/g caused a great enhancing in methane product. In the case of methane product was smaller difference between the effects of 5 and 10 W/g treatment than in the case of aerobic biodegradability.

## Conclusion

Our work focused on the effect of the microwave pretreatments on the solubilization of organic matter, aerobic biodegradability and biogas product of sewage sludge. Our results showed that the microwave irradiation could be an efficiently process in sewage sludge handling. It was observed, that originally resistant sludge after a microwave pretreatment became more degradable. By applying of microwave radiation the solubility of organic matter content increased and therefore the aerobic biodegradability and biogas product enhanced.

## Acknowledgement

This work was supported by the Hungarian National Office of Research and Technology (NKTH) and the Agency for Research Fund Management and Research Exploitation (KPI)

under contract No. RET-07/2005, and GVOP 3.2.1.2004-04.0252/3.0 project.

#### References

- [1] Neyens, E. - Baeyens, J. - Dewil, R. - DeHeyder, B.: „Advanced sludge treatment affects extracellular polymeric substances to improve activated sludge dewatering”. *Journal of Hazardous Materials, Vol. 106B*, pp. 83-92., 2004
- [2] Stasta, P. - Boran, J. - Bebar, L. - Stehlik, P. - Oral, J.: „Thermal processing of sewage sludge” *Applied Thermal Engineering, Vol. 26*, pp. 1420-1426., 2006
- [3] Bougrier, C. - Delgenes J., P. - Carrere, H.: „Effects of thermal treatments on five different waste activated sludge samples solubilisation, physical properties and anaerobic digestion” *Chemical Engineering Journal, Vol. 139*, pp. 236-244., 2007
- [4] Wojciechowska, E.: „Application of microwaves for sewage sludge conditioning” *Water Research, Vol. 39*, pp. 4749-4754., 2005
- [5] Beszédes S. - Kertész Sz. - László Zs. - Hodúr C. - Szabó G.: „Biogas production of ozone and/or microwave pretreated canned maize production sludges” *Proceedings of Sustainable Agri-Food Industry Use of Ozone and Related Oxidants International Conference. Valencia, Spain.*, p. 2.3. 1-6 (2007)
- [6] Eskicioglu, C. - Kennedy K., J. - Droste R., L.: „Characterization of soluble organic matter of waste activated sludge before and after thermal pretreatment”. *Water Research, Vol. 40*, pp. 3725-3736., 2006
- [7] Beszédes S. - Kertész Sz. - László Zs. - Géczy G. - Hodúr C. - Szabó G.: Sewage sludge treatment by microwave energy. *Proceedings of 5th International Congress on Food Technology*, pp. 441-446., (2007)

# TECHNICAL-ECONOMICAL CHARACTERISTICS OF MACHINE UTILIZATION IN THE DIFFERENT BRANCHES OF CROP FARMING CONSIDERING PLANT SIZE

László MAGÓ

Hungarian Institute of Agricultural Engineering, Gödöllő

## Introduction

Work done by an efficiently developed machine system is a significant condition of the fruitfulness of farming. The machine prices and the cost of their utilization are extremely high and all these result in extraordinarily high production costs. *Rational machine utilization* is a definitive factor of the efficiency of venture-farming. According to our experiences the machine stock of a venture and the way and rate of utilization of same are reserves which can substantially contribute to the increase of corporate income (Husti 1999). [6]

Contrary to former practice the concept of "optimal machine system" is not to be interpreted within the framework of corporate enterprise only but we are to find a solution for solving the mechanization problems and planning the machine utilization of *small and medium size* farms as well (Hajdú-Gockler 2005). The wide range of enterprise sizes characteristic nowadays and the great number of power and working machine types available are also to be considered. Most of the machine producers already have power machine lines holding *the total performance scale as well as all the harvesting functions* (Hajdú-Magó 2004). Consequently, instead of planning a power machine system characterised by specific machine types the creation of a machine system determined by *performance category and function* is sufficient. This can be realized by any *machine type ad-libitum* according to the local facilities and production circumstances. A further important point is, that the planning of mechanization cannot be limited to determining the number of machines. There is a rightful demand for the determination and consideration of the economic parameters of the power and working machines of different types and performance categories developed by diverse enterprise sizes. The acquisition and afterwards use of valuable equipment necessitates well-grounded economic decisions (Fenyvesi et al. 2003) (Takácsné György-Takács 2003). [2; 4; 5; 15]

All the above apply first of all to *power machines* as those need closer attention due to their high acquisition and utilization costs (Savin 2004). The aim is, therefore, to promote the development and utilization of an efficient power machine stock. This can be achieved by a mechanization model considering the present property structure, the wide selection of machines, the utilization cost level of diversely exploited power machines, and, furthermore, which is apt to determine the structure, investment- resp. utilization costs of a machine system composed of the power machines of different machine families adaptable to diverse farm size with the lowest utilization costs. [14]

Considering the shift-hour performance of the machines under given production circumstances an overall system for building up a machine system adapted to small, medium and large farm size can be developed. The *areal size limits and cost of the utilization* of self-owned power machines of different performance level and harvesting machines of diverse functions can be determined as well as the *number of shift-hours to be performed* which also effects the efficiency and cost of machine utilization. In case of power machine families representing different quality, resp. cost level the cost level of the given power machines carrying out the individual work operations at different farm sizes can be determined.

The present study is a comprehensive survey covering the analysis of the development of the machine stock and the use of the machines of field crop producing, field vegetable growing

and plantation cultivating farms by the application of the means of computer-guided modelling. The characteristics of the machines demanded by the production of different plants are taken into account and special attention is paid to the application of machines with reasonable capacity and technical level in respect of cost by different farm sizes.

Our aim is to stipulate the range of farm size under which the development and operation of an own machine stock is not even with additional machine cost offering worth in the branches surveyed. By this the farm size limit under which the use of the logistically more defenceless lease work is reasonable in order to keep the cost of machine work at an acceptable rate will be defined. This limit varies from branch to branch. This way the fact that the mechanization of the individual branches is highly dependent from the farm size and the diversity of parameters effecting mechanization can be pointed out.

## Method

### *The significance of machine utilization*

In the utilization costs of the more and more up-to-date and expensive power machines the proportion of *fixed costs*, especially amortization and maintenance is very high. This expense can be decreased by increasing *utilization*. If the applied means are coupled to the individual field work operations at their effective operation cost – i.e. taking the rate of utilization into account – the effect of *shift-hour performance* on costs will become measurable.

### *The crop growing branches surveyed*

The surveys can be conducted by *modelling* the machine working processes of agricultural production. In the case of field crop production a crop plan including cereal plants for human consumption, maize for animal breeding and for energy production purposes and oil seeds – as sunflower and the nowadays very popular crucifer – appropriate for human consumption and energy production as well and reflecting the special features of production in Hungary has been applied. Our calculations have been based on a crop plan including cereal plants, sweet corn, onion and root vegetables in case of field vegetable growing while in case of plantation cultivation the data of a vine growing farm have been taken into account. Depending on farm size the proportion of the crop area of the individual plants has been stipulated in view of the agronomical and production technological conditions.

### *The machine families applied, the parameters of model calculations*

Basically the cheapest power machine families used in Hungary on the one hand and the ones with the highest possible investment cost demand available on the market of agricultural machinery on the other have been the subject of the survey. While in case machines with low historical cost the costs of machine utilization are low as well owing to the meagre amortization cost, a substantial amortization cost is to be calculated in case of high price power machines. In the latter case the price difference can be compensated by the lower specific fuel consumption due to the more modern construction, the easy handling, the quality of work done, and the ergonomically more advantageous design. The life expectancy of the high investment cost machines is also longer. This can, though, not easily be denoted in figures as the life expectancy of a lower cost machine can be lengthened several times by a low cost overall renewal. The spare part costs of these machines-equipment are mostly favourable and the costs of the additional repairs are also not considerable on the whole compared to the purchase price of a modern machine.

The basic figures of machine utilization have been determined with the help of the data base of the Hungarian Institute of Agricultural Engineering. [3]

The *model-calculations* have affected the determinative farm size points of machine stock development in a farm size range of 2-1000 ha depending on branch. On this basis we can come to statements affecting a wider segment of the agricultural property structure, resp. to conclusions concerning mechanization and machine utilization.

## Results

### *The conclusions arising from the results of the model calculations concerning the composition of the power machine system and the shift hour performance of the power machines*

The multi-purpose power machines have been classified according to *engine performance* during the survey, moreover the self-propelled grain harvesting machine *function* has also been considered. The composition of the power machine systems assigned to the individual areas has been determined by *power machine categories*. Under given machine working conditions as sowing structure and production technology characteristic of the special features in Hungary *regular coherences* can be stated considering the composition by categories of a *cost efficient power machine system* developing according to farm size in different branches of plant production. (Magó 2000, 2008c, 2008d) [7; 11; 12]

The number of shift-hours achievable by different farm sizes effects the composition by category of the power machine system.

- In case of *field crop growing* considering the *smallest farm size (max. 50 ha)* the *utilization level* of the tractors is *low*: maximum 400-500 shift-hours annually.
- In case of *medium size farms (50-300 ha)* this quantity is *bigger*: 800-1400 shift-hours per year.
- In case of *large size farms (over 300 ha)* the performance (1000-1800 shift-hours a year) of the tractor categories is already significant. (Figure 1)

A grain harvesting machine with rationally chosen capacity achieves *good* utilization by farm sizes *over 300 ha* with a shift-hour performance of about 300/year and an *acceptable* operational cost hereby.

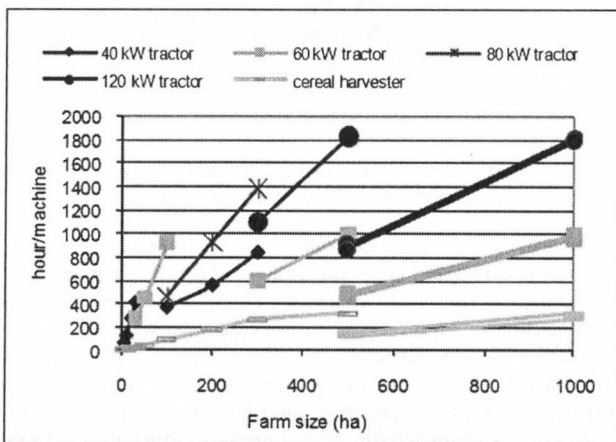

Figure 1 The shift-hour performance of power machine categories subject to farm size based on model calculations in case of field crop growing

The number of calculated shift-hours achievable in case of *field vegetable growing* subject to farm size is as follows: (Figure 2)

- By the smallest farm size surveyed (**max. 20 ha**) a *low level of utilization* of tractors can be achieved: maximum 500 shift-hours a year.
- In case of *medium farm sizes (20-100 ha)* the number of shift-hours is already remarkable: 500-1000 shift-hours per year.
- In case of *large farm sizes (over 100 ha)* the tractor categories may already have a significant performance (1000-1800 shift-hours per year).

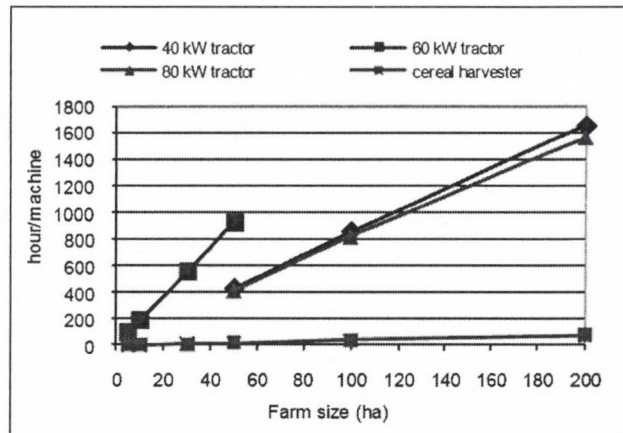

Figure 2 The shift-hour performance of power machine categories subject to farm size based on model calculations in case of field vegetable growing

The level of shift-hour performance by *plantation cultivation* (Figure 3)

- By the *smallest plantation sizes* surveyed (**max. 20 ha**) only a *low level of utilization*, maximum 600 shift-hours a year can be achieved even if a low capacity power machine is applied.
- In case of *medium and large size plantations (over 20 ha)* this quantity *grows* and the tractors may have a remarkable (600-1250 shift-hours annually) performance.

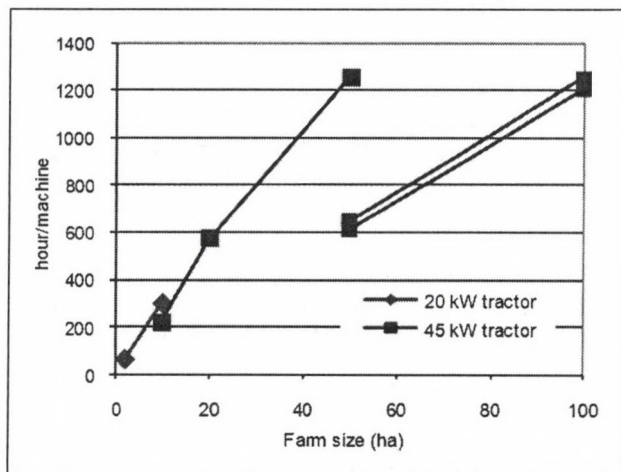

Figure 3 The shift-hour performance of power machine categories subject to farm size based on model calculations in case of plantation cultivation

The number of shift-hours per *unit of area* decreases with the increase of farm size. In case of *field crop production* on *small size farms* 10-15 shift-hour/ha/year is performed. In the size range of 30-300 ha a shift-hour performance of 8-10/ha can be calculated, *from this size on* an annual figure of about **6 shift-hours per hectare** becoming constant with the realization of an *efficient labour plan* can be observed. (Figure 4)

In case of *field vegetable growing* by the *small farm sizes* 20-25 shift-hours per hectare per year are realized. In the size range of

30-200 ha 18-20 sh/ha can be calculated but with the *increase of labour effectivity* even the favourable **15 shift-hours per hectare** performance can be achieved.

By **plantation cultivation** in case of *small farm sizes* 35-40 sh/ha can be achieved. In the size range of 10-50 ha shift-hours per hectare are performed, *from this size range on* the still significant annual figure of **24 shift-hours per hectare** becomes constant.

The above figures are characteristic of the utilization of the low investment cost power machines and they alter a bit if high investment cost power machine families are used. The more up-to-date power machine-working machine connections need shorter time for executing their labour tasks and this is also reflected in the above mentioned specific index. In field crop production, for instance the utilization of the more expensive and higher technical level results in a benefit of 0,3-0,5 shift-hour per hectare annually. But presuming internal home work only this benefit is a disadvantage considering utilization as the annual shift-hour performance of the individual machines decreases and hereby their specific utilization cost increases.

It can be stated that the most machine working hour demanding branch for the cultivation of one hectare is the plantation cultivation, field vegetable growing comes next, and the last one in the row is the field crop production. Obviously farms producing grain and oilseeds have the lowest machine working hour input demand. With the growth of the farm size the specific number of machine working hours necessary for the cultivation of one hectare area decreases in each branch and the figures are nearly halved in case work is done under more favourable and more efficient large scale farming conditions with high performance machinery.

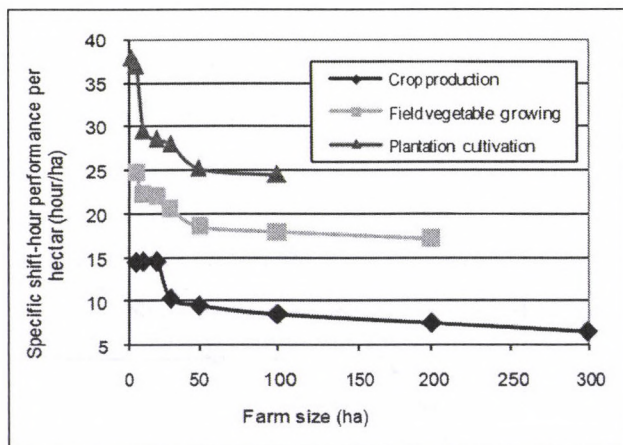

Figure 4 The total shift-hour performance of power machines subject to farm size in the different branches

The great number of hours experienced by small farm sizes increases the living labour expenditure as well. Though for farm of this size category the application of mainly low performance machines is characteristic due to the limited level of machine utilization the general expenses and, therefore also the operational costs are high (Nikolic-Savin 2007). [13]

#### The analysis of machine utilization- and investment costs subject to farm size

##### The machine utilization costs

The above are also proved by **Figure 5** which shows the lower and upper limit of machine utilization costs, resp. the most probable range of machine utilization costs of the different branches subject to farm size taking the application of low technical level power- and working machines as well as the

expensive power machines representing the most modern technology into account.

In general terms we can say that the low level of utilization by the small size farms generates the dominance of the fixed costs. Due to this fact the substantial differences between the amortization costs of cheap and expensive machines are also reflected in the cost of utilization. By medium size farms this tendency is already more moderate. By large farm sizes where the variable costs predominate in the cost structure of machine utilization owing to the notable shift-hour performance and the specific costs of fuel and wage costs are more favourable due to the fact that the machines are of a higher technical level and able to work more efficiently and with a better area performance the difference between the utilization costs of the cheap and the expensive power machines reduces, in some cases to the minimum.

Considering the above we can come to the conclusion that the variability of machine utilization cost tapers with the growth of farm size. In case of plantation cultivation where labour tasks are fulfilled by one or two nearby maximally utilized power machines by large farm size and machine harvesting is done by pulled harvester the cost interval gets quite narrow. Contrary to the above the maximal utilization of the self-propelled grain combine used in field crop producing and field vegetable growing farms can hardly be ensured even in case of large farm sizes and the high level of the operational costs of same tempers the "slimming" of the cost interval.

It can be stated that by the more working time demanding branches in case of large-scale farming the costs of machine utilization are less dependent on the technical and cost level of the appliances used and the machine costs assignable to the given area size and labour quantity can be determined more precisely.

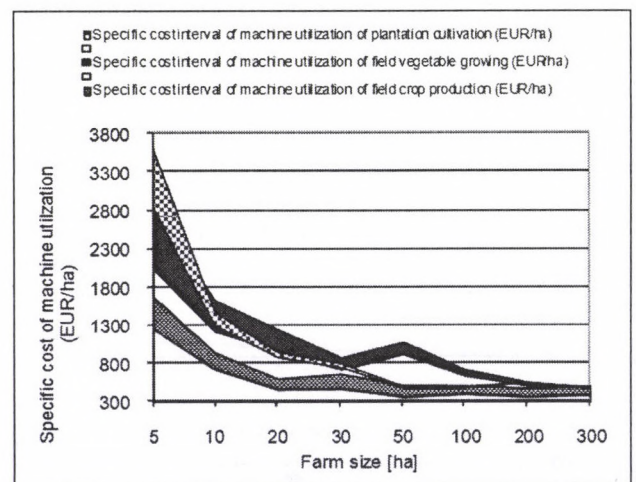

Figure 5 The interval of specific machine utilization costs in the different branches subject to farm size

The phases of increasing costs breaking the reducing tendency of machine utilization costs noticeable subject to farm size are attributable to the appearance of new higher performance machines at the given farm size. The capacity expansion of the machine stock is attached to the increase of machine performance. The arising idle capacity can be utilized by the further increase of the farm size and till then a local increase of fixed costs is characteristic of the machine utilization (Magó 2007). [8]

Surveying the decreasing tendency of machine utilization costs parallel with the increase of farm size it is clear that in case of real small-scale farming the machine costs are several times, three or may be even six-seven times higher than the acceptable and economically reasonable level of the medium, but

especially the large-scale farms. Consequently it can be stated that in spite of the reasonably chosen power machine capacity there is no technical solution which could acceptably solve the cost problem of farms smaller than about 16-20 ha in case of field crop production, 9-12 ha in case of field vegetable growing and 5-7 ha in case of plantation cultivation.

It must be pointed out that under the indicated farm size limits the development of an own machine stock is not economical if there is no lease-work possibility besides home labour whereby the machine utilization can be increased, the period of returning of machine investments can be shortened and a more fruitful farming can be achieved. (Baranyai et al. 2008). [1]

All the above can be even more specifically supported by demonstrating the specific costs of machine investment. By small farm sizes the specific costs of machine investment are obviously higher and their period of return is statutorily longer.

There is a possibility for the use of own machines also beneath the above mentioned farm sizes limits which do not ensure effective machine utilization. In this case the solution for the small-scale farms may be the operation of second-hand machines already over the amortization period which need close attention and are in many cases repaired by the owner personally (Magó 2007, 2008a). [9; 11]

#### The machine investment costs

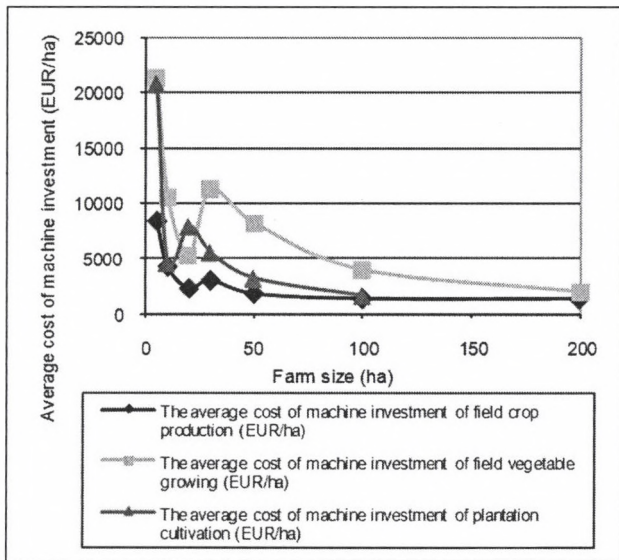

Figure 6 The conformation of the average rate of specific machine investment costs subject to farm size in the different branches of crop production

In respect of investment costs it is obvious that the increase of the number of own machines parallel with the increasing farm sizes effects the decreasing tendency of specific machine investment costs subject to farm size and local investment cost maximums arise on individual intervals. All this is by small farm sizes conspicuous. In the case of the three branches of crop production surveyed this phenomenon can be observed by different farm size each. In the case of field crop production the change from the power machine used in small-scale farming to the higher performance tractor and the connecting working machines due to the increasing property size is reasonable by about 30 ha. The purchase of the pulled harvesting machine with several special functions leading to a substantial rise of specific investment costs is also due at a size of 30 ha in field vegetable growing. In case of plantation cultivation, however, the change of category and the purchase of the low capacity pulled harvesting machine can already take place at a property size of 20 ha due to the remarkable shift-hour performance

which intensely effects the investment costs in this case as well. (Figure 6)

With the characterization of machine utilization and investment costs subject to farm size and with the phenomenon of activating the individual power machine categories we have dealt with in detail in our earlier essays (Magó 2008a). [9]

It can be stated here as well that one who intends to operate an own machine stock under the above mentioned size limits has to face a specific investment cost five to ten times higher than the acceptable cost level. If, however, one is forced to do that due to some production-technological pressure one has to try to decrease the specific costs of machine utilization by increasing machine utilization in order to keep the costs at an acceptable level.

#### Conclusion

It can well be demonstrated by the presented examples of the branches of crop production that while the investment of an own machine is not economical by small-scale production including the least machine labour per hectare demanding grains and oilseeds due to the low level of machine utilization already under 18 ha, the farm size limit of non-economical machine utilization is lower in case of field vegetable growing and plantation cultivation where the specific labour demand per unit of area is higher and the level of machine costs is already from 6-10 ha farm size on acceptable due to the better machine utilization.

Furthermore, the capacity of the machines assigned to the plant growing technologies applied in the latter branch is lower, their purchase price is mainly lower and this effects the machine cost level of small-scale farming in a more favourable way than the phenomena experienced in field crop production.

The aim of our research work and the exposition of its results are the professional support of the machine investment decisions and the machine utilization practice of the different size farms promoting hereby the creation of the conditions of fruitful farming and rational machine investment decisions.

In the present study we have tried to offer a general guideline considering a general crop plan and production technology characteristic of several branches with an overview of the composition of machine stock from the use of the lowest cost level to the highest technical level machinery, the machine demand and the utilization level of those together with investment and utilization costs which may serve as a basis and may open further research perspectives for the reduction of machine utilization costs both for the producers and for the professional organizations.

On the basis of the experiences of farm surveys it can be stated that the power and working machines appearing in small and medium size farms as new investments are adapted to the presented cost efficient machine system modelled subject to farm size (Magó 2008c). [11]

The work of small-scale producers is mainly supported by a power machine of 20-40-60 kW performance depending on branch, while several parameters of the power machine stocks of the medium and large-scale farms are equal to that of the machine system modelled in the calculations. The eventual deviations are due to the local production-technological demands resp. the performance demands of the working machines applied.

Practically the renewal of the machine stock of a given farming unit happens gradually, consequently it seldom occurs that the whole machine stock consists of brand new power machines as supposed in our model calculation. There are, therefore, especially in bigger size farms from time to time some less modern power machines representing an additional performance category, resp. an unreasonable number of dated light-universal auxiliary tractors to be found.

## Acknowledgement

The author would like to express his gratitude to the OTKA Fund for the financial support (F 60210).

## References

- [1] Baranyai Zs. - Sípos N. - Takács I.: (2008) Examination of Main Factors of Producers' Willingness to Cooperate in Hungarian Agriculture, Cereal Research Communications, Akadémiai Kiadó, Vol. 36: p. 723-726.
- [2] Fenyvesi L. - Gockler L. - Hajdú J. - Husty I.: (2003) A mezőgazdaság műszaki fejlesztésének lehetséges megoldásai. Gazdálkodás, No. 5. 1-15 p.
- [3] Gockler L.: (2007) The Purchase Price and Running Costs of Agricultural Machines in 2007, Mezőgazdasági Gépjárműüzemeltetés 2007. No.1., Hungarian Institute of Agricultural Engineering, Gödöllő.
- [4] Hajdú J. - Gockler L.: (2005) Relationship between Farm Size and Mechanisation. Hungarian Agricultural Engineering, Periodical of the Committee of Agricultural Engineering of the Hungarian Academy of Sciences, Vol. 18/2005. p. 50-54.
- [5] Hajdú J. - Magó L.: (2004) Characterization of the Mechanization of the Agriculture Following the Years of the Economical Change on the Basis of Hungarian Experiences, Proceedings of the 32<sup>nd</sup> International Symposium "Actual Tasks on Agricultural Engineering", Opatija, Croatia, 23-27. February 2004. Proc. p. 175-182.
- [6] Husty I.: (1999) A mezőgazdasági gépesítés ökonómiája és menedzsmentje. Mezőgazdasági Szaktudás Kiadó. Budapest. 266 p.
- [7] Magó L.: (2000) Relationship between Farm Machine Requirement and Farm Size, Gazdálkodás, Scientific Journal on Agricultural Economics – English special edition Vol. XLIV., No. 1., p. 66-75.
- [8] Magó L.: (2007) Models Showing Increase in Cost Efficiency of Mechanisation on Small and Medium Sized Arable Farms, Journal of Science Society of Power Machines, Tractors and Maintenance "Tractors and Power Machines", Novi Sad, Serbia. Vol. 12. No. 2., p. 54-61.
- [9] Magó L.: (2008a) Determination of Farm Size Limit of Reasonable Mechanisation by Modelling, Proceedings of the 36<sup>th</sup> International Symposium "Actual Tasks on Agricultural Engineering", Opatija, Croatia, 11-15. February 2008. Proc. p. 553-565.
- [10] Magó L.: (2008b) Low Cost Mechanisation for Efficient Land Use in Small and Medium Size Arable Farms, Cereal Research Communications, Akadémiai Kiadó, Vol. 36: p. 1111-1114.
- [11] Magó L.: (2008c) Efficient Machine Utilisation in Small and Medium Size Field Vegetable Production Farms", Journal of Agricultural Machinery Science, Agricultural Machinery Association - Ege University, Bornova-Izmir, Turkey, 2008. Vol. 4., No. 1., p. 81-85.
- [12] Magó L.: (2008d) Connection between Machine Utilisation and Operation Costs on Different Farms, in Edit.: Takács I. „Measuring Economic Efficiency of Technical Development Subsidies” Szent István University, Szent István Egyetemi Kiadó, Gödöllő, p. 213-228.
- [13] Nikolic R. - Savin L., et al.: (2007) Mechanisation and Estate Size, Journal of Science Society of Power Machines, Tractors and Maintenance "Tractors and Power Machines", Novi Sad, Serbia. Vol. 12. No. 1., p. 5-10.
- [14] Savin L.: (2004) Optimizacija sastava mašinskog parka u poljoprivredi, Disertacija, Poljoprivredni fakultet, Novi Sad, p. 209.
- [15] Takácsné György K. - Takács I.: (2003) Az üzemméret és tökehatékonyság összefüggései, a hatékonyságnövelés néhány alternatívája. In Birtokviszonyok és a méretgazdaságosság. A magyar mezőgazdaság nemzetközi versenyképessége NKFP-2003/4/32. Edit.: Szűcs I. Agroinform Kiadó. Budapest.. 99-169. pp.

# CHARACTERISTICS OF MACHINE UTILIZATION OF PLANT PRODUCTION FARMS IN HUNGARY

Zsolt BARANYAI - István TAKÁCS  
Szent István University, Faculty of Economics and Social Sciences, Gödöllő

## Introduction

In the Hungarian agriculture, the rather diversified estate system which was formed after the social transition has not always been paired with efficient power engine and machine system in economic and technical sense. [Magó, 2000; Husti, 1995] This increased the costs of machine use significantly. At the same time, in the fierce competition on the market of agricultural products, the efficiency of production is more and more valuable, which requires the rational decrease of the volume of expenses. [Varga, 2006]

Significant part of expenditures of agricultural production on arable land comes from the costs of machine operation, therefore – considering the current situation – it can be an area where we have some considerable reserves to increase efficiency. [Gockler, 2007]

For the above reasons the present research on primary database examines the changes and parameters of equipment supply of farms, and, the costs of machine use.

## Materials and methods

In order to examine the characteristics of machine use of Hungarian private farms we made a questionnaire survey complemented with deep interviews in the South Eastern part of Hungary, in the Southern Great Plain region, Békés county. The element number of the examined sample (N) is 111 private farms, which means 0,25% representativeness in Békés county and 0.02% representativeness nationally among private farms. As regards production lines, the county-level representativeness was 1.08%, and 0.04% at national level. On average 91.9% (s=16%) of farm-level Standard Gross Margin (SGM) of the surveyed farms comes from field crop production thus they can be regarded Specialist field crops (Fieldcrops) farms on the basis of the EU typology. Some typical data of the farms involved in the survey can be seen in Table 1.

The question groups completed together with the farmers included the following: general aspects of farms (form of farming, sphere of activities, size of own and leased land), natural indices of farming (production structure, results, machine supply, etc.) and also covered the areas connected with the co-operation willingness of farmers (frequency and method of co-operation, knowledge about the different institutionalized forms of co-operation, etc.)

Upon the research we have determined the economic size (ES) of each farm according to the EU methodology. It was made by the multiplication of branch sizes with branch SGM values – from FADN – according to the following relation:

$$ES = \left( \sum_{i=1}^n SGM_i \cdot s_i \right) \cdot u^{-1} \quad i = 1, 2, \dots, n \quad (1)$$

where  $ES$  = Economic size [ESU];  $SGM_i$  = Standard Gross Margin of branch  $i$  [EUR·unit<sup>-1</sup>];  $s_i$  = natural size of branch  $i$  [ha, pcs];  $u$  = 1200 EUR Standard Gross Margin;  $n$  = number of branches.

On the basis of the farm size determined by the above methodology, the private farms were grouped according to size categories: (1) 0 - <4 ESU; (2) 4 - <8 ESU; (3) 8 - <16 ESU; (4) 16 - <40 ESU; (5) 40 - <100 ESU; (6) ≥ 100 ESU. It should be noted that the above group limits correspond with those used in Farm Accountancy Data Network.

Table 1 General features of the examined sample (N=111)

Title	0-4 ESU	4,1-8 ESU	8,1-16 ESU	16,1-40 ESU	40,1-100 ESU	Over 100 ESU	Σ
Number of farms (pcs)	20	21	25	35	7	3	111
Average farm size (ESU)	2,3 (s= 1,04)	5,6 (s= 0,98)	12,4 (s= 2,26)	25,9 (s= 6,00)	56,9 (s= 16,9)	110,3 (S= 2,08)	19,0 (s= 21,3)
Proportion of field crop production from farm SGM (%)	88,5	90,0	88,9	95,5	83,4	75,2	88,6
Average farm size (ha)	6,4 (s= 2,92)	14,2 (s= 5,05)	26,4 (s= 10,3)	66,1 (s= 15,6)	154,1 (s= 53,8)	234,0 (s= 53,2)	45,2 (s= 51,0)

Source: own construction

The value of specific assets capital (EUR·ha<sup>-1</sup>) fixed in machines and equipment was used for expressing the equipment supply of farms. Great part of machines used by the farms is old, amortized down, therefore the consideration of their value on the basis of accounting principles is not possible and it would easily give misleading results. We applied the evaluation of farm equipment supply on market prices in order to solve the problem. The individual market values of machines were provided by commercial newspapers, internet portals and farmers. The determination of machine supply at farm level in a relation is as follows:

$$sFAC = \left( \sum_{j=1}^m p_j(a, P, r) \right) \cdot A^{-1} \quad j = 1, 2, \dots, m \quad (2)$$

where:  $sFAC$  = specific Fixed Assets Capital [EUR·ha<sup>-1</sup>];  $p_i$  = is the specific market value of machine, equipment number  $i$  [EUR] in relation to age ( $a$ ), performance category ( $P$ ) and relation ( $r$ );  $m$  = number of machines, equipment. (As regards methodology, it should be mentioned that the consideration of the actual technical state, as the third factor determining the specific value would also be justified but its parameterization is very complicated in each case. In our model we have made the simplifying assumption that the age of the machines also refers to the technical state!) The variable  $A$  in the relation expresses the total area of the given farm [ha].

The index expressing machine supply can be evaluated from two aspects: on the one hand it refers to the quantity supply, on the other hand it expresses the technological level. The index in itself does not imply which aspect is dominant in the given farm, in order to see this, further indices should be introduced and analysed (e.g.: Power machines density index (pcs·100 ha<sup>-1</sup>), Average engine output (kW·ha<sup>-1</sup>)).

In order to judge the level of mechanization of the given farm, the degree of self-supporting concerning mechanization, the index of „extraneous machine work need” was introduced. On the basis of technological needs implied by the production structure of the farms the index shows size of the labour value which should be obtained from external sources because cannot be ensured by the given farm based on its own technical resource base. The determination of labour value was made with leased service tariffs, on the basis of the following relation:

$$sNoEM = \left( \sum_{i=1}^n e_i(s, d) \cdot l_i \right) \cdot A^{-1} \quad i = 1, 2, \dots, n \quad (3)$$

where:  $sNoEM$  = specific Need of Extraneous Machinery [EUR·ha<sup>-1</sup>];  $e_i$  = quantity of work operation number  $i$  [unit], which can be determined in relation to the lack of means ( $d$ )

hampering the entire completion of sowing structure ( $s$ ) and the connected agrotechnical operations;  $l_i$  = lease service tariffs of work process unit number  $i$  according to the local practice [EUR·unit<sup>-1</sup>];  $A$  = the area used by the farm for agricultural purposes [ha];  $n$  = number of types of missing assets.

The capacity utilization of technical resources of farms was determined on the basis of figures by Takács-György [1994] and Gockler [2007]. The estimated global utilization value at farm level was calculated on the basis of works made within the farm. Normal hectare was applied as an exchange equivalent.

$$CU(\eta) = \frac{w_r(A, s)}{w_p(v, a, r, c)}$$

where:  $\eta$  = capacity utilisation [%];  $w_r$  = actually utilised capacity in the farm in relation to the area of the farm ( $A$ ) and the sowing structure ( $s$ );  $w_p$  = theoretically available capacity on the basis of the volume ( $v$ ), age ( $a$ ), relation ( $r$ ) and performance category ( $c$ ) of machine and assets supply.

The following relation was used for expressing the total specific machine costs of private farms:

$$sTC = sVC(a, P, r, s) + \frac{FC(a, P, r)}{A} + sNoEM(s, d, l)$$

where:  $sTC$  = specific total costs of machine works [EUR·ha<sup>-1</sup>];  $sVC(a, P, r, s)$  = specific variable costs of machine work (in relation to age ( $a$ ), performance category ( $P$ ), relation ( $r$ ) and crop structure ( $s$ ) [EUR·ha<sup>-1</sup>];  $FC(a, P, r, s)$  = total fixed costs (in relation to age ( $a$ ), performance category ( $P$ ) and relation ( $r$ ) [EUR];  $A$  = total area used by the farm for agricultural purposes [ha];  $sNoEM$  = cost of specific extraneous machine work (in relation to crop structure ( $s$ ), assets shortage ( $d$ ) and lease service tariffs ( $l$ )).

Prioritized area of the research was the mapping of co-operation willingness among farmers in the utilization of technical resources (basically the lending of machines, equipment, and the mutual assistance of each other in the form of labour with machines). In order to express this, the respondents evaluated their co-operation willingness in a scale from 1 to 4.

1 – does not intend to co-operate with anybody either at present or in the future (completely reserved); 2 – co-operation occurs rarely, occasionally, does not plan to change this in the future; 3 – co-operates with fellow farmers with medium frequency, is not totally reserved from making these relations closer; 4 – often co-operates and plans to go on with this attitude in the future (completely open).

Statistical examinations were made with univariable methods (average, dispersion calculation) and with boxplot analysis based on them.

## Results

During our work, first we determined the main assets supply parameters in the economic size unit categories, on the basis of the above outlined methodology (Table 2). The experiences show that the surveyed farms can be regarded independent from the aspect of machine supply from medium-large ((16,1-40 ESU), basically some valuable target machine (e.g. harvester) is missing from their machine pool. The relative machine supply indices are higher in the smaller farms, but in spite of this, the need of extraneous machine work is high, which refers to the lack of assets required for the realization of some agrotechnical elements.

To be more established methodologically, the boxplot analysis carried out supports our statement concerning machine supply by delimiting two, significantly different clusters (Figure 1., a.). As regards co-operation willingness of farmers, the reduction of co-operation aptitude can be observed by increasing of size unit

in its tendency (Figure 1.a.) It should also be noted that the co-operation activities are the lowest in the smallest size categories, which can be explained with the low economic interests. Another important aspect is that the frequency and depth of co-operation is very low even in those clusters which confess to be co-operative.

**Table 2** Some important assets supply indices of the examined private farms

Descriptors	0-4 ESU	4,1-8 ESU	8,1-16 ESU	16,1-40 ESU	40,1-100 ESU	Over 100 ESU	$\Sigma$
sFAC (EUR·ha <sup>-1</sup> )	468 (s=672)	624 (s=616)	436 (s=916)	828 (s=596)	756 (s=584)	368 (s=120)	676 (s=684)
sNoEM (EUR·ha <sup>-1</sup> )	202,8 (s=76,0)	154,4 (s=66,5)	124,4 (s=73,2)	47,2 (s=40,8)	29,2 (s=30,4)	19,2 (s=26,8)	60,4 (s=336,8)
Average power machines* capacity (kW)	34,7	54,5	54,7	73,0	83,5	74,0	67,2
Average age of power machines (years)	29,1 (s=9,0)	14,7 (s=6,5)	16,2 (s=8,6)	13,3 (s=6,5)	9,8 (s=4,3)	13,1 (s=3,4)	14,5 (s=8,9)
Average engine output (kW·ha <sup>-1</sup> )	3,52 (s=5,16)	3,65 (s=3,43)	2,31 (s=3,13)	2,78 (s=1,79)	2,26 (s=2,29)	1,79 (s=0,83)	2,55 (s=3,30)
Estimated utilisation of capacity (%)	47	45	72	59	73	93	65

Source: own calculation

\* power machines are: tractors, harvester machines, lorries, mechanical loaders, self propelling sprayers

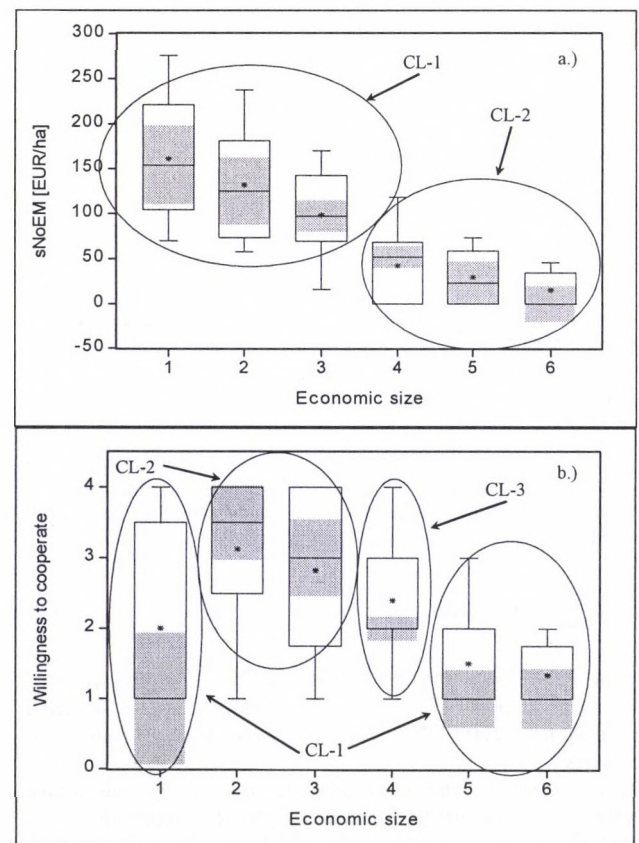

Source: own calculation

**Figure 1** Boxplot analysis of extraneous machine work need and co-operation willingness in relation to economic size unit

On the basis of the assets supply parameters and utilising the relation described in the methodology, the costs of private farms connected to machine use were modelled (Figure 2). The model calculations presented the gradual changes of costs connected to machine use in relation to size unit.

### Conclusions

The machine and assets supply of farms is very different in the economic size unit groups which indicates the presence of resource-allocation problems. The costs of structural problems appearing in the significant assets deficiencies of smaller farms and in assets surplus of mainly medium and larger farms are very considerable in both relations and causes significant competitive disadvantages in the branch. In our opinion, adequate reply to the existing problems can be given by concentration, at farm level or „virtually” through the co-operation of farmers (e.g. machine rings). Although the reality of this latter solution seems to be uncertain in our days, but in

the future it is absolutely necessary to enforce changes in the disputed area.

### References

- [1] Gockler Lajos (2007): A mezőgazdasági gépek ára és üzemeltetési költsége 2007-ben. FVM MGI Gödöllő, 2007. január.
- [2] Husti István (1995): A termelőberendezések kihasználásának gazdasági konzekvenciáiról. Akadémiai Kiadó. Budapest.
- [3] Magó László (2000) „Relationship between Farm Machine Requirement and Farm Size”, *Gazdálkodás, Scientific Journal on Agricultural Economics – English special edition Vol. XLIV., No. 1., p. 66-75.*
- [4] Takácsné György Katalin (1994): A családi gazdálkodás méretére ható tényezők modellvizsgálata I., II. *Gazdálkodás*, 1994. 38.4. 65-69 pp.; 35.5 54-60 pp.
- [5] Varga Tibor (2006): Ráfordítások és hozamok az EU-ban és Magyarországon. *Gazdálkodás*. 50. 4. 7-17 pp.

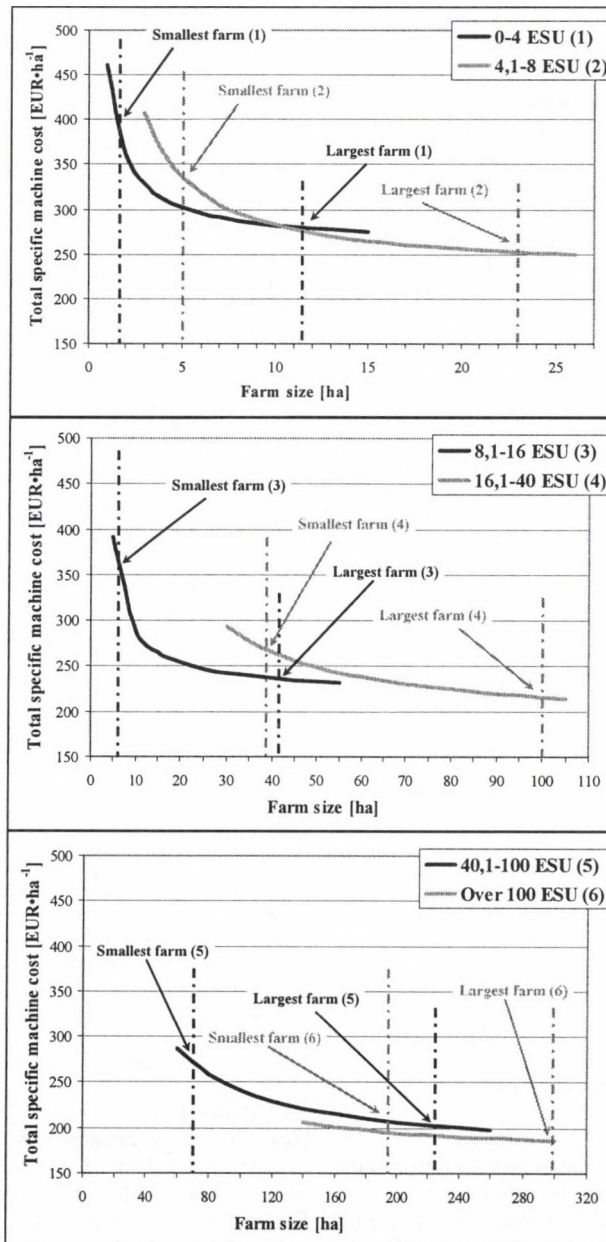

Figure 2 The specific total costs of machine operation according to size unit categories in the examined private farms.

# USAGE SIMPLEX METHOD TO DETERMINE REQUIRED NUMBER OF TRACTOR SYSTEMS FOR PLOUGHING

Lazar SAVIN - Ratko NIKOLIĆ - Timofej FURMAN - Milan TOMIĆ - Mirko SIMIKIĆ  
Faculty of Agriculture, University of Novi Sad, Serbia

## Introduction

Application of grapho-analytic method yields a machinery pool structure which does not satisfy the optimal economic criteria, thus requiring the use of linear programming, **Nikolic** (1984). The method of linear programming, i.e. the simplex method, satisfies the economic criterion of planning structure and capacity of machinery pool, **Magó** (2002; 2007). This criterion is the minimization of tractor operation costs under the given production and technical conditions, **Novkovic** (1990), since purchase of heavy tractors is based on the ploughing operation with largest operation costs within the production technology used. Using the method of linear programming, an optimization was made for the required number of tractors for ploughing. Ploughing requires tractors from 100 to 300 HP and within these boundaries 4 tractor categories exist; namely: 30, 40, 50 and 60 kN. The requirement of optimization was that the optimal number of tractors in each category allows ploughing at minimal variable costs of operation, that is, to minimize the objective function within the given constraints. This is the way to enhance the economic effects of the overall production technology, **Savin** (2004). It is also supposed that the analysis of influence of plot length, specific soil resistance and size of estate, will allow selection of ploughing tractor between the four categories.

## Material and methods

Soil conditions are defined by specific ploughing resistance, ranging from 0.5 to 1.5 daN/cm<sup>2</sup>, and by the matching resistance of tractor aggregates.

Seeding structure comprises 11 crops: mercantile wheat, winter barley, spring barley, oilseed rape, soybean, sunflower, mercantile corn, seed corn, silage corn, sugar beet and new alfalfa. The plot length was varied from 400 to 1600 m.

The size of estate was chosen to match bigger producers, the acreage ranging from 1000 to 6000 ha of arable soil.

Numerical model was formed assuming that a new machinery pool is designed and the results will be used for acquisition of the required category tractors.

Linear programming model should have a constraint matrix (containing technical coefficients and a vector representing resource constraints) and an objective function, that is, a function of optimal criteria.

The variables are the number of work hours of the tractors of the designated category:

$$X_{ij} \geq 0$$

$X_{ij}$  (h) - number of work hours for the i-th tractor category,

when ploughing the j-th crop

where:

m - is the number of available tractor categories

n - is the number of crops

The function of optimal criterion is a mathematical formulation of the optimal criterion, which will be used to select the required tractor category. In this case, the ploughing should be completed for all crops within the set agrotechnical period, at minimal variable costs.

$$\sum_{i=1}^m \sum_{j=1}^n C_{ij} X_{ij} = V_u \Rightarrow \text{Min}$$

where:

$C_{ij}$  (din/h) - is a coefficient of the objective function, representing variable costs for using the tractor of the i-th category to plough the j-th crop.

$V_u$  (din) - are the total minimal variable costs for all tractor categories.

Within the formed mathematical model there is only one constraint, since a new machinery park is to be designed. Total quantity of particular crops ( $B_j$ ) must be entirely cultivated using the selected tractor categories. Technical coefficients in the left-hand side constraints are work efficiencies, while the resources are total acreage for each crops. They are defined as:

$$\sum_{i=1}^m b_{ij} X_{ij} \geq B_j$$

where:

$b_{ij}$  (ha/h) - work efficiency of the i-th tractor category when ploughing the j-th crop

$B_j$  (ha) - total acreage under the j-th crop

Period from Sept. 20, to Nov. 20, was adopted for working period, because it is the busiest time for field works.

In order to appreciate the influence of specific soil resistance on the structure of the machinery pool which is used to assemble the tractor system for ploughing, a special mathematical model was made and implemented in Visual Basic. Simulation was run using this program, which resulted in maximal work efficiencies for each particular specific soil resistance. The mathematical model was programmed in Solver - Ms Excel's sub-program, while the results were verified by Lindo - software application specialized in linear optimization. Computation of work efficiency was performed by the Visual Basic program which simulated the effect of specific soil resistance on the shift efficiency for each tractor category.

## Results of investigation

For a 2000 ha estate size, specific soil resistance of 0.8 daN/cm<sup>2</sup> and plot length of 800 m, the required number of the 40 kN category tractors was established. The optimal solution is listed in **Table 1**.

Table 1 Structure of optimal solution

No.	Independent variables	Value (hours)
1.	$X_{2,1}$	453.16
2.	$X_{2,2}$	55.50
3.	$X_{2,3}$	22.20
4.	$X_{2,4}$	400.60
5.	$X_{2,5}$	499.16
6.	$X_{2,6}$	289.95
7.	$X_{2,7}$	26.90
8.	$X_{2,8}$	16.82
9.	$X_{2,9}$	47.54
10.	$X_{2,10}$	67.27
11.	$X_{2,11}$	7.83
$V_{u\text{min}}$		30,817.8 EUR

By summing up the required number of work hours for particular tractor categories, and by dividing that number by the available work hours for the critical period, one computes the required number of tractors for each category (Tab. 2).

For the given working conditions, only one tractor category satisfied optimal solution, namely, the 40kN category, while the rest of the 30, 50 and 60 kN categories failed to satisfy the solution. The required number of tractors decreases with the increase of plot length, **Fig.1, Tab.3**. Adopting the required number of

tractors at 400m plot length as the base value, one derives a series of base indices with identical values. Plot length does not impact the selection of tractor category, since the same category is valid for all plot lengths.

**Table 2** Required number of tractors computed by linear programming

No.	Tractor category (kN)	Utilization (h)	Required number of tractors (units)
1.	30	0	0
2.	40	1881.97	2.789
3.	50	0	0
4.	60	0	0

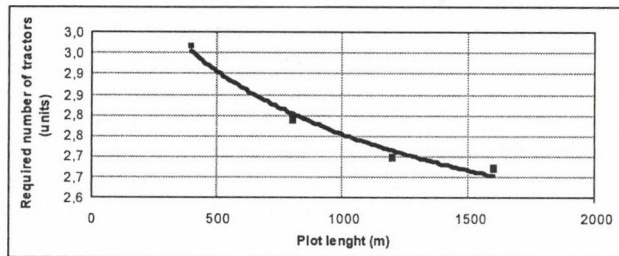
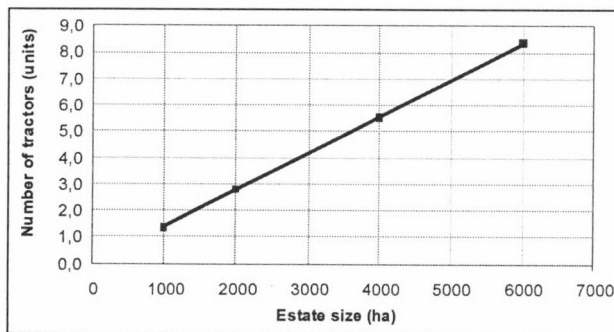

**Figure 1** Relation between plot length and the required number of tractors of the 40 kN category,  $k_s=0.8 \text{ daN/cm}^2$ ,  $A=2000 \text{ ha}$

**Table 3** Relation between the required number of tractors and plot length, with base indices  $k_s=0.8 \text{ daN/cm}^2$ ,  $A=2000 \text{ ha}$

No	Tractor category (kN)	Required number of tractors at various plot lengths (m)				Indexes			
		400	800	1200	1600	400	800	1200	1600
1.	30	0	0	0	0	0	0	0	0
2.	40	2.967	2.789	2.699	2.672	100	94.00	90.97	90.06
3.	50	0	0	0.000	0.000	100	0	0	0
4.	60	0	0	0	0	100	0	0	0
Total minimal costs (EUR)		32,784.1	30,817.8	30,175.7	29,531.0				

The increase of estate size causes the number of tractors required for ploughing to increase proportionally, Fig.2, Tab.4. Adopting the required number of tractors at 1000 ha estate size as the base value, one derives a series of base indices with the following values: 200.60; 401.20 and 602.41. Variations in estate size do not affect the change in the number of required tractor categories which already satisfy the solution, but only the number of tractors.



**Figure 2** Relation between estate size and the required number of tractors of the 40 kN category,  $k_s=0.8 \text{ daN/cm}^2$ ,  $L=800 \text{ ha}$

Variations in specific soil resistance not only affect the required number of tractors, but also change the tractor categories which satisfy optimal solution, Tab.5, Fig.3. By all specific soil resistances, two or three tractor categories satisfied the optimal solution, the only exception being the soil resistance of 1.1  $\text{daN/cm}^2$ , where only the 40 kN category satisfied. Lower specific soil resistances require lighter tractor categories, while

higher specific soil resistances require heavier tractor categories. The differences between computed optimal solutions show that, of all considered factors of influence, specific soil resistance has the greatest impact on the required number of tractors.

**Table 4** Relation between the required number of tractors and estate size, with base indices  $k_s=0.8 \text{ daN/cm}^2$ ,  $L=800 \text{ m}$

No	Tractor category (kN)	Required number of tractors at various estate sizes				Base indexes			
		1000	2000	4000	6000	1000	2000	4000	6000
1.	30	0	0	0	0	0	0	0	0
2.	40	1.395	2.789	5.578	8.367	100	200	400	600
3.	50	0	0	0	0	100	0	0	0
4.	60	0	0	0	0	100	0	0	0
Total minimal costs (EUR)		15,408.9	30,817.8	61,635.6	92,453.5				

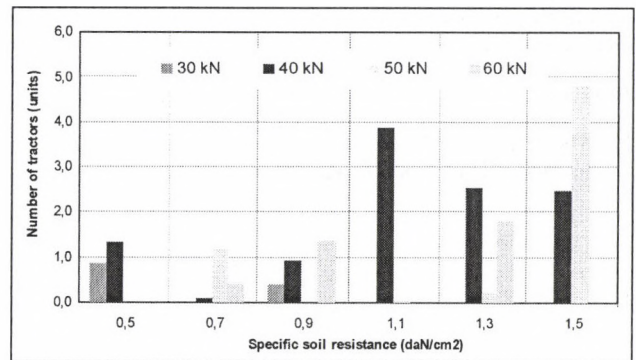

**Figure 3** Relation between the required number of tractors of various categories and specific soil resistance,  $A=2000 \text{ ha}$ ,  $L=800 \text{ m}$

**Table 5** Relation between the required number of tractors and specific soil resistance,  $A=2000 \text{ ha}$ ,  $L=800 \text{ m}$

No.	Tractor category (kN)	Required number of tractors at various specific soil resistance ( $\text{daN/cm}^2$ )					
		0.5	0.7	0.9	1.1	1.3	1.5
1.	30	0.860	0.000	0.386	0.000	0.000	0.000
2.	40	1.326	0.082	0.918	3.855	2.506	2.466
3.	50	0.000	1.149	0.918	0.050	0.218	4.768
4.	60	0.000	0.397	1.345	0.010	1.772	0.000
Total minimal costs (din)		21,033.0	27,049.6	39,766.8	43,597.8	66,429.6	102,929.6

With regard to the chosen algorithm used to form the vector systems, it is obvious that technical/technological features of tractors influence the required number of tractors. Most influential among them are the number and the sequence of gear shifts within the 4-12 km/h operating speed range, which covers about 90% of technological operations. The applied algorithm of linear programming allows, within the same tractor category, the selection of tractor with superior haulage power. This lowers not only costs of exploitation, but also production costs, which goes in favour of the initial working hypothesis.

### Conclusion

Based on the analysis performed, following conclusion can be drawn:

- For the defined working conditions, out of available 30, 40, 50 and 60 kN categories, the optimal criterion was satisfied by the 40 kN category tractor. The required number of the 40 kN category tractors is 2.789 units.
- The required number of tractors decreases with the increase of plot length, but plot length has no impact on the selection of tractor category, since the same category is valid for all plot lengths.
- The increase of estate size causes the number of tractors required for ploughing to increase proportionally. However, this increase has no impact on the choice of the optimal category, but influences only the number of required tractors.

- Variations in specific soil resistance not only affect the required number of tractors, but also change the tractor categories which satisfy optimal solution. By all specific soil resistances, two or three tractor categories satisfied the optimal solution, the only exception being the soil resistance of 1.1 daN/cm<sup>2</sup>, where only the 40 kN category satisfied the optimal criterion.
- Lower specific soil resistances demand lighter tractor categories, while higher specific soil resistances demand heavier tractor categories. The differences between computed optimal solutions show that, of all considered factors of influence, specific soil resistance has the greatest impact on the required number of tractors.
- Application of the algorithm for ploughing tractor system design, employs linear programming method to define not only the required number of tractors, but also to select one or more tractors within the same category, which have superior haulage power.

#### References

- [1] **Magó L.:** (2002) Selection of the Machinery Fleet by Integer Non-linear Programming, Innovation in the Agriculture and the Industry, AgEng2002 - International Conference on Agricultural Engineering. Abstracts. Budapest 30. June -4. July 2002. Vol. 2. p. 112-113.
- [2] **Magó L.:** (2007) Models showing increase in cost efficiency of mechanisation on small and medium sized arable farms, Journal of Science Society of Power Machines, Tractors and Maintenance "Tractors and Power Machines", Novi Sad, Serbia. Vol. 12. No. 2., p. 54-61.
- [3] **Nikolić, R.:** (1984) Optimizacija parametara poljoprivrednih traktora u cilju određivanja racionalnog sastva mašinskog parka, Doktorska disertacija, Poljoprivredni fakultet, Novi Sad, p.230.
- [4] **Novković, N.:** (1990) Optimiranje poljoprivredne proizvodnje na bazi više kriterijuma optimalnosti, Disertacija, Poljoprivredni fakultet, Novi Sad, p. 97
- [5] **Radojević, R.:** (1998) Optimizacija strukture traktorsko-mašinskog parka i racionalizacija vremena rada u ratarskoj proizvodnji, Doktorska disertacija, Zemun, p. 162.
- [6] **Savin, L.:** (2004) Optimizacija sastava mašinskog parka u poljoprivredi, Disertacija, Poljoprivredni fakultet, Novi Sad, p. 209.

## CLOSING FORCE MEASUREMENT ON CRIMPED CLOSURES

Zsolt MAGYARY-KOSSA<sup>1</sup> - János BENKŐ<sup>2</sup> - Gyula VINCZE<sup>2</sup>

<sup>1</sup>Sure TORQUE Európa Kft., Budapest

<sup>2</sup>Szent István University, Gödöllő

### Introduction

Crimped closure is primarily used for airtight closing of pharmaceutical and cosmetic industry products packaged in bottles (e.g. ampoules). Airtight closure is provided by the rubber seal placed in the filled bottle, which is usually tightened to the opening of the bottle by an easily deformable aluminium plate. A special tool, a so-called crimping head is used for crimping. The tool compresses the rubber plug and bends the aluminium lid on the lower brim of the bottle mouth. Airtight closure is provided by the compression stress remaining in the rubber plug.

### Fundamental theory

Based on those written in the introduction, the sealing is formed between the bottle and the polymer surfaces, therefore let us introduce the main characteristics of these two materials and that of their getting into contact.

The framework of polymers is made up of carbon atoms. These are not arranged in a straight line within the polymer chain. The connecting lines between the atoms give a valence angle of 109.5°. The different elements of the chain may swing by keeping up the value of the valence angle. Due to those mentioned above, polymer chains are rather flexible and in most cases are shaped like a clew. Decrease in temperature causes expansion of the chain, and vice versa. This is because heat-removal decreases the entropy of the polymer chain, and decreased entropy is coupled with a more arranged state, which in our case is the expanded condition. This means that by decrease in temperature the elastic closing element would expand, if it was not blocked by the closing brim. However, due to the blocking a higher force is developed in it. Glass is an *n*-type semi-conductor, which means that a low number of free electrons can always be seen in it, which can couple with the oxygen atom colliding with the surface. This way, an oxygen layer with a molecular thickness may develop on its surface. However, the potential barrier between the two surfaces is thin. It is known that electrons can penetrate through a thin potential barrier with the tunnel effect. Therefore, it is possible that oxygen atoms within the crystalline region of the polymer may bind the free electrons of the glass, due to their being electronegative. In this case an application of force develops between the ions of the polymer and the ions of the glass, due to which the two materials create a strong molecular bond along the contact surface.

If force is applied parallel to the contact surface, the ions within the layer move related to each other. In case the maximum shear stress occurring due to symmetry causes is exceeded, the surfaces slide on each other. In this case sliding friction is created. More specifically, the above mentioned concern a local contact surface. The values of  $\tau_{\max}$  at the different local contact surfaces may differ according to the degree and extension of the local order. The condition of sliding is that the shear stress values generated at the local contact surfaces should exceed the value of the local  $\tau_{\max}$  everywhere.

So, the condition of shear cut of the surfaces is:

$$\sum_i \tau_{\max i} \Delta A_i = F_{ny} \quad (1)$$

where  $F_{ny}$  is the force applied on shearing,  $\Delta A_i$  is the  $i^{\text{th}}$  local contact surface size, and  $\tau_{\max i}$  is the shear resistance on this surface. The average shear resistance can be defined from this:

$$\tau = \frac{F_{ny}}{A_{\text{val}}} = \sum_i \tau_{\max i} \frac{\Delta A_i}{A_{\text{val}}} \quad (2)$$

where  $A_{\text{val}}$  is the size of the actual contact surface.

Based on the above physical formula it can be stated, that there is an average maximum shear stress, where sliding starts. This apparently corresponds to the shear stress introduced by metallic materials. Let's find out how the size of the actual surface can be defined. The polymer is an elastic material, in our case no plastic deformation is to be taken into calculation. So the actual contact surface is created due to plastic deformation, not in the way as by metallic materials. It is also apparent that it is enough to take the deformation of the polymer into consideration, as the elastic modulus of the glass is much greater. Since the actual contact surface is created as the resultant of deformations of small peaks, it is assumable that the ratio of the normal force compressing the surfaces and the actual contact surfaces can be given by a function  $f(E, G)$  made up of the elasticity ( $E$ ) and shearing ( $G$ ) modulus of the polymer:

$$A_{\text{val}} = \frac{F_N}{f(E, G)} \quad (3)$$

Substituting this into formula (2), the shearing component of the friction force is given as

$$F_{\text{nyir}} = \tau A_{\text{val}} = \tau \frac{F_N}{f(E, G)} \quad (4)$$

The force generated during the sliding of the surfaces on each other is the resultant of this and the cohesion force:

$$F_s = F_{\text{nyir}} + F_{\text{koh}} = \frac{\tau}{f(E, G)} F_N + F_{\text{koh}} \quad (5)$$

shaped, where  $F_{\text{koh}}$  is the cohesion force.

In case  $F_{\text{koh}}$  is negligible by the shear force, the well-known formula

$$F_s = \frac{\tau}{f(E, G)} F_N = \mu F_N \quad (6)$$

is the result for the friction force.

### Applying theory on the assessment of the degree of tightness

Tightness is total, if the sizes of the above introduced two surfaces are identical, that is, if

$$A_{\text{val}} = A \quad (7)$$

It is evident that this state cannot be reached in practice, since extraordinary normal force is necessary for this. Therefore, there is such a surface ratio

$$\eta = \frac{A_{\text{val}}}{A} \quad (8)$$

which corresponds to practical requirements. The question is, whether this can be related to friction force. We will show that it can. The actual surface from (8) is actually:

$$A_{val} = \eta A \quad (9)$$

From another point of view, the same from (3):

$$A_{val} = \frac{F_N}{f(E, G)} \quad (10)$$

Normal force can be expressed from (6) this way:

$$A_{val} = \frac{F_N}{f(E, G)} = \frac{F_s}{\mu f(E, G)} = \frac{F_s}{\tau} \propto F_s \quad (11)$$

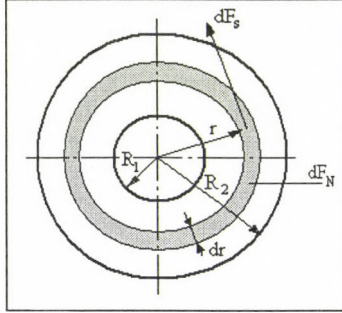

Figure 1 Relationship between the actual surface and the torque

So the measurement of the size of the actual surface can be reduced to the measurement of the friction force. The question is, whether this statement is true on the torque necessary for turning the closure element, since no friction force, but torque is measured. It will be shown that it is.

From the aspect of the generation of friction force and torque it is assumable that the polymer plug and the glass bottle get in contact along a circular ring (Figure 1).  $dF_N$  normal compressing force is applied on the  $dr$ -thick circular ring-shaped contact surface. This force according to (4) generates

$$dF_s = \mu dF_N \quad (12)$$

friction force and

$$dM = \mu dF_N r \quad (13)$$

torque. The resultant torque generated on the sealing surface is:

$$M = \int dM = \int r \mu dF_N \quad (14)$$

Let the normal force compressing the surfaces be

$$f_N(r) = \frac{dF_N}{2\pi r dr} \quad (15)$$

its distribution function is known, then the resultant torque can be calculated using the relationship

$$M = \int dM = \int r \mu dF_N = \mu \int_{R_1}^{R_2} r 2\pi r f_N(r) dr \quad (16)$$

At the same time, according to (8) the actual contact surface is in relation with the normal force compressing the surfaces:

$$dA_{val} = \frac{dF_N}{f(E, G)} = \frac{1}{f(E, G)} 2\pi r f_N(r) dr \quad (17)$$

So even the actual surface can be calculated from the distribution function:

$$A_{val} = \int dA_{val} = \frac{dF_N}{f(E, G)} = \frac{1}{f(E, G)} \int_{R_1}^{R_2} 2\pi r f_N(r) dr \quad (18)$$

Applying the mean value theorem of integral calculus on (16), the result is as follows

$$M = \int dM = \int r \mu dF_N = \mu R^* \int_{R_1}^{R_2} 2\pi r f_N(r) dr \quad (19)$$

where  $R^*$  is the defined radius value within the interval  $(R_1, R_2)$ . Comparing relationships (18) and (19) the following relationship arises

$$\begin{aligned} M &= \int dM = \int r \mu dF_N = \mu R^* \int_{R_1}^{R_2} 2\pi r f_N(r) dr = \\ &= \mu R^* f(E, G) A_{val} = \tau R^* A_{val} \propto A_{val} \end{aligned} \quad (20)$$

which is the proof for our statement.

### Rheology and mechanical model of the closing process

Rheology in our case means that the material behaviour of the polymer plug (Figure 2) serving as a seal can be described as elastic and viscous behaviour. The resultant stress generated in the polymer plug is the sum of an elastic and a viscous stress:

$$\sigma = \sigma_{rugg} + \sigma_{visz} \quad (21)$$

The closing process is assessed according to the mechanical substitute picture shown on Figure 3. On the figure,  $m$  is the mass of the crimping head, on which the crimping force is applied through the spring characterized by spring constant  $D$ . Due to the crimping force the spring suffers deformation  $x_1$ , and the polymer plug substituted with Poyinting-Thomson-test suffers deformation  $x_2$ .

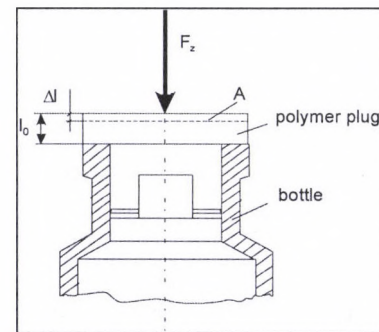

Figure 2 Simplified scheme of the polymer plug and the bottle

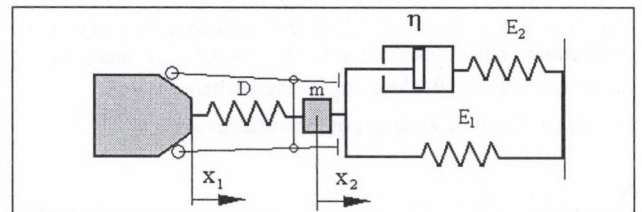

Figure 3 Mechanical model of the closing process

Applying *Newton's* 2nd axiom on the model, the differential equation

$$m \frac{d^2 x_2}{dt^2} = -D(x_2 - x_1) - \sigma A \quad (22)$$

is given, where  $\sigma$  is the stress generated in the polymer plug, which can be defined from the following equation expressing the relationship between the generated stress and extension.

$$\sigma + T_2 \frac{d\sigma}{dt} = E_1 \varepsilon + E_1 T_1 \frac{d\varepsilon}{dt}, \quad (23)$$

where the time constants are:

$$T_1 = \eta \frac{E_1 + E_2}{E_1 E_2}, \quad T_2 = \frac{\eta}{E_2}. \quad (24)$$

In this case the specific extension of the plug is given, which can be related to the displacement  $x_2$  shown in *Figure 5*:

$$\varepsilon = \frac{x_2}{l_0}. \quad (25)$$

Using relationships (23) and (25) the following differential equation is given

$$\frac{d^2 x_2}{dt^2} + \omega_0^2 x_2 + \sigma(x_2) \frac{A}{m} = \omega_0^2 x_1, \quad (26)$$

$$\sigma + T_2 \frac{d\sigma}{dt} = \frac{E_1}{l_0} x_2 + \frac{E_1 T_1}{l_0} \frac{dx_2}{dt}, \quad \omega_0 = \sqrt{\frac{D}{m}}$$

where the time function of displacement  $x_1$  is the known function given by the parameters of the machine. Assuming that while the machine reaches its greatest displacement, transient effects take place, then the steady displacement of the plug can be defined from the above equations:

$$x_2 = \frac{\omega_0^2}{\beta + \omega_0^2} x_1, \quad \text{where } \beta = \frac{AE_1}{ml_0}. \quad (27)$$

According to this, the steady force generated in the plug is:

$$F_1(\infty) = \frac{AE_1}{l_0} x_2 = \frac{AE_1}{l_0} \frac{\omega_0^2}{\beta + \omega_0^2} x_1. \quad (28)$$

Dynamical behaviour of the system of equations can be tested using the *Laplace* transformation method. Using this method, the *Laplace* transformed displacement of the plug is given as

$$x_2(s) = -\frac{\omega_0^2}{s^2 + \beta \frac{1+sT_1}{1+sT_2} + \omega_0^2} x_1(s), \quad \text{where } \beta = \frac{AE_1}{ml_0}. \quad (29)$$

## Instruments elaborated for the measurements

In order to certify the theory introduced in the former points, measuring instruments were elaborated. *Figure 4* shows the instruments used for measuring closing force and torque. Closing force is detected by the transmitter built in the measuring cell, and the measurement sign appears on the display of the force-meter (*Figure 4/a*).

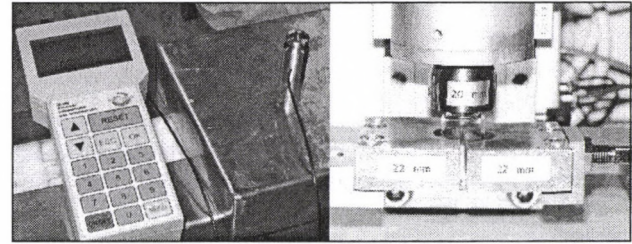

a/ closing force measuring instrument b/ sample holding for torque measurement

*Figure 4* Instruments measuring closing force and torque

*Figure 4/b* shows the instrument measuring the closing element torque of the samples crimped with the known closing force. The figure shows the control panel of the torque-meter and the instrument used for clamping the sample. Due to volume causes we do not give measurement results here, but it is to be noted that they support the theoretical concepts described in details.

## Literature

- [1] Benkő J. - Vincze Gy.: *Peremezett zárások elméleti alapjai. Kutatási jelentés. Gödöllő, 2006.*
- [2] Bodner, S. R. - Symonds, P. S.: Experimental and theoretical investigation of plastic deformation of cantilever beams subjected to impulse loading. *J. Appl. Mech.* 29. 1962. 719-728 p.
- [3] Bowden E. P. and Tabor D.: *Friction and Lubrication of Solids.* Oxford University Press, London 1950.
- [4] Hult, J.: *Creep in Engineering Structures.* Blaisdele Publishing Co. Waltham Massachusetts, Toronto, London, 1966.
- [5] Halász L. - Molnár I. - Mondvai I.: *A polimerek feldolgozásának reológiai alapjai.* Műszaki Könyvkiadó, Budapest, 1978.
- [6] Harper, W. R.: How do solid surface charged? *Static Electrification, Inst. Phys. Conf Ser.* 4. 3-11, 1967.
- [7] Kaliszky S.: *Képlékenységtan.* Akadémia Kiadó, Budapest, 1975.
- [8] Lin, T. H.: *Theory of Inelastic Structures.* J. Wiley & Sons, Inc. New York, London, Sydney, Toronto. 1968.
- [9] Nádai, A.: *Theory of Flow and Fracture of Solids.* Vol. 2. McGraw-Hill Book Co., New York, London, Toronto. 1963.
- [10] Odqvist, F. K. G.-Hult, J.: *Kriechfestingkeit metallischer Werkstoffe.* Springer Verlag, Berlin, 1962.
- [11] Sherwood R. S.: *The Mechanism of Dry Friction.* Engineering Report No. 6 of the Iowa Eng. Exp. Sta., Ames, Iowa 1951.
- [12] Wierzbicki, T.: Impulsive loading of rigid viscoplastic plates. *Int. J. Solid Structures* 3. 1967. 365-647 p.

# HUNGARIAN SUSTAINABLE ENERGY FINANCING FACILITY - MARKET ASSESSMENT FOR SUSTAINABLE ENERGY PROJECTS

Sándor MOLNÁR<sup>1</sup> - Márk MOLNÁR<sup>2</sup>

<sup>1</sup>Szent István University, Department of Informatics

<sup>2</sup>Szent Istvan University, Faculty of Economics and Business Management

## Introduction and Methodology

This study, commissioned by JASPERS, a workgroup of EIB and EBRD, is a quick scan of the sustainable energy market in Hungary. Its aims are to assess whether there is a basis for developing a Sustainable Energy Financing Facility (SEFF) to provide a credit line to domestic Hungarian banks to support investment into sustainable energy projects. The report examines the following aspects of the sustainable energy market:

- Current activities and state of play in the renewable energy and energy efficiency sectors
- Existing sources of finance
- Attitude of financial organizations and current levels of investment
- Current barriers to investment in the sector
- Possible application and suitability of the SEFF to incentivise investment.

The report is based on a brief analysis of publicly available data, data obtained through contacting Hungarian authorities and on interviews with financial organizations and project developers. In total 5 interviews were conducted within the financial sector, 30 ESCO's were contacted and 4 project developers were interviewed. In addition, every attempt was made to engage the responsible Hungarian authorities in our quest for suitable data, much of which was not publicly available. Care has been taken to ensure that the analysis and conclusions are supported by the data collected.

## Hungarian sustainable energy sector

This section looks at each of the aspects of the sustainable energy which SEFF is proposing to target: renewables, industrial energy efficiency and residential energy efficiency. It also outlines the state of play in Hungary's ESCO market. The sustainable energy sector makes up a small part of the energy sector in Hungary however, like many countries, parts of this sector are growing rapidly; particularly the renewables sector. In other areas, for instance the residential sector, the picture is less clear.

## Renewable Energy

Between 1992 and 2004 the supply of energy from renewable sources increased by 6.2% a year – albeit from a low base. Renewables are becoming an increasingly important part of primary energy sources in Hungary: in 2004 they contributed 3.6% to Total Primary Energy Supply (TPES), and in 2005 this increased to almost 4.3% (Energy Centre, 2007), hitting the government's 2010 target of generating 3.7% of electricity from renewable sources by 2010, 5 years early.

By far the largest source of renewable energy comes from biomass sources: biomass accounted for 3.5% of total electricity generated in 2003. Hungary has a large potential biomass resource: 5 million hectares of forest and 3 million hectares of farmland. However, the rapid growth of the biomass sector has led to concerns that all solid biofuel available in the country is now being utilized – the country went from using virtually no biomass to over 1 million dry tones in under 3 years. There have also been recent investments by coal-fired power stations to allow co-firing of biomass. This has further increased pressure on supply. Other renewables: wind, geothermal, solar and hydro do exist in Hungary but have not been able to command significant shares of the Hungarian market. For instance, there is considerable interest in wind generation but, due to fears over grid instability, the total amount of installed wind has been limited by the regulator to 330MW.

Table 1 above shows that there is significant potential in the renewables sector, supported by a high feed-in tariff. The relatively low payback times, coupled with additional technical grant aid and subsidy should allow easy access to domestic and international financial sources. It appears as though the renewables market will not be constrained by lack of suitable access to finance but, in the case of wind, by concerns over the grid and in the case of biomass, by a lack of resources. If the feed-in a tariff were to be reduced or stopped, payback times would double – it is unlikely that cheaper and easier access to finance would, by itself be able to overcome this barrier.

## Industrial Energy Efficiency

Data on the potential for energy efficiency in the small – medium sized industrial sector has been difficult to come by. It appears as though existing programmes to support this sector are already in operation and that improvements in energy efficiency coincide well with government policy to increase the competitiveness of domestic industry. Figure 2 shows that in many areas Hungarian industry is more energy intensive, than its European peers, with the metallurgic and non-metal processing industries showing the most potential for improvement.

Table 1 Realistic renewables potential and investment costs in power production to 2010

	2003 (GWh)	2005 (GWh)	2010 Total Generation Potential		2010 – Required Investment (billion HUF)	Payback Time (years)*
			MW	GWh		
Hydro Power	171	195	5	225.5	4.375	6.68
Wind Power	3.6	5.5	330	665.5	99	3.30
PV	0.06	0.06	0.16	0.4	0.18	23.6
Firewood, forestry waste, energy plants	109	1550	30	1730	24	5.17
Landfill waste biogas	20	2	-	2		
Waste water biogas	16.37	20	10	75		
Geothermal	-	-	5	32.5	4	6.11
Waste incineration	67	110	-	165		
<b>Totals</b>	<b>368.97</b>	<b>1882</b>	<b>380.16</b>	<b>2,892</b>		

Source: Ministry of Economic Affairs

\* Note this is a simple payback calculation and does not include a discount rate and other financing assumptions. Capacity factors are as follows: Hydro: 62%, Wind: 23%, PV: 23%, Firewood & waste: 68%, Geothermal: 74%. Costs are assumed as (000 HUF/kWh installed): Hydro: 875, Wind: 300, PV: 1125, Firewood & waste: 800, Geothermal: 800.

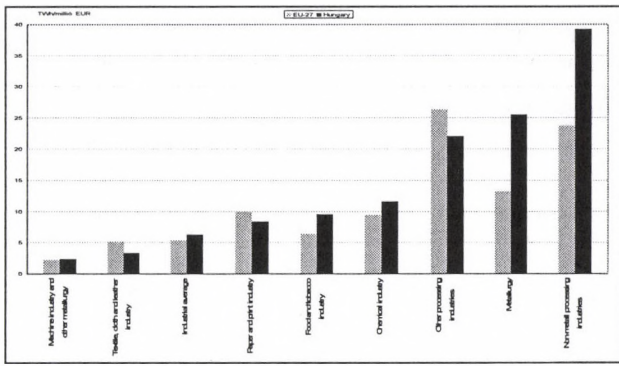
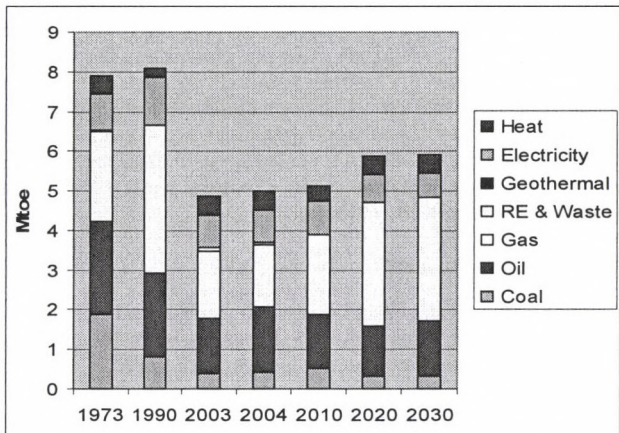

Figure 1 Energy intensity of Hungarian industry sub-sectors

Industrial energy consumption has declined by 35% from 8.1 Mtoe in 1990 to 5 Mtoe in 2004. The vast majority of this decrease can be attributed to the closure of many uncompetitive and inefficient factories which were operating under the former regime and the re-orientation to less energy intensive industrial processes.



Source: IEA, 2007

Figure 2 Historical and Future Energy Consumption in the industrial sector in Hungary

The forecast increase in energy consumption, and the reliance of industry on imported natural gas means there will be a natural demand for investment to improve energy efficiencies. Figure 4 shows that despite government subsidies, the price of gas, used by industry, has increased substantially since the year 2000.

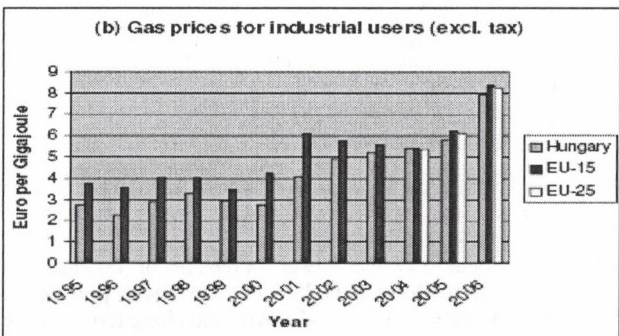

Source: Eurostat, 2007

Figure 3 Gas prices development in the EU ESCOs

As far as we are aware no official data exists on the size, and structure, of the Hungarian ESCO market. We estimate based on our existing knowledge of the market and conversations with

existing ESCOs that there are around 60-70 ESCOs operating in the Hungarian market<sup>1</sup>. These include the district heating company ESCOs, and several smaller companies. We estimate the number of significant market actors can be estimated in the range 10-12.

Hungarian ESCOs are typically involved in some energy production facility, CHP operation or district heating systems reconstructions. Activities include:

- Operation: boiler house operations, investments in energy savings financed by on-going savings being made, operation of climate systems, building and housing maintenance and operation, repair services;
- Investment activities: construction and housing mechanics installation, boiler house maintenance, energy efficient heating systems, industrial and hospital climate control system design and implementation.

ESCOs concentrate primarily on the industrial and municipality market. Indications suggest that growth in the domestic market slowing. Companies react to this by higher level of integration, and by looking for markets abroad<sup>2</sup>.

### Market activity and attitudes

#### Overview of Financial Institutions

A sample of six major financial institutions were interviewed by the project team in order to develop the lending community's perspective on current borrowing for renewable energy and energy efficiency projects, and the potential for lending to this market in the future. The results that follow are based on an attitudinal survey, conducted with individual representatives of some of Hungary's key financial institutions.

Basic information on the financial institutions' renewable energy and energy efficiency activities is summarised in the table below, based on the results of the attitude survey conducted.

#### Sustainable Energy Market Growth

In general, the perception amongst the respondents was that the existing sustainable energy market is attractive and that, providing certain conditions could be improved, uptake of finance for RES and EE is likely to increase. The trend is already on an upward curve.

Key comments in relation to the future size and potential of the market were:

- Demand for finance in the sector is 'enormous' but long-term modelling cannot take place in the absence of a certain legislative framework.
- The municipal energy efficiency market is estimated at 50bn HUF.
- Residential sector has the technical potential of many billions of Euros but is meaningless without an accompanying regulatory framework to include measures such as metering.
- Lenders are keen to exploit the potential that will arise from a growing awareness of the social and environmental benefits of sustainable energy.
- The market for cogeneration projects is already saturated.
- Biofuels are steadily rising and are supported politically.

<sup>1</sup> N.B. Around 30 ESCOs were identified and contacted for the purpose of this study, but it has not been possible to follow up on information requested in the short time-scale allowed.

<sup>2</sup> Kipcalor is expecting a 4,3 billion Ft in revenues with 260 million in net gains in 2004, which groups the company with the leaders of the EU market in the medium-sized businesses - said Ákos Pölczman, Financial Director of Kipcalor. The company, which became well-known for its reconstruction of energetic systems is about to enter the Slovakian and Romanian markets in the near future. (Source: MTI/ECONews (9 December 2003).)

**Table 2 Financing institutions attituded on sustainable energy borrowing**

Institution	Sector	RES	EE	RES & EE as proportion of overall activity	Source of co-finance	Loan conditions
Unicreditbank	Various	Yes	Yes	2/10 RES & 8/10 EE		
Commerzbank	Various	No	Yes	Not significant		Existence of off-take agreements.
K&H	Various (incl. Power sector and municipal sector)	Yes	Yes	25% to energy sector in general, 1/3 of which RES.	Own equity	20-25 if long-run contracts with MVM; Otherwise 5 years is normal. Clear ownership structures
Raiffeisen	Municipal	No	Yes	Not significant	Based on energy savings or performance contracting	
CIB	Power sector SMEs	Yes	No	<7%		Various
OTP	Corporate, household sector	Yes – developing new product	Yes – Panels Plus and Light of the Eye	<10%	Own equity	Various, depending on client

- Some large projects are at their planning stages, but variable in their quality and more potential exists for large projects.
- Large companies finance their energy efficiency investments internally, and since SMEs tend not to be energy intensive, EE is not a great priority for them.
- Market is most promising for projects >€4M.
- Based on both formal and informal enquiries from seekers of finance for RES and EE, one respondent indicated that their bank's financing could reach up to 100bln HUF. However, this would depend on the provision of appropriate state subsidy.

The expectations for new legislation are high and, if favourable, the financial institutions are keen to increase their lending with far greater confidence.

### **Risks and Barriers to Finance**

#### *Regulation and Legislation*

In almost all cases, the overriding and least manageable risk for the financial institutions was the lack of a stable and clearly defined legislative and regulatory framework governing the sustainable energy sector. This relates particularly to obligatory takeover (e.g. feed-in tariff price volatility and uncertainty). Currently, this overwhelms all other risk factors and is stifling investment in the renewable energy sector.

For energy efficiency, this is less of an issue. However, in that sector, the subsidisation of energy consumption is preventing market equilibrium.

#### *Institutional Capacity*

While institutional capacity within the major financial institutions was regarded as strong, it was felt that there are currently few project 'sponsors' that are capable of putting together strong projects. Even where confidence in business planning and project development exists, initiatives can be deterred by bureaucracy and lack of cooperation from key agencies. An example of this is in the planning approval process for RES projects.

Municipalities have limited resources for developing energy efficiency projects and lack capacity in financial aspects.

#### *Technological*

Technology risks were not considered to be of major concern for financiers, although the lack of maturity of RES technologies was mentioned.

Replicability of projects, however, is a factor that is hindering investment in the sector since most RES projects require specific business planning and tailored contracts.

#### *Political*

The lack of references to political barriers suggests that the political situation in Hungary does not present a major concern for this market. On the contrary, political will tends to support the growth of the market. It is hoped that political support will be translated into supportive legislation and regulation, and based on the financial sector's consultation in these areas, there is optimism that legislation will serve to boost rather than repress financial activity in the sector.

#### *Competition in Finance*

Competition in the sector was not perceived as being particularly high, with only 4-5 banks seen to be currently lending to the sector, and an insignificant level of foreign investment.

One respondent, however, suggested that there are rather more actors and institutions that are currently lending to the sector, ranging from consortia of banks as creditors to very large projects through to various funds, MFB (Hungarian Development Bank), cooperative programmes, operative programmes and subsidies from the National Development Plans or local or national government.

#### *Current Risk Mitigation Measures*

If overriding risk of regulation and legislation could be addressed, the less significant risks could be hedged with long-term contracts, as currently occurs. Examples of such risks include:

- Technological risks: construction, investment, installation, launching, operating
- Exchange rate and interest rate risks
- Environmental risk
- Energy prices
- Fuel supply (e.g. biomass)

These can be factored into contracts, when considering finance for projects.

For example off-take agreements (i.e. agreements between the project developer and the power purchaser or district heat companies), the feed-in tariffs 23.6 Ft/ kWh (note: presently a bit higher already, 24.7 Ft/ kWh)) and long-term power purchase agreements were mentioned by most respondents as necessary conditions for project financing. However, one particular bank indicated that they could not prescribe such conditions as off-take agreements and treat each case individually.

Foreign loans were also regarded as favourable, since they offer more attractive interest rates. However, these loans are subject to greater risk (of exchange rate volatility) and this risk has to be reduced through different types of counter-insurances.

The EBRD was seen to have an important role in supporting municipalities by providing guarantees. In general, energy efficiency projects have much lower risk than renewable energy, and also make more economic and environmental sense. In spite of the risks mentioned above, the financial institutions interviewed are successfully lending to the sector, and mitigate risks in the sector in the following ways:

- Consultation with the market actors in order to positively influence legislation.
- Strong business planning on the part of the borrower is essential but can only be economic in projects of a large magnitude because an investment of 100M HUF requires the same degree of planning as an investment as large as 1bln HUF. Bundling smaller projects to create a portfolio of consolidated credit demand can help to overcome this problem.
- Long experience in lending to the sector has generated market understanding which is a distinct advantage when considering finance for EE & RES projects.
- Finance through risk capital is one way of mitigating against legislative risk and addressing lack of own equity, but has disadvantages in terms of having to monitor the investor's interest.
- Barriers are often specific to individual projects. To overcome these barriers for the given project, the bank orders studies and considers experience from similar previous projects. Bank also takes part in helping outlining the governments subsidy system.
- PPAs cover financing.
- Feed-in tariff is 23.6 Ft/kWh (note: presently a bit higher already, 24.7 Ft/kWh)

### **Focus of Support**

For municipalities to respond to the potential for energy efficiency, there must be targeted support schemes. Otherwise, municipalities will opt for the lowest cost measures. In terms of support, there is a need to look at holistic and long-term options, such as district heating since piecemeal energy efficiency measures are not sufficient to address the problem of growing energy prices.

### **Conclusions**

The conclusions that can be drawn from this 'quick scan' of the market are based on quantitative data gathered in the two week research period, and are supplemented by the opinions of the financial stakeholders that it was possible to speak directly with. It should be noted that the data gathered is by no means sufficient to provide conclusive recommendations on either the viability of the SEFF in certain sectors or the market impacts of such a facility. There are some important gaps that must certainly be addressed, particularly in relation to the impact of an SEFF on ESCO activity, and potential of the SEFF to support ESCOs. However, the study does enable an indication of which sectors could benefit from a Sustainable Energy Financing Facility under current conditions. These are considered below.

### **Renewable Energy**

In the renewable energy sector, the uncertainty relating to the regulatory and legislative environment was mentioned time and time again by the financial institutions as a key barrier to investment, and tended to dominate all other concerns. Their is currently too much uncertainty for market actors in terms of legislation and regulation, and also a lack of transparency. Specifically, the uncertainty relates to the reform of the VET (Electricity Act), the liberalisation of the electricity market in 2007 and gas market in 2008 and review of long-term power purchase agreements (PPAs) by the EU.

The quantitative data also indicates that the potential uptake of finance for RES projects is limited by technical factors such as the cap on wind power capacity (350MW) and the lack of biomass resources.

Lack of capacity in this area on the part of project developers and the need for more international experience and replicable project development models were all mentioned as important issues that need to be addressed in order to grow the market.

### **Energy Efficiency**

Energy efficiency is clearly the most promising area of focus for the SEFF, based on current energy intensity, technical know-how and favourable payback periods for energy efficiency projects. The results of the research indicate the following in terms of sectoral focus for energy efficiency:

#### *Industrial sector*

Currently, energy intensity is high and there are significant energy savings to be made in the sector. This is even the case for SMEs in the sector, for example the chemical industries. However, energy efficiency is currently not seen as a priority in the non-energy intensive industries.

Highest energy-savings intensities were typical in the category of energy efficient products production, and supply of such services, or the complex energy supply investments in agriculture. Better than average is the energy savings figures in waste/waste-heat utilisation for energy production and electricity use reduction (by e.g. installing a gas motor). Least energy efficient investments were the insulation and the exterior/interior lighting/modernising. Among the sectors the construction sector and transportation, and the municipality sectors investment brought about the smallest results in energy-savings.

The value and potential of SEFF was considered to be in the financing of fewer large projects (>€4M), rather than many smaller projects (e.g. of <1M) over a three year period.

In order for SMEs to access this finance, however, their capital needs to be strengthened. EIB and EBRD are seen as key strategic partners in supporting this sector, for example by providing guarantees and re-insurances.

### **Recommendations**

- Focus of an SEFF should be on the industrial energy sector – there seems to be potential here and a lack of existing funding programmes, particularly those aimed at SMEs.
- Additional research is required on existing funds – where they have succeeded and failed, lessons which can be learnt and what is likely to happen in the future.
- Further information is needed about the municipal sector – not clear how their energy operations are run and what savings can be made – but on the face of it the buildings appear old and in need of improvement
- Renewables do not appear an attractive area to target – feed-in tariff already provides good support and the market is constrained by supply and regulation.

### **References**

- [1] Molnár M., Molnár S.: Hungarian Sustainable Energy Financing Facility – Quick Scan of the Market (JASPERS-EBRD/EIB - NFÜ, 2007, SEFF)
- [2] Molnár M., Molnár S.: Hungary - Market Study for Sustainable Energy Financing Facility (SEFF) Final Report, 2007, (hazai kutatásvezetőként, JASPERS- EBRD/EIB - NFÜ, 2007, SEFF), Industrial Energy Efficiency and Renewable Energy, Residential Energy Efficiency, Public Buildings Energy Efficiency
- [3] Renewable Energy and Sustainable Development in Hungary, *International Journal of Sustainable Development*, (2001), Vol 5, 1-2
- [4] Comprehensive Analysis of Greenhouse Gas Emissions in Hungary, *International Journal of Sustainable Development*, (2001), Vol 5, 1-2

## THEORY OF WOOD FIRING, SMALL BOILERS

István SZTACHÓ-PEKÁRY  
College of Kecskemét

### Introduction

In order for combustion to continue, there are certain basic conditions to be complied with [FALSTER, 1989]:

- an adequate mixture of fuel and oxygen (air) in a controlled ratio should be ensured,
- the fire already started in the boiler furnace should transfer some of its heat to the infeed in order to ensure a continuous combustion process.

It is important to understand that gases burn like flames, that solid particles glow, and that during the combustion of wood, approx. 80% of the energy is released in the form of gas and the remaining part from the charcoal.

During mixing of the fuel and air, it is important to achieve good contact between the oxygen of the air and the combustible constituents of the wood. The better the contact is the faster and more complete is the combustion. If the fuel is in the form of gas, such as natural gas, the mixing is optimal, since we have two gaseous substances that can be mixed to exactly the desired ratio. The combustion may then occur rapidly, and thus the control is fast too, since we can introduce more or less fuel. In order to achieve approximately the same situation with wood, it may be necessary to pulverize the wood to very small particle size (like that of flour). These fine particles will follow the movements of the air. A good mixture can thus be achieved with a combustion resembling a gas or oil flame. The production of wood powder is very expensive, though, and therefore wood powder is not used in Hungary. In practice, fuel is therefore marketed in sizes varying from wood chips to logs.

Firing technology for wood and other solid fuels is thus difficult and more complicated than for example the firing technology in a natural gas or oil-fired heating system.

### Stages of combustion of wood

In order for combustion to occur, the fuel must pass through three stages, which are shown in Figure 1.

- drying,
- gasification and combustion,
- charcoal burnout.

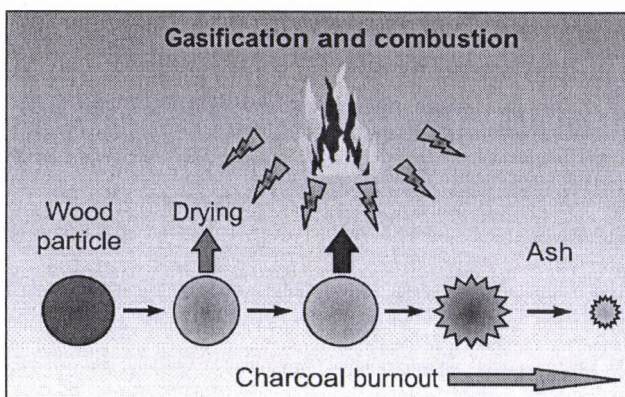

Figure 1 A wood particle combustion route

When wood is heated, water begins evaporating from the surface of the wood. Hence two things occur: gasification occurs at the wood surface – pyrolysis (the heating of a fuel without the introduction of gasification medium, i.e. oxygen and water) – and the temperature deeper inside the wood will increase resulting in evaporation of moisture from the interior of the wood. As the water evaporates and is passed away, the area that is pyrolysed spreads into the wood.

The gas thus produced is ignited above the fuel and transfers heat to the ongoing evaporation and pyrolysis. The combustion process is continuous. The gasified wood becomes glowing charcoal, transformed by oxygen, until only ash is left.

### Technological parameters of the combustion

#### Fuel Size

The larger the fuel particle is, the longer is the combustion process. I. e. the burning of the sawdust is quickly and the burning of a log is slowly. In the first case there is a good contact between fuel and air, since the small particles quickly dry, give off gases and burn, resulting in high combustion intensity; in second case the burning will take a long time before it is burnt out.

The size of the fuel, therefore, is of great importance to the speed of combustion.

#### Moisture Content

The moisture content in fuel reduces the energy content expressed by the calorific value, since part of the energy will be used for evaporation of the water. Dry wood has a high calorific value, and the heat from the combustion should be drawn away from the combustion chamber in order to prevent over heating and consequent damage to material. Wet wood has a low calorific value per kg total weight, and the combustion chamber should be insulated so as to avoid reduction in boiler efficiency and enable a continuous combustion process. This is typically accomplished by using refractory linings round the walls of the chamber so as to conserve the heat which is generated. The boiler chamber will therefore normally be designed for burning wood within a certain moisture interval.

Moisture content in wood above 55-60% of the total weight will make it very difficult to maintain the combustion process.

#### Ash Content

The fuel contains various impurities in the form of incombustible component parts – ash. Ash itself is undesirable, since it requires purifying of the flue gas for particles with a subsequent ash and slag disposal as the result. The ash contained in wood comes primarily from soil and sand absorbed in the bark. A minor proportion also comes from salts absorbed during the period of growth of the tree.

The ash also contains heavy metals, causing an undesirable environmental effect, but the content of heavy metals is normally lower than in other solid fuels.

A special characteristic of ash is its heat conservation property. For wood stoves, the ash layer at the bottom of the stove forms a heating surface, transfer ring heat to the final burnout of the char. For heating systems using a grate, the ash content is important in order to protect the grate against heat from the flames.

Wood also contains salts that are of importance to the combustion process. It is primarily potassium (K) and partly sodium (Na), based salts resulting in sticky ash which may cause deposits in the boiler unit. The Na and K content in wood are normally so low that it will not cause problems with traditional heating technologies.

#### Volatiles

Wood and other types of biomass contain approx. 80% volatiles (in percentage of dry matter). This means that the component part of wood will give up 80% of its weight in the form of gases, while the remaining part will be turned into charcoal. This is one reason why a sack of charcoal seems light compared to the visual volume. The charcoal has more or less kept the original volume of the green wood, but has lost 80% of its weight.

The high content of volatiles means that the combustion air should generally be introduced above the fuel bed (secondary air), where the gases are burnt, and not under the fuel bed (primary air).

### Excess Air

A given fuel requires a given amount of air (oxygen) in order to be converted stoichiometrically, i.e. the amount of excess air  $\lambda$  (lambda) should be equal to 1. The fuel is converted stoichiometrically when the exact amount of oxygen that is required for the conversion of all of the fuel under ideal conditions is present. If more oxygen is introduced than an amount corresponding to  $\lambda$  equal to 1, oxygen will be present in the flue gas. At, e.g.  $\lambda$  is equal to 2, twice as much air is introduced as necessary for the combustion of the fuel.

In practice, combustion will always take place at an excess air figure higher than 1, since it is not possible to achieve complete combustion at a stoichiometric amount of air. Ideal combustion of wood takes place an excess of air between 1.4 and 1.6. The oxygen percentage in the flue gas will thus be 7.5%.

### Small boilers

Distinctions should be made between manually fired boilers for fuelwood and manually fired boilers for fuelwood and wood pellets. Manually fired boilers should be installed with storage tank so as to accumulate the heat energy from one infeed of fuel (a full magazine). Automatic boilers are equipped with a silo containing wood pellets or wood chips. A screw feeder feeds the fuel simultaneously with the output demand of the dwelling.

Great advances have been made over the recent 10 years for both boiler types in respect of higher efficiency and reduced emission from the chimney (dust and carbon monoxide (CO)). Improvements have been achieved particularly in respect of the design of combustion chamber, combustion air supply, and the automatics controlling the process of combustion. In the field of manually fired boilers, an increase in the efficiency has been achieved from below 50% to 75-90%. For the automatically fired boilers, an increase in the efficiency from 60% to 85-92% has been achieved.

### Nominal output

The boiler nominal output (at full load) can be calculated on the basis of the known annual consumption of oil or the floor space and age of the dwelling (and insulation).

### Manually Fired Boilers

The principal rule is that manually fired boilers (Fig. 2) for fuelwood only have an acceptable combustion at the boiler rated output (at full load). At individual plants with oxygen control, the load can, however, be reduced to approx. 50% of the nominal output without thereby influencing neither the efficiency nor emissions to any appreciable extent. By oxygen control, a lambda probe measures the oxygen content in the flue gas, and the automatic boiler control varies the combustion air inlet. The same system is used in cars. In order for the boiler not to need feeding at intervals of 2-4 hours a day, during the coldest periods of the year, the fuelwood boiler nominal output is selected so as to be up to 2-3 times the output demand of the dwelling.

Boilers designed for fuelwood should always be equipped with storage tank. This ensures both the greatest comfort for the user and the least financial and environmental strain. In case of no storage tank, an increased corrosion of the boiler is often seen due to variations in water and flue gas temperatures, and in addition to that, the manufacturer warranty may also lapse.

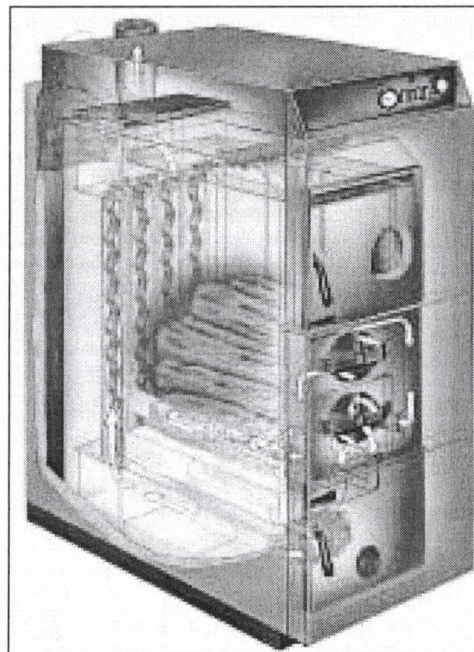

Figure 2 "X-ray" of manually fired boiler

### Automatically Fired Boilers

Despite an often simple construction, most of the automatically fired boilers can achieve an efficiency of 80-90% and a CO emission of approx. 100 ppm (100 ppm = 0.01 volume %). For some boilers, the figures are 92% and 20 ppm, respectively. An important condition for achieving these good results is that the boiler efficiency during day-to-day operation is close to full load. For automatic boilers (Fig 3.), it is of great importance that the boiler nominal output (at full load) does not exceed the maximal output demand in winter periods. In the transition periods (3-5 months) spring and autumn, the output demand of the dwelling will typically be approx. 20-40% of the boiler nominal output, which means a deteriorated operating result. During the summer period, the output demand of the dwelling will often be in the range of 1-3 kW, since only the hot water supply will be maintained. This equals 5 -10% of the boiler nominal output. This operating method reduces the efficiency – typically 20-30% lower than that of the nominal output – and an increased negative effect on the environment. The alternative to the deteriorated summer operating is to combine the installation with a storage tank, oil-fired furnace, electrical power heated hot water supply or solar heat.

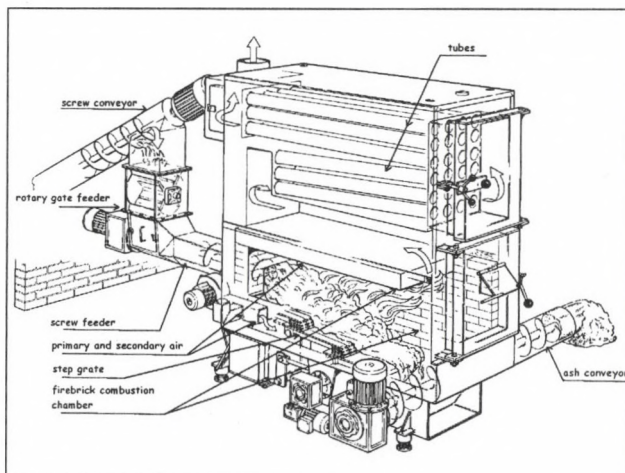

Figure 3 Automatic chip-fired system

## Experiences and future developmental requirements

Since the fabrication a wide range of experiences has been acquired from small heating systems. It was obvious at the beginning that many manufacturers were marketing heating systems, whose output exceeded by far the heat demand of ordinary dwellings. This resulted in an obvious disparity between the actual demand of the consumers and the supply of heat by the heating systems with an output of less than 20 kW. The situation has changed since then, and the greater number of manufacturers by far now offer systems with outputs in the range of 10-20 kW, or are developing new systems. The small systems are often designed for wood pellets or perhaps for cereals. There is still a need for improvements of boiler efficiencies. Several concepts are being developed at present, e.g.:

- improvements of the boiler convection unit so as to reduce the flue gas temperature from the present 250-300 °C to 150-200 °C,
- improvements of the lining (for wet fuels) and the design of air nozzles so as to keep constant the excess air and CO<sub>2</sub> contained in the flue gas thus at the same time contributing to reduce dust emissions. Note that dust emissions do not always depend on the combustion. Variations in fuel quality may result in variations in emissions,
- improvements of the boiler control equipment so as to ensure an environmentally desirable and energy efficient optimal operation at the same time as being highly user-friendly requiring only minimal weekly attendance. Note that several boilers have advanced controls with several output options, and sometimes also oxygen control which to a high extent can

handle the variations in consumption in a typical central heating.

- improvements of the low-load properties so as to maintain an acceptable operation during the summer period.

## References

- [1] BACKMAN, R – M. HUPA – B.-J. SKIFVARS (1997): Predicting superheater deposit formation in boilers burning biomass. *Proceedings on the conference on Impact of mineral impurities in solid fluid combustion*, 406-415 p.
- [2] BARÓTFI I. ED (2002): Környezettechnikai kézikönyv. *Környezettechnikai Szolgáltató Kft*, (Budapest) 536 p.
- [3] BUTCHER, B.T. – N.J. DOLL, (1985): Respiratory Responses to Inhaled Small Organic Molecules and Related Agents Encountered in the Workplace. *Clinical Reviews in Allergy*, 3. sz. 351-361 p.
- [4] FALSTER, H. (1989): Fyringsteknologi, andre brændsler. In: Bech, N. & Dahlin, J. (ed.) 1989. Forbrænding teori og praksis. *Polyteknisk Forlag* (Kopenhagen)
- [5] NIELSEN, K. H. (1989): Storage of Chips under Roof. Research report nr. 6, *Danish Institute of Forest Technology*, (Kopenhagen) 36 p.
- [6] NUSSBAUMER, T. (1997): Primary and secondary measures for NO<sub>x</sub> reduction in biomass combustion. In: Development in Thermochemical Biomass Conversion. *Blackie Academic, Chapman & Hall*, (London) 1447-1462. p.
- [7] SERUP, H. ED (2002): Wood for energy production: technology – environment – economy. *The Centre of Biomass Technology*, (Kopenhagen) 69 p.

## DEVELOPMENT OF FOREST MACHINE IN RECENT PAST IN HUNGARY

Béla HORVÁTH

Institute of Forest- and Environmental Techniques, University of West Hungary, Sopron

### Introduction

Forestry mechanization must satisfy the expectations of home forestry management. Its main parameters are as follows:

- forest area: 1,86 million hectares, 20% of the total area of the country;
  - total stock of green trees: c. 330 million cubic meters (100%);
  - annual tree growth increment: c. 12 million cubic meters (4% of total green tree stock);
  - annual allowable cut: c. 7 million cubic meters (only 2% of total green tree stock, meaning there is no extravagant exploitation of forests in Hungary);
  - annual forest renewal obligation: 20.000 hectares;
  - pre-planned forest area growing (in the next 30 years): 450.000 hectares;
  - pre-planned general annual afforestation: 15.000 hectares.
- (The above data refer to traditional forests).

Forest management uses a number of agricultural machines (power machinery, cultivating machines, plant protecting machines) and a high volume of special forestry machinery. As an interesting addition, forest management in modern Hungary uses a lot of power machinery. Seventy percent of the machinery is universal agricultural tractors. Only the remainder is special forestry machines. The technical level of forestry machinery is generally affected by the level of the agricultural machinery. Most of our special forestry machines are supported locally (as the product of agricultural machinery producers, but we also import machines). This analysis focuses on the development of home produced forestry machinery.

### Characteristics of forest machine developments

The local forestry machine development and machine production stopped in Hungary by the end of the 1980s. Before that time, several machines were developed and produced which were well utilized. They were nicely adapted to Hungarian conditions. Until the end of the 1980s, there was a technical development background, as the basis for home production of forestry machinery. After this time, a big decline resulted in the almost total stopping of production. It almost ended with the liquidation of the Section of Forestry Mechanization of the Hungarian Forest Research Institute. Thanks to the activities of certain organizations, such as the Institute of Forest- and Environment Techniques at the University of Western Hungary, the Section of Forestry Mechanization at the Hungarian Forestry Association, the Technological Section of the Association for the Hungarian Plain's Forests and several other forestry companies these negative trends of machine development of forestry machinery were stopped, and a positive new trend began in machinery production. There are 90 companies dealing with agricultural machine production in Hungary. Only ten produce forestry machinery. Some of them are as follows: Agrikon Solt Gépplyártó Zrt. (Solt), Bagodi Mezőgép Kft. (Bagod), ERDŐGÉP Kft. (Kaposvár), Kaposgép Kft. (Kaposvár), "Pletnyik" Gépplyártó- Tervező és Szolgáltató Kft. (Kiskőrös), RÁBA Jármi és Buszgyártó Kft. (Győr), Optigép Kft. (Békés).

The production of forestry machines in Hungary operates on a market basis, but it can survive only with a technical development background. This development can be imagined with a basis that ensures the cooperation of forestry machine research and development activities.

Recently, after 1990, the following forestry machines have been produced in Hungary:

- seedling production machine line in relation with seedling production;
- machinery for silviculture: tillers, strip plows, forestry soil looseners, strip soil preparators, sowing devices, tree planting machines, sapling planting machines, hole diggers, stem crushers, and afforestation machine line;
- machinery for forest utilization: hydraulic grapples, hydraulic crane trailers, forestry trucks, hydraulic cranes, cable ways, splitters, chippers, and energy tree plant harvesters;
- machinery for forest protection: forest fire suppression equipment.

There are many different types of machines mentioned in plural. Those mentioned in singular have only one type.

Forest machinery producers today produce 70 different forestry machines based on the development so far. In the future they will probably increase. These machines can be used in about 30 forestry operations, not mentioning machines used only in agriculture.

### Tasks for development

Tasks for today and the near future:

- continuous development of machines that have been produced;
- the development of traditional forestry machines which are new to the current forest management, i.e. (site cleaners, grouting machines, chemical slashers, barkers);
- machine development which promotes the energetic usage of wood (planter and harvester machine line for short rotation energy tree plants, planter and harvester machine line for roundwood growing energy tree plant, harvester machine line for the underwood level of flood plain forests).

The new development ideas result from the fact that there has been a dynamic development in the energetic utilization of biomass in Hungary, especially because of the large consumption of power stations. The total quantity of wood that is cut from traditional forests for use as fuel is consumed for home heating and power stations. However, there is some reserve in by-products from the cutting areas. We also have some reserves in the woody parts of the underwood level of flood plain forests. The continuous production of underwood level of flood plain forests accounts for flood protection.

Procurement of these levels of quality was not possible due to economic considerations.

Certain machinery developments might be done to make the production process economical. Energy production based on woody bio-mass can only be increased if new planting is done in the future. The mechanization of for a short cutting cycle for wood production for energy and for the production of round wood has not been satisfactorily solved. We need the formation of synchronized machinery. These types of machines might not show particular differences for plantation tilling, but there will be a significant difference in the harvesting operation depending on the quality and size of wood to be harvested. The short felling cycle for energetic wood plants will produce wood materials between 1 and 5 cm with a 1 - 2 year felling cycle. Round wood energetic wood plantations have a longer felling cycle (3.5, or 10 years) producing wood with 10 - 15 cm stem diameter. The collection of the woody parts of flood plain forests needs a different harvesting machine.

This means the machine developments used for production of wood for energy are as follows:

- the formation of complex machinery for short rotation energy tree plants is built on the development up to now (planting and tilling machines may be built on the mutual develop-

- ments of Bagodi Mezőgép Kft. and the Institute of Forest- and Environment Techniques of the University of Western Hungary);
- the formation of complex machinery for roundwood grower energy tree plants built on the development so far, planting and tilling machines may be built on developments of Bagodi Mezőgép Kft. and the Institute of Forest- and Environment Techniques of the University of Western Hungary);
- the formation of the harvester machine line for underwood level of flood plain forests (steps towards this started at the Délalföldi Erdő- és Fagazdaság Zrt.) and the Institute of Forest- and Environment Techniques of the University of Western Hungary);
- the choice of bundling machines that assure the collection of felling waste. These machines still exist. The optimal conditions to apply them must be created in Hungary.

Forest management in Hungary needs only a few samples of forestry machinery due to the territory of forests. Therefore the Hungarian forestry machinery development and production can only be maintained if we take special interest in its financial support. Those who take part in this project must work together in research and development. These institutions must be mentioned: Institute of Forest- and Environment Techniques of the University of Western Hungary, the Agricultural Machinery Institution of FVM (Ministry of Agriculture and Rural Development) and determinant forestry machine producers. Their cooperation is inevitable and they should work together in relation with the investigation of values, too.

### Recommendations

1. Currently about 90 companies produce agricultural machinery in Hungary but only ten of them produce forestry machinery. National forestry machinery production can only operate if the background of technical development can be improved. The development needs support which ensures the cooperation of technical development, research of forestry machinery and research and development. We must maintain the national development of forestry machinery for the effectiveness of forest management, too.
2. Forestry machine producers today create about 70 different forestry machines based on earlier developments. These types are used to operate 30 different forestry processes. We do not count those which are also agricultural machines. It is necessary to develop the machines that were produced earlier and we must also develop those machines which were not produced at home, but only abroad.
3. We particularly have to focus on the machine development that utilizes wood in energetics. With special regard to:
  - the formation of complex machinery for short rotation energy tree plants is built on the development up to now (planting and tilling machines may be built on the mutual developments of Bagodi Mezőgép Kft. and the Institute of Forest- and Environment Techniques at the University of Western Hungary);
  - the formation of complex machinery for roundwood grower energy tree plants built on the development so far, planting

- and tilling machines may be built on developments of Bagodi Mezőgép Kft. and the Institute of Forest- and Environment Techniques at the University of Western Hungary);
- the formation of the harvester machine line for underwood level of flood plain forests (steps towards this started at the Délalföldi Erdő es Fagazdaság Zrt.) and the Institute of Forest- and Environment Techniques at the University of Western Hungary);
- the choice of bundling machines that assure the collection of felling waste. (These machines still exist. The optimal conditions to apply them must be created in Hungary).

4. It is necessary for organizations which take part in research and development to work together. These institutions are the Institute of Forest- and Environment Techniques at the University of Western Hungary and the Agricultural Machinery Institution of FVM (Ministry of Agriculture and Rural Development.) Their cooperation must be a problem solving activity. This might also mean the investigation of values, and the synchronization of research and development must be proved. The investigation of values must be accomplished from day to day.

5. The national forest management and wood energetics needs only a couple of samples of certain types of machines. Therefore production of Hungarian forestry and machines of wood energetics can only be maintained if these processes are supported and taken care of. The system of support for machinery development and production for Hungarian forestry and wood energetics must be created and then maintained.

### Acknowledgements

This research-development was completed within the research project of ERFARET-03/2004, financed by NKTH.

### References

- [1] HORVÁTH, B. (1996): The Situation and Future of Forestry Machinery. *Mezőgazdasági Technika*, XXXVII. 8: pp 8-9.
- [2] HORVÁTH, B. (2001): The Situation of Mechanization in Forest Management and its Chances to Develop. A bulletin of the year 2000 for the Department of Agricultural Sciences of MTA (Hungarian Academy of Sciences) *Agroinform Kiadó és Nyomda Kft.*, Budapest pp 192-198.
- [3] HORVÁTH, B. (2007): Machines to Harvest Plants with Aims of Energetics. *Erdészeti Lapok*, CXLII, 7-8: p 271.
- [4] HORVÁTH, B. - JUNG, L. - KAKNICS, L - SZABÓ J. (2007): Wood Utilization with Aims of Energetics and its Mechanization. *Erdészeti Lapok*, CXLII. 4: pp 129-130.
- [5] MAROSVÖLGYI, B. - KÜRTÖSI, A. - PÜSKI, J. (2003): New Results of Experiments for the Mechanization of Wood Utilization Aiming at Energetics. Committee for Agriculture and Technique of MTA. Published for the R and D talks, Gödöllő. Nr.27.1: pp 182-186.
- [6] SOLYMOS, R. (1997): The Quality Development in Forest and Wood Industry. "AGRO-21" editions. The Future-Prospects of Agroecconomics. 16: pp 3-19.

## EXPERIMENTAL PAVEMENTS BUILT ON COHESIVE SOIL

József PÉTERFALVI - Miklós KOSZTKA - Gergely MARKÓ - Péter PRIMUSZ  
University of West-Hungary, Faculty of Forestry, Institute of Geomatics and Civil Engineering

### Experimental road-section

The 580m long experimental road section is located at the Forestry of Bánokszentgyörgy in Zala County, which belongs to the *Zalaerdő Forestry Closed Company*.

The subgrade of the experimental road was constructed using the clay soil in place. The most important soil physical properties are as follows:

- Liquid limit:	44.6%
- Plastic limit:	22.4%
- Plasticity index:	22.2%
- Flow index:	18.4%
- Maximum dry density:	1.82g/cm <sup>3</sup>
- Optimum water-content for compaction:	15%

The 15-25-35cm lime stabilization layer was built using local soil in the first 360m. Nine different pavements were built with asphalt and macadam surfaces in different thickness in 40m length each. A traditional pavement - without lime stabilization - was built in the last 220m as a control section. Table 1 shows the pavements.

Three different pavement courses were designed on the lime stabilization layer:

- Well graded crushed dolomite course,
- Hot asphalt base course,
- Finnish asphalt course.

The different pavement versions were designed with about the same design bearing capacity. This equivalent thickness was 30cm. The road sections with the same lime stabilization layer thicknesses were placed next to each other.

To better understand the bearing capacity of the lime stabilization layer, the 9th pavement version was built with just 35cm lime stabilization layer and with 2cm of fine crushed stone.

Constructing the lime stabilization layer was done as follows:

- pumping powdered quicklime into the binding material feeder,
- bringing the binding material feeder to the starting point of construction,
- calibrating of the binding material feeder,
- checking of the binding material feeder,
- spreading of the binding material,
- mixing with a soil milling machine,
- compacting with the vibration roller.

The binding material feeder spread the powdered quicklime on the whole surface of the subgrade in two passes. The spreading did not overlap; therefore the spreading was in accordance with the plan. The soil milling machine performed the mixing in two courses with overlapping. During the mixing the machine performed the setting of the thickness of milling automatically. The production line finished the lime stabilization with three different thicknesses and a width of 3.50m in three hours.

### Change of the bearing capacity

Before construction the bearing capacity of the subgrade was very low because of the soaked soil layer was 20-50cm thick. After building the lime stabilization layer, the bearing capacity has increased significantly (figure 1.).

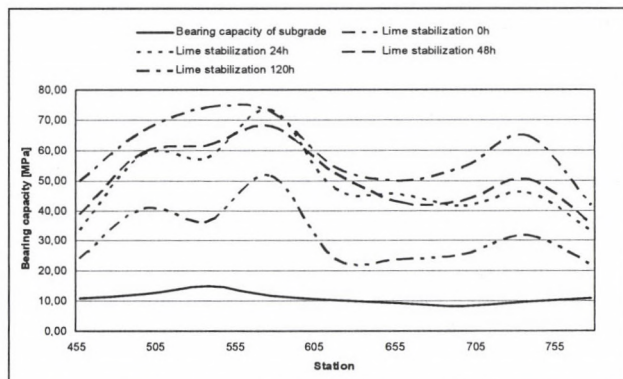

Figure 1 Increase of bearing capacity the action of lime

After construction of the complete pavement the static bearing capacity was 40-70MPa. Traffic was simulated with loaded trucks with different weights, which were converted into equivalent standard axle load (ESAL) traffic. Before and after the artificial traffic the condition of the road sections was assessed by visual observation, and the bearing capacity of the sections was determined with the help of deflection measurements and static and dynamic bearing capacity measurements. The values show well the decrease of the bearing capacity due to the traffic (figure 2.).

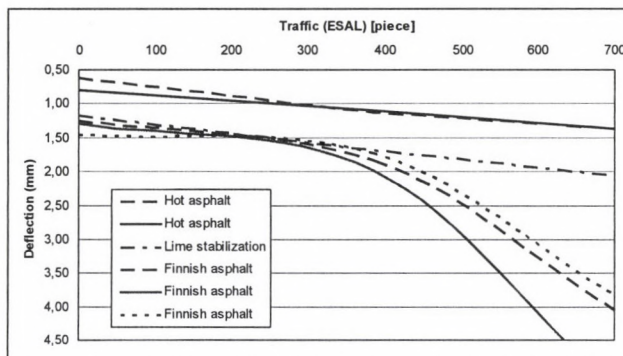

Figure 2 Relationship of the traffic and the deflection at the pavement-variations

The damage to the pavement occurred in four sections. Two were covered by Finnish asphalt, one by hot asphalt and the fourth was a section of the control pavement. At the damaged pavements with asphalt surfaces, there was a relatively thin (10-15cm) crushed stone course under the asphalt.

### Evaluation of measurements and conclusions

The bearing capacity of all sections decreased after the last artificial traffic. A significant volume of precipitation during the traffic also contributed to the decrease of the bearing capacity. This theory is corroborated by the excavation of the pavements. Water seeped into the thin crushed stone course through the cracked asphalt surface, in which shear strength decreased because of the increased pore water pressure; crushed stone pressed out on the side. The water content of the lime stabilization was increased by the pumping effect of the artificial traffic; therefore its bearing capacity decreased.

The conditions of the sections are as follows:

- the pavements with asphalt surfaces and thicker crushed stone courses resisted more to the harmful influence of the artificial traffic,
- the macadam pavements built on lime stabilization better followed the reduction of bearing capacity of subgrade,
- the section with 35cm lime stabilization, which has just 2cm fine crushed stone, also resisted the artificial traffic.

### Further plans

To confirm results and conclusions till now, we are planning to repair the damaged sections of macadam pavement and to continue the artificial traffic. After concluding the series of tests at the end of 2008 we will be able to recommend pavements variations.

### References

[1] Kosztka M.-Markó G.-Péterfalvi J.-Primusz P. (2007): Experimental pavements built on hard ground. In: Landscape Management - Present and Future International

Scientific Conference, Bruno-Krtiny, Czech republic, Conference abstracts proceeding p. 15. Mendel University of Agriculture and Forestry in Brno. (13-14. 09.)

- [2] Mallela J.- Quintus H. - Smith K. L. (2004): Consideration of lime-stabilized layers in mechanistic empirical pavement design. The National Lime Association, Virginia.
- [3] Primusz P.-Péterfalvi J.-Kosztka M.-Markó G. (2008): Bearing Capacity of Lime Stabilized Soils. Forest Constructions in the Country and their Recreational Use, International Scientific Conference - Collection of papers of international scientific conference (CD). Technical University in Zvolen, Slovak Republic. (16. 10.)

# A COMPARATIVE STUDY ON THE PERFORMANCE OF THREE DIFFERENT BAND SAW BLADES

Kinga GERENCSÉR - Erzsébet VARGA

University of West Hungary, Institute of Wood and Paper Industry

## Introduction

Manufacturers of band saw blades for the sawmilling industry are continuously modifying their products in order to improve the quality yield at the mills. These innovative blades appear periodically on the market. The purpose of these innovations is manifold, including the development of more durable cutting edges, development of band blades to provide more size accurate lumber with enhanced surface quality. The superior durability of cutting edges allows the elongation of time between two sharpening processes thus; significant cost and energy savings may be achieved. Furthermore, size accuracy and surface roughness have considerable influences on the quantitative and qualitative outcome. Removing oversized materials, and eliminating surface roughness or waviness decrease the yield and requires extra time and energy from both the mill and from the secondary processing industry. Consequently, the periodical evaluation of band saw blades compared to the performance of newly developed tools has practical value for the saw milling industry and that was the general objective of this work.

## Background

After mechanical processing (saw milling) of logs, different irregularities can be observed on the surface of the lumber produced. Main features of the surface quality are waviness, surface roughness, as well as deformation and densification of the upper layers of wood material. Furthermore, surface roughness is defined as a series of grooves and ridges on the sides of a lumber. There are several factors influencing surface roughness that can be divided into two basic groups namely: parameters of the mechanical transformation and the anatomical features of the milled wood species. [1,2].

Saw teeth make periodically repeating marks on the surface of the lumber. These replicated surface marks are depending on the feed rate per tooth of the sawing operation. Quality of the surface created by saw milling is influenced by several factors, including vibration and other type of kinematic irregularities, divergence of tooth tips due to improper spring-, swage-setting and satellite coating, and other technological irregularities (fuzzy grain, splintering, etc.) [3,4,5].

During mechanical transformation, the target shape and size of the stock can be ensured only if the tool – the band saw blade – works firmly without any major deviations. The loss of stability of the band is indicated by the drifting of the blade from its intended pathway. This drifting is caused by eccentric and side forces acting to an angle to the blade's plane. Initiation of these forces may be attributed to the imperfections of the blade and/or the inhomogeneity of the stock. Increasing feeding force results in increased drifting.

Out of plane deviation of the blades - that is defined as the torsion-deformation of the band - initiate surface problems too. Even a minor out of plane deviation of the blade can cause torsion moments against the feeding force. The blade buckles sideway and due to the torsion vibration sawing marks could be observed on the surface of the lumber decreasing the quality of the product.

By examining the out-of-plane deviation of the blade, it has to be taken into account that the machine, the blade and the wood material make up an oscillating system. The vertical alternation of the machine is small although oscillation of the blades is a significant influencing factor. These oscillations are induced by

external forces, such as cutting force or may originate from imperfections of the blade and the welding of the blade. Furthermore, may be generated by the eccentricity of the tension and driven wheels. The gripping of the processed log is not always stiff that may trigger oscillations. Further oscillations can be caused by the change of the blade tension force during the operation as a result of thermal expansion of the saw blade [6].

To minimize the friction between the blade and the log, side clearance is necessary, that is the difference in thickness of the blade and the width of the kerf. The first solution to provide side clearance was the development of spring-set teeth where the subsequent teeth are bent out from the plane of the blade to the left and right directions alternately. Over the years, the quality requirements induced the development of swage-set teeth where the tip of the teeth are broadened by cold pressing to make the produced kerf wider than the thickness of the blade. The hardness of the swaged edge may be improved by 20%. Hardening is achieved by the ductile, cold deformation [7]. Saw teeth are treated with stellite coat for improving edge durability. Stellite is a hard metal alloy with high cobalt and wolfram and low iron content. Its hardness is around 48-50 HRC. Advantages of satellite coating include: relatively high wear resistance and the possibility of grinding sharp, small cutting angle teeth. [2,3,9,10].

## Materials and Methods

Currently, swaged-set and satellite tipped band saw blades are used for band sawing operations in Hungary. This study evaluated the performance of the above types of saw blades along with a newly developed band blade. Comparisons were made by blade types.

Band saw blade, -developed by A-Lap Kft.- belongs to the group of stellite tipped blades, although the geometry of the blade is significantly differs from this general group of blade types. The detailed description of this new saw blade is intentionally omitted because the product is still patent pending.

The following species were involved in the study: black locust (*Robinia .....*), oak (*Quercus .....*), poplar (*Populus ...*), pine (????...). For black locust and oak, we processed four logs for each species and the three band type combinations. While for poplar and pine only the satellite-coated and the new blade were evaluated using four logs by species/blade type combinations.

Target thickness was established as 30 mm. Sawing parameters were set according to the real operating conditions. Cutting height does not have significant influence on the measured parameters because these dimensions varied only slightly given that the diameters of the logs were about 180 – 400 mm. The experimental work was performed on a band saw machine (**a gép parameterei?**) operating at the KARDEX Kft., Turje, Hungary. Necessary instrumentations were installed with the assistance of the A-Lap Kft.

We measured the feeding speed with a BDG63002-05 E 1000-65 type rotational indicator mounted on the shaft of the log carriage towing-cable drum. It should be noted however, that the operator subjectively adjusts the feeding speed. Thus, the theoretical feeding speed is only a pilot value.

A BAW M18ME type induction type indicator collected data for blade drifting. The device was mounted on the upper blade guide. Eight similar sensors were attached to the guide at the returning side of the band collecting out-of-plane deviation data. All electronic data collection happened simultaneously in real time.

Thickness measurement happened at both edges at every 200 mm of the length of the lumber in order to confirm the parallelism of the sides. Thickness measurements were performed at the top and bottom edges of the lumber regarding its position in the machine. We used one lumber cut out of black

locust and poplar logs for size accuracy measurements using a Mitutoyo-type digital caliper having  $\pm 0,01$  mm accuracy. Surface roughness measurements were performed by using a Mahr Perthen S3P, stylus tipped roughness tester. The instrument scans the surface along a line using a stylus type sensor. The result is a 2-dimensional profile of the rough surface [11]. The observed values were used to calculate the average roughness of the lumber ( $R_z$ ) which is the average of the five highest and five lowest measured deviations along the pass line of the instrument. Measurements were applied on five samples per each wood species.

## Results and Discussion

### Blade drifting

**Table 1** shows the average blade drift values. As one can observe, sawing with the new blade resulted in the smallest blade drifting for all four species. An average of 15  $\mu\text{m}$  decrease of blade drifting was observed for oak and black locust by using the newly developed blade. Compared to the swage-set blades, for poplar and pine, the decrease of blade drifting – 65  $\mu\text{m}$  and 115  $\mu\text{m}$ , respectively – was even more significant. It means that for poplar approximately 20% and for pine about 35% decrease of blade drifting can be achieved by the application of new blade. The better blade drifting performance of these species may be attributed to the anatomical characteristics of poplar and pine.

### Out-of-plane blade deviation

The average out-of-plane blade deviation values are summarized in **Table 2**. According to the observed data, blade deviations demonstrated both negative and positive values for all species/blade combinations. However, these deviations are

not significant and measuring up to just tenths of a millimeter. One can conclude that the out-of-plane deviation of the blade is not influenced by the type of blade configuration.

### Size accuracy

**Table 3** contains the size deviations for black locust and poplar by the used blade types. The satellite coated blade demonstrated the largest deviations from target values. The new blade performed significantly better in approaching the target thickness, both at the upper and lower measuring locations. However, the thickness deviations were always higher at the lower side for all species/blade combinations. This phenomenon may be explained by the fact that at the lower 1/3 of the depth of cut the gullets of the blades are already filled up with saw dust creating unstable drifting situations. Differences between the target thickness and actual thickness were positive at the first half length of sawing and were negative at the second half. Considering first the upper differences, the new blade kept the target value by 30% better than swaged and satellite-tipped blades for black locust. We did not saw poplar logs with swage-set teeth blade. Thickness of poplar lumbers sawed with the new blade was 30% closer to the target values if compared to the size accuracy of the satellite-tipped blade. Examining the lower differences, one can conclude that for black locust the size accuracy of the new blade improved by 20% and 30% if compared to the swage-set and satellite coated blades, respectively. The size accuracy of poplar cut with the new blade demonstrated 25% improvement compared to the performance of satellite coated blade.

### Surface roughness of the lumbers

**Table 4** contains the calculated  $R_z$  values of surface roughness measurements. The surface roughness of lumbers sawed with

**Table 1** Average blade drifting of different species/blade combinations

Species	Swaged teeth blade		Stellite tipped blade		New blade	
	Average blade drift ( $\mu\text{m}$ )	Standard deviation	Average blade drift ( $\mu\text{m}$ )	Standard deviation	Average blade drift ( $\mu\text{m}$ )	Standard deviation
Black locust	-341,7	138,5	-355,49	121,4	-329,21	150
Oak	-375,11	147,7	-335,48	130,5	-318,48	155,5
Poplar	-	-	-351,27	140	-286,52	189,3
Pine	-	-	-366,31	155,8	-251,07	170,9

**Table 2** Average out- of-plane blade deviation values

Designation	Blade deviation's test point							
	0	1	2	3	4	5	6	7
	Average blade deviation ( $\mu\text{m}$ )							
Black locust – swaged blade	-15	137	389	83	501	495	472	453
Black locust – stellite tipped blade	-414	-311	88	-360	308	149	262	289
Black locust – New blade	-211	-54	325	-263	346	128	470	151
Oak – swaged blade	-258	-227	-13	-431	122	15	-114	-174
Oak – stellite tipped blade	-377	-271	46	-449	79	-241	-232	-174
Oak – New blade	-281	-205	124	-418	20	-275	239	-272
Poplar – stellite tipped blade	-356	-291	-29	-396	183	-1	126	178
Poplar – New blade	-316	-234	106	-397	107	-138	319	-108
Pine – stellite tipped blade	-362	-242	166	-342	372	214	324	343
Pine – New blade	-321	-227	155	-434	135	-206	403	-193

**Table 3** Average deviations from the target thickness species/blade type combinations

Wood specie	Blade type	Deviation of the upper thickness size from the target value (mm)	Standard deviation	Deviation of the lower thickness size from the target value (mm)	Standard deviation
Black locust	Swaged	0,88	0,61	0,95	0,59
	Stellite tipped	0,89	0,63	1,17	1,3
	Recently developed	0,63	0,38	0,75	0,47
Poplar	Stellite tipped	1,13	0,72	1,25	0,76
	Recently developed	0,77	0,51	0,92	0,5

swaged teeth blade were out of the measurement range of the equipment ( $\pm 250 \mu\text{m}$ ). Consequently, lumbers sawed with swage-set teeth blades were not evaluated. The surfaces produced by the stellite coated blades were within measurable range thus, the performance of the new blade was compared to the surface quality produced by this blade configuration. Results indicated that the new blade can produce better surface quality. In terms of  $R_z$  values the improvements for oak, black locust, poplar and pine were 18%, 48%, 44% and 41%, respectively.

**Table 4** Calculated  $R_z$  values of surface roughness measurements

Sample	Oak	Black locust	Poplar	Pine
	$R_z$ Av. ( $\mu\text{m}$ )	$R_z$ Av. ( $\mu\text{m}$ )	$R_z$ Av ( $\mu\text{m}$ )	$R_z$ Av. ( $\mu\text{m}$ )
Stellite tipped band	175	105	181	205
New band	144	58	102	120

### Summary and Conclusions:

During the course of this study, we compared the performance of a recently developed saw band to the cutting quality of conventional, swaged-set and satellite-tipped saw bands. Our objective was to decide which tooth formation provides the best size accuracy and minimize the surface roughness. Based on the outcome of this investigation the following conclusions can be made:

- The new blade demonstrated the smallest drift. Compared to the other types of blades the decrease in drift was about 7-10% for hardwoods and 20-30% for softwoods.
- Results indicated that the blade configuration has no significant influence on the out-of-plane blade deviation.
- Size accuracy of the lumber was the best when cutting with the recently developed band blade. An average of 30% improvement was observed.
- Compared to the satellite tipped band, the new blade created 18% less rough surface on oak and almost 50% less rough surfaces on the other species.
- Based on the outcome this work, it can be stated that the recently developed saw band is considerably more accurate and produces better surface quality than that of conventional satellite tipped and swaged-set teeth tools.

### Acknowledgements

The authors wish to express their sincere appreciations to Havasi Lajos, chairman of A\_LAP Kft. who is the inventor of the blade and to Kardos József, chairman of Kardex Kft for their technical help in many ways. This project was sponsored by the National Institute of Research and Technology, Hungary under the Jedlik Anyos Tender entitled: "Development of model technologies for primary processing of qualitative round wood" within the project of FAFORRAS. The financial support is gratefully acknowledged.

### References

- [1] Magoss, E. (2006): Természetes faanyagok felületi érdessége. Egyetemi jegyzet. Nyugat-Magyarországi Egyetem, Sopron.
- [2] Boronkai, L. (2003): Faipari kézikönyv III. Faipari Tudományos Alapítvány, Sopron.
- [3] Grube, A. E. (1963): Faforgácsoló szerszámok. Műszaki Könyvkiadó, Budapest.
- [4] Magoss, E. (2002): Természetes faanyag felületi érdességének összefüggései I. rész: Elméleti áttekintés és vizsgálati módszerek. Faipar 50 (2): 27-29
- [5] Magoss, E. (2002): Természetes faanyag felületi érdességének összefüggései II. rész: Kísérleti eredmények és értékelésük. Faipar 50 (3): 8-11
- [6] Sitkei, Gy. (1994): A faipari műveltek elmélete. Mezőgazdasági Szaktudás Kiadó, Budapest.
- [7] Lugosi, A. (1973): Faforgácsoló szerszámokat karbantató gépek. Műszaki Könyvkiadó, Budapest.
- [8] Lugosi, A. - Bobok, L. - Erdélyi, Gy. (1963): Fűrészipari technológia. Műszaki Könyvkiadó, Budapest
- [9] Lugosi, A. (1974): Faipari kézikönyv. Műszaki Könyvkiadó, Budapest.
- [10] Hargitai, L. (1978): Keretfűrészlapok él tartósságának növelése stellit felhordással. Faipar. 313-316
- [11] Csiha, Cs. - Alpár, T. (2003): Nagyedényes fafajok felületi érdességének értékelése. Faipar 51 (1): 10-16

# UTILIZATION OF TERRESTRIAL HEAT FOR AIR-CONDITIONING OF RELAY STATIONS

László TÓTH – Norbert SCHREMPF – Lajos FOGARASI –  
Gábor BIHERCZ  
Szent István University, Faculty of Mechanical Engineering, Gödöllő

## Material and Methods

### Objective and tasks

The objective of the project was to develop a simple energy saving system and to adapt it to the relay stations.

Two versions have been preliminary elaborated:

- (A) Application of **shallow-well (ground loop) type (reversible) heat pumps** – from the soil layer at 5-to-10-m depth, adjacent to the containers  
(B) The other version – a design **without the compressor cycle**

It can be applied in actual practice if a shallow but sizable collector can be installed in the adjacent area to the construction of station of which surface area is suitably large to fulfil the 'heating' in winter or the 'cooling' functions, by the heat absorbed from the soil.

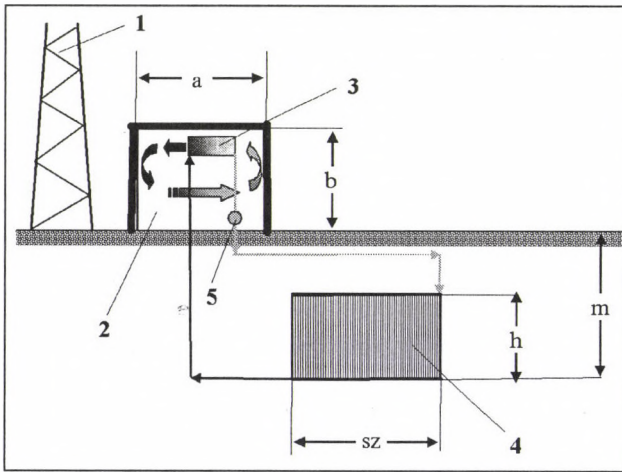

**Figure 1** Schematic diagram of the heat-exchanger type system  
1 – relay tower, 2 – container, 3 – fluid-air heat exchanger,  
4 – fluid-soil heat exchanger, 5 – circulating pump  
a – width of container, b – height of container,  
h – height of soil collector, sz – height of soil collector,  
m – bottommost point of collector in the soil

The version (B) is simpler since only a pump and a fan required for the circulation of fluid and air has to be installed in the system; they are controlled by the thermometers mounted in the control cabinet of the station.

The conception of this device can be seen in Figure 1.

### Theoretical fundamentals

The temperature of the air can be calculated by the follows equation:

$$t_{i_p} = t_{i_0} + \left( \int_{i=0}^{\tau} \frac{\dot{q}_e}{c_{p_i}(t_{i_p})} + \int_{i=0}^{\tau} \frac{\dot{q}_{kon}}{c_{p_i}(t_{i_p})} + \int_{i=0}^{\tau} \frac{\dot{q}_{hoccs}}{c_{p_i}(t_{i_p})} \right) [^{\circ}\text{C}] \quad (1a)$$

$\dot{q}_{hoccs}$  = heat load of the heat exchanger

$\dot{q}_{kon}$  = heat load of the container

The **heat load of the heat exchanger** can be calculated as follows:

$$\dot{q}_{hoccs} = \kappa_{hoccs} \cdot A_{hoccs} \cdot dt \quad (1b)$$

that is –

$$\dot{q}_{hoccs} = \frac{1}{\frac{1}{\alpha_1} + \frac{\delta_{cs\delta}}{\lambda_{cs\delta}} + \frac{1}{\alpha_2}} \cdot A_{hoccs} \cdot (t_i - t_{glikol}) \cdot 0,001 \text{ [kW]}$$

$A_{hoccs}$  = surface area of the heat exchanger

The above can be positive or negative according to that whether the air or the glycol is the warmer. So the heat exchanger operates as either a heating or a cooling panel.

Accordingly, the temperature of the air can be modelled by the equation (4a) in which the hour-second conversion factor is to be written and, after a further simplifying operation, it can be described in the following way:

$$t_{i_p} = t_{i_0} + 3600 \cdot \int_{i=0}^{\tau} \left[ \frac{1}{c_{p_i}(t_{i_p})} \cdot (\dot{q}_e + \dot{q}_{kon} + \dot{q}_{hoccs}) \right] \cdot d\tau \text{ [}^{\circ}\text{C}] \quad (2)$$

The similar principle to the air can be applied to the glycol. The enthalpy of the air is changed by two effects – on the one hand, the glycol delivers the heat transferred or absorbed by the air in the inner heat exchanger and, on the other hand, the glycol transfers or absorbs a certain quantity of heat in the heat exchanger in the soil.

For the change in temperature of the glycol can be written:

$$t_{glikol_p} = t_{glikol_0} + 3600 \cdot \int_{i=0}^{\tau} \left[ \frac{1}{c_{p_{glikol}}(t_{glikol_p})} \cdot (-\dot{q}_{kon} + \dot{q}_{tal}) \right] \cdot d\tau \text{ [}^{\circ}\text{C}] \quad (3a)$$

$q_{tal}$  = heat load of the soil

The addition of heat into the soil can be calculated by the equation –

$$\dot{q}_{tal} = c_{tal} \cdot A_{cs\delta\delta} \cdot \frac{1}{\sqrt{a_{tal} \cdot \tau_{ref} \cdot \pi}} dt \text{ [kW]} \quad (3b)$$

$A_{cs\delta\delta}$  = csővezeték felülete a kollektorban

ahol:

$$a_{tal} = \frac{\lambda_{tal}}{\rho_{tal} \cdot c_{tal}} \left[ \frac{m^2}{s} \right] \text{ és } \tau_{ref} = 180 \text{ [h].}$$

In addition, always there is a vertical heat flow ( $\dot{q}_{h\delta\delta}$ ) existing in the soil; its value is 0.2 W/m as an average in Hungary. This subsurface heat flow either increases or decreases the temperature of the actual soil layer in the way that the average soil temperature of 15 °C shall be permanent. Accordingly, the temperature of the soil can be determined in the following way:

$$t_{tal_p} = t_{tal_0} + 3600 \cdot \int_{i=0}^{\tau} \left[ \frac{1}{c_{p_{glikol}}(t_{glikol_p})} \cdot (\dot{q}_{tal} + \dot{q}_{h\delta\delta}) \right] \cdot d\tau \text{ [}^{\circ}\text{C}]$$

Design and installation

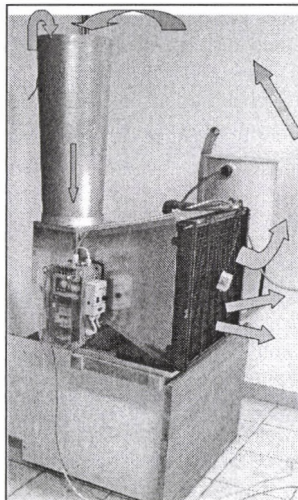

Figure 2 The designed and installed interior unit

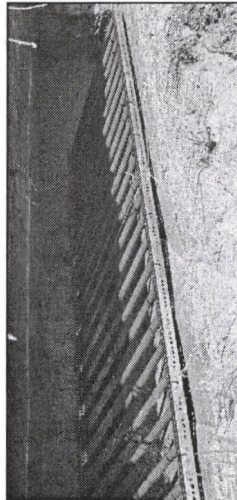

Figure 3 The collector in the soil

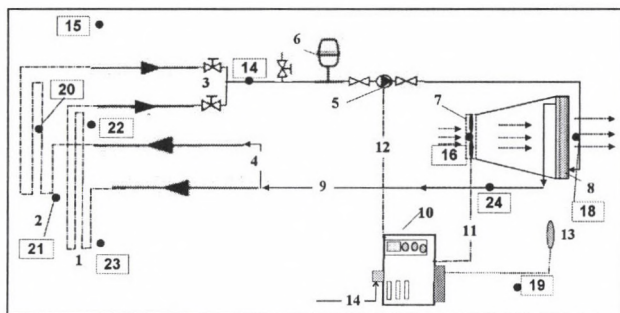

Figure 6 Schematic diagram of the system

1 and 2 – exterior collectors; 3 and 4 – shut-off cocks; 5 – fluid pump; 6 – compensator vessel; 7 – fan; 8 – water-air heat exchanger; 9 – return branch; 10 – control device; 11 – control of fan; 12 – control of pump; 13 – interior thermal sensor; 14 – power supply  
 Positions of the thermal sensors used during the measurements (bordered code numbers) 14 – temperature of inlet water; 15 – temperature of the exterior air (in shadow); 16 – inlet side of the air-water heat exchanger (tested with two versions – a heightened one and when the height was equal to the outlet opening); 18 – air temperature at the outlet of heat exchanger; 19 – interior or room temperature; 20 – ...; 21 – ...; 22 – ...; 23 – ... at 7-m depth; 24 – temperature of the return water after the heat exchanger

Results

At the bottom points of the collectors, the initial temperature was 18 to 19 °C. After moistening the temperature decreased to 17 °C; it proves the better heat conductivity of the wet soil and, at the same time, it is guiding principle for the installation.

At the top part of the collectors, the temperature was higher by 2.0 to 2.5 °C but this difference decreased to 1.5 to 2.0 °C in the warmer periods. Accordingly, it will be reasonable to decrease the height of collectors ('probes').

During the period before the start of operation, the temperature of the collectors decreased; the soil conducted the heat away from the ambience of the collector pipes. Then, after switching the system on, the temperature gradually increased – the difference grew to 0.2 to 0.4 °C in 2 to 3 hours – and the increase continued up to the end of running of the system. There were considerable differences between these trends according to the actual times of day – the change in the heat load or the temperature in the interior space.

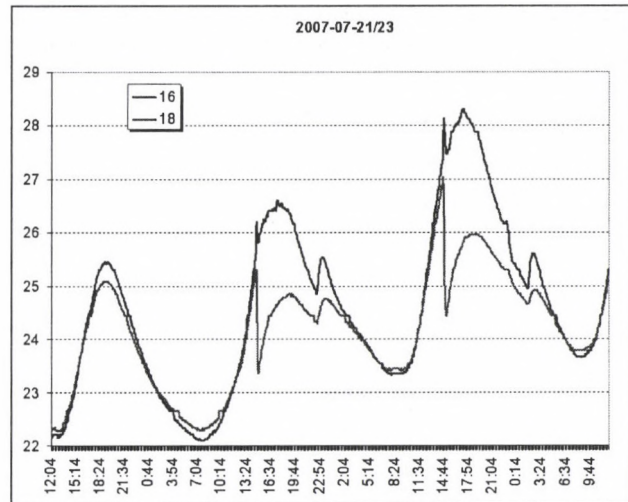

Figure 4 Temperature pattern of the inlet and outlet sides of the water-air heat exchanger

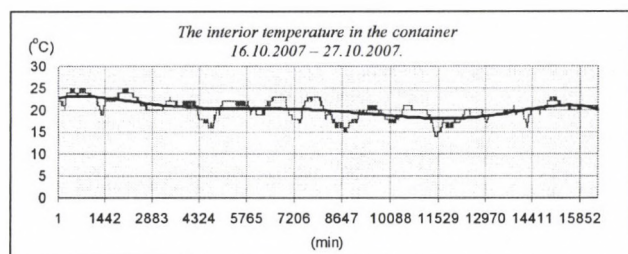

Figure 5 Course of the interior temperature in the container

The rotary speed of the fan adapted to the system was changed in 10 steps; however, only the upper 30 % of the available control range of air delivery was utilizable.

It can be established from the test series that the surface area of the collector and the characters of the interior heat exchangers were technically in a good accordance with each other. It is expected that the air-delivery performance of the fan of the air-water heat exchanger should be increased by one size-class by which an air delivery 180 to 200 m<sup>3</sup>/h can be achieved in comparison with the present value between 80 and 120 m<sup>3</sup>/h.

The delivery capacity of the pump can be changed in 3 stages; the short tests showed that the pump should be operated with the top speed (stage 3) when the pump delivery was 4 m<sup>3</sup>/h and the turbulence of the fluid flow was approximately four times greater than the required minimum value.

In cold nights (the exterior temperature decreased below 10 °C), it was managed to test the system in similar conditions to that in the cold season; in this case, the collector cooled the soil therefore the temperature of the soil layer was lower next day – it improved the efficiency.

Evaluation and suggestions

(1) It is reasonable to position the bottom points of the collectors to the depth 2.5 to 3.0 m and, instead of the collector height of 1.1 m, 0.5 to 0.6 m should be chosen; the length of the collector should be increased in the ratio to the reduction. It is advisable to fit collectors on both sidewalls of the dug trench in the soil accordingly two branches with opposite flow directions are placed in one trench which are connected in series to the collectors in the adjacent trench at a distance of at least 2 m. The pipes leading to the building (container) should be embedded in the bottom depth range of the collector; the heat loss or the absorption of heat can be reduced in this way. The design of the interior heat exchanger and the control unit has to be modified (Figure 10) – such as changing the heights of

the inlet and outlet points or placing a baffle before the outlet opening by which the air can be enforced to circulate inside the room; thereby the efficiency of heat transfer increases.

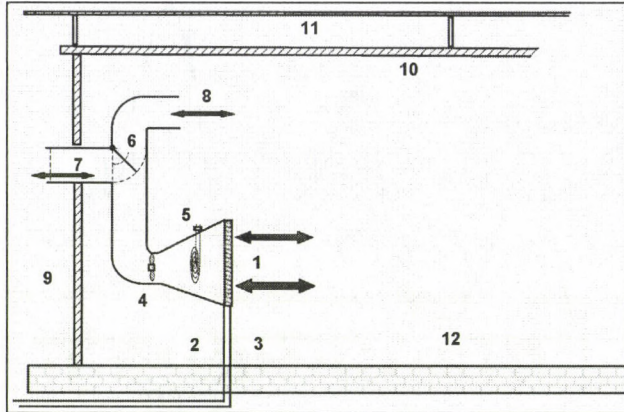

**Figure 6 The suggested construction design**  
 1 – air-water heat exchanger, 2 – inlet from the soil collector, 3 – outlet towards the soil collector, 4 – reversible fan of variable rotary speed, 5 – auxiliary heater, 6 – changeover air flap; 7 – inlet/outlet opening of external air, 8 – inlet/outlet opening of internal air, 9 – insulated side wall of the container, 10 – insulated ceiling of the container, 11 – shade from the sun

(2) The use of the system is absolutely economical; it saves a certain amount of electric energy and, at the same time, frees a capacity as well; due to the reduction, the actual container and the relay station can be equipped with further instruments – the function can be improved without increasing the contingent capacity supplied by the mains (and its considerable cost also can be saved).

(3) Due to the lower energy consumption, the device is ecologically beneficial since an emission of CO<sub>2</sub> of 7500 kg/year can be avoided by its application.

#### References

- [1] Thorhallsson, S. - Ragnarsson, A. (1992): What is geothermal steam. *Geothermics*, 21. k. 5/6.sz. okt./dec. p. 901-915
- [2] Hunyár M. - Schmidt I. - Veszprémi K. - Vincze Gy-né (2001): A megújuló és környezetbarát energetika villamos gépei és szabályozásuk (*Electric machinery of the renewable and environment protecting energetics*). (339 o.) Műegyetemi Kiadó, Budapest. ISBN 963 420 670 0
- [3] [www.regale.hu/klima/site.php?inc=kezdo](http://www.regale.hu/klima/site.php?inc=kezdo)
- [4] [www.cres.gr/kape/links\\_energy\\_uk.htm](http://www.cres.gr/kape/links_energy_uk.htm)
- [5] [www.heatpumpcentre.org](http://www.heatpumpcentre.org)
- [6] [www.klima.kvvm.hu/index.php?id=36](http://www.klima.kvvm.hu/index.php?id=36)

# COMPUTER AIDED MODELLING OF WIND FARMS (ENERGY PRODUCTION)

László TÓTH - Norbert SCHREMPF - Annamária KONCZ  
Szent István University, Faculty of Mechanical Engineering, Gödöllő

## Introduction

In the planning process of wind farms the volume of expected electrical energy production is the most important technological feature to determine. The stream modifying effects of terrain have an impact on the amount of produced energy in a mountainous area. The calculations are based on expedition wind speed and wind direction measurements recorded at two or three heights. Mainly this is the reason why the modelling process is needed for determining the optimal site and lay-out of an actual wind farm. Nowadays there are two types of model calculations spread. Whilst the WindPro application uses a simplified terrain model, the WASP (Wind Atlas Analysis and Application Program) application uses a complex stream model. These two modelling processes were compared under special boundary conditions (configuration of terrain, surface friction, wind farm siting).

## Material and method

The WASP (Wind Atlas Analysis and Application Program) program is a linear and spectral model designed for the horizontal-and vertical extrapolation of wind data statistics. In Figure 1, three different sub-models of the WASP can be seen. The first is the Orographic flow sub-model which contains surface elements, the second is the Roughness sub-model which contains surface roughness and the third is the Shelter sub-model which contains sheltering obstacles. The input data are the measured values of wind data and the output data are the wind climate data of the actual area. With the help of wind map statistics, the wind fields can be determined at all points of the given area.

### The Orographic flow sub-model

The relative speed change with the Orographic flow model is:

$$\Delta S = \frac{u_2(\Delta z_2) - u_1(\Delta z_1)}{u_1(\Delta z_1)} [\%]$$

$u_1$  = undisturbed wind speed,  
 $u_2$  = modified wind speed,  
 $\Delta z$  = height above terrain.

### The Shelter sub-model

Wind changes near to different objects as buildings and landmarks.

In the case of a bidimensional surface, the following function can be defined (Perera, 1981):

$$\frac{\Delta u(z_a)}{u(z_a)} = 9,75 \left( \frac{h}{z_a} \right)^n \frac{h}{x} (1-P)\eta \exp(-0,67\eta^{1,5})$$

$$\eta = \frac{z_a}{h} \left( \frac{0,32}{\ln(h/z_0)} \cdot \frac{x}{h} \right)^{\frac{1}{n+2}}$$

### The Roughness sub-model

The wind profile can be approached with three different logarithmic parts according to experiments (Rao et al., 1974; Semperiva et al., 1990).

$$\text{if } c_1 h \leq z \quad u(z) = u' \frac{\ln(z/z_{01})}{\ln(c_1 h/z_{01})}$$

$$\text{if } c_2 \leq z \leq c_1 h \quad u(z) = u'' + (u' - u'') \frac{\ln(z/c_2 h)}{\ln(c_1/c_2)}$$

$$\text{if } c_2 h \leq z \quad u(z) = u'' \frac{\ln(z/z_{02})}{\ln(c_2 h/z_{02})}$$

$$\text{where: } u' = (u_{*1} / \kappa) \ln(c_1 h / z_{01})$$

$$u'' = (u_{*2} / \kappa) \ln(c_2 h / z_{02})$$

$$c_1 = \frac{1}{3}, \quad c_2 = \frac{1}{15}$$

With repeated applications of the formulae, even complex surfaces can be modelled but only with 10 roughness-changes per an area.

## The examined area and the method of examination

### The modelled area:

The examined area is on the boundary of Central and North Hungary in Pest and Heves County. The wind measurements happened on three sites.

1<sup>st</sup> measurement point: energetic wind measurements

2<sup>nd</sup> measurement point: SODAR (Sonic Detecting and Ranging system) measurement OMSz (Országos Meteorológiai Szolgálat, National Meteorological Service)

3<sup>rd</sup> measurement point: OMSz (National Meteorological Service) measurement station

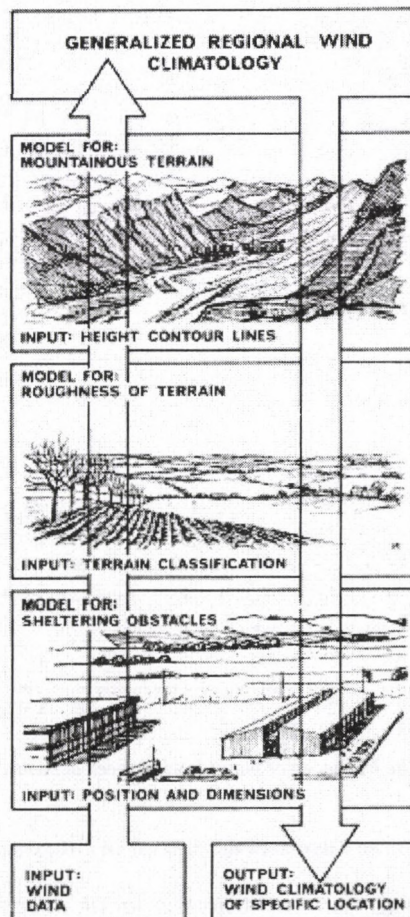

Figure 1 The models of WASP

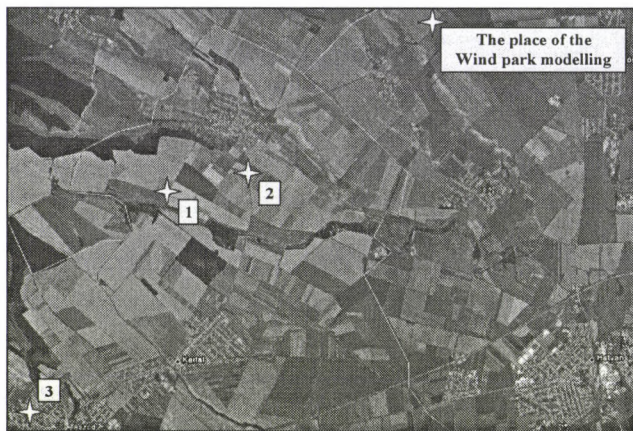

Figure 2 The site of measurements and wind farm planning

### Analysis of measured data

#### The meteorological and the energetic wind measurements

In the first step the following data of the OMSz database and the tower measurements (60 meters) were compared: monthly mean wind speed (Figure 3), directional distribution of wind speed (Figure 4) and wind speed frequency (Figure 5). The comparison of data show that the two databases recorded on different locations observed alike changes of wind speed and direction.

The variation of monthly data shows also the same dynamics of systems. According to these results, the precision wind measurements (which are considered as expedition wind measurements due to their duration) can be compared with the long-term meteorological database. Strong similarity can be seen in the directional wind speed values. The biggest values of wind speed were observed in both cases from the direction of West North-west.

In further analysis, the frequency of wind direction is an important feature because an advantageous case is when the strongest wind comes from the more frequent wind direction (Figure 4.). According to the analysis of wind direction data the direction of wind is approximately the same on the two measurement locations. Considerable differences can be seen in the sector of the North and West direction where the data of tower measurements show bigger deviations than the data of the meteorological station (Figure 4.).

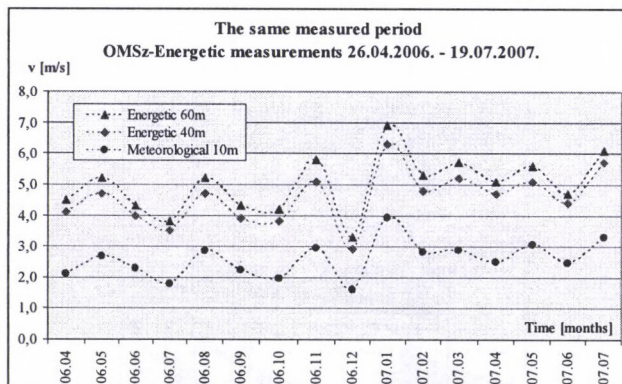

Figure 3 The frequency of monthly wind speed at measured at 10, 40, and 60 meters

There may be two reasons of the directional differences of wind speed:

- the changing wind conditions due to the different terrain conditions of the distant measurement points (approx. 6,5 kilometres),

- the influence of stream modifying and shelter effects (vegetation and buildings) of surrounding elements on the sensor of the meteorological stations.

The determination of the Hellmann factor (height-correction factor) is an important purpose of the analysis of energetic wind measurements. In Figure 4, a similar tendency of curves measured data at 60 and 40 metres can be seen, of course, with different number pairs by directions. Accordingly, it is expedient to compute the values of the Hellmann factor in a breakdown by wind directions, and to average the values by the frequencies of wind direction. The directionally determined Hellmann-factors were compared with the data observed by the SODAR system.

The directionally determined Hellmann-factors were compared with the data observed by the SODAR system.

The same measurement height of 60 meters happened to be a favourable condition for the comparison of the tower and SODAR measurements. The two measurement systems worked almost simultaneously but the SODAR system measured lower wind-speed values.

The mean deviation is  $0.6 \pm 0.7$  m/s. This is not inconsistent with the working experiences with SODAR, because it is extremely sensible to the different sound effects. However, this mean deviation is not acceptable. The anemometers used at the tower measurements were tested in internationally accepted laboratories in accredited wind tunnels. Accordingly, the tower measurement database is considered to be as the basis.

Contrarily to the significant deviations in the mean wind speed values, the direction measurement of wind was the same in both months, independently of the measuring system.

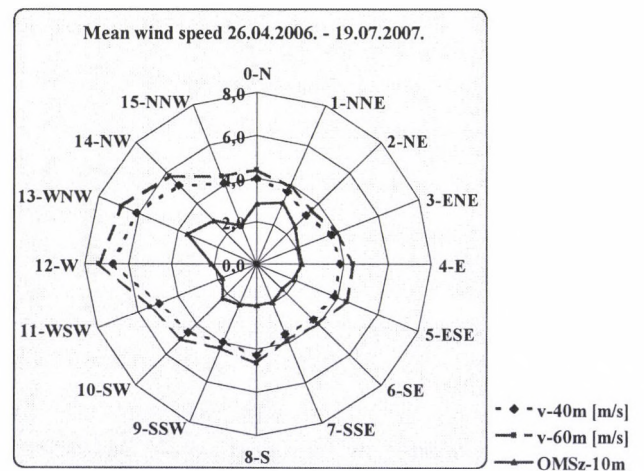

Figure 4 Wind speed values (measured at 10, 40 and 60 meters) by directions (in the measurement period between 22.04.2006 and 19.07.2007)

#### Determination of the expected power production

One of the most important features of wind farm siting is the expected electric energy production. The economic efficiency indices cannot be calculated without the value of expected electric energy production.

The value of produced electric energy is influenced by –

- the wind profile of the given area,
- the fronts passing through the given area,
- the technical parameters of the given wind power plant.

In the modelled case the actual wind power plant produced 4800 MWh electricity in the measurement period. This means 27-% capacity factor which is definitely a good result in

Hungary. Of course, this is a theoretical result which should be corrected and specified at the planning of wind farms.

## Results

### The energy production calculation of wind farms

During the planning process, 5 wind power plants were erected and the effect of surface elements and the park effect (the stream shelter effect of wind power plants and the effect of turbulence) were considered as well.

The expected power production of the wind farm is 23,400 MWh. Because of anomalies in weather, 10 % of power production had been subtracted from the expected power production. The expected power production changes because of the subtraction and it is expected to be 21,000 MWh which results in 24 % capacity factor for 'an average' power station.

The distance between the location of measurements and the place of siting raised the question of the similarity or difference of the two locations. This examination was carried out with the WAsP software.

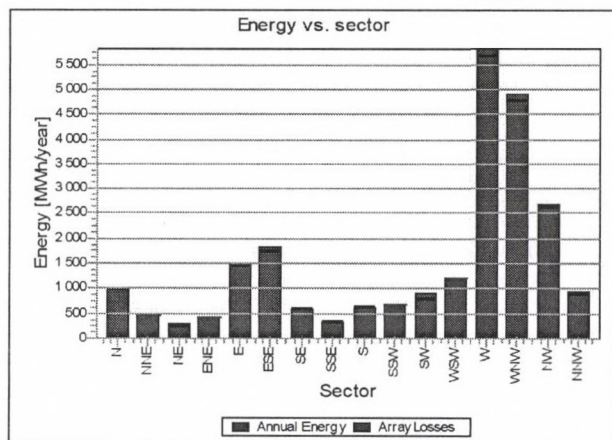

Figure 5 Energy production in the wind farm and losses of production due to the park effect (WindPRO)

### Energy production calculation with WAsP

With WAsP, several parameters were determined.

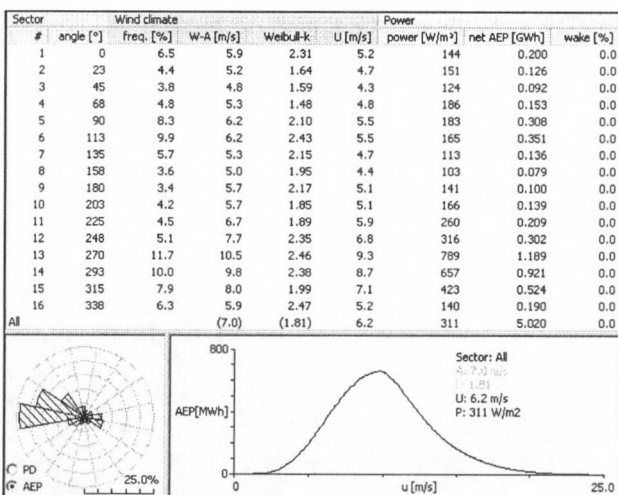

Figure 6: The determination of power production of a wind power plant with WAsP

The most important features are as follows: the specific wind power at 138 meters height above terrain ( $W/m^2$ ), the mean wind speed (m/s), the annual expected power production [GWh] and the Weibull-parameters (A, k).

The calculations of WAsP are based on the 60-meter data of tower measurement. The maps calculated by WAsP show big territorial overlook consequently the examined parameters cannot be seen in details as wished; however, the numerical results can be followed well (Figure 6, Column 8, net AEP [GWh]).

## Conclusions

In the modelling process of wind farms, terrain has an essential impact on the range of expected electric energy production. In the examined case, a slightly structured area of Hungary had been selected which is a transition between the plain and the hilly surfaces. The planned wind farm was modelled with two methods. One of the methods uses the effects of simple digital terrain mapping while the other – more complicated mathematical functions closely connected each with other. During the examinations it was advantageous that the databases overlap in time on the three locations. One of these measurements was a long-term measurement database. With the help of this database, the reliability of the prognosis increased. During the calculations the losses due to the park effect can be easily observed. The main source of losses in energy production is the effect of turbines which subtracts energy from the stream and decreases its energy content. In the case of siting wind farms, every wind tower affects each other.

In these cases, we should already speak about a park effect rather than the turbine effect. With the comparison of the applied modelling processes, it is seen that the energy production values calculated by WAsP are a little larger but, in the WAsP calculations, the park effect was not taken into consideration. With both methods nearly the same results were gathered with the given conditions. With the usage of the applied methods it came to light that at slightly structured surfaces WindPro provides appropriate results for energy production calculation. WAsP is basically applicable for significantly structured terrain for large surfaces, even for 25 km<sup>2</sup>. Therefore further investigation of the application of modelling processes is required, with an increased terrain structure and testing area.

## References

- [1] Nielsen, P. (2006): WindPro, Chapter 3 - Energy, EMD International A/S, 135-204p.
- [2] Mortensen N. G., Heathfield D. N., Myllerup L., Landberg L., Rathmann O. (2007): WAsP 9, Risø National Laboratory
- [3] Perera, M. D. (1981): Shelter behind two-dimensional solid and porous fences. Journal of Wind Engineering and Industrial Aerodynamics 8, p. 93-104
- [4] Rao, K. S. Wyngaard, J. C. and Coté, O. R. (1974): The structure of the two-dimensional internal boundary layer over a sudden change of surface roughness, Journal of Atmospheric Sciences 31, p. 738-746
- [5] Sembery P. - Tóth L. (2003): Hagymányos és megújuló energiaforrások, Szaktudás Kiadó, Budapest, 352-360p., p. 390-392
- [6] Semperiva A. M., Larsen S. E., Mortensen N. G. and Troen, I. (1990): Response of neutral Boundary layers to change of roughness. Boundary-Layer Meteorology 50, p. 205-225

## TECHNICAL CONDITIONS OF ENERGY-CANE GROWING (Development Trends)

László BENSE - Zsolt SZÜLE - Lajos FOGARASI  
Szent István University, Faculty of Mechanical Engineering, Gödöllő

### Introduction

According to the Kyoto Protocol (the international Framework Convention on Climate Change), Europe attempts to decrease the carbon-dioxide emission, and, at the same time, make the member countries independent from the dwindling energy carriers imported mainly from beyond the borders. The EU intends to achieve this objective by increasing the utilization of the renewable energy sources. The members are bound to raise the ratio of the renewable energies by two documents as well; the one (the White Book) concerns the aggregate energy output and the other (directive No. 2001/77/EC) – the electric energy production.

Hungary is capable of increasing the ratio of renewable sources mainly in the fields of the solar, geothermal, wind and biomass-base energies. Since the other renewable capacities are limited in Hungary, the readiest renewable source is the biomass for energetic use.

The energetic utilization of the biomass can be sorted into three large fields: utilization of solid biomass directly for heat production, manufacturing of liquid energy agents (alcohol, vegetable oil as bio-diesel oil) and generation of gas (biogas).

Firing in boilers or other caloric devices (direct heat production) is the cheapest process of the utilization of biomass as energy. Amongst other appropriate materials of biological origin for production of heat (forest and woodworking products and wastes, fuels from woody energy plantations as acacia, poplar and willow, natural cane or reed, different herb-form energy-plantation products and field-land by-products, horticultural wastes etc., the grown energy cane (actually *Miscanthus*) domesticated by plant-breeding as an appropriate and acceptable energy plant is recommended.

### Preparatory works of planting *Miscanthus*

*Miscanthus Sinensys Giganteus* is a perennial endemic plant in East-Asia but it can be successfully grown in the most regions of Europe. The applied technologic machinery is similar to that of the corn-production or rather – the Sudan-grass culture. It determines the way of tith preparation that the plant is perennial, and is to be planted in the spring. A plantation may subsist even for 20 years and after it has established the soil cannot be cultivated at all; accordingly, it is expedient to apply deep tillage operations (sub-soiling and deep-ploughing) before planting. After planting in the first two years weed killing by inter-row cultivators might be necessary. The only possibility of ventilating the soil is the rhizome harvest when a certain part of rhizomes is cut and picked up from the established *Miscanthus* stand for transplanting; in other cases, the soil state is conserved by the regeneration of rootage and the soil protecting effect of the fall of leaves. The treading soil-damage can be prevented by the harvest on the frozen ground in winter.

All the farms have got the necessary tillage equipment (subsoiler, plough, disc-harrow, field and inter-row cultivators, seed-bed preparing combination, ring- or clod-breaker rollers). Before planting the energy cane, as with all perennial cultures, farmyard dung manure is expedient to use for fertilization. The nutrient demand of *Miscanthus* is slight but a regular annual fertilizer application will be recovered. Spreading sewage-water or other organic sludge matters (e.g. slurry) can be substituted for artificial fertilizers since the *Miscanthus* is not used for food or foodstuff.

At present there are no known pests or pathogens of *Miscanthus* in Hungary therefore, besides the application of a total-effective

herbicide before planting, spraying may be necessary only against the diphyllous weeds but only in the first two years. The established plantation keeps down the weeds. The spraying has to be carried out after that the weeds appeared but before the one-metre height of the cane. The plant recovers from the damage of treading; accordingly, the use of field sprayers with spraying boom is allowed in this culture.

The bottle-neck in the growing technology is the planting process and the harvest. These operations can be performed by the regular agricultural machines and implements as well; however, there are several problems with their operation in the *Miscanthus* technology.

### Planting

The *Miscanthus* can be planted by transplanting seedlings (plants) or rhizomes. The planting depth is about 10 cm with rhizomes and the stand density is 1 to 4 plants per square metre with both methods. The higher plant density is usually reasonable when the main goal of growing is only to produce propagation material. After the rhizome harvest (digging and picking-up) enough rhizomes remain in the soil; the soil will be soon overgrown again with *Miscanthus*.

When growing directly cane for sale the stand density is 1 to 2 plants per square metre; the actual row space is 0.75 to 1 m and the space between plants in a row is 0.5 to 1 m.

Theoretically, any transplanter is suitable for planting *Miscanthus* seedlings however the supply with plants is problematical – the available seedlings are quite unequal which limits the mechanizing of the operation. Generally, with free-root plants, the length of 25 to 30 cm is advantageous or, with plants in soil blocks, the block size of 4.5×4.5 cm is suitable for planters.

Rhizomes can be transplanted by potato planters as well. Unfortunately, due to the tangled, meshing root-cuttings, the wholesale-manufactured and widely used scoop planters are not really usable as the scooping process of rhizomes from the seed-hopper is not definitive. The auto-manual (revolver-type) designs can be successfully used but jams may occur when dropping pieces out of the feed block if the rhizomes are longer than 10 cm or they are twiggy.

The full-automatic designs are preferred by the industrial farms. The *Hvidsted Energy Forest Co.* in Denmark developed a special *Miscanthus*-rhizome planter (Figure 1). The machine plants a (fifty-fifty) rhizome-soil mixture. A scraper conveyer delivers the planting mixture over the plateau of 5-metric-tonne capacity to the front of the machine (actually – a manure spreader) where a horizontal master drum and the vertical beater (shredder) rotors throw the rhizomes into the collecting cones. The cones are vibrated in order to prevent jams. The row space is 75 cm and the planting depth can be adjusted between 2 and 20 cm. The plant spacing depends on the ratio of scraper-conveyer velocity to the travel speed. The rows are covered by rubber press-rollers loaded by a 150-kg mass in order to achieve the good soil-rhizome contact.

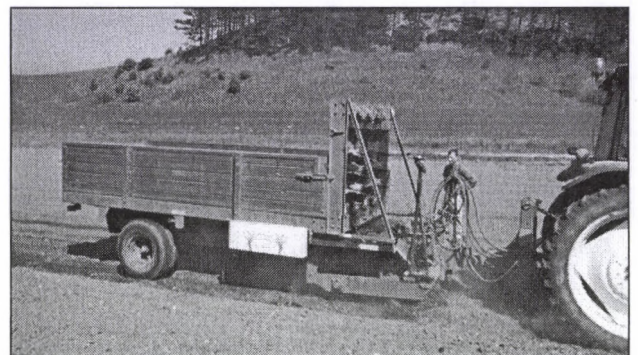

Figure 1 Rhizome planter NORDIC (Hvidsted Energy Forest)

The area-performance of the NORDIC type is high, and requires minimal manual work. However, the distribution of plant number is unequal; this machine is **used mainly in rhizome production** – with a stand density of 20,000 or even more plants per hectare.

**Rhizome harvest:** After disking or digging by a rotary tiller, the small quantity of rhizomes is picked up by hand. This manual pre-picking and cleaning is the real advantage of the process; the final product is marketable, ready-to-plant rhizome. Potato harvesters are suitable for picking up the rhizomes in quantity. For a short time the rhizomes **can be stored** even in clamps covered by damp earth. In cold-storage houses, the rhizomes mixed in moistened sand can be sustained even for several months; however, in this case, the post-picking – selection of the unviable pieces – is unavoidable.

The working principle of the special *Miscanthus* planter of the company BICAL is similar to that of the NORDIC but a rubber-coated belt conveyer is substituted for the scraper one. Its row space is 1 m, planting depth – 10 cm, performance – 10 ha per shift; however, the adjustment of the machine is complicated.

### Harvest of *Miscanthus*

Theoretically, the harvest of *Miscanthus* is already engineered; the roughage-harvester machine lines can be used in herb-like energy plantations.

The *Miscanthus* can be gathered by the usual (one-pass, self-propelled) forage chopper-harvesters as well. However, the dry-matter mass of one cubic metre of the energy-cane chops in bulk is only 80 kg; the efficiency of its space filling is extremely bad. Moreover, it is expedient to store the cut energy cane in a closed bunker protecting the material from the weather effects (rain, snow and wind). The storage space has to be ventilated for fear the bulk should heat.

The machinery line of haymaking is suitable for the harvest of *Miscanthus* as well; however, the harvest season (late winter or early in spring) is not good to the field drying and handling in windrows due to the stiff and hard canes. The conventional double-knife mowers are not suitable due to similar causes. The rotary mower is capable of laying down the cut stand in a narrow windrow required by the pick-ups only if the high canes are tilted forward by a purpose-made auxiliary frame before (and during) cutting. Accordingly, the use of **row-independent rotary mowers with counter-blades** (e.g. type Kemper) is suggested.

For gathering *Miscanthus*, the rectangular as well as the roll balers are suitable. By materials-handling aspects, the power stations prefer the **rectangular (square) big bales of high density** but the small municipal incinerator plants are capable of utilizing small bales as well. The density as well as the space filling efficiency of the bales is especially important value in the transportation and storage – the rectangular big bales are better than the round bales from both points of view. With a moisture content of 20 to 25 %, the bale density is 120 to 150 kg/m<sup>3</sup> with round bales, and 170 to 220 kg/m<sup>3</sup> with rectangular bales. The higher densities can be achieved by slicer-balers. **In Hungary, the harvesting moisture content of the *Miscanthus* is 7 to 10 %!** The primary objective is to make bales with the possible highest density – actually with the highest energy content per bale.

According to the tests carried out by the CLAAS Company between 1990 and 1995, the conventional pick-up device of the baler does not work properly due to the extreme features of the canes (length and springiness); the picking-up is problematical (either much material is missed or the device mixes earth in the bales). After a long experiment they found the suitable answer for the problem – the **direct baler**. The company made only a single test-machine but, after the CLAAS improvement, the firm Deutz-Fahr started to produce his self-propelled baler type Power Press 120H in series (Figure 2).

The tractor-implement combination shown in Figure 3 was designed by the Austrian firm HUMER. The main parts of the machine combination are the row-independent mower unit mounted on the front hitch of a 150-kW agricultural tractor, the under-mounted belt conveyer and a high-density baler (type Krone HDP Big Pack). The performance of this machine combination is 0.7 to 0.8 ha per productive hour and, supposing an average yield of 10 t/ha, 15 to 16 bales of 500 kg can be made in an hour.

For increasing the density of biomass-fuels (and, accordingly, decreasing the storage-space demand), a suitable process can be the pelleting as well. The firm Haimer at Igenhausen in Germany exhibited the prototype of the one-stage self-propelled chopper-pelleting machine (Biotruck 2000). The design does not seem a prospective solution for its energy requirement is significantly higher than that of other technologies.



Figure 2 A self-propelled baler (Deutz-Fahr)

In a similar way, it would be easy to design a special *Miscanthus* harvesting machine after the provisional but not manufactured harvester type Field Shuttle of CLAAS Co. The Field Shuttle is a self-propelled forage harvester-chopper type Jaguar which is equipped with a chassis frame suitable for carrying an articulated trailer or a chaff-collecting box. If a high-density baler type Quadrant (made by the same manufacturer of the base-machine) is mounted on the chassis, the result would be such a single-purpose machine which is capable of performing even the double of the conventional bale-density. Unfortunately, the price of this custom-built machine would be the twice of that of the basic forage harvester – 400,000 EUR!



Figure 3 A purpose-made machine combination (HUMER)

### Conclusions

The agricultural machines and implements used in the conventional plant growing technologies in Hungary are suitable for the mechanization of the production of *Miscanthus Sinensys Giganteus*. However, there is a special problem – the process of planting and harvest. Taking the conditions of Hungary into consideration, it is expedient to develop a new

rhizome planter – similar to the manually fed, revolver-type, mechanically spacing potato planting machines – and which requires less concentration of the operators. So an operator can feed more cells at the same time and the mechanism facilitates to avoid the deviation (lag) from the planting rhythm.

Alike, the common forage-harvest machine lines are suitable for the Miscanthus technology; however, storage difficulties will be arise when using chopper-harvesters and contrary, the conventional baling process will be accompanied with pollution – mixing of soil (snow) in the bales. A single-pass, self-propelled harvester-baler would be the best solution but such machines are not manufactured at present. Custom-made machines might be ordered; however, it has to be reasoned even if the production volume is quite large.

*A research supported by the projects OTKA-NKTH K 68103 and BLOWATT*

#### References

- [1] Barótfi I: Energiafelhasználói kézikönyv (Handbook for Energy Users). Környezet-technikai Szolgáltató Kft., Budapest, 1993.

- [2] Fogarassy Cs: Energianövények a szántóföldön (Field Energy Plants). SZIE Európai Tanulmányok Központja, Gödöllő, 2001. ISBN 963 9256 47 1
- [3] Miscanthus Practical Aspects of Bio-fuel Development. ETSU B/W2/00618/REP URN 03/1568. Energy Power Resources Ltd. 2003.
- [4] P. Venturi, W. Huisman, and J.Molenaar. 1998. Mechanization and Costs of Primary Production Chains for *Miscanthus x giganteus* in the Netherlands. *Journal of Agricultural Engineering Research* 69:209-215.
- [5] P. Venturi, W. Huisman: Harvesting of Non-Food Crops for Fibre Use. Wageningen.
- [6] Planting and Growing Miscanthus. Defra's Energy Crops Scheme, 2007.  
<http://www.defra.gov.uk/erdp/regions/default.htm>
- [7] Ueli Zweifel: Rund- und Quaderballen-presen (Round and Square-Bale Presses). Sweizer Landtechnik, 2007 juni/juli.
- [8] [www.bical.co.uk](http://www.bical.co.uk)
- [9] [www.championdenmark.dk](http://www.championdenmark.dk)
- [10] [www.claas.de](http://www.claas.de)
- [11] [www.humer-heiligenberg.at](http://www.humer-heiligenberg.at)

## CAST POLYAMIDE 6 POLYMER COMPOSITES FOR AGRICULTURAL MACHINE APPLICATIONS

Mátyás ANDÓ<sup>1</sup> - Gábor KALÁCSKA<sup>1</sup> - Tibor CZIGÁNY<sup>2</sup>

<sup>1</sup>Szent István University, Institute for Mechanical Engineering Technology, Gödöllő

<sup>2</sup>Budapest University of Technology and Economics, Department of Polymer Engineering, Budapest

### Introduction

In the agricultural applications of structural materials show some typical environment for machine elements. Very often improved abrasion resistance is needed due to high dust content of the surroundings. In slideways and transport systems of crops and grains the antistatic surface is important to avoid static charge and explosion. Further step is when the antistatic behaviour is not enough and fire-retardant or fire-safe polymer is required. Finally we decided to develop some new composite versions of magnesium catalytic cast polyamide 6:

- improved tribology grade having abrasion resistance
- antistatic composite version
- improved fire-resistant version

The magnesium catalytic cast polyamide 6 has a traditional production process in Hungary, so we could launch the research project on the basis of the present chemical plant and laboratory. The new chemical processes for the targeted composites were developed by the industrial partner, Quattroplast Ltd.

### Additives

The following materials are generally used for improvement of the tribology properties: graphite, silicon dioxide, polytetrafluoro-ethylene, polyethylene, molybdenum disulfide, lead, oils, mineral oils, phosphates, calcium silicate (calcium metasilicate), waxes, metal powders, silicone [6]. Polyamides have a very low friction coefficient when applied with lubricants, just even better than PTFE (the well-known name of which is Teflon). Under dry conditions, when during sliding and sticking, strong surface adhesion may be manifest, the value of the friction coefficient can be really high. In order to ensure operating safety, additives are necessary which reduce the friction coefficient under dry circumstances, as well. Molybdenum disulfide (MoS<sub>2</sub>), and PTFE has long been used as such an additive in plastic industry. Graphite and MoS<sub>2</sub> are solid lubricants the use of which reduces solidity and resistance [4, 13, 16].

In the plastic industry, numerous additives are used for increasing the electron-conducting capability of the base matrix. Antistatic characteristics are present when the surface resistance is under 10<sup>12</sup> Ω. Such materials are [6] pitch, graphite, carbon filaments, powders and conductive flakes, disks, filament, metal coated graphite and glass filament, metal coated glass beads. If these materials are used, the change of properties is only achieved if the concentration of the additive is higher than a certain value, because in this case, they can form a secondary, continuous conducting structure in the material. Another method of avoiding charging is the use of an antistatic material [3]. The additive is mixed to the base matrix in this case, as well, which provides long-term protection against electrostatic charge, but the polymer will not become conducting. Various graphite powders can be used relatively easily and successfully, but even these additives worsen mechanic properties [8, 11]. Among carbon derivatives, foam graphite, pitch and carbon nanotubes are also used [7, 12]. The latter is also distributed in a master mixture for a targeted area of use [10].

Increasing the burn resistance of plastics is a fundamental goal for which the following additives are widely used [9]:

chromium compounds, brominated compounds, materials containing crystal water, aluminum hydroxide, magnesium hydroxide, materials forming a coke-like foamy layer. Due to the phase-out of halogenic compounds, more and more new additives are emerging on the market. One such new material of combustion resistance is montmorillonite, as a result of which, heat formation at combustion undergoes a significant change.

It is apparent that as a result of montmorillonite, the intensity of combustion is significantly reduced and combustion itself is prolonged over time. Another important property from the aspect of combustion is that it prevents dripping, which reduces significantly the chance of spreading of the fire [2, 5, 15]. Moreover, montmorillonite significantly reduces the expansion of composite even more than on order of magnitude in comparison with the base materials [1]. Apart from montmorillonite, other additives can also be used for the prevention of combustion, which further reduce the intensity of combustion.

The structure of carbon nanotubes is highly characteristic, it is a graphite layer with the thickness of a single atom, rolled to a perfect cylinder.

One problem is posed by the fact that carbon nanotubes have a high tendency for aggregation, thus in the polymer base matrix, they are embedded in groups as a result of which, their excellent mechanical properties are not manifest, and they also form locations that accumulated tension. Thus, for this additive, the problem of distribution is increasingly present.

### Examination of Mechanical properties

After performing the first casting series, more than 100 different samples were available to us. As a first step of selection, a significant part of the samples could be excluded because those precipitations were also visible to the naked eye which showed the lack of success of additive building. We performed the following tests on the remaining 52 sample types: tensile test, Charpy impact test, tribology tests, electric tests.

From the aspect of material development, it is important to be able to select those samples among the many types of additive buildings with which it is worth continuing the process. Basic evaluation will be performed according to mechanical properties because due to this fact, we will be able to concentrate on additives, which do not significantly deteriorate the properties of our generally accepted technical plastic, but is capable of improving some special properties. Thus, promising samples can be selected according to the following considerations: samples with the greatest tensile strength; samples with the greatest elongation at break; samples with the greatest impact strength; samples with proportionately good mechanical properties.

By testing the first three categories, those additives can be mainly identified which increase the special mechanical property on the basis we are making our selection. However, this method cannot be used in our case, because the objective is to preserve the generally good mechanical property of the base material. The tensile strength of plastics can be smaller than metals by one order of magnitude, but their elongation at break can be greater by even two orders of magnitude than the value characteristics of metals. Under such proportion, it is furthermore characteristic of plastics that in the case of a small increase of their tensile strength, their elongation is significantly reduced but even a significant change of the specific impact strength causes a significant change of the other mechanical properties. The imbalance between traditional proportions would prevent universal usability in particular.

The mechanical properties of the natural base material (without additives) are targeted for further development (tensile strength: 79 MPa, elongation at break: 26%, impact strength (Charpy): 4870 J/m<sup>2</sup>). For the evaluation of mechanical properties, we have used specific numbers, which mean the following: we

divided the measurement results of experimental samples by the respective property of the base sample (e. g. the tensile strength of a sample is 83 MPa, the specific tensile strength is 105%, because  $83/79 \approx 1,05$ ). We have included the calculated specific tensile strength specific elongation at break and specific impact strength values in a decreasing order in tables, and above a designated limit, we assessed the samples as good. Testing and ordering individual specific mechanical properties will not bring any usable result because some prominent values are accompanied by a significant reduction of the other properties. Thus, we have introduced specific multiplication, which represents the product of specific values (for example, a sample has the specific tensile strength of 105%, the specific breaking expansion is 50% and the specific impact strength is 152%, in this case, the value of the specific product is 80%). Using this value, we can characterize the experimental materials from all of their mechanical properties. All in all, we could select by testing mechanical properties 5 samples out of the 52, for which mechanical properties are generally favorable and therefore, they can be used in everyday practice in many locations along with having other special properties.

### Examination of tribological properties

A second part of the elaborated selection method is that the samples are selected according to their special properties. In order to present this, we have used the direction of improving tribology properties. On the basis of the results of tribology properties, we are familiar with the characteristic value of friction coefficients in the sample, as well as wear and friction heat generation. Our primary goal in the case of this direction of material development is to reduce the value of the friction coefficient and not to spoil the wear resistance in a forced run (without lubrication). Therefore, we primarily took into account this factor upon selection. For tribotesting we applied pin-on-disc laboratory measurements. The method and the typical obtained curves are published more times elsewhere [14, 17]. For the purpose of better operability, we also worked with a specific friction coefficient value, but in this case, we derived it differently, since in this case, a minimum value is the objective. A specific friction coefficient is the quotient of the characteristic friction coefficient of basic samples (0.55) and the characteristic friction coefficient of the tested sample (e. g. the value of the friction coefficient for the sample no. 60 is 0.467, in this case, the specific friction coefficient is identical to the value of the following fraction:  $0,55/0,467 \approx 1,18$ ). It is apparent that the samples satisfying the requirements are only four since the other samples were not prominent from the aspect of a specific product, or their specific mechanical properties did not reach the minimum value selected. Thus, due to selections presented earlier, it can be established that in order to improve tribology properties, the formulation of the above four samples should be perfected.

### Examination of electrical properties

For reaching antistatic characteristics the carbon nanotubes made by different methods are proper. The needed amount of additives are very low, in every case the volume is below 0.1%. Independently from the treatment of carbon nanotubes the antistatic characteristic was reached in every case. (Table 1.)

Table 1. Antistatic samples

Codes of samples	Content of carbon nanotube (%)	Content of graphit (%)	Surface resistance ( $10^9 \Omega$ )
91	0.05%	1.00%	87.00
98	0.05%	1.00%	0.07
105	0.05%	1.00%	0.09
131	0.05%	1.00%	0.7
116	0.05%	2.00%	3.60

The graphite content helped the distribution in the base material. Depending on the treatment of carbon nanotube, the surface resistance could change with 4 orders of magnitude. Further experiments are needed with carbon nanotube used in the sample No. 105, because in this version the mechanical characteristics were more favourable.

### Burning properties, fire behaviour

The cast natural polyamide 6 is easy to burn just like most of the polymers, since they have many carbon and hydrogen atoms. Following the literature the montmorillonite mineral was often found to be suitable to spoil the burning process of some polymers. We also produced montmorillonite composite samples and tested them according to the standard methods. Oxygen index testing and UL-94 burning examination were applied. The results showed a little improvement (1-1.5%) in the Oxygen Index tests comparing to the pure PA6. That means that the burning of montmorillonite composite needed 1.5% more oxygen to keep burning comparing to the natural cast polyamide 6. But during UL-94 tests the effect of the additive was not obvious. The plastic unfortunately was burning during dropping down (Figure 1) with natural and composite samples as well.

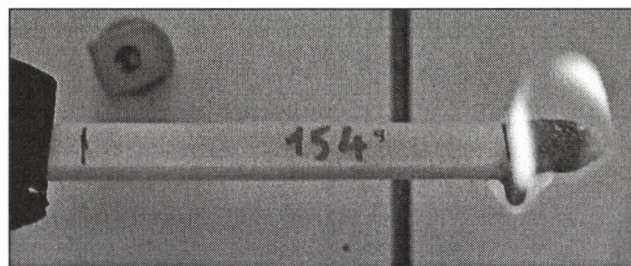

Figure 1 Burning of montmorillonite composite samples during UL-94 test

Finally we concluded that montmorillonite composite needed more oxygen, but the form and method of burning and dropping does not let state better ranking (UL-94) of the composite. Another point came to highlight as influencing factor together with montmorillonite. That is water absorption. Due to "amide" group of molecular structure, all the polyamide types have more or less water absorption capability. The absorbed water content can also influence the burning behaviour, thus we made some control of water absorption of the different test samples.

### Water absorption properties

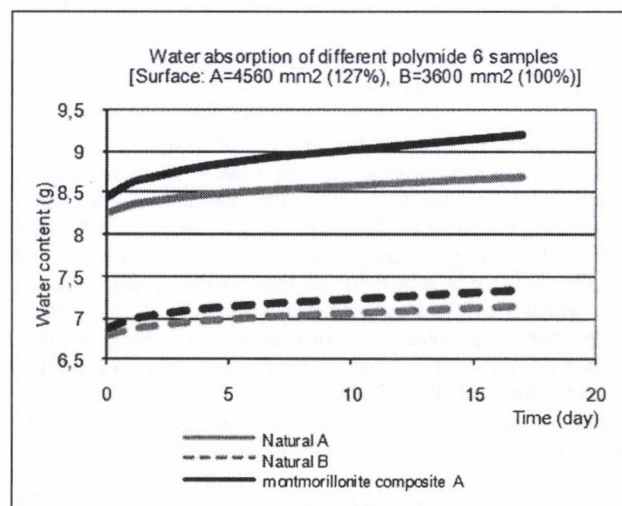

Figure 1 Water absorption of different polyamide 6 samples

During the water absorption tests we applied natural and montmorillonite composite polyamide 6 having 1% montmorillonite samples. The duration was 17 days soaking the samples in 20°C water. After 17 days the natural samples had 5% and the composite ones 7% mass increase in average (fig.2.). The increase of weight accompanied with the change of dimensions of samples, too. Regarding the possible agricultural applications of natural and composite polyamide 6, beside the fire behaviour the water absorption also have to be clarified.

## Conclusion

Based on the first control measurements with the pilot samples we could define a further research plan for a given target additives to achieve better abrasive resistance, lower surface resistivity (antistatic or ESD property) and better fire resistance (table 2.).

**Table 2. Further composite developing project**

	Phase 1.	Phase 2.	Phase 3.	Phase 4.
	Additive	Additive	Additive	Additive
Impact strength	TA-52 (polyether)			
Elongation and tribological properties	MoS <sub>2</sub>			
Tribological property	PTFE			
Surface resistivity and tribological properties	grafit	Carbon nanotubes	EP-120 (dispersent)	Carbon nanotubes
Fire resistance	Montmorillonite			

According to the measured material properties we can state that

- To improve the mechanical properties of the magnesium catalytic natural cast polyamide 6 with additives, the TA-52 polyether and MoS<sub>2</sub> is suitable.
- Regarding the abrasive wear resistance as essential tribological property in the agricultural environment, MoS<sub>2</sub>, PTFE, carbon nanotube and graphite can be applied as additives in different combination and selection.
- Better fire resistance may achieve with montmorillonite additive with a combination of graphite

The carbon nanotube/graphite systems are difficult to produce due to the strongly differing particles and properties. Evenly dispersed system in the liquid caprolactame, which is the monomer state of the cast polyamide 6, is rather complicated chemical engineering task. The carbon nanotube/graphite systems are promising in the field of tribological improvements and antistatic applications, too, so huge research effort is addressed for that chemical engineering stage of the technology.

## Acknowledgement

Many thanks for the industrial partner, Quattroplast Ltd, Gyula Sárosi and János Rosta for chemical engineering and producing the samples for research testing.

## References

- [1] Chow WS - Mohd Ishak ZA. Mechanical, morphological and rheological properties of polyamide 6/organomontmorillonite nanocomposites. *eXPRESS Polymer Letters* (2007); 1(2):77-83.
- [2] Dong W - Zhang X - Liu Y - Wang Q - Gui H - Gao J - Song Z - Lai J - Huang F - Qiao J. Flame retardant nanocomposites of polyamide 6/clay/silicone rubber with high toughness and good flowability. *Polymer* (2006); 47(18):6874-6879.
- [3] Gächter R - Müller H. *Műanyagadalékok zsebkönyve*. Budapest: Műszaki Könyvkiadó (1989).
- [4] Jaklewicz M - Litak A - Ostojca-Starzewski M. Friction and scratch resistance of polyamide 6 modified with ionomeric ethylene/methacrylic acid copolymer. *Journal of Applied Polymer Science* (2004);91(6):3866-3870.
- [5] Jang BN - Wilkie CA. The effect of clay on the thermal degradation of polyamide 6 in polyamide 6/clay nanocomposites. *Polymer* (2006); 46(10):3264-3274.
- [6] Kalácska G. *Műszaki polimerek és kompozitok a gépészmérnöki gyakorlatban*. Gödöllő: 3C-Grafika Kft 2007.
- [7] Li JH - Feng LL - Jia ZX. Preparation of expanded graphite with 160 μm mesh of fine flake graphite. *Materials Letters* (2005); 60(6):746-749.
- [8] Novák I - Krupa I. Electro-conductive resins filled with graphite for casting applications. *European Polymer Journal* (2004);40(7):1417-1422.
- [9] Pál K. *Műanyagok éghetőségének csökkentése töltőanyaggal*. *Műanyagipari Szemle* (2006); 3(6):33-41.
- [10] Pásztor M - Orbán S. Fénystabilizálás, színezés, antisztatizálás, antibakteriális adalékok. *Műanyagipari Szemle* (2006); 3(2):13-19.
- [11] Piddubnyi VK - Zin' IM - Lavryshyn BM - Bilyi LM - Kolodii YI - Ratushna MB. Effect of carbon-containing conducting fillers on the properties of epoxy coatings. *Materials Science* (2005); 41(2):265-270.
- [12] Potschke P - Haussler L - Pegel S - Steinberger R - Scholz G. Thermoplastic polyurethane filled with carbon nanotubes for electrical dissipative and conductive applications. *KGK-Kautschuk Gummi Kunststoffe* (2007); 60(9):432-437.
- [13] Rusu G - Rusu E. In situ nylon 6/graphite composites. Physico-mechanical properties. *Journal of Optoelectronics and Advanced Materials* (2007); 9(7):2102-2109.
- [14] Samyn P - Kalacska G - Keresztes R - Zsidai L. De Baets P. Design of a tribotester for evaluation of polymer components under static and dynamic sliding conditions. *Proceedings of the Institution of Mechanical Engineers, Part J, Journal of Engineering Tribology* (2007); 221(6): 661-674.
- [15] Song L - Hua Y - Lina Z - Xuana S - Wang S - Chenb Z - Fan W. Preparation and properties of halogen-free flame-retarded polyamide 6/organoclay nanocomposite. *Polymer Degradation and Stability* (2004); 86(3):535-540.
- [16] Xu HY - Feng ZZ - Chen JM - Zhou HD. Tribological behavior of the polyamide composite coating filled with different fillers under dry sliding. *Journal of Applied Polymer Science* (2007); 104(4):2554-2560.
- [17] Zsidai L - De Baets P - Samyn P - Kalacska G - Van Peteghem AP, Parys F. The tribological behaviour of engineering plastics during sliding friction investigated with small-scale specimens. *Wear* (2002); 253 (5-6):673-688.

## DETERMINING THE PARAMETERS OF MILD HEAT TREATMENT DESTROYING *CLOSTRIDIUM PERFRINGENS*

Zsófia SIPOS-KOZMA<sup>1</sup> - Jenő SZIGETI<sup>1</sup> - László VARGA<sup>1</sup> - Balázs ÁSVÁNYI<sup>1</sup> - Noémi ÁSVÁNYI-MOLNÁR<sup>1</sup> - Zsolt TURCSÁN<sup>2</sup>  
<sup>1</sup> University of West Hungary, Institute of Food Science, Faculty of Agricultural and Food Sciences, Mosonmagyaróvár  
<sup>2</sup> 46 Fáy Street, 5800 Mezőkovácsháza

### Introduction

The heat tolerance of *Clostridium perfringens*, an endospore-forming anaerobic pathogen, was studied in our experiments. Earlier examinations determined that livers from waterfowl contained up to 5-10 CFU/g *C. perfringens* spores in large-scale industrial operations. By contrast, the counts of *C. perfringens* spores in livers from waterfowl in France were occasionally found to be as low as 1-2 CFU/g. This is most likely due to the differences in slaughtering technology because in Hungary the large-scale conveyor applies cold evisceration, whereas in France warm evisceration is used in small-scale commercial operations, therefore, the risk of contamination is thus reduced. The aim of this study was to determine the minimum heat dose, not exceeding 100°C, needed to produce semi-preserved waterfowl liver. For reasons of competitiveness, it is necessary to use reduced temperatures because French products made from less contaminated raw materials are heat treated at temperatures ranging from 95°C to 98°C, whereas Hungarian semi-preserved livers are heat at 105-108°C.

### Characterization of *Clostridium perfringens*

*Clostridium perfringens* was first characterized by Welch in 1892. He had designated the organism as *Bacillus aerogenes capsulatus*, but it was later re-named *Bacillus phlegmonis emphysematosae*, or Fränkel-bacillus [1]. It also used to be well-known as *Clostridium welchii* [9].

*Clostridium perfringens* is a Gram-positive, rod-shaped, anaerobic, spore-forming bacterium without flagella. It is capable of producing a polysaccharide capsule [9]. Its size ranges between 0.9 to 1.3 µm (width) and 3 to 9 µm (length). The oval-shaped spores are mostly located in a central position in the vegetative cell [7], [9].

*Clostridium perfringens* is ubiquitous in nature and can be found in soil, human and animal stool and sewages [8]. When in the soil, the organism creates spores for survival. Getting back into the gastrointestinal tract of animals from the surface of plants, it has then various ways to spread. It occurs rarely in dry circumstances, e.g., in deserts. Because of the active biochemical processes in the soil, microbes have an important role in decomposition of organic substances, such as proteins and carbohydrates [1].

### Heat resistance of microorganisms

Heat resistance is primarily a genetically determined feature of microbes, which is, however, dependent upon environmental conditions as well. The death of microorganisms is examined through the enumeration of surviving and viable cells. Ideally, the thermal death time curve is totally linear, however, in some cases, linearity is limited to a certain region. Consequently, the changes in the number of viable cells are not always of exponential nature [4], [5].

Decimal reduction time (D value) is the time in minutes during which the number of a specific microbial population exposed to a specific temperature is reduced by 90% [5]:

$$D = \frac{t}{\log N_1 - \log N_2} \quad [3]$$

where  $t$  is the time (in minutes) for 1 log reduction of the microbial strain used, and  $N_1$  and  $N_2$  represent microbial numbers before and after heat treatment for  $t$  min.

Microorganisms differ in heat tolerance, and their heat destruction rate depends on the temperature used, as is indicated by the  $z$  value, which is the slope of the thermal death time curve [4].

$$t g \alpha = -\frac{1}{z} \quad [4]$$

The  $Q_{10}$  value is used to describe temperature dependence. The relationship between the  $Q_{10}$  and  $z$  values can be determined on the basis of the thermal death time curve as follows [4]:

$$Q_{10} = 10^{\frac{10}{z}} \quad [4]$$

In addition to the  $z$  value, the  $F$  value is also used to describe the temperature dependence of microbial heat destruction. The  $F$  value is the time (min) necessary to completely destroy a specific number of microbial spores at a reference temperature of 121.1°C. If the  $F$  value is known,  $t$  destruction time can be calculated at any given temperature ( $T$ ) according to the following formula:

$$\frac{F}{t} = 10^{\frac{T-121.1}{z}}$$

Based on the  $F$  value, relative death rate (RDR) can be calculated, which indicates how many times the death rate of a specific organism is higher or lower at temperature  $T$  than at 121.1°C. The reciprocal of RDR is known as relative death time (RDT) [7].

### Materials and methods

Heat treatment trials were performed on *Clostridium perfringens* NCAIM B.01417, which was obtained in freeze-dried form from the National Collection of Agricultural and Industrial Microorganisms (Budapest, Hungary). It was incubated at 37°C for 7 days in Reinforced Clostridial Medium (RCM; Merck KgaA, Darmstadt, Germany), and then a concentrated suspension was produced by centrifugation in sterile centrifuge tubes (30 cm<sup>3</sup>). The following parameters were set for centrifugation: 5000 rpm, 4500 g, 15 min and 10°C. The supernatant was then removed, and a pure suspension was prepared by dilution with quarter-strength Ringer's solution.

### Enumeration of vegetative cells and spores

After purification, vegetative cell counts and initial spore counts were determined. For the determination of vegetative cell counts, unheated samples were pour-plated on Plate Count (PC) agar and Tryptose Sulfite Cycloserine (TSC) agar. Initial spore counts were enumerated in samples heated at 80°C for 10 min and then plated on the culture media mentioned (i.e., PC and TSC agars). All the plates were incubated anaerobically.

In order to promote the spore formation of *C. perfringens* the content of each centrifuge tube (30 cm<sup>3</sup>) was poured into a special broth (500 cm<sup>3</sup>) developed by Duncan and Strong [6]. The samples were incubated at 37°C for 72 h under anaerobic conditions, and were subsequently stored in a refrigerator at 4°C for 24 h.

### Heat treatment trials

For spore count determinations, samples were subjected to heating at 80°C for 10 min. Each of 10 cm<sup>3</sup> *Clostridium*

*perfringens* spore suspensions were placed in a water bath set at 80°C, 85°C, 90°C or 95 °C and kept for various periods of time. The spore counts of heat-treated suspensions were determined by the pour-plate technique using PC agar incubated at 37°C for 2 days. The entire experimental program was repeated three times.

## Results

### Enumeration of vegetative cells and spores

The results of vegetative cell and spore count determinations are shown in Table 1.

**Table 1** Vegetative cell counts and initial spore counts of *Clostridium perfringens*

<i>Clostridium perfringens</i>	PC agar	TSC agar
Vegetative cell count (CFU/cm <sup>3</sup> )	1.6 × 10 <sup>3</sup>	1.5 × 10 <sup>3</sup>
Initial spore count (CFU/cm <sup>3</sup> )	< 1.0 × 10 <sup>0</sup>	< 1.0 × 10 <sup>0</sup>

The final spore counts of *C. perfringens* were found to be as high as 2.8 × 10<sup>4</sup> CFU/cm<sup>3</sup>.

### Heat treatment trials

Fig 1 illustrates the results of heat treatment trials.

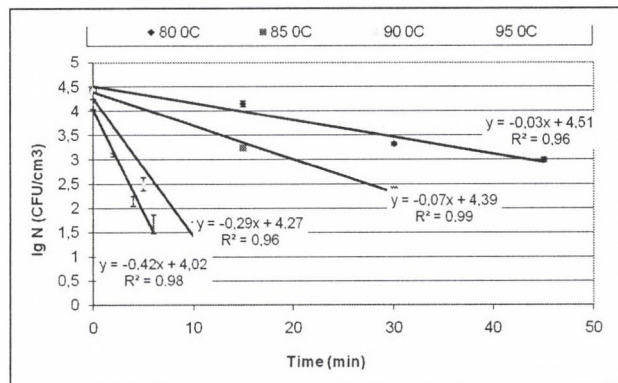

**Figure 1** Survival curves of *Clostridium perfringens* at 80°C, 85°C, 90°C and 95°C

Table 2 shows the decimal reduction times of *C. perfringens*.

**Table 2** D, lg D and lg t values of *Clostridium perfringens*

Temperature (°C)	D value (min)	lg D value	lg t
80	30.82	1.49	2.569
85	13.08	1.11	2.189
90	3.49	0.54	1.619
95	2.19	0.34	1.419

After logarithmic transformation, decimal reduction times were plotted against heating temperature; and thermal resistance and death time curves were thus obtained (Fig. 2).

Q<sub>10</sub>, z and F values were calculated from the equation showing the slope of the death time curve in Fig. 2. The z value of *C. perfringens* was found to be 12.43°C, indicating that 12.43°C is required to change the D value (or thermal death time) to transverse by 1 log. The Q<sub>10</sub> value of *C. perfringens* was calculated to be as high as 6.36, indicating that an increase of 10°C in temperature resulted in a death rate 6.36 times higher than the initial one.

The calculated z value can be used to determine the relative death rate (RDR) at a specific temperature. The relative death rates (RDR) and relative death times (RDT) of *C. perfringens* are shown in Table 3.

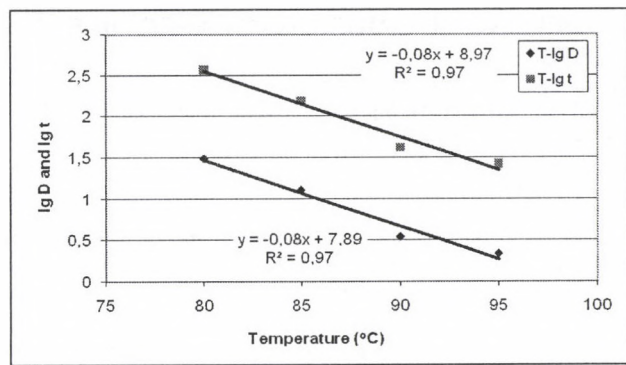

**Figure 2** Thermal resistance and death time curves of *Clostridium perfringens*

**Table 3** Relative death rates and times of *Clostridium perfringens*

Temperature (°C)	Relative death rate (RDR) (min <sup>-1</sup> )	Relative death time (RDT) (min)
80	0.0005	2041
85	0.0012	802
90	0.0031	318
95	0.0079	126

It is seen in Table 3 that, at 90°C, the RDR and RDT values of *C. perfringens* were 0.0031 min<sup>-1</sup> and 318 min, respectively, indicating that the speed of spore destruction was 318 times lower at 90°C than at 121.1°C.

## Conclusions

The spore counts of *C. perfringens* were reduced by 2 log cycles within 27 min and 5 min at 85°C and 95°C, respectively. For this reason, it is suggested that a reasonably low temperature, not exceeding 100°C, can be used to adequately destroy *C. perfringens* spores.

## Acknowledgments

This work was funded by a grant (OM-00159/2007) from the National Office for Research and Technology, Hungary.

## References

- [1] Alföldy Z., Ivánovics GY. & Rauss K. (1963) Orvosi Mikrobiológia. Medicina Egészségügyi Könyvkiadó, Budapest. pp. 348-352.
- [2] Byrne, B., Dunne, G. & Bo' n, D. J. (2006): Thermal inactivation of *Bacillus cereus* and *Clostridium perfringens* vegetative cells and spores in pork luncheon roll. Food Microbiology 23, 803–808.
- [3] Deák T. (1979) Tartósítóiipari mikrobiológia. Kertészeti Egyetem, Egyetemi jegyzet, Budapest. pp. 146.
- [4] Deák T., Lukasovics F., Reichart O. & J. Román M. (1999) Mikrobiológiai gyakorlatok II. Interagent Kiadó és Nyomda Kft, Budapest. pp.67-72.
- [5] Deák T. (2006) Élelmiszer-mikrobiológia. Mezőgazda Kiadó, Budapest. pp.47, 138.
- [6] Duncan, C.L. & Strong, D.M. (1967) Improved medium for sporulation of *Clostridium perfringens*. Applied Microbiology. pp. 82-89
- [7] Kovács Á. (1997) Az élelmiszertudomány alapjai III. Élelmiszerek mikrobiológiája és mikroökológiája. Pécsi Orvostudományi Egyetem Egészségügyi Főiskolai Kar, Pécs. pp.148.
- [8] Rohrs, B. (1994) *Clostridium perfringens*: Not the 24 hour flu. Center for Food Safety & Applied Nutrition, MMWR 43 (8)
- [9] url<sup>1</sup>: en.wikipedia.org

## MODELLING OF HARVESTING BASED ON FIELD TESTS

Zoltán BÁRTFAI - Péter ILOSVAI

Szent István University, Institute of Systems Engineering and Management, Gödöllő

### Introduction

According to the characteristic feature of the Hungarian plant cultivation the cereals and maize are grown approximately on the 50 % of the total cultivable land. The changes in the ownerships the deficiency of funds, the problems in disposal will facilitate the closing up to the severe regulations of the EU about the environmental protection and the product quality. At least in the respect of the production technologies, in so far as the cheaper, simpler solutions will be used. In this case the crop capacity naturally will be lower. In the first place from the example of the USA in the countries of the EU, the new technologies started to spread earlier but nowadays in Hungary we also use these technologies in the plant cultivation. These changes in the technologies have modified the proportions of direct costs of the production circulation. Fundamental changes can be experienced in the preparation of soil, substitution of nutrition and because of the environmental-protection requirements these changes can be experienced in the plant protection too. Figure 1 shows the cost proportions of the maize production in Hungary in different type of soil cultivation systems.

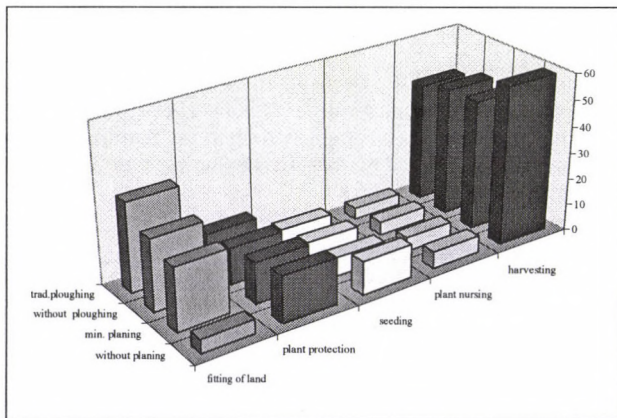

Figure 1 Cost proportions of the maize production in Hungary in different type of soil cultivation systems.

The diagram shows that the costs of the harvesting relatively increased comparing it with the other operation costs. Considering the fact that harvesting is the realization of the production results and also that the possibility of the direct losses is really expressive in this operation, it is calculable with a well organized process the scale of the production process can be influenced advantageously. Figure 2 shows the effect of the harvesting time (regarding to the moisture content) deviating from the optimum on the grain quantity that can be harvested. The main goal is to utilize in the best range the harvesting capacity which claims on the one hand the knowledge of parameters that have an effect on the machine harvesting performance and on the other hand the knowledge of those factors which have effect on the transport capacity.

### Discussion

The maize harvesting process can be considered as an assembly in which the elements are in complicated relationship with each other. Another complication in this assembly is the incidence state of the elements can be many variegated. In consequence of this fact the planning possibility of the harvesting process

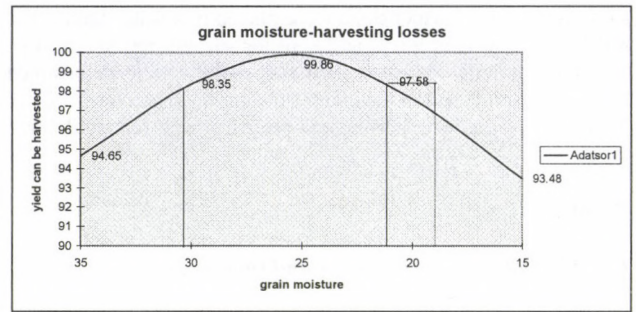

Figure 2 Effect of the moisture content on the grain quantity

depends on the handling of the harvesting machine (combine)-environment and the combine environment-lorry connections as a complex system. The system approach may ensure a better scientific cognition of the real process through the application of system methods like example modelling.

The model- as a short definition- is a transformation of the system by the aid of the expediently choiced essential features, properties of the system. Thus the model contains those parameters of the examined system which are relevant from the point of the examination. These parameters or features of the system have to be determined by exacting investigations. To determine of the essential parameters of the combines there are international (e.g. ASAE) and national standards which contains and prescribe the topic, the method and also the quality requirements of the scientific investigation. To apply these standards in case of maize combines the next parameters have to be determined through the investigation:

#### Conditions of the investigation

- configurations of the terrain
- crop- features
- breed
- row place
- distance between plants in the row (average)
- yield of the grain
- proportion of the grain-cob
- grain-moisture

#### Characteristic features of the examined machine

- energetic features
- engine revolution per minute
- fuel consumption
- travelling speed

#### Performance features

- time while the grain tank filled up
- emptying time
- revolution of the barrel

#### Quality features

- grain losses(car-beating adapter, screen, shaking box, leakages)
- grain cleaners
- grain breaking
- proportion of the grain-stalk

Table 1 summarises data that were taken during a field test of a SAMPO Rosenlow 2075 type combine harvester.

On the basis of the chart the boundary use values determinable for the case of boundary conditions stipulated by the severe standards (Hungarian Standard: 1.5 % losses, ASAE 1 % losses). Making use of the data and altering the harvesting conditions (e.g. yield) fulfilling the modelling the operating parameters of the combine harvester can be determined. The model conditions may deviate from the original field conditions. These parameters generate the transporting claim (Figure 3.). The transport vehicles have to satisfy all these requirements according to the cost proportions showed by the Figure 1 and 2.

Table 1

engine revol.	aver. speed	fuel cons.	Spec.fuel. consumpt	area capacity	grain masse	masse	grain losses
[1/min]	[km/h]	[l/h]	[l/ha]	[ha/h]	[kg/sec]	[kg/sec]	[%]
2242	4.20	21.77	17.14	1.27	4.29	5.81	1.09
2217	5.39	25.13	15.41	1.63	5.51	7.46	1.62
2236	5.49	23.77	14.29	1.66	5.62	7.60	1.71
2194	5.66	23.72	13.84	1.71	5.79	7.83	1.72
2226	6.40	25.25	13.04	1.94	6.54	8.85	2.18
2201	6.41	25.95	13.37	1.94	6.56	8.87	2.23
2214	6.53	25.69	12.99	1.98	6.68	9.04	2.22

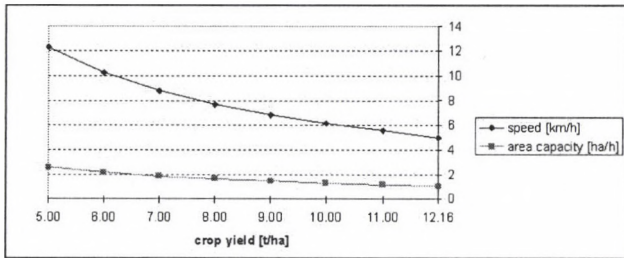

Figure 3 Expectable parameters of the combine harvester SR2075 taken as a function of the crop yield

Namely over the period of harvesting the two processes create the real work-process, and there are two possibilities – the combine harvester waits for the transport vehicle – the transport vehicle waits for the combine harvester

These situations can be taken into consideration in the course of simulation and over a period of formation of the computer model. Going on the analysis of the harvesting process we can make certain that it is a special kind of serving systems really a mass-serving system taking no notice of rejecting the arising claims. Simultaneously the system has several channel if there are two or more transport vehicles at the same time. If we would like to create the model we have to have knowledge about the following data:

- technical working parameters the combine harvester
- number of the machines working in the harvesting process
- technical working parameters of the transport vehicles
- the average yield of the field
- habitat features (size of the yield, soil, relief)
- haul length (transport distance)
- road conditions
- conditions of the receiving and loading.

Studying the connections between the elements, the harvesting process can be described only on the basis of the probability and the active factors have to be handled as random variables. Let's study the time when raising a claim to serve the combine harvester. Let it be marked by "tj". It is a probability value, that depends on several random time- elements, which are connecting with each other (e.g. previous serving time, time of the filling up of the grain tank, emptying time of the grain tank, failure probability of the attachments of the machines). Considering only the grain tank filling up time, its value depends on several random variables, like: working width, travelling speed, capacity of the grain tank, crop yield of the examined part of the field, field length and other features of the yield.

**Conclusion**

The random model, which is created by considering the principles, mentioned above, has peculiarities from them it emerges that we get the results in the form of some distribution. The result will be the value of the distribution. The results of our investigation, which have been taken on the mentioned Sampo combine harvester, can be seen in the Table 2 and in the Figure 4. and 5.

We hope the results of this computer aided modelling will help to make decision of planning and guiding activities in a concrete situation or process.

Table 2

type of the combine harvester: SR 2075  
 capacity of the grain tank: 4.6 m<sup>3</sup>; technical reliability factor: 0.992  
 type of the transport vehicle: FIAT 180.90+MBP 6.5(2)  
 technical reliability factor: 0.991; load capacity (t): 13  
 travelling distance (km): 5; average speed (km/h): 19

Number of trans. veh.		1	2	3	4
Number of combine		Average waiting time [min]			
1	combine	227	0	0	0
	transp.veh.	0	220	776	1334
2	combine	796	408	113	0
	transp.veh.	0	19	54	428
3	combine	1340	965	589	262
	transp.veh.	0	19	38	80
		Estimated total capacity [t/h]			
1		8.3	12.9	12.9	12.9
2		8.3	15.6	23.0	24.8
3		8.3	15.6	23.0	30.4

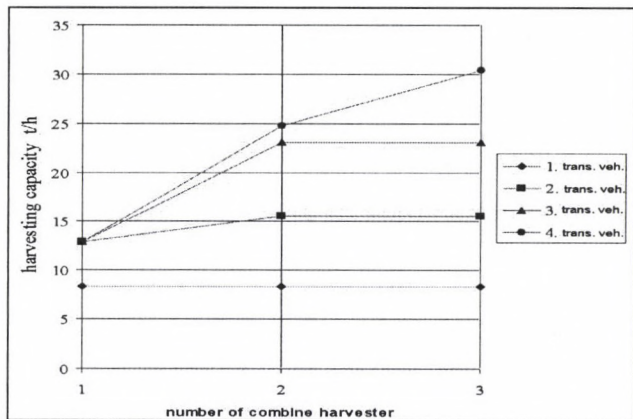

Figure 4 Connection between the harvesting capacity, number of transport vehicle and combine harvesters

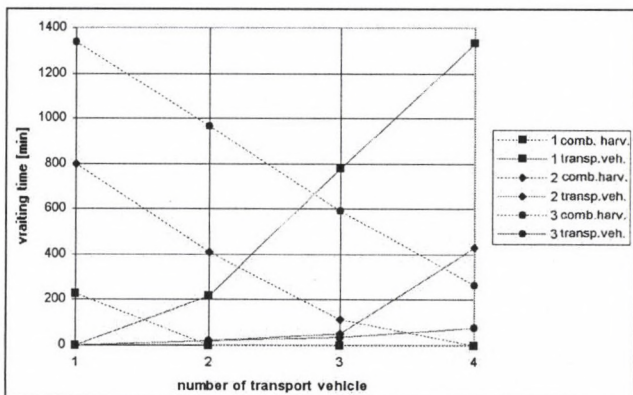

Figure 5 Connection between the waiting time, number of transport vehicles and combine harvesters

**References**

[1] Stafford, J. V. (ed.): Precision Agriculture '99, Sheffield Academic Press, Sheffield, 1999.  
 [2] Gaynor, G.H.: Handbook of technology management, McGraw Hill, New York, 1996.  
 [3] Liljedahl J.B., Turnquist P.K., Smith D.W., Hoki M.: Tractors and their power units Van Nostrand Reinhold, New York, 1989.

# Contents of N° 21/2008

<b>EVALUATION OF THE ACCURACY OF THE AISA DUAL HYPER SPECTRAL SYSTEM IN HUNGARY</b> József DEÁKVÁRI <sup>1</sup> - László KOVÁCS <sup>1</sup> - László FENYVESI <sup>1</sup> - Péter BURAI <sup>2</sup> - Csaba LÉNÁRT <sup>2</sup> <sup>1</sup> Hungarian Institute of Agricultural Engineering, Gödöllő <sup>2</sup> Department of Water- and Environmental Management in University of Debrecen, Centre of Agricultural and Technological Sciences .....	12	<b>HUNGARIAN SUSTAINABLE ENERGY FINANCING FACILITY - MARKET ASSESSMENT FOR SUSTAINABLE ENERGY PROJECTS</b> Sándor MOLNÁR <sup>1</sup> - Márk MOLNÁR <sup>2</sup> <sup>1</sup> Szent István University, Department of Informatics, Gödöllő <sup>2</sup> Szent Istvan University, Faculty of Economics and Business Management, Gödöllő .....	44
<b>RESEARCH FOR REDUCTION OF THE ENVIRONMENT DAMAGING EFFECTS OF SPRAYING</b> Zoltán GULYÁS - László KOCSIS Hungarian Institute of Agricultural Engineering, Gödöllő .....	15	<b>THEORY OF WOOD FIRING, SMALL BOILERS</b> István SZTACHÓ-PEKÁRY College of Kecskemét.....	48
<b>STRAIN MEASUREMENT WITH FIBER SENSOR</b> Károly PETRÓCZKI Szent István University, Faculty of Mechanical Engineering, Institute of Process Engineering, Gödöllő .....	17	<b>DEVELOPMENT OF FOREST MACHINE IN RECENT PAST IN HUNGARY</b> Béla HORVÁTH Institute of Forest- and Environmental Techniques, University of West Hungary, Sopron .....	51
<b>CONTINUOUS TILLAGE FORCE MEASUREMENTS – NEW DEVELOPMENTS</b> Mátyás CSIBA - Miklós NEMÉNYI University of West Hungary, Faculty of Agricultural and Food Sciences Institute of Biosystems Engineering, Mosonmagyaróvár.....	19	<b>EXPERIMENTAL PAVEMENTS BUILT ON COHESIVE SOIL</b> József PÉTERFALVI - Miklós KOSZTKA - Gergely MARKÓ - Péter PRIMUSZ University of West-Hungary, Faculty of Forestry, Institute of Geomatics and Civil Engineering.....	53
<b>ANALYSIS OF CORRELATION BETWEEN THE LOOSENESS DEGREE OF SOIL AND THE TRAVEL SPEED OF THE TILLING COMBINATION</b> Péter RÁCZ – Zsolt SZÜLE Szent István University, Institute of Mechanics and Machinery, Gödöllő.....	21	<b>A COMPARATIVE STUDY ON THE PERFORMNCE OF THREE DIFFERENT BAD SAW BLADES</b> Kinga GERENCSE - Erzsébet VARGA University of West Hungary, Institute of Wood and Paper Industry.....	55
<b>DESIGN OF AXIAL FLOW FAN ROTOR WITH CONSTANT BLADE CHORD METHOD</b> Dániel FENYVESI - Ferenc SZLIVKA Szent István University, Gödöllő .....	23	<b>UTILIZATION OF TERRESTRIAL HEAT FOR AIR- CONDITIONING OF RELAY STATIONS</b> László TÓTH - Norbert SCHREMPF - Lajos FOGARASI - Gábor BIHERCZ Szent István University, Faculty of Mechanical Engineering, Gödöllő .....	58
<b>ANALYSIS OF THE DRYING TECHNOLOGY OF OIL SEEDS AND CORN KERNELS</b> Jenő CSERMELY - Mihály HERDOVICS - József DEÁKVÁRI Hungarian Institute of Agricultural Engineering, Gödöllő .....	25	<b>COMPUTER AIDED MODELLING OF WIND FARMS (ENERGY PRODUCTION)</b> László TÓTH - Norbert SCHREMPF - Annamária KONCZ Szent István University, Faculty of Mechanical Engineering, Gödöllő .....	61
<b>INCREASING THE SOLUBLE ORGANIC MATTER CONTENT AND BIOGAS PRODUCT OF SEWAGE SLUDGE BY MICROWAVE PRETREATMENT</b> Sándor BESZÉDES - Zsuzsanna LÁSZLÓ - Szabolcs KERTÉSZ - Gábor SZABÓ - Cecília HODÚR Faculty of Engineering, Department of Technical and Process Engineering, Szeged .....	27	<b>TECHNICAL CONDITIONS OF ENERGY-CANE GROWING (Development Trends)</b> László BENSE - Zsolt SZÜLE - Lajos FOGARASI Szent István University, Faculty of Mechanical Engineering, Institute of Mechanics and Machinery, Gödöllő.....	64
<b>TECHNICAL-ECONOMICAL CHARACTERISTICS OF MACHINE UTILIZATION IN THE DIFFERENT BRANCHES OF CROP FARMING CONSIDERING PLANT SIZE</b> László MAGÓ Hungarian Institute of Agricultural Engineering, Gödöllő .....	30	<b>CAST POLYAMIDE 6 POLYMER COMPOSITES FOR AGRICULTURAL MACHINE APPLICATIONS</b> Mátyás ANDÓ <sup>1</sup> - Gábor KALÁCSKA <sup>1</sup> - Tibor CZIGÁNY <sup>2</sup> <sup>1</sup> Szent István University, Institute for Mechanical Engineering Technology, Gödöllő <sup>2</sup> Budapest University of Technology and Economics, Department of Polymer Engineering, Budapest .....	67
<b>CHARACTERISTICS OF MACHINE UTILIZATION OF PLANT PRODUCTION FARMS IN HUNGARY</b> Zsolt BARANYAI - István TAKÁCS Szent István University, Faculty of Economics and Social Sciences, Gödöllő .....	35	<b>DETERMINING THE PARAMETERS OF MILD HEAT TREATMENT DESTROYING CLOSTRIDIUM PERFRINGENS</b> Zsófia SIPOS-KOZMA <sup>1</sup> - Jenő SZIGETI <sup>1</sup> - László VARGA <sup>1</sup> - Balázs ÁSVÁNYI <sup>1</sup> - Noémi ÁSVÁNYI-MOLNÁR <sup>1</sup> - Zsolt TURCSÁN <sup>2</sup> <sup>1</sup> University of West Hungary, Institute of Food Science, Faculty of Agricultural and Food Sciences, Mosonmagyaróvár <sup>2</sup> 46 Fáy Street, 5800 Mezőkovácsháza .....	70
<b>USAGE SIMPLEX METHOD TO DETERMINE REQUIRED NUMBER OF TRACTOR SYSTEMS FOR PLOUGHING</b> Lazar SAVIN - Ratko NIKOLIĆ - Timofej FURMAN - Milan TOMIĆ - Mirko SIMIKIĆ Faculty of Agriculture, University of Novi Sad, Serbia .....	38	<b>MODELLING OF HARVESTING BASED ON FIELD TESTS</b> Zoltán BARTFAI - Péter ILOSVAI Szent István University, Institute of Systems Engineering and Management, Gödöllő .....	72
<b>CLOSING FORCE MEASUREMENT ON CRIMPED CLOSURES</b> Zsolt MAGYARY-KOSSA <sup>1</sup> - János BENKÓ <sup>2</sup> - Gyula VINCZE <sup>2</sup> <sup>1</sup> Sure TORQUE Európa Kft., Budapest <sup>2</sup> Szent István University, Gödöllő.....	41		

Contents of the  
**“Mezőgazdasági Technika”**  
 periodical of the year 2008.

**MEZŐGAZDASÁGI**  
**TECHNIKA**  
 2100 GÖDÖLLŐ, TESSEDIK S.U.4.

**N° 1**

Possibilities of utilization of the telessensing in the agriculture (J. Deákvári – L. Fenyvesi – L. Kovács – Z. Papp).....	2
Cold storage of grain (Gy. Komka).....	5
Cleaner Diesel motors - the AbBlue-technology (V. Varga).....	25
The technical background of the production of quality fodder with the help of balers (Z. Bellus).....	42
The partner of GITR at the Agritechnica (G. Pálkás).....	46

**N° 2**

Investigation to energy saving threshing of cereals (Z. Láng).....	2
A new vegetable oil processing plant in Sarkad (M. Herdovics).....	6
Results of the competition for „Grand Prix“ and „Special Prize“ of the exhibition Agro+Mashepo 2008 (J. Hajdú).....	12
The history of Bibendum – I. The very beginning (M. Szente).....	36
Costs of mechanized works in the agriculture in the year 2008 (L. Gockler).....	40

**N° 3**

Energetically comparison and working quality of tools of middledeap-grubbers (P. Rácz – Zs. Szüle).....	2
New developed nozzles for spraying equipments (I. Sztachó-Pekár).....	5
DLG-surveying of satisfaction (J. Hajdú).....	12
Equipments for building of beds and dams, furthermore for embanking of dams (J. Fűzy).....	21
Present and future of the technical development in forestry (B. Horváth).....	27
Agro+Mashepo 2008 <i>Part II.</i> (A. Horváth – G. Pálkás).....	40

**N° 4**

Measuring of the dynamical friction factors of fertilizers (Á. Gindert Kele – Z. Hagymássy).....	2
Questions on using of chemical energy sources (L. Tóthné Heim – Z. Peterdi – Sz. Zvekán).....	5
Chopper of the World (J. Hajdú).....	14
About combine harvesters (I. Sörös).....	21
Importance of the economical establishment of the development of the mechanization (I. Husti).....	40

**N° 5**

Innovative process for conservation and storage of chopped alfalfa (Z. Bellus – Sz. Orosz).....	2
Requirements of environmental protection and technologies of the animal husbandry (L. Fenyvesi – L. Tóth – I. Pazsiczki).....	6
Comparative tests of the energy consumption and the quality parameters of apple-drying (T. Antal – I. Szöllösi).....	12
X. TECHAGRO in Brno (Z. Bellus – A. Horváth).....	18
VII. Axiál Professional Days in Lajosmizse (A. Horváth – G. Pálkás).....	30

**N° 6**

Continuous measuring of the soil resistance – new discoveries (M. Csiba – Zs. Stépán – G. Milics – M. Neményi).....	2
Using of the geothermal energy through heath pumps (L. Tóth – A. Ménesi).....	4
The West-European tractor market in 2007 (J. Hajdú).....	14
Self-propelled sprayers (Gy. Dimitrievits).....	21
Actual situation of the Hungarian energy economy in mirror of the EU-member states <i>Part I)</i> (L. Gockler).....	40

**N° 7**

Heat technical analysis of the drying of hybrid-maize (J. Beke – Z. Kurják – G. Bihercz).....	2
Combine harvesters <i>Part II</i> (I. Sörös).....	21
50 years Manitou, 10 years connections to Axiál (J. Hajdú).....	28
Partner meeting Massey Ferguson and Vogel-Noot (A. Horváth).....	30
Actual situation of the Hungarian energy economy in mirror of the EU-member states <i>(Part II)</i> (L. Gockler).....	40

**N° 8**

Examination of the abrasive wearing effect of soils in case of plastic/steel cog-wheel pairs (G. Kalácska).....	2
Mechanization of the animal breeding in Israel (L. Tóth).....	5
The maize-production technology of HORSCH (A. Horváth).....	14
The barometer of the machine investments and the companies’ image in six countries (J. Hajdú).....	16
Combine harvesters <i>Part III</i> (I. Sörös).....	29
Change of the most important parameters of the agricultural machine operation in the basis farms of the institute MGI (L. Gockler).....	54

**N° 9**

The effect of the power shift gear on the exertion of the traction power of tractors (A. Lengyel – A. Szegedi).....	2
Technical conditions, development trends at the production of energy cane (L. Bense – Zs. Szüle – L. Fogarasi).....	5
What we have to know about the different definitions of energy? (M. Szente).....	21
Show of CLAAS-novelties (A. Horváth).....	30
Advantages of using of modern self-propelled machines and tractors in the agriculture <i>(Part I.)</i> (L. Gockler).....	38

**N° 10**

Corn separation at combine harvesters (I. Bognár – P. Szendrő).....	2
KITE field demonstration in Hajdúböszörmény (J. Hajdú).....	5
Farmer Days Bábolna 2008 (Part I.) (A. Horváth).....	21
Harvesters for energetic plantations (Zs. Kelemen).....	30
Advantages of using of modern self-propelled machines and tractors in the agriculture <i>(Part II.)</i> (L. Gockler).....	38

**N° 11**

Automatic paprika sorting with encased form recognition system (Z. Gergely – E. Judák).....	2
Peak output in the manufacturing of agricultural machines worldwide (J. Hajdú).....	5
International Farmer Days Bábolna 2008 (Part II.) (A. Horváth – G. Pálkás).....	12
Tractors à la JCB - new Series 7000 Fastracs (G. Pálkás).....	16
Machines and equipments for potato storage halls (J. Fűzy).....	21
Effect of tractor chassis on the compacting of soil (I. Jóri J.).....	32

**N° 12**

Chassis and traction power – Part I. (M. Szente).....	2
Soil considerate distribution of liquid manure (J. Hajdú).....	4
Euro Tier – Novelties in the mechanization of animal husbandry (J. Bak – Gy. Mészáros – I. Pazsiczki).....	12
Machines and equipments for potato storage halls - Part II. (J. Fűzy).....	21
International Farmer Days Bábolna 2008 (Part III.) (A. Horváth – G. Pálkás).....	28

Do you want to know more from  
**Hungarian Agriculture Machinery!**

**SENDTMS ORDER FROM TO:**

The Hungarian Agricultural Machinery Journal  
H-2001 Gödöllő, Tessedik Sámuel u. 4.

**ORDER FORM**

I want order the Hungarian Agriculture Machinery Journal  
from ..... day ..... month 200.....

The subscription fee: 3240 HUF

Name: .....

Adress: .....

Code, City: .....

Country: .....

Date: ..... day ..... month 200.....

.....

signature

