

## RECENT APPLICATIONS OF THE RENEWABLE ENERGIES

### Author(s):

F. Farkas – T. Molnár

### Affiliation:

University of Szeged Faculty of Engineering, Technical Institute; Mars str. 7., 6724, Szeged, Hungary

### Email address:

farkasf@mk.u-szeged.hu, molnart@mk.u-szeged.hu

### Abstract

Renewables excluding large hydro accounted for 48% of new GW capacity added worldwide in 2014, so the renewable energies increased to 15.2% of world cumulative generation capacity, from 13.8% in 2013. In the EU the new version of the Renewable Energy Directive (RED) distributes the 10% cal. biofuels target into a share for crop-based biofuel (limited at 7% cal.) with the rest to be met with another biofuels and renewable electricity containing multiple counting possibilities. [2,3] For ethanol fuel, more growth could theoretically arrive from an extending of E-10 in EU member states. Unnecessary to discuss that an outlook for a post-2020 biofuels target at the EU level does not valid. [1, 5] In our country and world-wide the amount of waste is growing rapidly due to economic development. It is true that the amount of selectively collected waste is also increasing and also the quantities of secondary materials as recycled materials quantities - so they can get back into the manufacturing process – however it is an important task to dispose of the waste at an up-to-date and environmentally friendly location. The theoretical and practical phenomenon confirms that processing the generated waste by modern European Union-compliant technology systems can be used as alternative energy instead of fossil energy sources to produce electricity and heat.

### Keywords

renewable energies, blending ratio, bioethanol fuel demand, landfill gas, municipal solid waste

### 1. Introduction

The research fields at our Technical Institute, on the Engineering Faculty, of the University of Szeged are

as follows: the development of the combustion characteristics of the bioethanol propellant and the change, brought on by the utilization ratio, in operating factors, also the garbage lot's extraction of landfill gas and its energetic utilization. During the extraction of the landfill gas, due to change in the methane content values, which influence the energetic utilization, we examined the landfill gas values and later on we plan to use it in our experimental engine.

For this project two different manufacturer's bioethanol fuels were assessed with regard to their combustion behaviours by unchanged settings. In order to implement the objectives of research task the comparative analysis were made with two different manufacturer's bioethanol fuels (E85 Sample 1., E85 Sample 2.) and their blends in the engine testing brake [3].

Our aims were under the landfill gas test to examine the quality and quantity parameters of landfill gas changes with regard to the average temperature interval, relative humidity, wind speed interval, precipitation and the change in the organic matter content of the waste disposed. The external characteristics of the refuse dump and its environment were relevant such as weather data between which I looked for connections by mathematical statistical methods.

The connections between the examinations of the bioethanol and landfill gas are the following:

1. Possible practical applications of energetic utilization, from the perspective of the product, by-product and waste produced in the agricultural and communal sector [2, 21, 22].
2. It meets the requirements of the domestic and EU directives' admixture quota, and the regulations in effect, which state the rules regarding a garbage lot's extraction of landfill gas and energetic utilization. Thereby reducing the use of fossil fuels in the communal sector.

3. Due to the viewpoints of environmental protection regarding bioethanol, and in the case of the operation of landfill gas, we expect improvement with emission limit values, and we also expect the mitigation of Greenhouse gas emissions [4, 16, 17, 19].

## 2. Material and Methods

Taking into account the energetic utilization, the examinations conducted with bioethanol were the basis for the subsequently designed, landfill gas utilizing, experimental Otto engine. In this case, both fuel types' stress-examinations can be conducted, but until this is done, we have to ensure the efficiency of the landfill gas's production.

Our three short-term tests were operated with commercial gasoline and two different bioethanol fuels (E85 Sample 1., E85 Sample 2.), and their 25%, 50%, 75% blends with gasoline to compare the IC engine behaviours by unchanged settings. The measuring apparatus contains— a Honda GX 160 type (one vertical cylinder, 160 ccm, four stroke, air cooled,) gasoline engine, equipped with Energotest-MMP-4 type electric-brake and a computer based control and evaluating system connected to it [3, 6] (Figure 1).

The test was based on three short-term runs operated with commercial gasoline (reference) and two different bioethanol fuels and their blends with the aim to compare the internal combustion engine behaviours by unchanged settings.

The engine test was made according to directives of ECE 24 standard, so the engine was fitted with the original intake and exhausting systems and these drove the moving parts. The measurements were made in 23 operating points between 1400 rpm and 3600 rpm. The values of torque (M) and the effective power (Peff) were measured in case of full throttle and fixed

dispenser lever position in every operating point. After selecting a given operating point the control of the measurement, together with the collection and the evaluation of the data are completely automated. (Energopower Software) [4, 6].

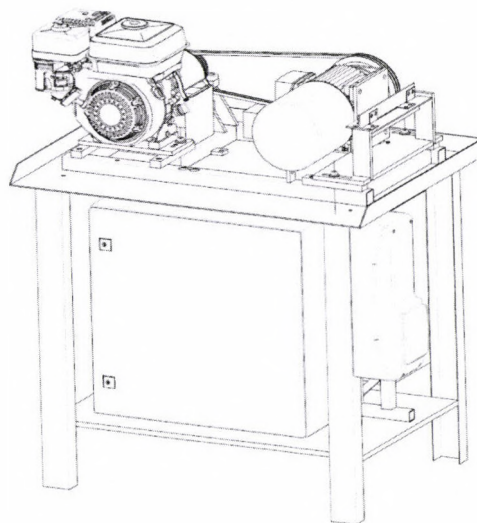

Figure 1. MMP-4 „Electric brake”

The elements of landfill gas extracting system are the following: gas wells, gas collecting pipes, gas controller unit, compressor unit, torch, container with gas engine, meteorological station. The collection of landfill gas is with the help of gas wells (Figure 2).

At the beginning there were low drainage gas wells used at the refuse dump but because of their sinking and deformation the effectiveness of gas extraction was impeded. They converted to upper drainage gas wells

which are only built after the dump is completely filled or reached a certain height. It does not interfere with the operation and good quality landfill gas is attainable [12, 13, 14, 15].

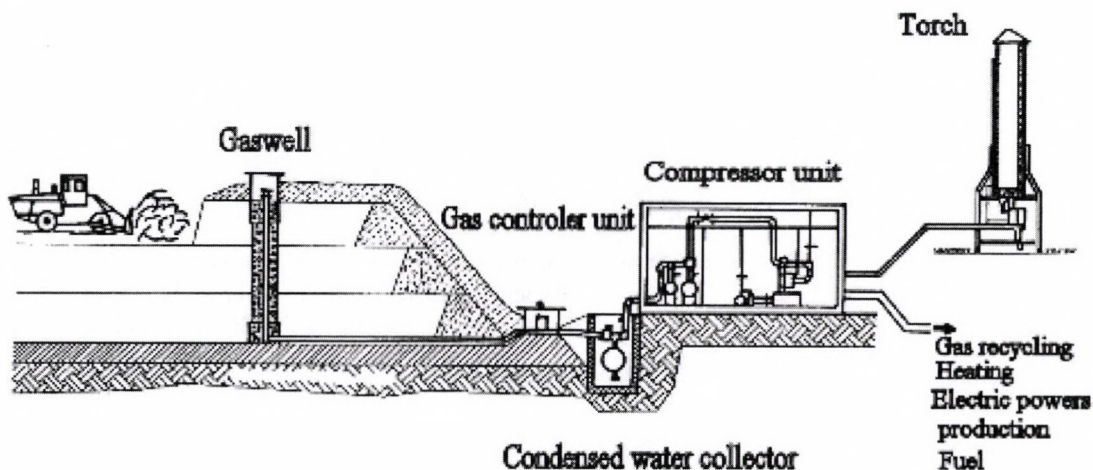

Figure 2. Process figure of gas production

At the communal solid waste refuse dump of the "A.S.A Hódmezővásárhely Köztisztasági Ltd." a computer data collection system and a measuring system is available to examine the quality and quantity of landfill gas. (Fig. 3.)

When preparing the measuring system three measuring points were established. Measuring point 2 is situated at the vacuum pump. Pressure values can be measured in front of and behind the pump, and thus the amount of the pressure difference can be calculated [12, 13]. From the pressure difference flow rate of the extracted landfill gas without pipe friction can be calculated and then, with the pipe diameter, the amount of the produced landfill gas. [9, 10, 11]

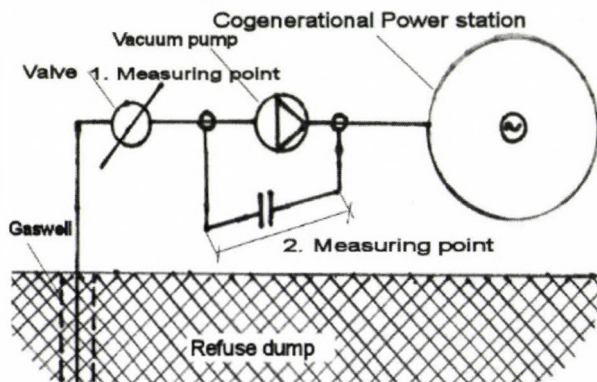

Figure 3. The location of measuring system at the refuse dump [7, 8, 9]

For diagnosing the degradation process in the refuse dump and optimizing energy recovery I we used a

GA2000 type NDIR (Non Dispersive Infra Red) analyzer, working in the medium infrared region.

The data was statistically processed with SPSS for Windows 11.0 program was used. The data was processed by the method of analysis of variance. Homogeneity was examined with the Levene-test. When comparing the group-couples Tamhane test (in case of heterogeneity), and LSD test (in case of homogeneity) were applied. The tightness between variables was determined by linear regression analysis. In our examinations we calculated the necessary number of data by using a method by [17].

### 3. Results

Deviations in the combustion behaviour and the functions of the engine control unit are quantifiable at the test bench. For the two bioethanol (E-85) fuels tested their torque and effective power parameters were less than the reference E-95 values. Figure 4 shows the relations between torque and fuel types and Figure 5 describes connections between effective power and fuel types. We established more less values in case of both parameters (less, than 50%), which can explain with lower calorific value (26,7 MJ/kg) and stoichiometric ratio (8,97) of bioethanols opposite gasoline' same parameters (43MJ/kg and 14.7). According to the measurements our statement is that as the bioethanol content increased the effective power and the torque reduced [3, 4] (Figure 6 and 7).

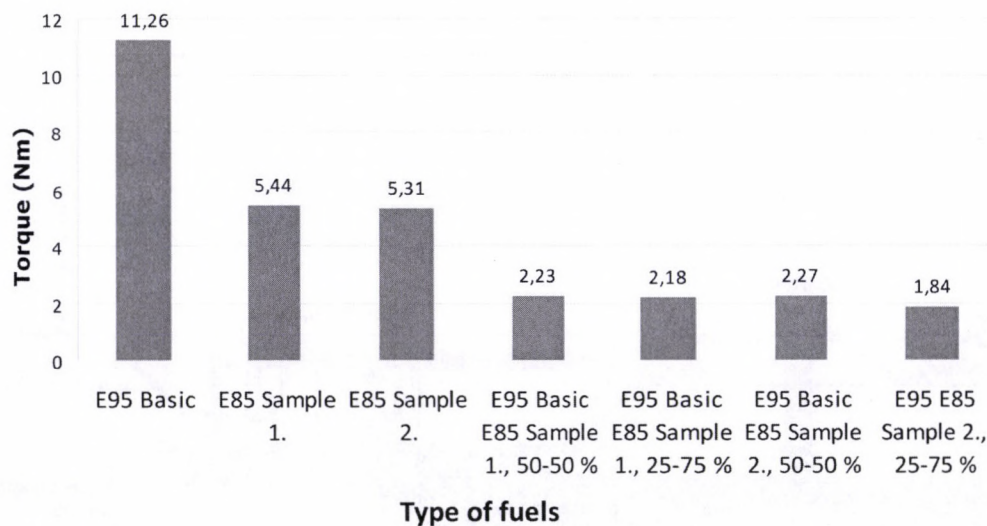

Figure 4. Relations between torque and fuel types

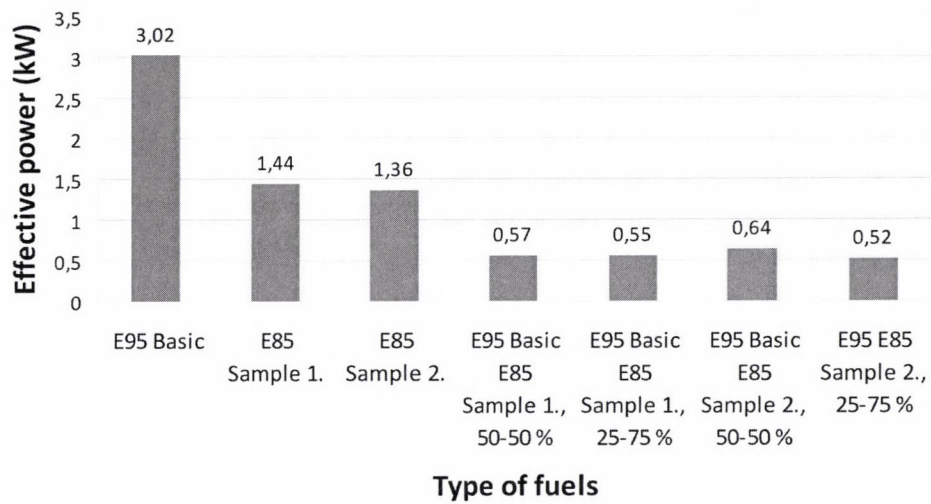

Figure 5. Connections between effective power and fuel types

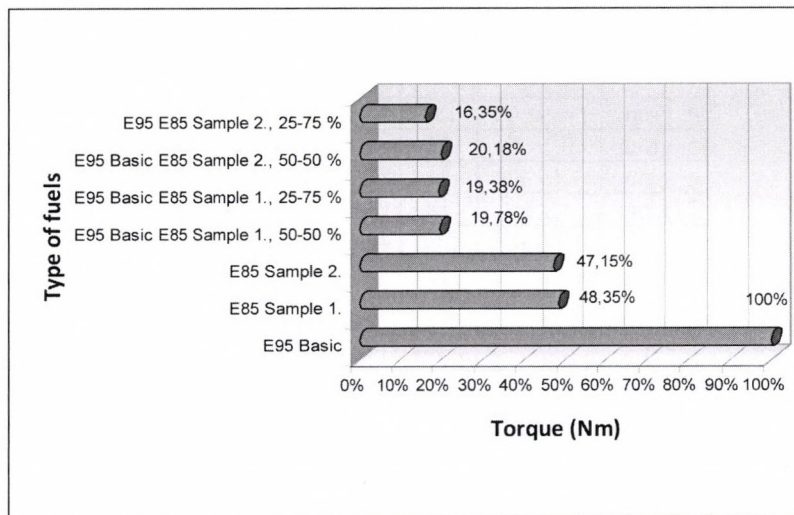

Figure 6. Changes between torque and fuel types

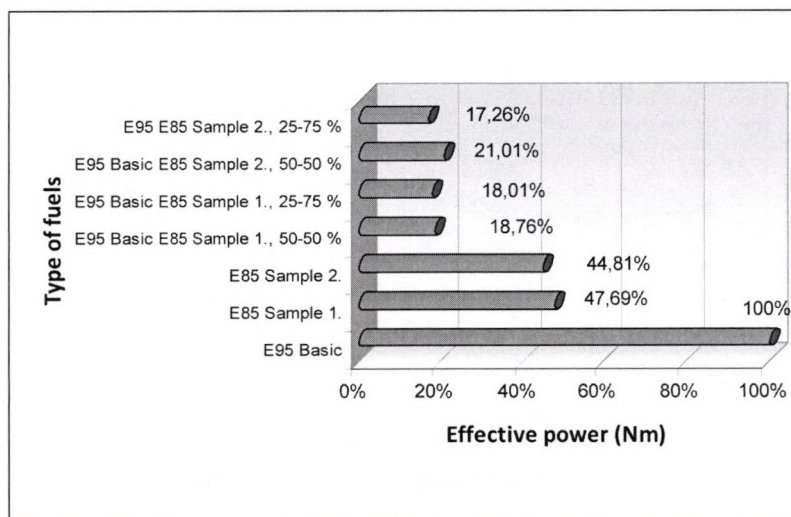

Figure 7. Changes between effective power and fuel types

*Changes of the quantity parameters of landfill gas with regard to the depression used*

In the first part of our examinations We tried to find a connection between the vacuum used and the methane content of landfill gas extracted from the refuse dump. Our results can be seen in Table 1. We took my measurements according to the barometric pressure by using a GA2000 landfill gas measuring device with regard to the environmental conditions of pressure. Minimum and maximum data are between

the rates of 1-68 CH<sub>4</sub>. In the group with the most elements in it ((-0,9)-0) we found 52,44% methane content. The worst rate, 43,34% methane content, was found in the 2nd group ((-2,9)-(-2)), in the 1st group with 45 measurements we found 45,47% methane content. As it can be seen from the results, in the cases of groups 4, 5 and 6 the average methane content is between 51,15-54,11% because of the vacuum used. In this case the applied rate of vacuum was between (-0,9)-1,9 mbar [20, 24].

Table 1. Results of the connections between the volume of extraction and methane content

Pressure group	Volume of extraction [mbar]	n [unit]	CH <sub>4</sub> mean [%]	Coefficient of variation CV% [%]	Std. dev. [%]
1. group	≤ (-3)	45	45,47	32,82	14,92
2. group	(-2,9) - (-2)	58	43,34	33,94	19,04
3. group	(-1,9) - (-1)	95	46,15	31,73	14,64
4. group	(-0,9) - 0	180	52,44	21,58	11,31
5. group	0,1 - 1	72	54,11	15,97	8,64
6. group	1,1 - 1,9	41	51,15	34,47	17,63
7. group	≥ 2	18	50,87	39,76	20,22
	Total	517	49,67	28,82	14,31

At gas wells where the extent of aspiration is over (-0,9 mbar) the larger vacuum the methane content lowers so the elements of the gas extraction system have to be under continuous observation (Fig.8). Standard deviation in the whole test range was s=14,319%, coefficient of variation value was changeable, CV%=28,82%. In the 4th group in the

measuring range with the highest number of elements ((-0,9)-0mbar) CV%=21,58% proved to be moderately volatile at 52,44% average methane content. In case of the 5th group in the 0.1-1 range CV%=15,97 because standard deviation is s=8,64% and the changes of minimum and maximum values show 31-68% of methane content.

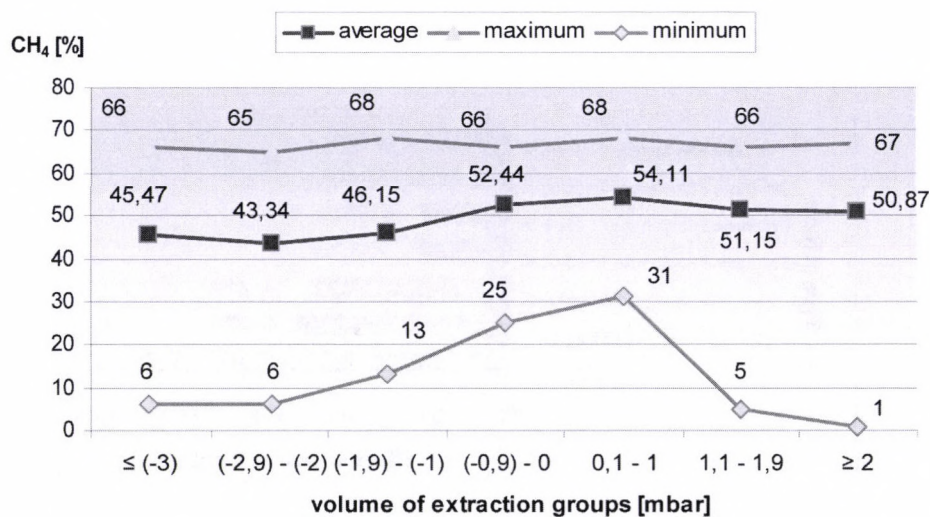

Figure 8. Results of the connection between aspiration groups and methane content

Analysis of variance proved significant results between the group pairs as the level of significance is  $P < 5\%$  for the examined parameters. In case of the homogeneity tests the samples showed heterogeneity so We use the Tamhane test. Results of the analysis between the groups can be seen in Table 2. The biggest difference is between group 5 (0.1-1) and group 2 ((-0.9)-0) the difference was 10,77% methane content. There was also a big difference between group 4 ((-0.9)-0) and group 2 (-2.9)-(-2) in this case

methane content difference was 9,11%. From the Table 2. you can see that the smallest difference, 0,29% methane content, is between group 6 (1.1-1.9) and group 7 ( $\geq 2$ ). There are significant differences between group 4 and group 2,  $P < 5\%$ , and the significant difference between group 3 and group 4 is  $P < 1\%$ . From the processed data we can conclude that under -0.9 mbar pressure there is no significant difference but in case of higher pressure methane content values get worse [23, 24, 25].

Table 2. Differences in the methane content of the examined groups and group pairs results

Pressure group	1. group $\leq (-3)$	2. group (-2,9)-(-2)	3. group (-1,9)-(-1)	4. group (-0,9)-0	5. group 0,1-1	6. group 1,1-1,9	7. group $\geq 2$
1. group	-	ns	ns	ns	*	ns	ns
2. group	2,13	-	ns	*	**	ns	ns
3. group	0,68	2,81	-	**	**	ns	ns
4. group	6,97	9,11	6,3	-	ns	ns	ns
5. group	8,63	10,77	7,96	1,66	-	ns	ns
6. group	5,68	7,82	5,01	1,29	2,95	-	ns
7. group	5,4	7,53	4,72	1,58	3,24	0,29	-

In case of all gas wells We carried out a linear regressive examination taking both methane content and volume of aspiration into account. Its results can be seen in Figure 9. Change of methane content in

relation to the vacuum used can be described by the following equation:  $y = 3,5607x + 51,72$ ,  $R^2 = 0,2644$ . Correlation coefficient is  $r = 0,52$ . The closeness of coherence shows a centralized correlation.

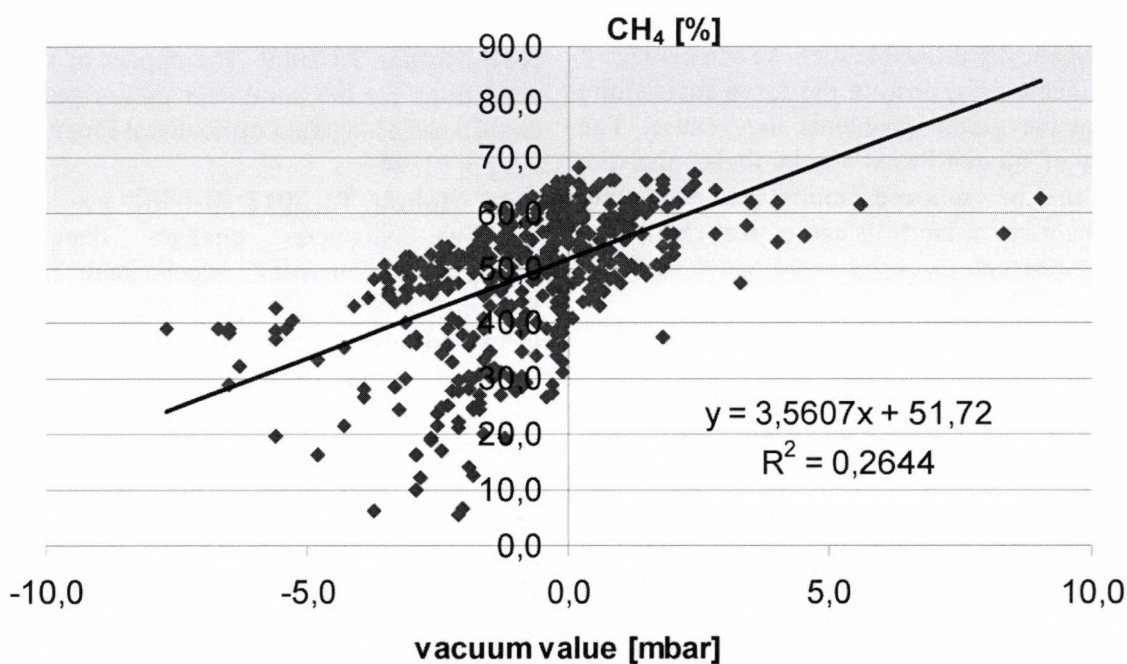

Figure 9. Changes of methane content in all gas wells in connection with volume of aspiration

## 5. Conclusion

Our three short-term tests were operated with commercial gasoline and two different bioethanol fuels (AGIP-E85, OIL-E85) and their blends with gasoline to compare the IC engine behaviours by unchanged settings. We'd recognised more less, than 50% values in case of torque and effective power, which can explain with lower calorific value (26,7MJ/kg) and stoichiometric ratio (8,97) of bioethanol fuels. We would like to continue our examinations testing the further percentage distribution of several blending bioethanol fuels. In accordance with literature the effective power and the torque grows as we decrease the bioethanol content in the fuels. [3, 4] Certainly by engine settings changes (e.g. ignition timing adjustment, increasing compression ratio, spark plug) we can further improved behaviour of our engine. We found that the operating parameters of the landfill gas extracting system used at the refuse dump has an effect on the changes of the methane content of the landfill gas. we determined the collection value according to the barometric pressure taking environmental pressure conditions into account. When the vacuum is higher than -0.9 mbar per gas well the methane content values significantly decrease. The relationship between vacuum values and the methane content of landfill gas shows  $r=0,52$  coefficient of correlation which indicates moderate closeness of relationships.

The results of the bioethanol and landfill gas experiments show something interesting. From the agricultural sector's main products and the communal sector's waste, through biological means, we may obtain energetically utilizable fuel. We can manage it in a sustainable way, despite the fossil fuels finite nature and the global problems they cause. The utilization of biogen-based liquid fuels, also the increase in the mixture ratios and reducing Greenhouse gases at landfills cause great challenges and require research.

## References

- [1.] **Demirbas A.:** 2009. Progress and recent trends in biodiesel fuels. *Energy Conversion and Management*, Vol. 50. pp. 14-34.  
<http://dx.doi.org/10.1016/j.enconman.2008.09.001>
- [2.] **Demirbas A., Demirbas I.:** 2007. Importance of rural bioenergy for developing countries. *Energy Conversion and Management*, Vol. 48. pp. 2386-98.  
<http://dx.doi.org/10.1016/j.enconman.2007.03.005>
- [3.] **Bilgin A., Durgun O., Sahin Z.:** 2002. The effects of diesel-ethanol blends on diesel engine performance. *Energy Sources*, Vol. 24. pp. 431-440.  
<http://dx.doi.org/10.1080/00908310252889933>
- [4.] **Nagai K., Seko T.:** 2000. Trends of motor fuel quality in Japan. *JSAE Rev.* Vol. 21. pp. 457-62.  
[http://dx.doi.org/10.1016/S0389-4304\(00\)00070-9](http://dx.doi.org/10.1016/S0389-4304(00)00070-9)
- [5.] **Speidel H. K., Lightner R. L., Ahmed I.:** 2000. Biodegradability of new engineered fuels compared to conventional petroleum fuels and alternative fuels in current use. *Applied Biochemistry and Biotechnology*, Vol. 84-86 pp. 879-897.  
[http://dx.doi.org/10.1007/978-1-4612-1392-5\\_69](http://dx.doi.org/10.1007/978-1-4612-1392-5_69)
- [6.] **He Y., Bao Y. D.:** 2003. Study on rapeseed oil as alternative fuel for a single-cylinder diesel engine. *Renewable Energy*, Vol. 28. pp. 1447-1453.  
[http://dx.doi.org/10.1016/S0960-1481\(02\)00223-9](http://dx.doi.org/10.1016/S0960-1481(02)00223-9)
- [7.] **Bai A. (ed.):** 2007. A biogáz. Száz Magyar Falu Könyvesháza Kht. ISBN: 978 963 7024 30 6. Budapest, pp. 284
- [8.] **Bai A.:** 2015. Helyi közlekedés és hulladékgazdálkodás. *Magyar Energetika* Vol. 22. Issue 1. pp. 21-25.
- [9.] **Christensen T. H. H., Kjeldsen P.:** 1989. Basic biochemical process in landfills Sanitary Landfilling (ed.: Christensen, T. H. H., Cossu R., Stegmann R.) Academic Press, pp. 29-48.
- [10.] **Hódi J.:** 2009. Depóniagáz kutak problémái, megoldási lehetőségek XIX. Nemzetközi Köztisztasági Szakmai Fórum, Szombathely, április 21-23.
- [11.] **Loll U.:** 2001. Biogaspotenziale im Klärschlamm und anderen biogenen Abfällen, KA Wasserwirtschaft, Abwasser, Abfall, Vol. 48. Issue. 10. pp. 1424-1429.
- [12.] **Molnár T.:** 2007. Quantitative and qualitative analysis of the biogas production from the municipal solid waste, *Hungarian Agricultural Engineering*, Vol. 20. pp. 20-22.
- [13.] **Molnár T.:** 2009. The impact of the weather conditions for the parameter of the production of landfill gas, *Hungarian Agricultural Engineering*, Vol. 22. pp. 91-94.
- [14.] **Molnár T.:** 2012. Landfill gas quality and quantity parameter changes depending on precipitation intensity. *Mechanical Engineering Letters*, Vol. 8. Issue 2. pp. 90-97.
- [15.] **Molnár T.:** 2008. Landfill gas composition analysis. 50th Jubilee Georgikon Scientific Conference, Keszthely, 25-26th of September, pp. 165, ISBN: 978-963-9639-31-7.
- [16.] **Nagy V., Farkas F.:** 2012. Exhaust gas tests using of biofuels in IC engines, *Hungarian Agricultural Engineering*, Vol. 24. pp. 49-52.
- [17.] **Sváb J.** 1981. Biometriai módszerek a kutatásban, Mezőgazdasági Kiadó, Budapest ISBN: 9632310136, pp. 50-51.
- [18.] **Sembery P., Tóth L.:** 2004. Hagyományos és megújuló energiák, Szaktudás Kiadó, Budapest, pp. 274-279.

- [19.] **Stachowitz W. H.:** 2004. „Berechnung“ oder Abschätzungen von Gasproduktionsmengen Gasprognose
- [20.] **Stachowitz W. H.:** 2005. Grundlagen der Fassung und Entsorgung von Deponiegas, DAS – IB GmbH Stand: Juli 2005.
- [21.] **Péter Sz. I., Szabó G.:** 2013. Study of The Efficiency And Other Working Parameters Of Solar Collectors. Acta Technica Corviniensis, Bulletin of Engineering, Vol. 6. Issue 1. pp. 143-145.
- [22.] **Péter Sz. I., Szabó G.:** 2012. Development Of Data Processing Algorithm For The Recognition And Correction Of Measuring Errors Occured During The Test Of Solar Collectors. Annals of Faculty Engineering Hunedoara, ISSN: 1584-2665.
- [23.] **Tóth L.:** 2012. Alternatív energiaellátási rendszerek az agrárgazdaságban, Magyar Agrárkamara, Szaktudás Kiadó Ház, Budapest, pp. 235. ISBN: 978-615-5224-22-5.
- [24.] **Tabasaran O.:** 1981. Gas production from landfill. In: Bridgewater AV, Lidgren K, editors. Household waste management in Europe, economics and techniques. New York: Van Nostrand Reinhold Co.; 1981. pp. 159–175.
- [25.] **Woperáné S. Á., Tanka S.:** 2011. Hulladéklerakóban keletkező biogáz hasznosítása, Miskolci Egyetem, Tüzeléstan és Hőenergia Intézeti Tanszék, Anyagmérnöki Tudományok, Miskolc, Vol. 36. Issue 1. pp. 79–90.