

THE SUSTAINABILITY AND USAGE EFFICIENCY OF CONVECTIONAL GEOTHERMIC ENERGY PRODUCTION

Author(s):

J. Nagygál – L. Tóth

Affiliation:

Szent István University, Faculty Mechanical Engineering, Páter K. street 1., H-2100 Gödöllő, Hungary

Email address:

nagygj@arpad.hu, toth.laszlo@gek.szie.hu

Abstract

The use of geothermal energy in Hungary has decades of history, most notably in the area of direct usage. In the last ten years, both experts and the common people got to know this technology due to the disadvantageous legal changes. Most of the domestic energetic users are involved in agriculture. Extracting and using energy, different technologies, and the location of water are all different scientific areas. The entire system's success is based on the inter-disciplinary relations of many scientific scopes and sciences. The cooperation of the most notable practitioners of various sciences, professors, building engineers, architects, geologists, geophysicists, drilling engineers can mean the development of the sector, and the efficient solution for the problems which come with it.

In our study, we tried to find the answer to a sustainable thermal water production's most efficient method by analysing 20 currently operating thermal water wells, and did not forget to make use of the heat extracted, and the final water placement. During my work, I placed importance on getting to know the connections between thermal water and geology, on mapping the geological conditions, and on knowing the questions of digging wells. All these together make it possible to create a pre-plannable drilling, training, production and usage system's creation, which can adequately handle both ecological and economical questions. The geothermal fluid produced has to be placed somewhere, which was a question of faith for a long time. This was also further influenced by how the experts were never capable of sitting down, and conducts a discussion using actual facts and reasons. As the users cannot be expected to develop refilling techniques, it falls on the experts to plan and parameter a well construction which poses small drilling and management risks.

Keywords

Geothermal energy, renewable energy, usage efficiency

1. Introduction

The geothermic gradient of Hungary is significantly above the world average, which is why there is a notable potential

in the usage of geothermal energy. Which is already widespread method of heating in some areas (f. e. gardening, living quarters, thermal baths) of Hungary. Apart from the direct costs of digging of wells and refilling water, the most notable problem is posed by the establishment of facilities due to the costs of creating the entire system.

Thermal water without any kind of modification can be used to transport thermal energy, and to exchange it either in a direct, or in an indirect way. The operation costs of the thermal well are low when compared to the harvestable thermal energy, which is why the heating based on thermal water has strong competitiveness when compared to other methods. It is advantageous that it's in reach in our country's areas dealing in agriculture - mostly flatlands. The thermal energy can be produced locally, and there is no need to transport, it does not depend on import, season, time of day or weather conditions [1, 2].

It is a fundamental goal to use this national treasure in an environmentally friendly and sustainable manner.

Goals

The goal of this study is to highlight connections which have to be analysed in order to assure that currently used excavation and usage technological solutions are sustainable in the long-term.

1. Checking the production parameters of the thermal wells near Szentes. The detailed analysis of twenty thermal wells situated upon sandstone deposits, and the results of the in situ measurements are used to check the water level compared to ground level. The research of the conditions related to the check.
2. Overview of the current domestic experiences amassed related to refilling. Deducing if there is a "fluid layer exchange" between the water yielding layers during the wells' rest period. We have to determine if the monitoring well works properly, that proves the adequate state of the layers yielding and absorbing the water, opened and filtered for the planning of refilling. Does the low tide influences the measurement results.

3. Checking if greenhouse heating is economically profitable using energy procured from geothermal fluid, and comparing it to energy resources in use, in light of current market prices.
4. Heat pumping the fluid of lower enthalpy before refilling, and determining if the procured excess energy compensates for the costs of the heat pump, and the new well pair's digging and management. Based on the current CO₂ emission of the current electricity production, what COP value is needed by natural gas heating for an advantageous effect.
5. Does the buffer container installed in greenhouses' heating systems aid the production?

2. Material and Method

Unique well inspections

In order to get to know the data of the well, we have to do a well inspection. The measurement of the wells happens

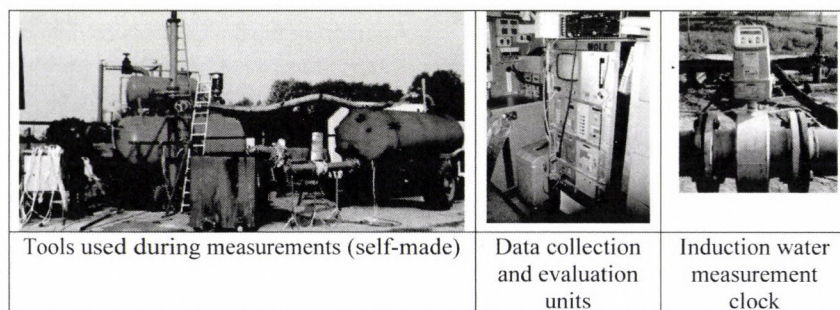

Figure 1. Surface measurements

The reference point for depth attributes was the ground level, which can be considered constant.

Measured attributes:

1. water level and well pressure
2. air pressure
3. temperature of water flowing out
4. gas content (with sampling)
5. water yield

Water level and well pressure

In order to conduct the unique well inspections, both in its resting and operational time, the individual, long-term data recording Levelogger pressure- and temperature measurement unit was used. During the analysis of the cross-effects, multiple wells were watched at the same time, which was done with MicroDiver water level measurement units, which have similar attributes and operational method. The Levelogger and MicroDiver water level measurement units were not used to measure water level, but pressure, and they recalculate it to water height. Analogue manometers always measure water pressure compared to air pressure. The values measured by the pressure units watched two values: the pressure of the water above the unit, and the air pressure. The two combined gives us the absolute pressure as follows:

$$p = p_{\text{water}} + p_{\text{air}} \quad (1)$$

with static and dynamic analyses [3]. The static measurement happens when the well does not produce, in a way that the well is freed of all machinery required for its usual operations. During the dynamic measurement, the well is operated with a compressor or a diving pump according to its operational parameters (Figure 1). The samplings are done after the well reaches its operational temperature. The machinery used for measurements are:

- Well consistence check, static analyses
- Dynamic analyses
- Samplings, laboratory analyses

In order to calculate the pressure of the water, air pressure has to be subtracted from the absolute pressure.

Air pressure measurement

In order to collect the calculations with air pressure, Barologger was used as a data source. Gas separation, gas yield calculation During the well inspection measurements, we have to separate gases, as gas phase falsifies the data of water measurement clocks, but the calculation of this is also necessary in order to determine gas yield and gas composition. The fluid was first lead into the separator container, where the gas evaporates from the water. The gas leaving the water via the top of the container has to be cooled down for dew to manifest. The cold gas is usable for correct measurement by membrane and turbine gas measurement clocks.

Yield measurement

The water flowed from the separator containers through the water measurement clock attached to the data collection unit. This high salt-content fluid is refilled into the network via pumps.

Temperature measurement of the water flowing out

A Pt100-type temperature measurement unit was built into the pipes after the separator container, while the data were registered by the LogBox data collector.

Structural analysis of the wells

This type of measurement is a natural gamma, diameter and temperature measurement conducted via a combined unit within the closed well.

Data discovered:

- accessible base depth,
- piping diameters,
- stack exchanges,
- locations and closure of sealing,
- locations of opened areas,
- and the quality of cement works in the circular areas.

The natural gamma tunnel made it possible to check the cross-drive layer row (differentiate between permeable - impermeable areas), which is how we can check if the opened areas are capable of yielding water, and to determine where covered pipe clams are.

Flow profile

These measurements were conducted with the combined FRTmOP unit (flow, temperature, fluid resistance, optical transparency and pressure measurement unit). In the case of depth-based calculations, the unit moves in the well, and registers the data in 10 cm sampling increments, thereby pressure gradient and flow measurements determining the active areas of the filters can be conducted. The recorded pressure data is used to calculate gradient, which is in proportion to the density of the context, it's role is to show the bubbling point. Measured data was corrected by the temperature values.

Time-based depth pressure and temperature measurements

In order to conduct the depth pressure measurement - during the unique well inspections - the FTRMOP acoustic units were used, which sends the depth data real-time through a cable.

Organising measurements

The "timetable" set up for the analyses: building the pumps, static analyses, structural analysis of the well, rebuilding the well for compressor-aided production, building the lubricator, building the water measurement system, building the refilling unit, installing the compressor, prior production (24-48 hours), dynamic analyses.

Effects of the low tide

We analysed data measured by high-definition measurement tools, by taking the moon phase into consideration. Technically, we looked for the pulsating production change's effects of the active well and the pressure changes via the inspection well.

Possible agricultural heating systems, and comparison with geothermal heating

In Hungary, winter production is impossible without greenhouses. In practice, there are various energy resources, but due to the economic parameters, only a few can actually be realised [4].

Combustion heat production:

- firewood, wood chips
- pellet
- coal
- natural gas or PB gas

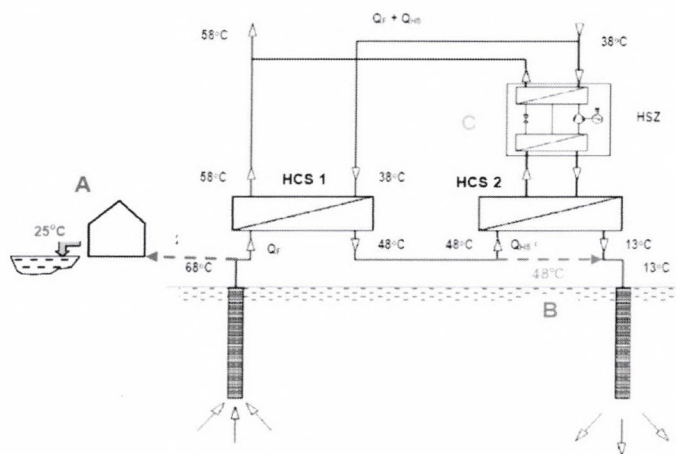

Figure 2. Options of using thermal water [6]

- A= direct heating coming from the well with the thermal water, leading the cooled (f. e. 25 °C) into a resting lake
- B= leading the thermal water coming from the well into a heat exchanger (HCS-1), and refilling the less hot (f. e. 48 °C) water, cooler due to the extracted heat
- C= leading the thermal water coming from the well into a heat exchanger (HCS-1), and leading the less hot (f. e. 48 °C) water into a heat exchanger (HCS-2), heat pumping it, then refilling the cooled (f. e. 13 °C) water, and leading the extracted heat into the heating system.

–heating oil.

Without combustion:

–heat production from thermal water.

Using heat from the environment with energy aid (electricity, natural gas, pyrolysis gas):

–heat pumping (air-air, soil-air, or used water-air).

In practice, we calculate heat requirement as follows:

$$Q = K' (t_b - t_k) F_{\text{ü}} \quad (2)$$

Based on the data received from the designers and the managers, and the offers from the websites, we determined the costs of the various heating systems for 1600 kW heat performance requirement. We did similarly when calculating the fuels' costs.

Greenhouse development for sustainability

Placing thermal water above ground causes environmental problems due to its high salt content, which is why there is an environmental load fee. Refilling it into the water yielding layer causes problems due to the drinking water base, but those can be solved, and the usage will be compulsory due to sustainability reasons [5]. In any case, refilling is an option, while another one is placement above ground after using heat pumping to extract the thermal energy from the high enthalpy fluid (Figure 2).

Thereby, the total amount of heat extracted: where:

$$Q_{FC} = \dot{m}c(T_{fo} - T_{fh}) \frac{\varepsilon_f}{\varepsilon_f - 1} \quad (3)$$

T_{fo} = average temperature of the leaving (for heating) water (K),

T_{fh} = average temperature of the fluid lead into the heat pump (K).

Our heating system is efficient exergetically if we use exactly as much exergy as we need. In practice, we have to carefully select the heat pump for this.

Measurement results in the buffer container

The heating systems of greenhouses have to constantly substitute for the heat exchanged into the environment through the material of the greenhouse and the ventilation [7]. If the greenhouses' structure is homogeneous in 90-95%, and the heat leaving through it (Q_o) and the heat leaving through it is considered a base heat loss, then we can calculate from the heat exchanging surfaces' heat loss:

$$Q_o = A_h \cdot k_o (t_i - t_e), \quad [W \cdot m^{-2} \cdot K^{-1}] \quad (4)$$

where:

– A_h – surface area of the greenhouse [m^2],

– k_o – heat permeability of the greenhouse's surface area [$W \cdot m^{-2} \cdot K^{-1}$],

– t_i – internal temperature of the greenhouse [$^{\circ}C$],

– t_e – external temperature of the greenhouse [$^{\circ}C$].

We measured the mass flow and temperature of the water flowing into the container in three time intervals, and the environment's and the greenhouse's average temperature (Figure 3). The data is required to determine the container's capacity.

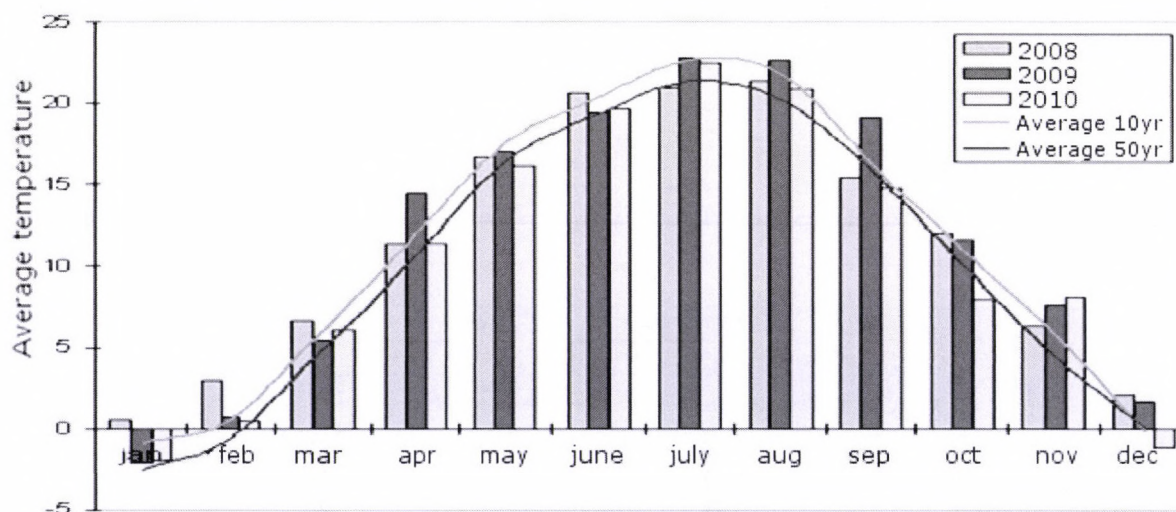

Figure 3. The monthly temperature average for a year around Szentes

3. Results

Geological and hydro-geological conditions, attributes of the area in question, details of the layers

As the depth increases, so does the pressure. In the upper Pannon's lower area, the hydrostatic pressure is about 40 meters below the potentiometric level (Figure 4).

In order to determine the regional hydro-dynamic attributes of the wells in question, the cross-effects and capacity analysis and refill measurement of the 3. well of the Árpád VII well group was applicable. The essence of this is the data from the inspection wells, during the well's operations. The various (numbered 14) but inter-connected wells yield more water as the base depth increases (Figure 5).

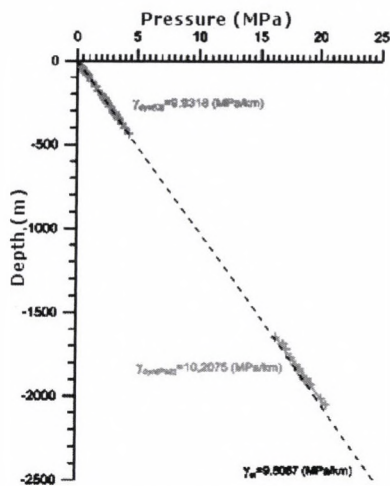

Figure 4. Pressure and depth data of the wells of Szentes

Determining the connections of water exchange between layers

Currently, there are 34 thermal water wells in the region around Szentes, of these, I analysed and modelled 20 currently operating wells (Table 1). The ground formation consists of sandstone, aleurolite and clay limestone, most of which is sandstone. The channel filling and aber reef deposits dominate, which have a good containing capacity, and limited horizontal spread, but the multiple avulsions and overlays are connected from a hydro-dynamic perspective. Therefore, many 5-25 metres sandy layers with good flow permeability change with clay-aleurite formations with bad permeability, as f. e. the acoustic logs from around Szentes also prove (Figures 6-7).

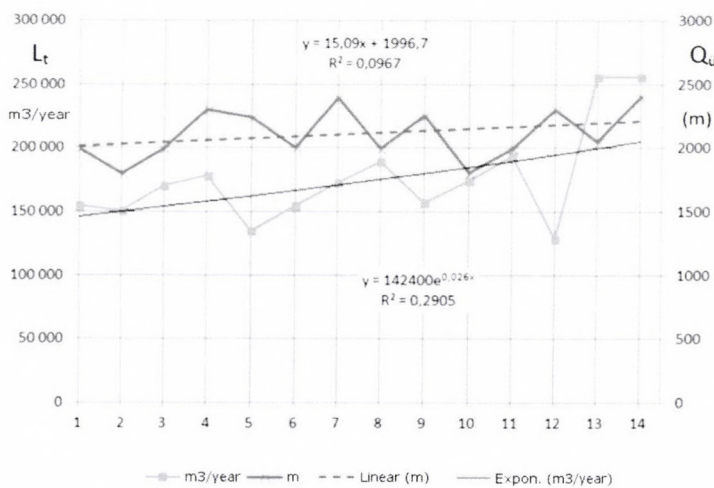

Figure 5. The connection between the wells' depths (L_t) and yield (Q_u)

Table 1. Average data of 20 wells from Szegvár and Szentes

	Base depth	Filtering (lower)	Filtering (upper)	Q max.	Water temperature
	(m)	(m)	(m)	(l/min)	(°C)
Average	2165,4	1873,75	2119,1	1488,45	86,5
Deviation	236,0	175,6	227,2	370,2	7,7

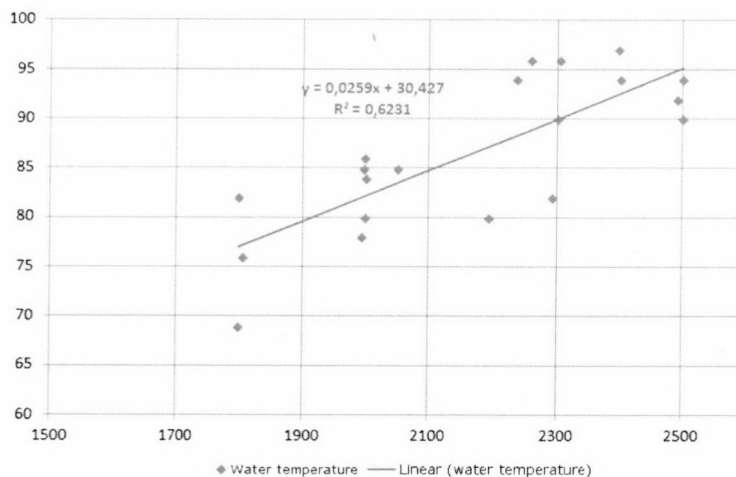

Figure 6. Connection between base depth (m) and water temperature

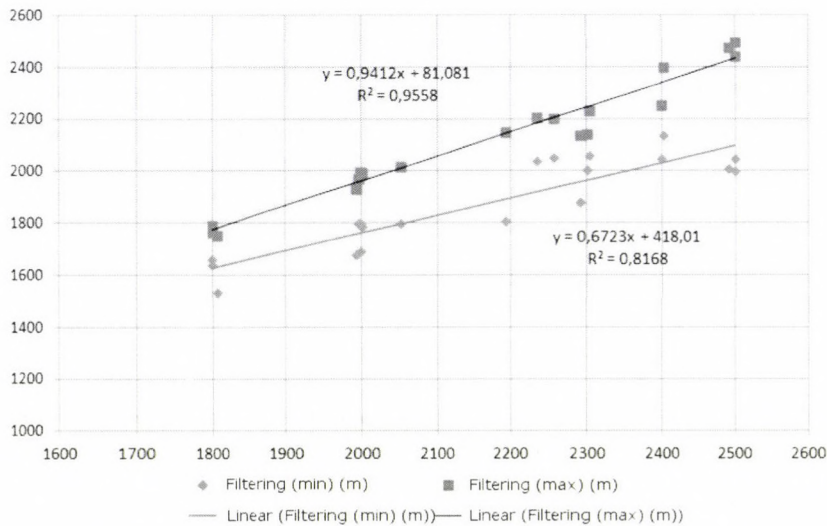

Figure 7. Connection between filtering max and min, and base depth (m)

Figure 8 contains a visual representation of the data gained from two wells of Szentes, made in order to find connections. The data set is as follows:

- natural gamma log (red)
- flow measurement curve (black)
- filtered areas (purple)
- non-reachable well areas (grey)
- active areas (green)
- route of cross-filling (black arrows)
- base of reachable areas (yellow)
- geothermic gradient's calculated reciprocal (on the bottom)

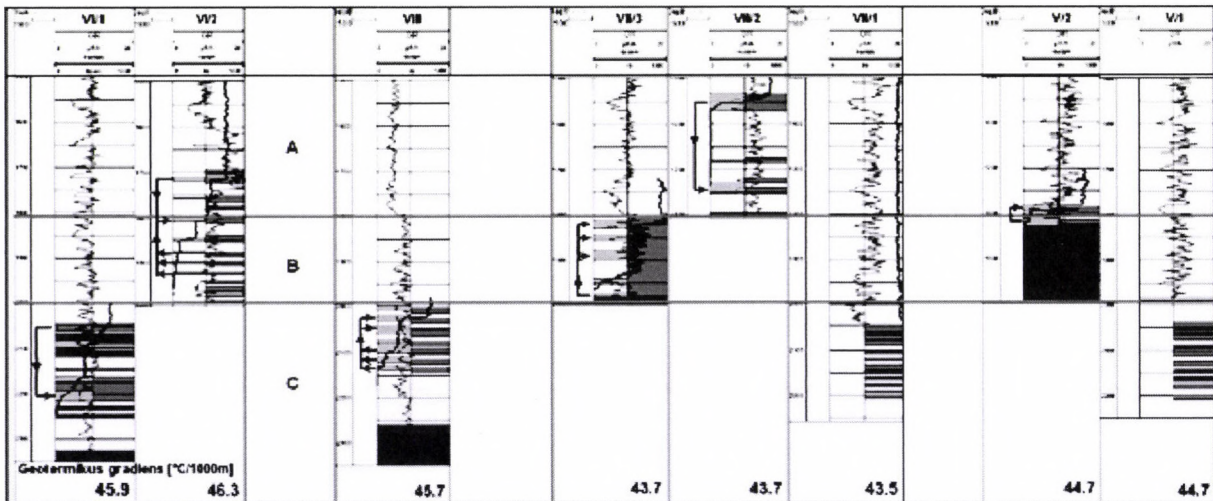

Figure 8. Internal cross-fillings between filtered layers within the wells of Szentes (for group I)

Illustrating the measurements conducted in the wells, and detailed analysis (we merely illustrate the attributes observed for the various wells):

Markings:

- blue curve – temperature log measured in the closed well
- red curve – temperature log measured during production
- blue curve upper – flow measurement log
- red columns – active filters
- blue arrows – internal water flow's route in closed wells
- above the figures: temperature gradient (green line)

In the example on Figure 8, all filters produce in the closed well. Areas I and II (from top to bottom) produce, but the water is drained into areas III, and mainly IV. It is important

to note that filters VI and V also produce in a closed situation towards area IV, as much as during operation.

According to the evaluations, we determined that [8]:

- temperature gradients match for the wells close to each other
- among the gradients, we can identify area differences
- the routes of cross-fillings are varied, in many wells, the cross-filling happens towards the middle layer from both the top and bottom layers
- the routes of cross-feedings give useful information about the pressure conditions of the yielding layers, which should be taken into consideration for both well production planning and new well planning

–when planning a refilling well, it is important to know the location and temperature of the absorbing layer, and the route of cross-filling.

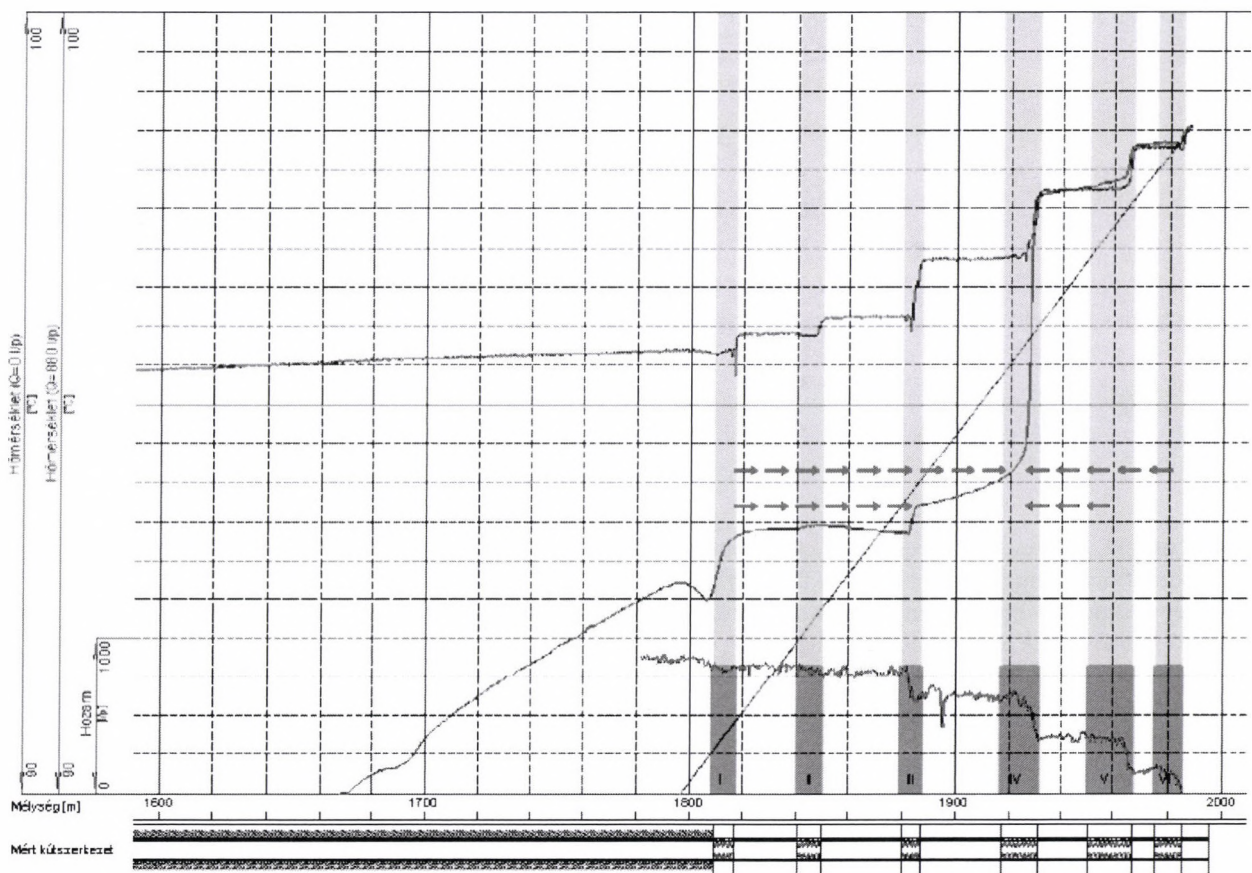

Figure 9. Szentés, Árpád-Agrár Co. Ltd., thermal well I (2000m), calculated geothermic gradient is 44,9 [°C/1000m]
A two-way flow was created

In wells which have multiple filters, cross-feeding and the absorption of some layers can always be observed, which means refilling can theoretically be realised always, to some degree at least (Figure 9). These analyses helped me get familiar with the area's hydro-geological attributes, and the more concrete technical and hydro-dynamic parameters of the wells in operation.

Low tide's effect on the measurements of thermal wells

During the calculations, using high-definition units in the inspection well showed the pulsating production changes' effect in the active well. The Moon caused the greatest effect when in line with the Sun during the analyses, which were the phases of New moon on 8. September, 2010, and Full moon, on 23. September, 2010. Of the two dates, the registered time of our analyses includes the New moon date. If we highlight a 12-hour from the periodic changes, we can observe the state seen on Figure 10.

The average process of this 12-hour pressure change can be seen on Figure 11. The trend shows a parabolic connection ($R^2 = 0,8519$).

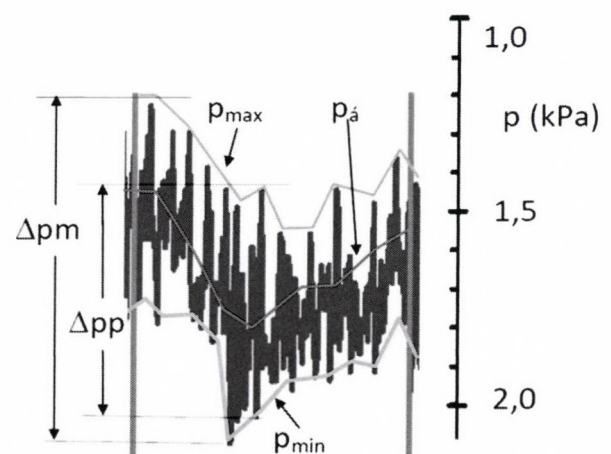

Figure 10. Maximum, minimum and average values' changes during the 12 hour period
 Δp_m = max change in 12 hours
 Δp_p = 0,6 kPa change during an hour
 $\Delta p_á$ = 0,35 kPa highest change of the average of 12 hours

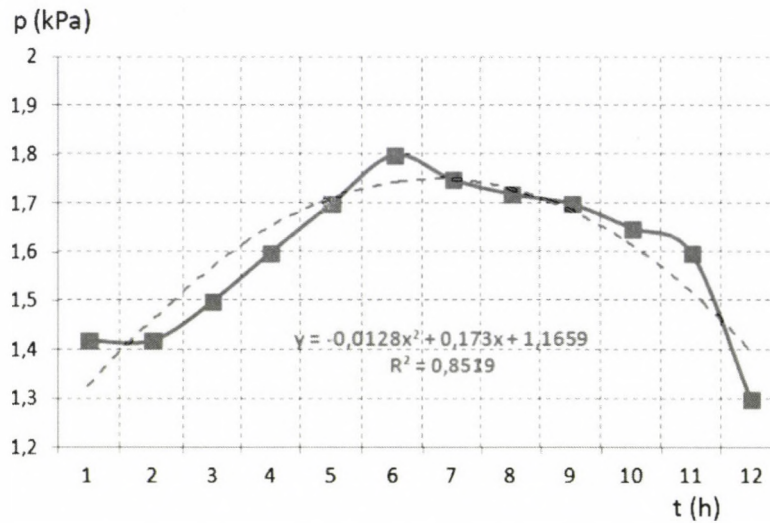

Figure 11. Average process of 12-hour pressure decrease

Based on the measurement results, we can state that if certain conditions are met, the positions of the Sun and the Moon can influence the rest and operation water level values of subterranean water bodies – the wells, in our case. During the analyses, the changes of water level show a 70 cm monthly, and ~15 cm daily in a cycle, even without any influencing factors.

Comparison of possible agricultural heating systems and the geothermal heating

As the heating requirements can change for any national areas due to different external factors, the values taken

from charts cannot be used in general for any area, and are mostly usable for comparison. When determining the prices of energy resources, we relied on the average value of prices for Hungarian industrial users. When determining the prices of machinery, we aimed to select those of good quality and price to value ratio.

As we can see on the data of Figure 12, the most advantageous is the thermal well heating system, followed by coal and lignite, and heat pumping in 4.th place. The calculation is applicable to the given situation, but the heat pumping systems have a determining effect when looking at the heat considered waste.

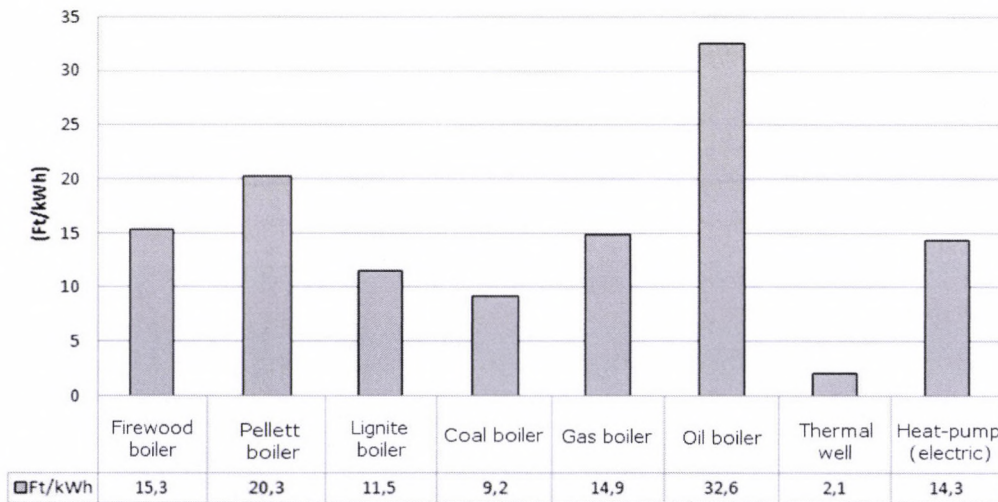

Figure 12. Total price of 1,0 kWh heat for a 15 year return on the system [9]

Greenhouse development for sustainability

Usage, economic benefits and environmental questions of using a heat pump

Using the most modern, large airspace greenhouses, the most developed construction techniques, and the best

technical solutions, experts forecast a huge leap in the sector's development. In modern agricultural production systems, geothermal fluids' energy content is used in multiple steps, and they do not forget to take sustainability into consideration either (Figure 13).

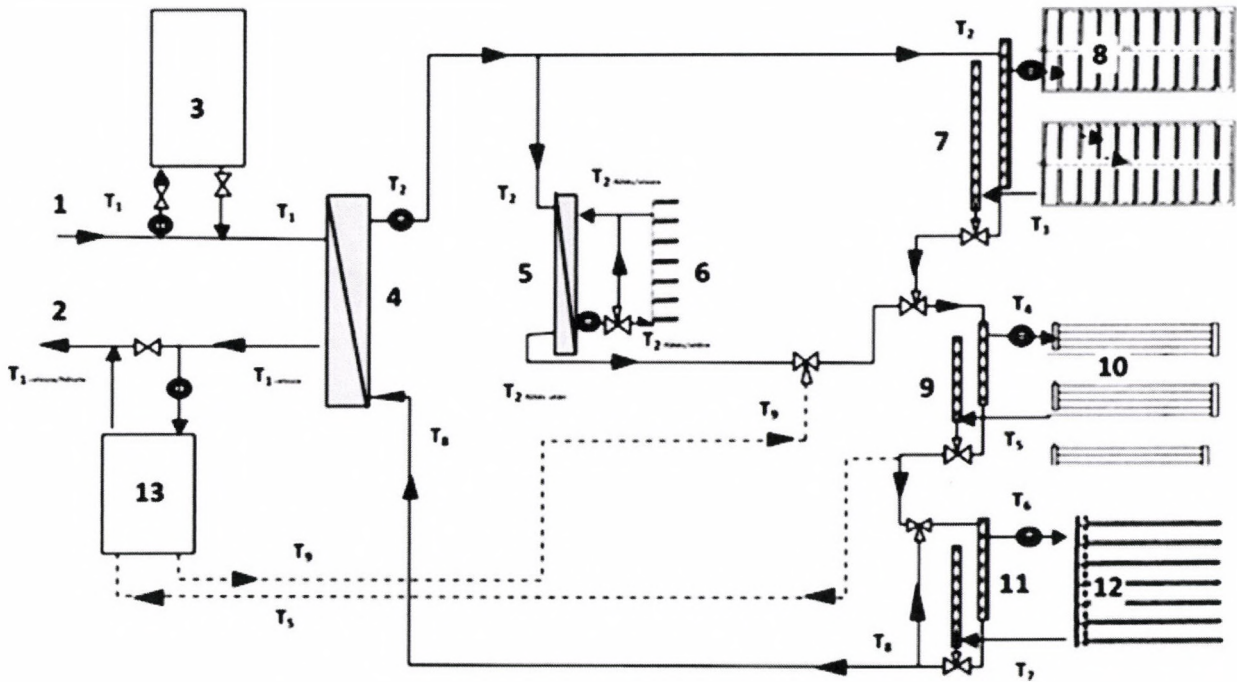

Figure 13. Theoretical heating system of a modern greenhouse [3]

Signs on the figure: 1 – production well, 2 – absorbing well, 3 – buffer container, 4 – main flow heat exchanger / heat centre, 5 – heat exchanger of social buildings, 6 – heating of social building, 7 – spread-collect units of vegetation heating, 8 – vegetation heating, 9 – spread-collect units of bloom heating, 10 – bloom heating, 11 – spread-collect units of soil heating, 12 – soil heating, 13 – heat pump

The heat performance obtainable via the heat pump is related to the mass flow and the ΔT value at the heat exchanger (temperature difference between inbound and outbound fluid):

Case A

$$Q_{FA} = \dot{m}c(T_{68} - T_{25}) \quad (5)$$

Case B

$$Q_{FB} = \dot{m}c(T_{68} - T_{48}) \quad (6)$$

Case C – via heat pump

$$Q_{FC} = \dot{m}c(T_{48} - T_{13}) \frac{\varepsilon_f}{\varepsilon_f - 1} \quad (7)$$

Case B and C combined:

$$Q_{F(C-B)} = Q_{FB} + Q_{FC} \quad (8)$$

If we take a look at the above, we can say that heat pumping before either refilling or letting the water off can produce energy close to 60-80% of the energy coming from direct usage. If we calculate properly, this energy, and the costs of using heat pumping has to be compared to the investment costs of a new pair of wells, and in the case of

letting the water off, the environmental load fee. The calculation shows positive results even for a new well. This system is especially advantageous in case we increase the plantation, and the energy requirement increases too, but we do not want to make a new geothermal investment.

In summary: in places, where refilling can be realised without problems, the system has a competitive edge against direct heat extraction using a new pair of wells. The heat pump serves sustainability best if assisted with renewable-source electricity. Figure 14 below shows an exergy-based analysis of a heating system including a heat pump. In the T diagram, to make sure we get T_v temperature, the required heat is signified by points 1-2-7-8. In the environment, we have the amount of heat signified by points 3-4-7-8. From the perspective of exergetics, if the reference temperature equals the environmental temperature, area 1-2-3-4 (which can be gotten by subtracting the V_2 loss) is the efficiently used energy (Ex). The temperature of vegetation heating (T_5) (heat amount) is aided from the secondary (condensation) side of the heat pump, which is subtracted from the heat not let out towards the environment. On the figure, the two areas of 3-4-7-8 and a-b-9-10 are equal (naturally, if we include losses, the latter is bigger). The exergy content (a-b-c-d) of this equals the heating requirement of vegetation heating. Our heating system is efficient exergetically, in case we use as much exergy as we require. In practice, we have to carefully choose the heat pump for this.

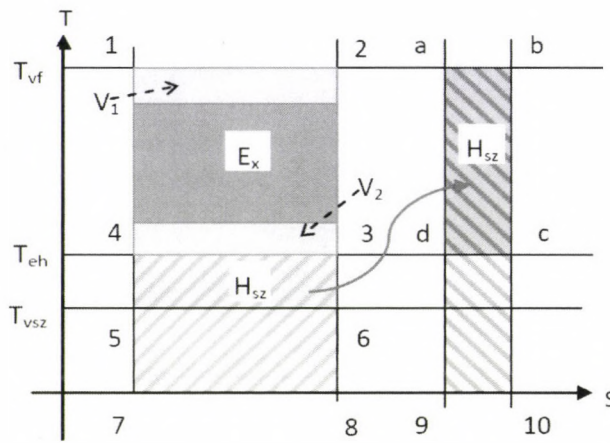

Figure 14. The exergy of the system increases by using the heat pump

In conclusion, using a heat pump increases the exergy in the system, and the heating water is substantially different in its attributes from the environment. This persists for both the internal and the external environments, but it's important that in the more critical winter season, it has a higher exergy content than on a hot summer day.

Buffer container measurement results

The heating systems of greenhouses have to complement the heat which the greenhouse emits through the surface area and the ventilation. In the hourly average temperature of January, the difference during 4 days reached 24 °C, which has to be compensated by the heating performance,

which is made even harder by how weather is sunny (with high radiation), or foggy-cloudy, when there is a weaker, more spread radiation. These extremities cause the system to require bivalent heating, if the well(s)' heating performance is inadequate (f. e. gas heating). Quick changes can be reacted to easily by spare heat containers, but well-side errors may also offer them some use. In case the well produces excess, the container is filled, and in case there is excess energy, the heat container offers extra heating. I analysed three specific time periods (Figure 15), and determined that extreme weather conditions and havoria cold can both be averted for 6-8 hours when using a buffer.

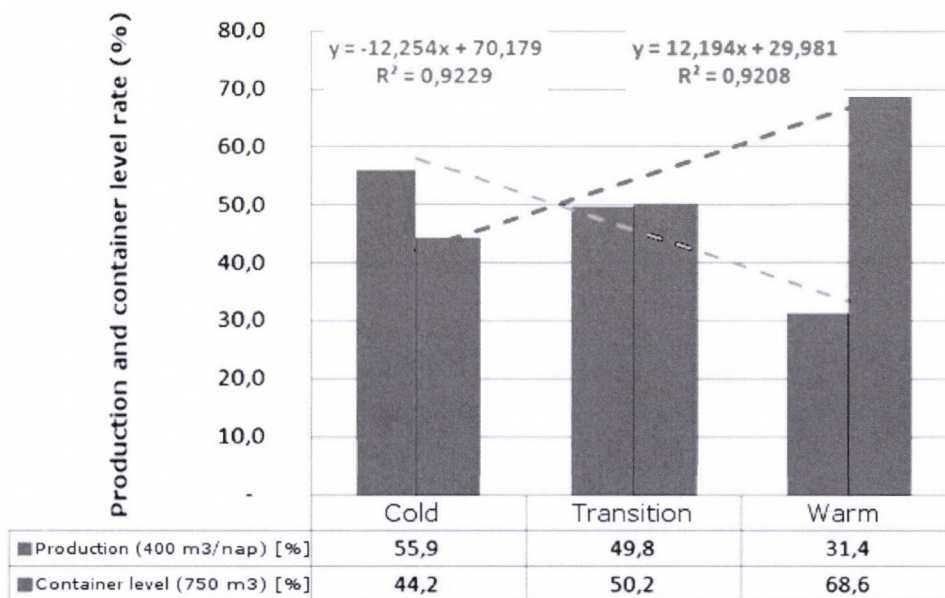

Figure 15. Conditions of the container's level and continuous water supply (production) ratio, in more general environmental temperature timeframes.

4. Conclusions

The detailed analysis of the 20 wells in the area around Szegvár and Szentés, and the results of the in situ measurements made me conclude that the resting water level compared to ground level has decreased by 25-30 mm

in the last 40 years. We proved that during the wells' rest period, a "fluid layer exchange" happens via cross-filling between water yielding layers. Therefore, the different water yielding layers are connected, which causes the resting wells to also have fluid movement, which also means that the water yielding layers can also act as water

absorbing layers during production. Generally in the resting period, when the period starts, filling goes towards the previously water yielding layer, which causes the flow in the well body to go vertically up or down between the filtered layers.

By analysing the measurement data, we were able to prove that the water level of porous-based thermal wells resting, and situated on the Southern Great Plains is influenced not only by the cross-fillings, but periodically (both daily and monthly) the Moon's low tide phenomenon as well.

We proved that a correct well measurement and comparison can only be done with measurements done within the same Moon cycle.

We proved that for wells maintained on the Southern Great Plains - even though the water level decreased, and production persisted for ~40-45 years – do not have a significant decrease in production. The water yielding layers of the Southern Great Plains' wells show a correlation of different flow and temperature, and depth gradients, and the absorbing layers, which shows they affect each other. I proved that refilling used (lowered enthalpy) water is possible, which means the base requirement is met. However, its success is greatly dependent on the attributes of the stone bed (size of grains, pore tunnel size, migrating material content, etc.). We proved that for planning refilling, only the monitoring well which proves the state of the water yielding and absorbing layers opened and filtered is usable.

We were able to prove that out of all the energy resources used for heating greenhouses (by the current market prices) the geothermal energy produced via convection is the most economically sound option. The three temperature level heating is the most advantageous, due to the different requirements caused by weather conditions, using a buffer container, and increasing the exergy of the "waste heating" remaining in the fluid, and the obtained heat content followed by rerouting it into the system's vegetation phase. Even in the case where the water which had its exergy removed after using the heat pump, and we also increase the specific energy costs with those of the refilling well.

We proved that the costs of establishing a heat pumping system, and the costs of establishing and maintaining a new pair of wells is covered by the excess energy produced (due to advantageous COP and SPF) in 2,5-3 years. Using the enthalpy of the "used water" only has an advantage above a COP value of 6,0 in spite of its economic advantage, due to the electricity production's CO2 emission using natural gas heating (direct gas heating). We proved that using a heat pump can only be better environmentally when using renewable resources, when compared to natural gas heating. The optimal solution - if enough methane is at hand - is to use either separated and dried methane combustion, or mechanical heat pumping.

We proved that installing a buffer container into agricultural greenhouses' heating systems assures the safety of production (in case of significant and fast changes in weather and system errors), reduces the investment and management costs of necessary spare requirements (well capacity at hand) and spare energy resources. Depending on warm and cold weather, the level in containers is

inversely proportional to the fluid production ($R2 = 0,92$). We proved that refilling and the usage of a heat pump and buffer containers are advantageous from both sustainability, environmental protection and agricultural economical benefits' perspective.

References

- [1] **Ádám B.:** 2008. Hőszivattyús földhő hasznosítás aktuális helyzete Magyarországon az EU helyzet tükrében, Kistelek, Geotermia a XXI. században szakmai fórum, 2008.
- [2] **Bobok E., Takács G., Turzó Z.:** 1998. Present status of geothermal energy production in Hungary (A geotermális energiatermelés jelenlegi helyzete Magyarországon), Proceedings of Geothermal Resources Council, San Diego, 1998.
- [3] **Strober I., Bucher K.:** 2013. Geothermal energy: from theoretical models to exploration and development, Springer, London, eBook, pp. 252-254. <http://dx.doi.org/10.1007/978-3-642-13352-7>
- [4] **Nagygal J., Tóth L., Horváth B., Bártfai Z., Szabó I.:** 2015. Enhancing The Effectiveness of Thermal Water Consumption Via Heat Pumping. Applied Studies in Agribusiness and Commerce, Vol. 11 No 4, pp. 53-99. <http://dx.doi.org/10.19041/APSTRACT/2015/4/7>
- [5] **Dincer I., Rosen M. A.:** 2007. Exergy: Energy, Environment and Sustainable Development, Elsevier, Oxford (UK), p. 13.
- [6] **Nagygal J., Tóth L., Horváth B., Fogarassy Cs.:** 2017. Thermal water utilization in the hungarian greenhouse practice. Thermal Science Vol. OnLine-First (00) <https://doi.org/10.2298/TSCI160831011N>
- [7] **Ásbjörnsson E. J.:** 2016. Renewable energy and carbon reduction, Reykjavik University. Slideshow, pp. 2-6.
- [8] **Nagygal J.:** 2014. Experiences of the Geothermal Project in Szentés, in: Hungary IGC, Freiburg, Germany, pp. 1-13.
- [9] **Nagygal J., Tóth L., Beke J., Szabó I.:** 2015. Comparison Of Possible Greenhouse Energy Sources. Hungarian Agricultural Engineering Vol. 26, pp. 47-53. <http://dx.doi.org/10.17676/HAE.2014.26.47>

Notations

T_t	temperature of the container	°C
T_r	temperature of the refilled water	°C
T_0	temperature above ground	°C
\dot{m}	mass flow of the heating water	kg/h
q_0	heat performance procured	J
w	compressor work put in (energy)	kWh
COP	specific cooling (Coefficient Of Performance)	-
ε	specific cooling	-
e	specific exergy	kWh/kg
a	specific aenergy	kWh/kg
\dot{E}	exergy	J
$t_b - t_k = \Delta t$	difference between external and internal temperature	°C
$F_{\dot{u}}$	size of the greenhouse surface area	m ²
Q_{FC}	effective heat energy	J

E_o	energy consumed by the system	J	t_e	external temperature of	
Q_{FC}	effective heat energy	J,		the greenhouse's atmosphere	$^{\circ}C$
E_o	energy consumed by the system	J.	k	Permeability	μm^2
ηE	P/Qfg efficiency of producing used electricity	-	$G_{rad} T$	Temperature gradient	$^{\circ}C/km$
$Q_{\text{össz}}$	total energy of the fluid	J	L_t	Base depth	m
Q_{VSZ}	total energy of the refilled fluid	J	SPF	Seasonal Performance Factor	-
P_{VE}	(electric) energy used to propel the heat pump		<i>Abbreviation</i>		
Q_{EXE}	efficient heat energy (exergy)	kWh	TL	Temperature measurement	-
ko	thermal transmittance coefficient of the greenhouse	J	FLOW	Flow measurement	-
t_i	internal temperature of the greenhouse's atmosphere	$W m^{-2} K^{-1},$	REF	Refilling	-
		$^{\circ}C$	P_{rise}	Pressure increase	-
			P_{grad}	Pressure gradient	-
			H	Water level	-