

EXPERIMENTAL INVESTIGATION OF DROP-IN APPLICATION OF NATURAL REFRIGERANTS

Author(s):

P. Hermanucz¹

Affiliation:

¹ Doctoral School of Mechanical Engineering – Hungarian University of Agriculture and Life Sciences, 2100 Gödöllő, Páter Károly u. 1., Hungary;

Email address:

hermanucz.peter@uni-mate.hu

Abstract: Cooling of raw materials and products in the food industry as well as in the whole food chain, including transportation and storage is an important task because it has a great impact to the product quality. This paper deal with the drop-in application of refrigerants in cooling systems used in the food industry. The focus of my research is to investigate the defrosting cycle of an evaporator in a cooling chamber with respect to the thermal medium used. Since during the process the temperature of the chamber can fluctuate, which can increase the deterioration of the stored food. My hypothesis is that if an environmentally or energetically beneficial change of refrigerant is implemented in a plant, the length of defrosting cycles will also change. My aim is to mathematically describe the relationship between refrigerants, chamber temperature and defrosting time. This will help to predict the effect of a possible refrigerant change on the length of the defrost cycle as a function of the chamber temperature.

Keywords: cooling system, natural refrigerant, drop-in, food storage, R290

1. Introduction

The need for refrigeration arises in different ways in different parts of the food chain: one way is to cool raw materials as quickly as possible, another is to achieve very low temperatures and, of course, to keep the temperature of the food product at a near constant level during transport and distribution. Artificial refrigeration is widely used to solve these problems.

An essential part of the refrigeration cycle is the refrigerant itself, which also poses some risks to global-environmental and human health. In many cases, the refrigeration circuit is in technically satisfactory condition, but replacing it would mean rebuilding or replacing the whole system because of the environmental impact of the refrigerant used. This is the case, for example, with the replacement of CFC or HFC refrigerants (R22, R32), which either have an ozone depleting potential or a global warming potential (GWP) that is too high [1], and where natural refrigerants with a lower GWP are available, such as R290 [2]. The solution to this problem is drop-in replacement, where no modification is required to the equipment, but only the refrigerant is replaced by a less environmentally damaging alternative.

But equally important is the risk posed by the quality of the refrigeration within each element of the cold chain, which has been investigated in several studies [3]. It has been found that the shelf life and deterioration of chilled products can be seriously affected by temperature fluctuations in the chilled compartment, as has been demonstrated by others [4]. Significant temperature fluctuations can be achieved even by opening the door of a simple household refrigerator [5]. Similar research [6] has also shown the effect of chamber temperature fluctuations on stored food products by simulation and measurement. There is a close correlation between the two, since the refrigerant used in the refrigeration circuits essentially determines the cooling capacity that can be achieved with a given piece of equipment [2] and, for equipment operating below 0°C, some characteristics of evaporator defrosting.

In industrial refrigeration system studies, it has been shown that hot gas defrosting, especially when applied with a time offset across multiple evaporators, resulted in a much more uniform internal temperature in the

interior for air-to-air heat pumps compared to off-off defrosting [7]. However, this is only feasible for systems with multiple evaporators connected in parallel. In my case, the cooling chamber has only one evaporator, so this method is not applicable.

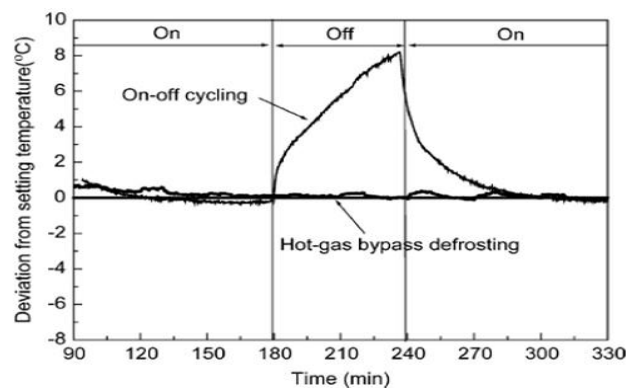

Figure 1. Comparison of on-off and hot gas defrosting [7]

For systems with a single evaporator, the temperature swing due to shut-down or hot gas defrosting is virtually identical to the "on-off cycling" shown in Figure 1, and therefore poses a serious quality risk to food stored in agricultural refrigeration equipment. The understanding of this temperature swing and the effect of refrigerant change on this phenomenon is a very important area of research, especially when considering the beneficial environmental impact of refrigerant change.

Although several evaporator designs are possible, the construction of evaporators used in industrial refrigeration is practically identical to that of simple air-to-air heat pump units. The evaporator's operation and its de-icing capabilities, and in many cases also its construction, are so similar that the evaporator of heat pumps can be used to model evaporators used in refrigeration chambers.

In this paper, I will investigate the de-icing options for evaporators, identify commonly used methods, and then measure the effect of refrigerant change on the length of defrost cycles. Finally, I will construct a simple mathematical model describing the relationship between the two, with parameters specific to the refrigerant.

2. The De-Icing Procedure

The evaporator of refrigerators and cooling chambers is an air-coolant heat exchanger consisting of finned copper tubes, the operation and modelling possibilities of which have been studied previously [8]. The refrigerant evaporates in the tubes, the heat flows through the fins from the air to the inside of the tubes. Consequently, the temperature inside the tubes is always lower than the air flowing through the evaporator. The water vapour in the air will condense on the fins to a certain extent. If the temperature of the fins reaches freezing point, they may become drier or the water that has condensed may freeze. In the case of a serpentine layer, the formation of the frozen layer occurs by the loss of the liquid phase, but in the case of refrigerated chambers, water may first condense on the fins and then freeze into ice of varying structure. I will refer to this phenomenon collectively as ice formation.

At low chamber temperatures, formation is reduced, as the absolute humidity of the air decreases significantly with decreasing air temperature. The advantage of this phenomenon is that it allows isothermal heat removal, which improves the COP of the cooling circuit, but the disadvantage is that the cross-section between the fins decreases, thus reducing the airflow. In addition, the dermal layer acts as an insulator, increasing the temperature difference between the two sides of the heat exchanger, thus reducing the evaporating temperature, and hence the evaporating pressure and ultimately the COP. In extreme cases, it makes the equipment completely inoperable, so it is necessary to guard against this phenomenon. Below are some procedures, perhaps little known, to prevent or remove the formation of a layer of dross.

2.1 Methods for avoiding and removing the ice layer

A method that can be used to avoid the formation of a layer of white frost is the hydrophobic treatment of surfaces. In this case, a hydrophobic paint is applied to the heat transfer surface, to which water droplets bind over a smaller surface area, thus improving the efficiency of the defrosting process. Some researchers have

used a paint with hydrophobic properties, applied to the surface of the heat exchanger plates in a thickness of 30 μm [9]. This method is rather complementary to the others.

It is also possible to prevent ice formation using vibration, which is one of the simplest methods to prevent ice formation (frozen layer formation). Previously, the effect of vibrations has been investigated using an electrodynamic shaker with different amplitudes ($40 \leq D \leq 100$ mm) and frequencies ($100 \leq f \leq 200$ Hz) [10]. The results were encouraging, but in practice it is difficult to imagine an engineering solution where the whole evaporator is vibrated. This solution has also not been widely used in practice.

Ultrasonic ice breaking is also known. In this field, [11] experimented with high-frequency ultrasonic vibration and observed a reduction of the ice layer of about 60% using an ultrasonic source with a frequency of 37 kHz and an amplitude of 3.1 μm . The test was carried out for 90 min at an ambient temperature of 2°C and nearly 100% relative humidity on an aluminium plate. Similar studies [12] investigated the effect of ultrasonic vibration on the ice formation of a fin-tube evaporator subjected to natural convection. These test conditions cover only a small part of the cooling chamber applications.

However, very simple methods for defrosting are available. An example is the de-icing by compressor shutdown, which is analysed in detail in [13]. However, this method can only be used for chambers operating at temperatures above 0°C, which would significantly limit the applicability of the test results, and I have not dealt with this method in detail. Another very simple and widely used method is the electrically heated de-icing method investigated by [14]. In this case, an electric heating coil integrated in the evaporator performs the defrosting while the cooling circuit is not in operation. The disadvantage of this method is that temperature oscillations similar to those mentioned above are generated in the chamber. Furthermore, it is not energy efficient, as direct electric heating is always inferior to using a cooling circuit in heat pump mode.

The most common method, however, is the defrosting process by reversing the cooling cycle, which has been investigated by [15]. This method injects high-temperature refrigerant vapour from the compressor into the evaporator to accelerate the melting process. It is complex and relatively expensive to design, but the efficiency of the defrosting is better than, for example, electric filament defrosting, as the hot gas flows through the entire pipe network and can heat the entire surface of the heat exchanger. In this arrangement, the direction of the hot coolant vapour flow is the opposite of the normal operation and is therefore often referred to as reverse cycle hot gas defrosting, especially in the international literature. As this is the most common process, and the one I am investigating in my work, I will now look at the special features of this type.

2.2 The relation between defrost cycle and the refrigerant

In previous studies, measurements have been made to identify the automated defrost cycle of a cooling circuit. The results are presented in Figure 2.

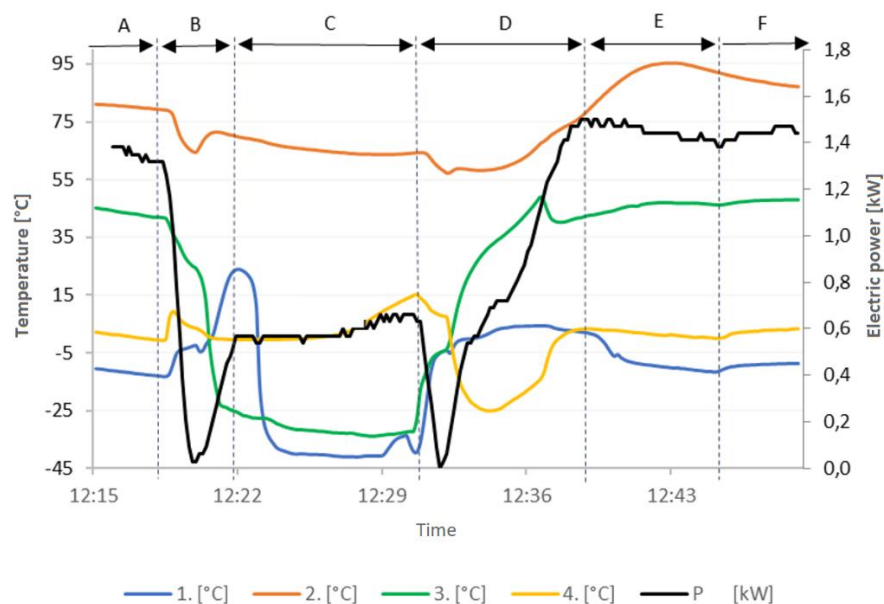

Figure 2. Temperature values measured during a typical defrost cycle

The diagram shows that at the end of stage C, the evaporator heats up to +15°C to achieve perfect defrosting. The same temperature during operation was between 0...-5°C, so a fluctuation of at least 15K can be observed. However, when the system is restarted, the evaporator can briefly cool down to -25°C, which underlines once again the importance of temperature swings and the need to avoid them or increase their periodicity. The names of the periods and the measured characteristics are shown in Tables 1 and 2.

Table 1. Parameters measured and their names in the cooling circuit

Designation	Mesured parameter
1	Compressor suction side temperature [°C]
2	Compressor discharge temperature [°C]
3	Condenser outlet temperature[°C]
4	Evaporator outlet temperature [°C]
PeI	Total electric power consumption of the system [kW]

Table 2. Designation and marking of registered periods

Period	Subrutin	Time range[s]
A	Normal operation in cooling mode	~1500
B	Decrease compressor speed and reversing the cycle	200
C	De-icing in reverse cycle	520
D	Restore the normal coolinc cycle and increase compressor speed	450
E	Warm-up the condenser	400
F	Normal operation in cooling operation	~1500

Figure 3 shows a simplified theoretical connection of the cooling circuit with the measurement points marked and the same points marked in the logp-h diagram.

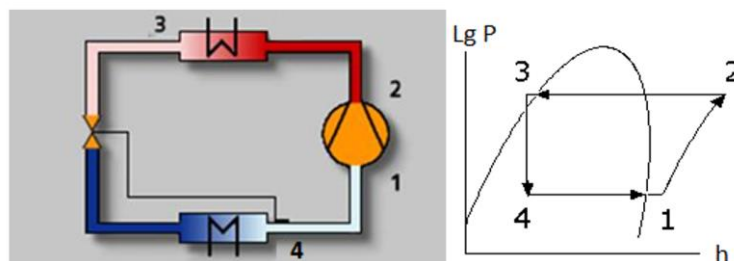

Figure 3. The measured parameters in the cooling circuit and in the logp-h diagram

From the above, it can be seen that the length of the "C" period and the period of the defrost cycle in a refrigerated chamber with an evaporator have a major influence on the temperature oscillations inside the chamber and, through this, on the quality of the stored food. In this paper, I investigate the length of the "C"

period under unchanged settings when using two different refrigerants drop-in compared to the results obtained with the factory reference refrigerant.

3. Materials and Methods

In order to carry out the planned tests, I had to develop a suitable device, the outline of which is shown in Figure 4. The refrigeration circuit investigated had a nominal cooling capacity of 2.5 kW. The evaporator (labelled as ODU in the figure) was placed in a well-insulated chamber. The heat extracted from the chamber was partially covered by the heat flow entering the boundary structures, but a very large part was introduced in the form of latent heat as water vapor produced in the steam generator connected to the chamber. With this procedure, the highest possible humidity in the cooled space is achieved, which at the same time ensures the highest degree of frosting in the case of the tested evaporator.

This was necessary to ensure that the defrosting cycles were carried out as quickly as possible and under reproducible conditions. The experiments were not designed to reproduce the real operating conditions of a cold chamber, but focused on the scientific investigation of the defrosting cycles.

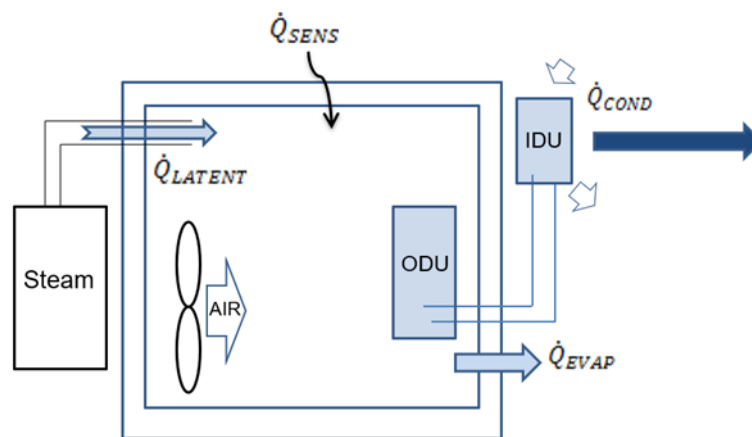

Figure 4. Schematic diagram of the measuring device

The condenser (labelled a IDU in the figure) was installed outside the chamber, so it is allowed to maintain a constant condensing temperature. The indoor temperature can be kept almost constant by changing the switching cycle time of the steam generator and by using air mixing fans. The air distribution in the tight space proved to be very even, the vertical temperature difference was not more than 1 °C. The air tightness of the chamber is adequate, as the 2 holes with 30 mm diameter, through which the electrical and refrigerant lines run, were sealed.

For the application of different refrigerants, I built new refrigerant connection points on the tested equipment, through which it was possible to drain the refrigerant, vacuum the system and drop-in the new refrigerant. With this method I was also able to perform pressure measurements for control purposes, too.

The procedure for changing the refrigerant was the same in all cases. The amount of charge was set so that the amount of material circulating in the system was constant. This meant different amounts by mass due to the different molar masses of the refrigerants. Compared to the reference R32, a larger amount of R410a was needed, while a smaller amount of R290a was needed.

3.1 Measuring devices

To study the defrosting cycles, it was necessary to analyse the transients and determine the time between them. The time was always determined in relation to a change in temperature values (the method for this is described later), so I used a 10s resolution machine recording. For my measurements, I used the so-called IMSy - Intelligent Measuring System, which has the great advantage of transmitting the measured values immediately to a server. The data can also be displayed on-line via the Internet, as shown in Figure 6. It is also possible to export the data retrospectively in .csv format for further processing. I used on-line display for the duration of the measurement, so that I could observe the unfolding of a defrost cycle in real time. The time duration of each stage was later determined using an excel spreadsheet.

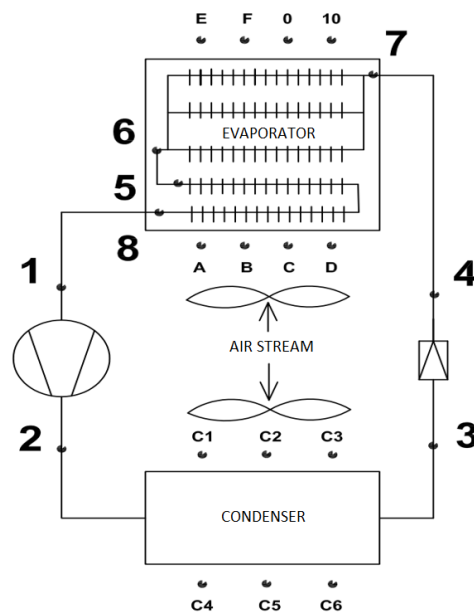

Figure 5. The measurement system and measurement locations

At each of the 24 measurement locations shown in Figure 5, measurements were taken with a Dallas DS18B20 digital thermometer with an accuracy of 0.5°C over the range -55...+125°C. The electrical power was measured using a TV0F11 device, while the relative humidity was measured using a DHT11 digital meter. The temperature sensors were fixed to the copper tubes inside the apparatus, secured with self-adhesive aluminium tape for proper heat conduction and shielded from external influences with closed-cell pipe insulation.

3.2 The investigated refrigerants

During my measurements, I used several refrigerants in the case of my defrost cycle test rig. These were R32, R290 and R410a, so I will briefly describe the properties of the refrigerants I used.

3.3 Refrigerant R410a

A blend of R32 and R125 (50/50 wt%), which is a near azeotropic blend, therefore has an extremely low temperature slip, and is almost non-fractionable during evaporation. Thus, there are less problems with leakage and no fear of the medium pair breaking up. It has an ODP of 0, a high GWP of 2088 and is therefore already being phased out of the market, which makes it interesting to investigate its substitutability. This blend is about 60% more pressurised than the cooling circuits designed for R290 and can only be used in new equipment designed for increased pressure. The use of R410a requires the use of POE (poly-olefin ester) lubricants.



3.4 Refrigerant R290

Today, hydrocarbon-based refrigerants are enjoying a renaissance because their ODP is 0 and their GWP is negligible. They were already used in refrigeration before the discovery and diffusion of Freon refrigerants, so they are not revolutionary, but their use does present a number of unprecedented challenges for both professionals and manufacturers. As hydrocarbons, they have a high flammability, which was not the case with the so-called safety refrigerants used until now. This property is problematic not only for installation but also for production, servicing and decommissioning, since these "gases", although marketed as a gas for combustion (R290 = pure propane), are not odorous in the air conditioning version, which makes it difficult to detect leaks by sensory means.

3.5 Refrigerant R32

It is the most recently used refrigerant, despite having been known for decades as a component of R410a. Its flammability and high pressure have long discouraged its use on its own, but its uptake has accelerated as climate protection goals have come to the fore. However, its combustion properties are much more favourable than those of hydrocarbon refrigerants, it is practically non-toxic, its ODP is of course 0 and its GWP is 675, which allows its wide use. The main physical properties of the refrigerants I have used are shown in Table 3.

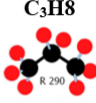
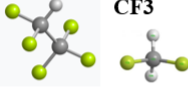
Table 3. Physical properties of refrigerants used

Refrigerant	R290	R410A	R32
Composition	Propane 99.5% (Isobutane, n-butane)	Pentafluoro-ethane (R-125) 50% Difluoromethane (R32) 50%	100% Difluoromethane (R32)
Formula	C_3H_8 	CH_2F_2, CHF_3 	 CH_2F_2
Molecular weight	44.0 (g/mol)	72.6 (g/mol)	52.024 (g/mol)
Smell	Slight odor	Faint ethereal odor	Odorless
Freezing point	-185.89°C	Not determined	-136°C
Boiling temp. at 1.013 bar	-42.1°C	-51.58°C	-51.7°C
Critical temperature	96.67°C	72.13°C	78.35°C
Critical Pressure	42.50 Bar	49.26 Bar	58.16 Bar
LFL	2.2%	None	13.3%
HFL	9.5%		29.3%
Auto-ignition temp.	480°C	>750°C	530°C
ODP	0	0	0

3.6 Settings and determination of defrost cycle times

With the help of the measuring system, the outside temperature can be set within very wide limits, however, I always kept the relative humidity at the maximum value. The setting value that best suited the purpose of my studies was determined during preliminary experiments. As a result, I decided to examine the chamber temperature between -10...+10°C in detail, and this will also be shown in the figures. My decision was based on the fact that at this temperature the air can still hold significant humidity, but it is sure to freeze on the surface of the heat exchanger. Of course, I performed several measurements in the range of -10...+2°C, but I only evaluated the length of the defrost cycles. Preliminary measurements show that this does not necessarily occur above +2°C or only for a very long time, despite the fact that the evaporation temperature of the medium is slightly below freezing.

The settings were the same for all three refrigerants I tested, R410a, R32, and R290. The effect of the three refrigerants on the defrost cycles was investigated primarily, so I did not evaluate them from an energy point of view. The energy evaluation was performed only for the factory R32 gas charge.

In order to perform this task, it is absolutely necessary to know the time course of the temperatures reached at the characteristic points of the cooling circuit, as well as the intake and exhaust air temperatures play an important role. Correct, comparable measurements can only be made under laboratory conditions, where numerous interfering effects can be eliminated.

In the study of defrost cycles, the evaluation of transients was very important because I had to determine the beginning and end of the defrost cycle during these short periods. Given that the exact definition of the defrost cycle is not known, I will briefly describe the procedure I have used: I consider the defrost cycle to be the period during which the heat flow of the condenser is not positive. Based on this logic, I evaluated the data series in the excel spreadsheets and plotted the melting times in a graph using the method of least squares sum of deviations to judge the fit of the characteristic curves.

3.7 Mathematical background for data evaluation

I present the evaluation of the measurement data with the help of diagrams. I fitted a trend line to the data series, I gave the degree of fit (R²) and the root of the mean square error (RMSE) in the relevant cases, and I was able to draw useful conclusions from them. I used the formula presented below:

$$RMSE = \sqrt{\frac{\sum_{i=1}^n (\hat{y}_i - y_i)^2}{n}}, \quad (1)$$

where

- \hat{y}_i – the value determined by the function,
- y_i – the value determined by the measurement,
- n – the number of the observations.

The RMSE value shows how much the measurement results “scatter” around the fitted curve, expressed in the same dimension as the measured characteristic.

4. Results

Before the series of measurements were carried out, a test run of the measuring system was performed. According to my preliminary measurements, I cooled the chamber to -26°C without heating, which is limited by the factory protection of the cooling system. At this operating condition, the sensible heat input (Q_{sens}) entering the chamber through the walls was calculated. I calculated it to be only 19.6W/K, based on the difference in air temperature between the chamber and the laboratory. In the calculation, I assumed that the thermal power dissipated by the condenser was the combined power of the evaporator and the compressor. Since I measured the latter two, I can calculate the power absorbed by the evaporator, which is practically equal to the sensible heat flux entering the chamber. This means that for the settings I used, the maximum sensible heat flux entering the walls was 530W, which did not significantly affect the humidification efficiency. In the case I tested, the sensible heat flux entering the dampening system did not exceed 20% of the total heat flux extracted, so it did not significantly affect the measurement.

The test measurements were carried out in the chamber temperature range -26...+15°C. On this basis, I found that the best range for determining the length of defrost cycles was -10...+2°C.

I also verified the proper functioning of the data logging system and found from the recorded data that as soon as the evaporator temperature deviates significantly from the inlet air temperature, the equipment starts the defrost cycle. The cycles follow at regular intervals and, in addition to the temperature measured at 24 locations, the relative humidity inside and outside the chamber can be displayed. This means that the length of the cycles is always determined by the same algorithm set by the manufacturer. Accordingly, measurements with different refrigerants can be compared. I have documented the location and identification of the sensors, which are shown with a textual explanation in the evaluation, while the diagram shows their unique identification. Data for a typical defrost period are shown in Figure 6.

I controlled the temperature of the test chamber with the amount of introduced steam. My goal was to keep the relative humidity of the chamber at a maximum value, which gives the best result in term of the defrost cycles and is reproducible as well. As the temperature of the chamber increases, so does the amount of heat extracted, and thus the amount of steam introduced in a given time. However, this is not a problem for testing the length of the defrost cycles, as I found that the unit always starts defrosting under the same conditions, i.e. when the difference between the refrigerant leaving the evaporator and the chamber temperature increases. This could be found in the Figure 6. Thus, the length of the cycle is not affected by the degree of wetting, only the period time.

Measurements to determine the length of the defrost cycles were performed in the temperature range of -10 and +1°C with at least 4 settings and 3 repetitions per refrigerant. The purpose of the studies was not to show the difference between the refrigerants, but to demonstrate that the trend is generally true regardless of the properties of the refrigerant. At the same time, I consider it's important from an environmental point of view to study the behaviour of R290 refrigerant in the refrigerant circuit, as it has significant environmental advantages over R410a and its COP does not lag behind it in the case of properly sized refrigerant circuits. The test for R32 refrigerant was justified by the fact that many equipment is supplied with this refrigerant today. The results are shown in Figure 7.

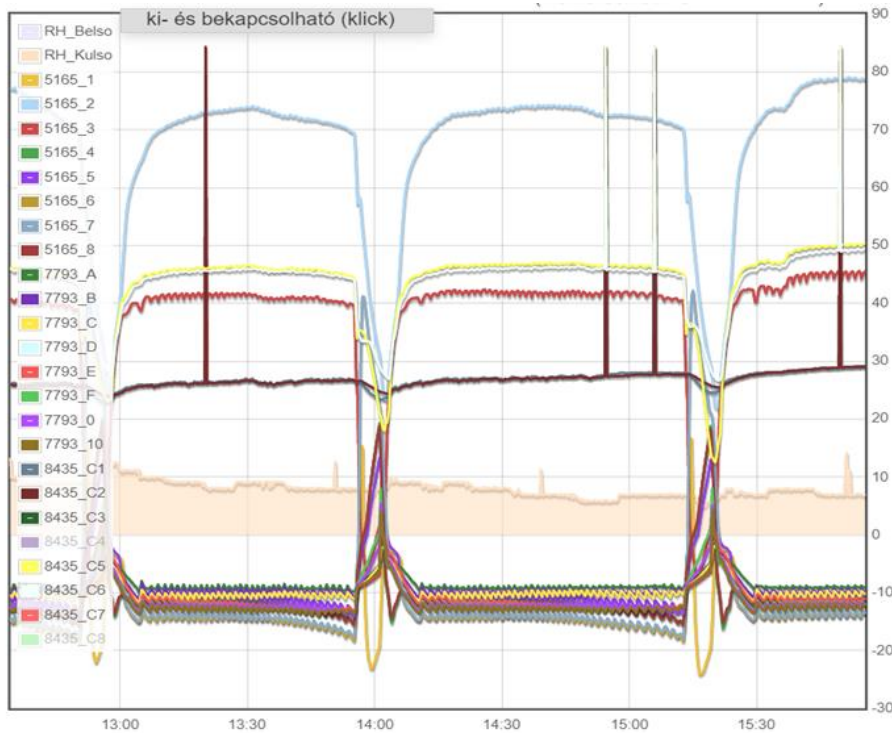

Figure 6. Data stream displayed by the measurement system in real time

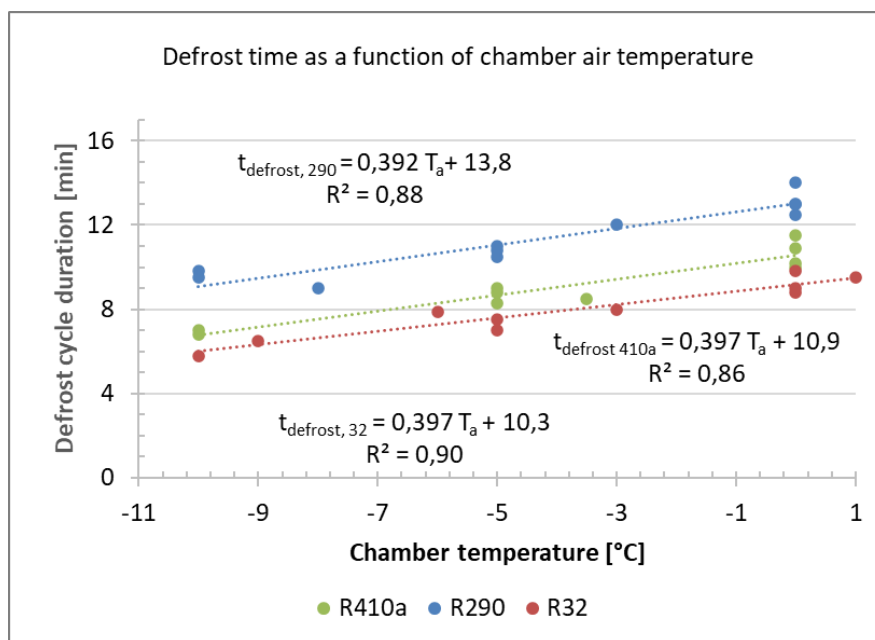

Figure 7. Defrosting time as a function of chamber temperature for three refrigerants

It can be observed that I obtained an increasing defrost time as the chamber temperature increased. This can be explained by the phenomenon that the structure of the frost layer changes at low temperatures, so condensation and freezing of smaller amounts of water already significantly impairs heat transfer. Thus, at lower chamber temperatures, less condensate must be melted, which can be achieved with less energy. In other words, with increasing chamber temperature, more condensate must freeze to reduce the same heat transfer, so more energy is needed in one cycle, resulting in a longer defrost cycle. Given that I did not find any information during the detailed literature review, I consider the above to be a new scientific result.

Defrost cycles are practically non-existent at temperatures above +2°C. Mathematically, this would mean that the plotted curves would drop sharply to 0 here, the physical content of which would be difficult to identify. The explanation for this phenomenon lies in the defrosting strategy of the cooling circuit: defrosting always starts when the temperature of the evaporator outlet line falls below the intake air temperature by a certain value, as shown in Figure 6. As this is an artificial intervention that affects the time elapsed between the defrost cycles, it is possible that a unit jump transition may occur in the behavior of the defrost cycles. This is accompanied by a change in period time. Based on the equations shown in the diagram, I conclude that there is a linear relationship between the defrost cycle time and the outside air temperature, which is

$$t_{defrost} = L \cdot T_a + E \tag{2}$$

describes a general relation, where the constants L and E for the refrigerants I tested are described in the Table 4.

Table 4. The constants I determined for each refrigerant

Refrigerant	L	E	R ²	RMSE
R32	0,397	10,3	0,9	0,97
R290	0,392	13,8	0,86	0,99
R410a	0,397	10,9	0,88	0,55

R2 characterizes the fit of the function, the value of RMSE shows the scatter of the measured values relative to the fitted function. These constants can be used to calculate, among other things, the reduction in operating time caused by defrost cycles.

My suggestion was also confirmed by the examination of the amount of condensate belonging to each cycle, because in the case of each refrigerant I was able to collect an increasing amount of condensate as the chamber temperature increased. I measured the amount of condensate per cycle using a measuring cylinder when using refrigerant R290. The results are shown in Figure 8.

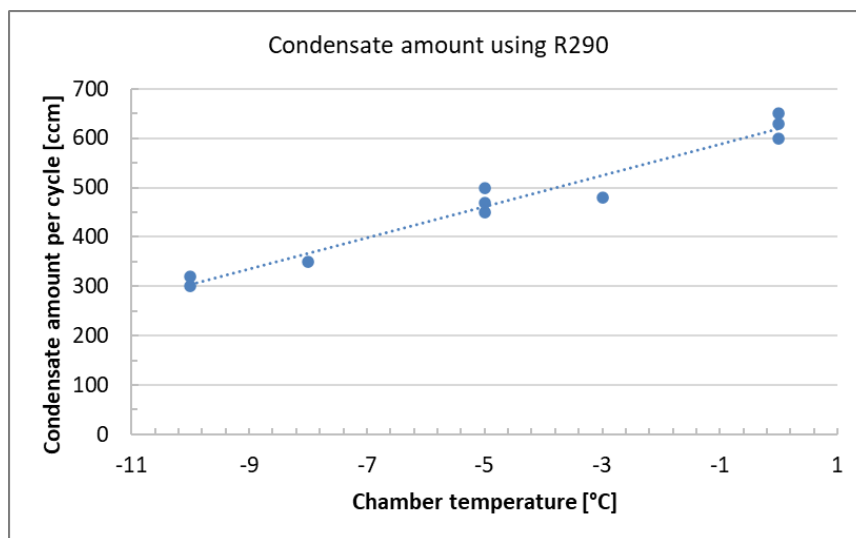

Figure 8. the amount of condensate for R290 operation

The Figure 8 shows that as the chamber temperature increased from -10°C to 0°C , the volume of the condensate increased from 310cm^3 to 630cm^3 . This increase in volume justifies the increase in defrosting time over the same test temperature range.

5. Discussion

The results of my research can be used for food, energy and environmental purposes, among others. For example, the new correlations established from the experiments can be used to describe the defrosting time of the evaporator in a food refrigeration chamber if the refrigerant used in the refrigeration circuit is replaced by another refrigerant using a drop-in process. A possible solution to the problem studied in [7], or a possibility to predict the problem for several refrigerants using the same equipment, has thus been explored.

At first glance, an increasing defrost time with increasing chamber temperature may seem strange. The phenomenon is also one of the less researched topics. In investigating the reasons for this phenomenon, I found that the amount of condensate per defrost cycle increases in proportion to the chamber temperature, i.e. for higher chamber temperatures, the cycle starts at higher condensate amounts with the same defrost logic. This explains the increase in time required for defrosting.

Drop-in replacement of refrigerants can also have significant environmental benefits. Old refrigerants with high GWP can be replaced by modern alternatives with little or negligible environmental impact without any technical intervention on the equipment. An example of such a replacement is the substitution of R410a or R32 (GWP=2088...675) with R290 (GWP=3), which I have investigated.

6. Conclusions

Summarizing the results of the measurements, it can be concluded that drop-in replacement of refrigerants is feasible in the investigated thermal cycle. With R410a and R290 refrigerants used in the same quantity instead of the originally used R32 refrigerant, the refrigeration circuit remained operable without any modifications. No anomalies were observed in the experiments and the energy characteristics of the equipment did not differ significantly from those of the original refrigerant.

The experimental set-up proved to be suitable for measuring the length of defrosting cycles in a reproducible way, as the cycles followed each other with almost the same periodicity when measured at the given settings.

A correlation between the length of defrost cycles, the chamber temperature and the type of refrigerant used was found and mathematically defined. This suggests that there is a clear and inefficient relationship between defrosting time and chamber temperature. Furthermore, a relationship between the vertical offset of the function describing the defrost cycle length and the type of refrigerant can be established. By examining the amount of condensate per defrost cycle when using refrigerant R290, I found that it increases in proportion to the chamber temperature.

Acknowledgement

This work was “Supported by the ÚNKP-21-4-I-MATE/8 New National Excellence Program of the Ministry for Innovation and Technology”.

References

- [1] **Cardoso, B.J., Lamas, F.B., Gaspar, A.R., Ribeiro, J.B.** (2017) Refrigerants used in the Portuguese food industry: Current status. *International journal of refrigeration*, vol. 83 p. 60–74
- [2] **Harby, K.** (2017) Hydrocarbons and their mixtures as alternatives to environmental unfriendly halogenated refrigerants: An updated overview. *Renewable and Sustainable Energy Reviews*, Vol.73 p.1247-1264
- [3] **Korzenszky, P., Adebayo, S.** (2018) Cooling and Storing Energetic Analysis in Food Technology In: Géczi, G., Korzenszky, P. (editor): *Researched Risk Factors of Food Chain Gödöllő, Hungary*, Szent István Egyetemi Kiadó p. 131-134, 4p.

- [4] **Géczi, G., Korzenszky, P., Szakmár, K.** (2017) Cold chain interruption by consumers significantly reduces shelf life of vacuum-packed pork ham slices. *Acta Alimentaria: An International Journal of Food Science* 46: 4 p. 508-516, 9 p.
- [5] **Géczi, G., Dodog, Z., Székely, L., Veres, A.** (2018) Examining the effect of door opening on the operation of domestic fridge In: Géczi, G., Korzenszky, P. (editor) *Researched Risk Factors of Food Chain* Gödöllő, Hungary, Szent István Egyetemi Kiadó p. 127-130, 4 p.
- [6] **Ghabour, R., Kassebi, S., K., Korzenszky, P.** (2021) Simulation and Experiment of Apple Fruits in Domestic Fridge. *Hungarian Agricultural Research: Environmental Management Land Use Biodiversity* 30: 2 p. 11-14, 4p.
- [7] **Cho, H., Kim, Y., Jang, I.** (2005) Performance of a showcase refrigeration system with multievaporator during on-off cycling and hot-gas bypass defrost. *Energy*, 30, p. 1915–1930.
- [8] **Garbai, L., Méhes, Sz.** (2007) System Theory Models of Different Types of Heat Pumps. *IASME / WSEAS International Conference on Energy & Environment*, Portoroz, Slovenia, May 15-17, 2007.
- [9] **Huang, L., Liu, Z., Liu, Y., Gou, Y., Wang, J.** (2009) Experimental study on frost release on fin-and-tube heat exchangers by use of a novel anti-frosting paint. *Experimental Thermal Fluid Science*, 33, p. 1049–1054.
- [10] **Cheng, C-H., Shiu, C-C.** (2003) Oscillation effects on frost formation and liquid droplet solidification on a cold plate in atmospheric air flow. *International Journal of Refrigeration*, 26, p. 69–78.
- [11] **Adachi, K., Saiki, K., Sato, H., Ito, T.** (2003) Ultrasonic frost suppression. *Journal of Applied Physics*, 42, p. 682–685.
- [12] **Wang, D., Tao, T., Xu, G., Luo, A., Kang, S.** (2012) Experimental study on frosting suppression for a finned-tube evaporator using ultrasonic vibration. *Experimental Thermal Fluid Science*, 36, p. 1–11.
- [13] **Ameen, F. R., Coney, J. E. R., Sheppard, C. G. W.** (1993) Experimental study of warm-air defrosting of heat-pump evaporators. *International Journal of Refrigeration*, 16, p. 13-18.
- [14] **Bansal, P., Fothergill, D., Fernandes, R.** (2010) Thermal analysis of the defrost cycle in a domestic freezer. *International Journal of Refrigeration*, 33, p. 589-599.
- [15] **Jiang, Y., Dong, J., Qu, M., Deng, S., Yao, Y.** (2013) A novel defrosting control method based on the degree of refrigerant superheat for air source heat pumps. *International Journal of Refrigeration*, 36, p. 2278–2288.